



# University of HUDDERSFIELD

## University of Huddersfield Repository

Zhang, Hao, Shi, John Z., Gu, Fengshou and Ball, Andrew

Bending vibration of an automotive turbocharger under the influence of rotor imbalance

### Original Citation

Zhang, Hao, Shi, John Z., Gu, Fengshou and Ball, Andrew (2010) Bending vibration of an automotive turbocharger under the influence of rotor imbalance. In: CM 2010 and MFPT 2010 The 7th International Conference on Condition Monitoring and Machinery Failure Prevention Technologies, 22-24 June 2010, Ettington Chase, Stratford-upon-Avon, England. (Unpublished)

This version is available at <http://eprints.hud.ac.uk/id/eprint/8187/>

The University Repository is a digital collection of the research output of the University, available on Open Access. Copyright and Moral Rights for the items on this site are retained by the individual author and/or other copyright owners. Users may access full items free of charge; copies of full text items generally can be reproduced, displayed or performed and given to third parties in any format or medium for personal research or study, educational or not-for-profit purposes without prior permission or charge, provided:

- The authors, title and full bibliographic details is credited in any copy;
- A hyperlink and/or URL is included for the original metadata page; and
- The content is not changed in any way.

For more information, including our policy and submission procedure, please contact the Repository Team at: [E.mailbox@hud.ac.uk](mailto:E.mailbox@hud.ac.uk).

<http://eprints.hud.ac.uk/>

# **Bending vibration of an automotive turbocharger under the influence of rotor imbalance**

Hao Zhang, Zhanqun Shi, Fengshou Gu and Andrew Ball  
School of Computing and Engineering  
The University of Huddersfield  
Queensgate, Huddersfield, HD1 3DH, UK  
Tel: 0044-1484-472842  
E-mail: [Z.Shi@hud.ac.uk](mailto:Z.Shi@hud.ac.uk)

## **Abstract**

As one of the most common faults, rotor imbalance in a turbocharger will give rise to the bending vibration, which may cause damage to and even destroy the bearings and impellers. Therefore, it is necessary to detect rotor imbalance as early as possible. The present paper develops a mathematical model for investigating the rotor dynamic characteristics of a commercial automotive turbocharger supported on floating ring bearings. In order to reveal the behaviours of oil film instabilities the model takes into account nonlinear hydrodynamic oil film forces instead of linearization. A two-dimensional elastic collision model is introduced to deal with the rub-impact process between such solid parts as journal, floating ring and the bearing. In addition, the change of clearances in floating ring bearing due to temperature increases are also estimated by ignoring the variation of lubricating oil viscosity. Following model development, a numerical simulation is implemented to study the bending vibration of the turbocharger and floating ring bearing under the influence of rotor imbalance. This study paves a foundation for the monitoring of turbochargers.

**Keywords:** Rotor imbalance Turbocharger Nonlinear

## **1. Introduction**

Turbocharger is a forced induction system which helps in intake of more air for combustion. The compressed air allows the engine to squeeze more volume of air for increased fuel-air mixture ratio. Due to the significant improvement of energy efficiency, they are more and more widely used in industry nowadays. However such extreme working conditions as high temperature, high rotational speed, oil adhesion, etc that might give rise to rotor imbalance which would affect seriously the service life of turbochargers. Unfortunately the relatively poor techniques of fault detection make it difficult to detect and eliminate those faults in early stage. The most common approach is to replace the faulty product once accidents happen. Therefore it would be quite meaningful if a modern way were developed to detect and even prognoses faults in advance. In order to implement this aim, the model-based idea is introduced in this paper. It can be imagined that an accurately theoretical model will help us greatly by means of monitoring the real-time signals collected according to the predicted results from the model.

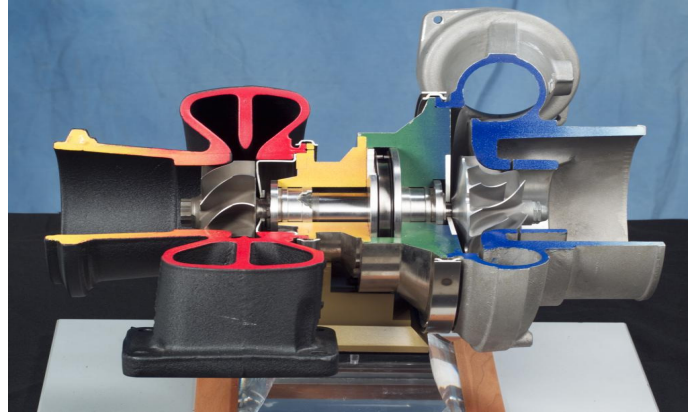

**Figure 1. The structure of an automotive turbocharger**

The structure of a turbocharger is shown in figure 1. It mainly includes impellers linked by a shared shaft, floating ring bearings and a casing equipped outside for protection and also forming the gas path. It can be seen that in rotordynamics turbocharger itself is a rotor model supported on floating ring bearings driven by exhaust gas. As far as rotor-bearing modelling is concerned, it is a fairly popular field attracting a great number of researchers to pay their attentions to, that covers from the simplified Jeffcott rotor model to the complicated model with multi-disks and multi-supports. Finite element method is always a competitive approach in simulating rotor system bending vibration, critical frequencies and vibration modes by discretizing consecutive rotor into a number of mass nodes linked by elastic shaft segments. After forming mass, stiffness and damping matrices, bending vibration could be predicted from rotor system motion differential equations. It should be emphasized that bearing is the key factor during modelling which is also the most complicated part. It is obviously not advised to consider bearings to be the rigid supports with infinite large stiffness coefficients in most cases. The mass-spring-damping model is usually used to describe journal bearings by means of expressing oil film forces in terms of such hydrodynamic coefficients as stiffness and damping coefficients. This linear model is more widely used in response analysis of rotor bearing system. It should be added that the accuracy of such coefficients estimation depends on the estimation of the equilibrium position of a journal bearing to a certain degree. Zheng<sup>(1)</sup> and Klit<sup>(2)</sup> introduced the variational inequality approach to calculate the equilibrium position of the journal as well as the dynamic coefficients. Shuai<sup>(3)</sup> solves the three lobe's journal centre orbit through finite difference method and coordinate alternation method. Compared to ordinary journal bearings, floating ring bearings comprise two oil films that could be modelled by two sets of mass-spring-damping in series in linearized analysis. L San Andres<sup>(4)</sup> developed a model for prediction of floating ring bearing forced response. It is pointed out that the clearances between the solid parts of bearing are affected by the thermal effects and thus influence the rotational speed of the floating ring and the oil film pressure distribution. Kerth<sup>(5)</sup> then elaborated the approach of how to calculate dynamic coefficients of floating ring bearings and predict the rotordynamic response of an automotive turbocharger supported on floating ring bearings.

Although the conventional linear rotor model with stiffness and damping coefficients of bearings could provide a good model for rotor analysis, it has been realised that its predicted results do not match experimental data in some cases especially in sub-

synchronous vibration analysis. Consequently an increasingly number of researchers focus on the nonlinear model development in order to satisfy the accuracy requirement of model simulation. However the mathematics complexity and calculation time restrict researchers to go further in this field and thus the perfect expression of hydrodynamic force is still unknown so far. Zheng<sup>(6)</sup> and Shen<sup>(7)</sup> try to introduce the theory of variational inequality to deal with the oil film pressure distribution and nonlinear hydrodynamic force and a semi-analytical expression has been obtained including unknown parameters which are needed to be estimated by optimization method. Owing to its complexity itself and uncertainty of accuracy, most of published paper still adopt the theory of infinite long or short bearings. Cheng<sup>(8)</sup> investigate the nonlinear dynamic behaviours of a rotor-bearing-seal system and obtain the orbit of rotor centre. Helio Fiori de Castro<sup>(9)</sup> use infinite short bearing theory to investigate the whirl and whip instabilities for both vertical and horizontal rotors.

Based on the achievement of rotor-bearing modelling to date, a comprehensive nonlinear model in rotordynamics has been developed for automotive turbochargers. The consecutive rotor system is discretized to a finite element model with six mass nodes linked by elastic shaft segments. After forming mass, stiffness and damping matrices, the multi-degree system motion differential equation is established to calculate bending vibration of the rotor system. Apart from its own gravity of the rotor, such major stimulating forces as centrifugal forces caused by rotor imbalance and nonlinear hydrodynamic forces have been studied respectively. In the meantime, influences of rub impact to floating ring bearings have been considered. In order to obtain more accurate results numerical approach is introduced here to deal with the nonlinear hydrodynamic forces and system bending vibration simulation. Following model development, bending vibration of turbocharger rotor system have been predicted under the influences of rotor imbalance imposed on the impellers.

## 2. Modelling for the turbocharger in rotordynamics

### 2.1 Finite element model

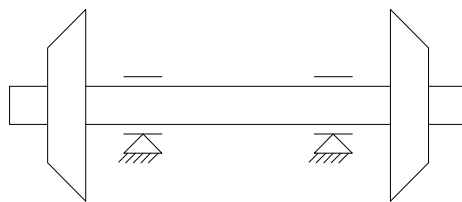

Figure 2(a). Physical model of turbocharger core



Figure 2(b). Finite element model of turbocharger core

Turbocharger core consists two impellers linked by a shared shaft supported by two floating ring bearings. The physical model is shown in figure 2(a) and the finite element model is illustrated in figure 2(b). The model includes six mass nodes and five elastic shaft segments. Since mass and moment of inertia of the shaft segment have been assumed to concentrate on both two sides, system mass and stiffness matrices become diagonal. Stiffness and damping matrices are determined through the elastic shaft segment element analysis. Main resources that might stimulate bending vibration to an automotive turbocharger include rotor imbalance on the impellers, hydrodynamic forces and its own gravity<sup>(11)</sup>. According to the theory of finite element method, the system motion differential equation is given as follows.

$$[M]\{\ddot{U}\} + [C]\{\dot{U}\} + [K]\{U\} = \{F_{imbalance}\} + \{F_{inner}\} + \{W\} \quad (1)$$

where  $\{U\} = \{x_1, \dots, x_6, y_1, \dots, y_6\}$  represent displacements of the nodes on horizontal and vertical planes.  $[M], [C], [K]$  represent mass, damping and stiffness matrices respectively. On the right hand side of the equation, forces vectors mainly include imbalance centrifugal forces  $\{F_{imbalance}\}$ , hydrodynamic forces in inner oil film  $\{F_{inner}\}$  and the gravity  $\{W\}$ .

Motion of the floating ring is determined by such force vectors as outer and inner oil film forces and its own gravity. The differential motion equation of floating ring is given by equation (2).

$$m_R \ddot{u}_R = \{F_{outer}\} - \{F_{inner}\} - m_R g \quad (2)$$

where  $u_R$  represents the displacement vector of the floating ring,  $m_R$  represents its mass. Force vectors include hydrodynamic forces of two oil films and the gravity. Among three stimulating forces, the values of own gravity keep constant, while imbalance centrifugal forces and nonlinear hydrodynamic forces will be discussed respectively as follow.

## 2.2 Rotor imbalance

Although turbochargers have been generally balanced before being used, rotor imbalance will still be emerged after a period application due to oil/dust particle adhesion, erosion of the impellers and the like. In this case the amounts of imbalance would be unknown. Hence in order to monitor the real-time imbalance, the relationship between certain status parameters and this fault is needed to be established. It has been realised that force response of turbocharger system is dominated by a number of frequencies according to lots of relevant experimental data<sup>(10)</sup>. The vibration component with the same frequency as the rotational speed is synchronous vibration which is caused by rotor imbalance, while other components are sub-synchronous vibration mainly owing to the whirl and whip of the oil films. Therefore it would be possible to detect the imbalance by extracting the synchronous component from the vibration signal.

The finite element model of turbocharger core with rotor imbalance is illustrated in figure 3. According to the theory of rotor balancing, imbalance could be thought to be

distributed on two correction planes at a certain speed<sup>(11)</sup>. Since two impellers are where imbalance moment is more likely to be emerged, it is reasonable to assume to exert imbalance  $U_2$  and  $U_5$  on the second and fifth mass nodes. Generally speaking bearing reaction forces could be collected through force transducers equipped on the bearings in industry. In this case the relationship between imbalance and bearing forces could be established through the working principle of balancing machine, i.e. on a certain plane without other forces, centrifugal forces and bearing reaction forces should follow the rule of force balance and force moment balance<sup>(12)</sup>. However relationship between rotor imbalance and other parameters is needed to be established once the bearing forces are difficult to obtain.



**Figure 3. Finite element model of turbocharger rotor with imbalance on impellers**

Following synchronous vibration component extraction, it can be considered that the influences of bearings have already been eliminated. Turbocharger core, supported on rigid bearings, suffers rotor imbalance centrifugal forces only. While ignoring displacements of the bearings, system motion differential equation has been reduced as follows.

$$[M'] \begin{Bmatrix} \ddot{x}_1 \\ \ddot{x}_2 \\ \ddot{x}_5 \\ \ddot{x}_6 \\ \ddot{y}_1 \\ \ddot{y}_2 \\ \ddot{y}_5 \\ \ddot{y}_6 \end{Bmatrix} + [C'] \begin{Bmatrix} \dot{x}_1 \\ \dot{x}_2 \\ \dot{x}_5 \\ \dot{x}_6 \\ \dot{y}_1 \\ \dot{y}_2 \\ \dot{y}_5 \\ \dot{y}_6 \end{Bmatrix} + [K'] \begin{Bmatrix} x_1 \\ x_2 \\ x_5 \\ x_6 \\ y_1 \\ y_2 \\ y_5 \\ y_6 \end{Bmatrix} = \begin{Bmatrix} 0 \\ A \cos(\omega t + D_2) \\ B \cos(\omega t + D_5) \\ 0 \\ 0 \\ A \sin(\omega t + D_2) \\ B \sin(\omega t + D_5) \\ 0 \end{Bmatrix} \quad (3)$$

where  $A, D_2$  are the amplitude and phase of imbalance centrifugal force on the second node,  $B, D_5$  are the amplitude and phase of imbalance centrifugal force on the fifth node,  $\omega$  is the angular velocity of the rotor.  $[M'], [C'], [K']$  are reduced mass, gyroscopic and stiffness matrices.

According to the theory of rotordynamics, trajectory of every node is supposed to be circles. In the meantime the existence of damping influence gives rise to phase difference between the nodes. Hence the displacements of each node on horizontal and vertical plane are expressed as follows.

$$\begin{cases} x_i = P_i \cos(\omega t + \varphi_i) \\ y_i = P_i \sin(\omega t + \varphi_i) \end{cases} \quad (4)$$

It can be seen that such four unknown parameters are existed on the right hand side of the equation (3). If any four among eight displacements are known, the reduced motion differential equation is able to be solved. In other word the imbalance distributed on two impellers could be estimated if only bending vibrations of any two nodes have been collected.

### 2.3 Nonlinear hydrodynamic fluid forces

Most commercial automotive turbochargers incorporate floating ring bearing to support the rotor because ordinary journal bearings could not bear the extreme high angular velocity (up to 150,000rpm). As shown in figure 4 floating ring bearing comprise two oil films in series, i.e. inner oil film between journal and floating ring, outer oil film between floating ring and bearing. The lubricating oil is fed into outer oil film through an axial groove from centre to near to the edge of the bearing. As the radial gradient of oil film pressure has been ignored, it can be considered that lubricating oil supply pressure of two oil films are approximately the same. Hence apart from the middle of the bearing, oil film pressures of both outer and inner oil film could be estimated by solving Reynolds equation in the oil film land.

$$\frac{\partial}{\partial \Psi} \left( \frac{h}{12\mu} \frac{\partial P}{\partial \Psi} \right) + \frac{\partial}{\partial z} \left( \frac{h}{12\mu} \frac{\partial P}{\partial z} \right) = \frac{V}{2} \frac{\partial h}{\partial \Psi} + \frac{\partial h}{\partial t} \quad (5)$$

For outer oil film,  $h$  represents the gap between floating ring and bearing,  $V$  is the linear velocity of floating ring,  $\Psi$  and  $z$  are the circumferencial and axial coordinate of outer oil film; for inner oil film,  $h$  represents the gap of journal and floating ring,  $V$  is relative linear velocity of floating ring and journal,  $\Psi$  and  $z$  are the circumferencial and axial coordinate of inner oil film respectively.

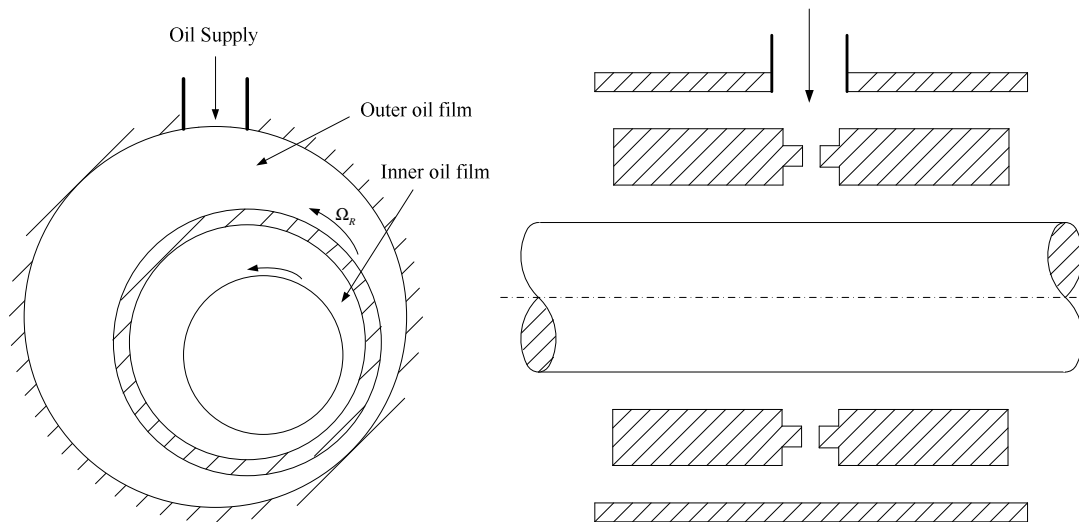

**Figure 4. Floating ring bearing**

Reynolds equation is a second order partial differential equation which analytical solution is still difficult to be obtained so far. Hence such numerical approaches as

Finite difference method and Finite element method are generally suited to deal with it. In the present paper Finite difference method is adopted to solve Reynolds equation in both outer and inner oil fluid films.

It is added that integration interval—the choice of oil film land—affects the equation solution greatly. There are three boundary conditions that are mainly used in oil film pressure distribution estimation, Sommerfeld boundary condition, Semi-Sommerfeld boundary condition and Reynolds boundary condition<sup>(13)</sup>. For Sommerfeld boundary condition, the whole oil film land is considered as full of lubricating oil without cavitation phenomenon. Both positive and negative pressure area are thought to be effective while calculating hydrodynamic forces. Obviously solution results from Sommerfeld boundary condition is a simplified model which rarely satisfy reality. For Semi-Sommerfeld boundary condition negative pressure area is neglected which means only positive pressure area is concerned while calculating hydrodynamic forces. It is true that results based on Semi-Sommerfeld boundary condition are much closer to the reality than Sommerfeld boundary condition. However the problem is that it violates the rule of flow continuity<sup>(13)</sup>. Compared to Sommerfeld and Semi-Sommerfeld boundary condition, Reynolds equation is more reasonable and frequently used in estimating oil film pressure distribution. According to the theory of Reynolds boundary condition, oil film land should exceed the position where minimal clearances between solid parts of bearings are situated until both pressure and pressure derivatives are equal to zero simultaneously.

In this paper Reynolds boundary condition has been introduced in the algorithm of pressure estimation. Following oil film pressure distribution estimation hydrodynamic oil film forces could be calculated by integrating numerically oil film pressure over the oil film land estimated.

#### 2.4 Rub impact

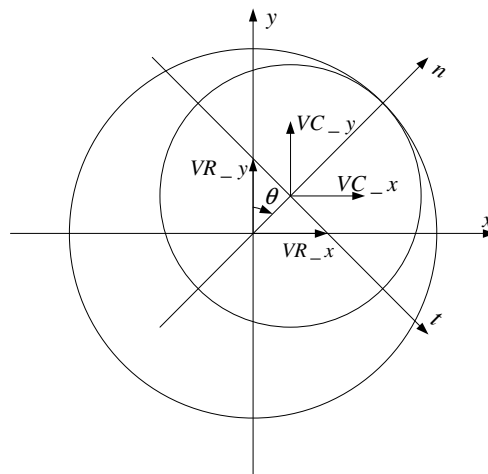

**Figure 5. Physics model of the two dimensional completely elastic collision**

Once rotor imbalance exceeds the permissible value that centrifugal forces would be too large to be overcome by hydrodynamic oil film forces, rub impact of the turbocharger core and floating ring bearing might happen. This process is very complex involving many influences, a simplified dynamic model for it is derived for extruding the main problems.



Since the bending stiffness of the materials of bearings is fairly high and rub impact happens instantaneously in general, a two dimensional completely elastic collision physics model is able to describe this collision process. This model is based on the theory that tangential velocities will be keeping constant during collision period whilst normal velocities obey the rules of momentum conservation theory and kinetic energy theory simultaneously.

The scheme of the two dimensional completely elastic collision between a ring and a cylinder is illustrated in figure 5.  $VC_x, VC_y$  are velocities of the cylinder and  $VR_x, VR_y$  are velocities of the ring.  $\theta$  stands for the angle from y axis to n axis.

According to figure 5, the tangential velocities and normal velocities of the cylinder as well as ring are expressed as follows:

$$\begin{cases} VC_n \\ VC_t \end{cases} = \begin{bmatrix} \sin \theta & \cos \theta \\ \cos \theta & -\sin \theta \end{bmatrix} \begin{cases} VC_x \\ VC_y \end{cases} \quad (6)$$

$$\begin{cases} VR_n \\ VR_t \end{cases} = \begin{bmatrix} \sin \theta & \cos \theta \\ \cos \theta & -\sin \theta \end{bmatrix} \begin{cases} VR_x \\ VR_y \end{cases} \quad (7)$$

The normal velocities during collision follow momentum conservation theory and kinetic energy theory.

$$\begin{cases} m_c VC_n + m_R VR_n = m_c VC_n' + m_R VR_n' \\ \frac{1}{2} m_c VC_n^2 + \frac{1}{2} m_R VR_n^2 = \frac{1}{2} m_c VC_n'^2 + \frac{1}{2} m_R VR_n'^2 \end{cases} \quad (8)$$

where  $VC_n', VR_n'$  represent the instantaneous normal velocities of the cylinder and ring after collision,  $m_c, m_R$  are mass of the cylinder and ring respectively. Following coordinate transformation, the new velocities on the x and y directions could be obtained.

The model of the collision could be divided to such three circumstances to discuss. While collision happening between journal and floating ring without the influence of bearing, new velocities of journal and floating ring could be estimated according to two dimensional completely elastic collision model mentioned above. While collision happening between bearing and floating ring, as bearing here is assumed to be fixed, normal velocities of the floating ring will be reversed after collision while tangential velocities keep constant. As for the contemporary collision between journal, floating ring and bearing, the analysis of this process could be viewed as two stages. The first stage is that journal and floating ring reach the common normal speed and then in the second stage both of them collide with the fixed bearing. The first common normal speed could be calculated by momentum conservation theory. Normal velocities of the floating ring as well as the journal will be reserved after colliding with the bearing.

## 2.5 Solution of differential equations

Bending vibration of a turbocharger could be estimated by solving rotor system motion differential equation (1) and floating ring equation (2). Equations solution is fairly complicated, however, because of nonlinear characteristics of hydrodynamic fluid

forces. Infinite short or long bearings theories could make solution much easier, but obviously the simulation results would deviate from reality inevitably. In this paper Newmark integration method is introduced, therefore, to deal with it due to its robust algorithm and unconditional stability. Although the accuracy of it appears to be lower compared to Runge-kutta method, it could save computing time to a large degree that is more suited to the multi-degree freedom vibration simulation.

It should be added that conventional Newmark integration method is developed for linear system. To extend it to nonlinear dynamic analysis, it requires that iteration must be performed at each time in order to satisfy equilibrium. Also, the incremental stiffness matrix must be formed and triangularized at each iteration or at selective points in time.

### 3. Predicted bending vibration of an automotive turbocharger

The mathematical model is implemented in MATLAB and the relevant parameters have been chosen based on J90 automotive turbocharger. Lubricating oil is fed into the floating ring bearing through the oil supply holes with supplying pressure  $1.38 \times 10^5 Pa$ . Apart from pressure inside bearing, pressure distribution at the other places inside turbocharger casing is assumed to be  $1.01 \times 10^5 Pa$ . Table 1 lists the parameters of the automotive turbocharger and lubricating oil for simulation<sup>(14)</sup>.

**Table 1. Parameters of the turbocharger and lubricating oil in simulation**

Outer clearance of bearing	$8 \times 10^{-5} m$
Inner clearance of bearing	$2 \times 10^{-5} m$
Outer radius of floating ring	$11 \times 10^{-3} m$
Inner radius of floating ring	$7 \times 10^{-3} m$
Length of bearing	$11 \times 10^{-3} m$
Viscosity of lubricating oil	$8cP$
Density of lubricating oil	$0.78 \times 10^3 kg / m^3$
Thermal conductivity of lubricating oil	$0.15W / m \cdot ^\circ C$
Ambient oil pressure	$1.01 \times 10^5 Pa$
Supply oil pressure	$1.38 \times 10^5 Pa$
Mass of turbocharger core	$2.5kg$
Mass of floating ring	$0.1kg$

Supposing turbocharger rotating at  $2000 rad/s$  and imbalance moment  $1 \times 10^{-6} kg \cdot m$  imposed on the turbine impeller, rotational speed of the floating ring could be estimated at about  $830 rad/s$  considering the thermal effects to the oil fluid clearances<sup>(4)</sup>. Bending vibrations of all nodes as well as floating ring have also been predicted. Figure 6 and 7 display the vibration of journal node and floating ring in the steady state respectively.

These results are derived based on the 'zero' boundary conditions which mean that either journal or floating ring vibrates from the origin of the coordinate system at the beginning. The boundary conditions are not reasonable, of course, which cause vibration curves not stable until 0.5s in the simulation and after that, results converge to a stable vibration curve gradually.

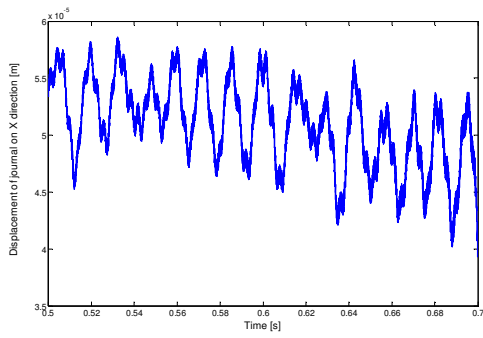

(a)

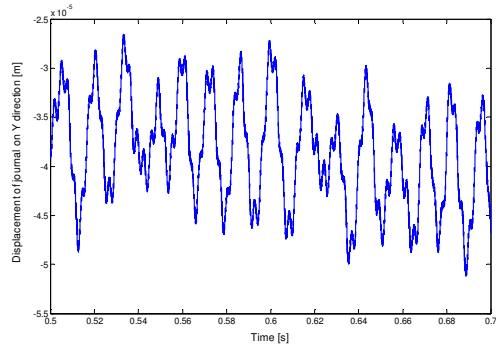

(b)

**Figure 6. Bending vibration of journal: (a) on X direction (b) on Y direction**

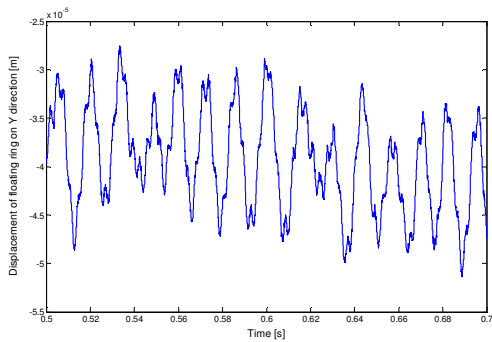

(a)

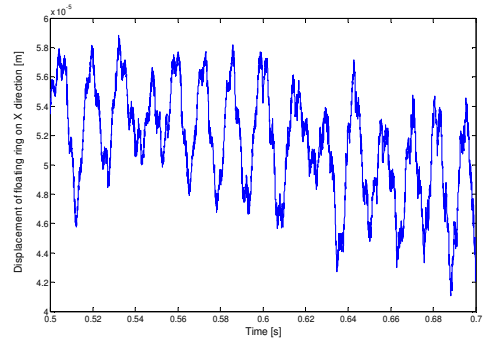

(b)

**Figure 7. Bending vibration of floating ring: (a) on X direction (b) on Y direction**

These results are derived based on the ‘zero’ boundary conditions which mean that either journal or floating ring vibrates from the origin of the coordinate system at the beginning. The boundary conditions are not reasonable, of course, which cause vibration curves not stable until 0.5s in the simulation and after that, results converge to a stable vibration curve gradually.

The spectra of the steady state vibration of journal and floating ring can be seen in figure 8. Bending vibration of journal mainly occurs at the rotational speed around 400rad/s, approximately half of the rotational speed of floating ring, which appear more obvious than the synchronous vibration. Vibration with approximately the same frequency is appeared in the floating ring. In similar with the ordinary journal bearings, predicted results also demonstrate the existence of such nonlinear behaviours as half speed oil whirl for the floating ring bearing of turbocharger.

It is centrifugal forces that mainly stimulate bending vibration of rotor system. Once it exceeds a permissible value, bearing of course might be worn which affects seriously service life of the whole turbocharger. According to the knowledge of rotordynamics, centrifugal forces are proportional to imbalance moment as well as the square of rotational velocity. Consequently to obtain high centrifugal forces, a higher imbalance

moment  $5 \times 10^{-6} \text{ kg} \cdot \text{m}$  is imposed on the turbine impeller of the model and set the rotational speed at the value of  $8000 \text{ rad/s}$ , while the speed of the floating ring is estimated to be approximate  $3000 \text{ rad/s}$ . Figure 9 show the predicted bending vibration of journal and floating ring respectively.

Since imbalance centrifugal forces are too large for the hydrodynamic oil film forces, the collision of the turbocharger core and the floating ring bearing will happen. It is clear to see from bending vibration of floating ring, the vibration curve has touched the lower and upper limits of bearing that indicates the collision of floating ring and bearing happens. If turbocharger works in this condition for a long time, the floating ring bearing would be destroyed and some serious faults might happen.

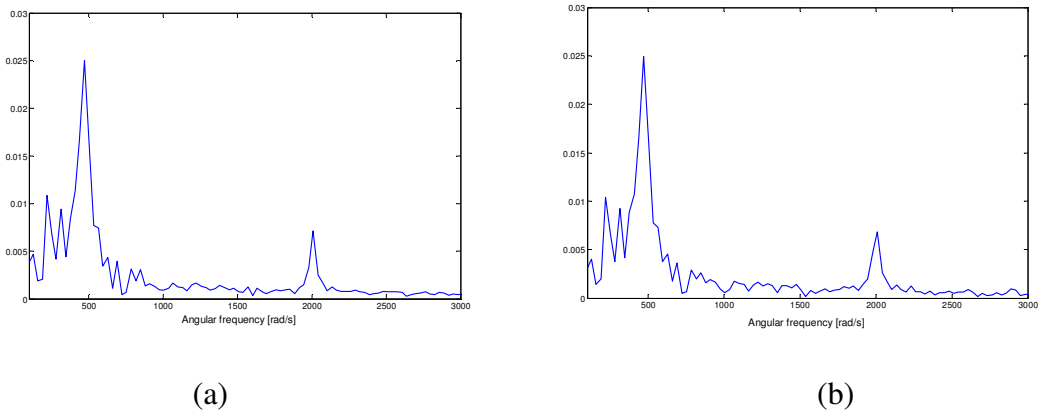

**Figure 8. Spectra of bending vibration on X direction:  
(a) Spectra of journal (b) Spectra of floating ring**

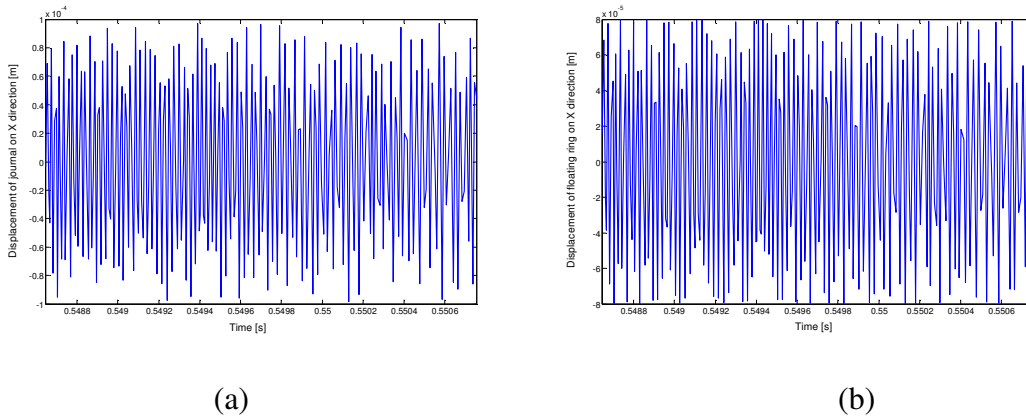

**Figure 9. Bending vibration of journal and floating ring on X direction:  
(a) bending vibration of journal (b) bending vibration of floating ring**

#### 4. Conclusion

The present paper developed a comprehensive model for turbochargers. To simulate bending vibration, a finite element model with six mass nodes linked by five shaft segments is used to describe the rotor system of turbocharger. After forming mass, stiffness and damping matrices, system motion differential equation and equation of floating ring have established. Apart from gravity, another two major stimulating forces

such as rotor imbalance and nonlinear hydrodynamic fluid forces have been studied respectively. In the meantime, rub impact between solid parts of floating ring bearings have also been concerned. Newmark integration method is introduced here to deal with the solution of nonlinear differential equations. Following model development, bending vibration of an automotive turbocharger haben been prediceted under the influences of rotor imbalance imposing on its impellers. After being validated in the future, this mathematical model could be introduced for turbochargers monitoring.

## References

1. TS Zheng and N Hasebe, 'Calculation of equilibrium position and dynamic coefficients of a journal bearing using free boundary theory', *Journal of Tribology*, Vol 122, pp 616-621, 2000.
2. P Klit and J W Lund, 'Calculation of the dynamic coefficients of a journal bearing using a variational approach', *Journal of Tribology*, Vol 108, pp 421-425, 1988.
3. Q Shuai, LM Wu and ZY Chen, 'Solution of the three lobe's journal centre orbit under steady-state force', *Mechanical Engineering and Automation*, 2006.
4. L S Andres and J Kerth, 'Thermal effect on the performance of floating ring bearings for turbochargers', *Journal of Engineering Tribology*, Vol 218, pp 437-450, 2004.
5. J Kerth, 'Prediction and measurement of the rotordynamics response of an automotive turbocharger with floating ring bearings', Ms thesis, Mechanical Engineering Department, Texas A&M University, 2003.
6. TS Zheng and N Hasebe, 'Nonlinear dynamic behaviours of a complex rotor-bearing system', *Journal of Applied Mechanics*, Vol 67, pp 485-495, 2000.
7. GY Shen, ZH Xiao, W Zhang and TS Zheng, 'Nonlinear behaviours analysis of a rotor supported on fluid film bearings', *Journal of Vibration and Acoustic*, Vol 128, pp 35-40, 2006.
8. M Cheng, G Meng and JP Jing, 'Numerical and experimental study of a rotor-bearing-seal system', *Mechanism and Machine Theory*, Vol 42, pp 1043-1057, 2007.
9. H F Castro, K L Cavalca and R Nordmann, 'Whirl and whip instabilities in rotor-bearing system considering a nonlinear force', *Journal of Sound and Vibration*, Vol 317, pp 273-293, 2008.
10. C Holt, L S Andres and S Sahay, 'Test response and nonlinear analysis of a turbocharger supported on floating ring bearings', *Journal of Vibration and Acoustics*, Vol 127, pp 107-115, 2005.
11. J S Rao, 'Rotor Dynamics', New Age International (P) Ltd., India, 1996.
12. L Sperling, B Ryzhik, Ch Linz and H Duckstein, 'Simulation of two-plane automatic balancing of a rigid rotor', *Mathematics and Computers in Simulation*, Vol 58, pp 351-365, 2002.
13. A Cameron and C M Ettles, 'Basic lubrication theory', Ellis Horwood, Cameron, 1981.
14. DX Zhu. 'Turbocharger and turbocharger', Mechanical industry press, China, 1992.