



# University of HUDDERSFIELD

## University of Huddersfield Repository

Elforjani, Badradin, Feng, Guojin, Gu, Fengshou and Ball, Andrew

Energy Harvesting Based Wireless Sensor Nodes for The Monitoring Temperature of Gearbox

### Original Citation

Elforjani, Badradin, Feng, Guojin, Gu, Fengshou and Ball, Andrew (2016) Energy Harvesting Based Wireless Sensor Nodes for The Monitoring Temperature of Gearbox. In: COMADEM 2016, the 29th International Congress on Condition Monitoring and Diagnostic Engineering Management, 20th-22nd August 2016, Empark Grand Hotel in Xi'an, China.

This version is available at <http://eprints.hud.ac.uk/id/eprint/29479/>

The University Repository is a digital collection of the research output of the University, available on Open Access. Copyright and Moral Rights for the items on this site are retained by the individual author and/or other copyright owners. Users may access full items free of charge; copies of full text items generally can be reproduced, displayed or performed and given to third parties in any format or medium for personal research or study, educational or not-for-profit purposes without prior permission or charge, provided:

- The authors, title and full bibliographic details is credited in any copy;
- A hyperlink and/or URL is included for the original metadata page; and
- The content is not changed in any way.

For more information, including our policy and submission procedure, please contact the Repository Team at: [E.mailbox@hud.ac.uk](mailto:E.mailbox@hud.ac.uk).

<http://eprints.hud.ac.uk/>

# ENERGY HARVESTING BASED WIRELESS SENSOR NODES FOR THE MONITORING TEMPERATURE OF GEARBOX

Badradin Elforjani, Guojin Feng, Fengshou Gu and Andrew Ball

<sup>1</sup>Centre of Efficiency and Performance Engineering, University of Huddersfield, Queensgate,  
Huddersfield HD1 3DH, UK

U1369490@hud.ac.uk

**Abstract.** Temperatures are effective indicators of the health of many machines such as the wind turbine gearboxes, bearings, engines, etc. This paper presents a novel wireless temperature sensor node powered by a thermal harvester for monitoring the status of gearboxes. A thermoelectric generator module (TEG) is optimized to harvest the electrical power from a heat source such as the gearbox undergoing such monitoring. The power generation from this method is obtained based on temperature gradients emanated by sandwiching the TEG between the two aluminum plates. One plate is exposed to the heat source and has the role of a heat collector, whereas the other plate, mounted with a low profile heat-sink, acts as a heat spreader. The harvested power is then used to power a wireless temperature node for condition monitoring, resulting in a powerless and wireless monitoring system.

To evaluate the system, an industrial gearbox is monitored by the designed temperature node. The node is fabricated using a TEG module; an LTC3108 DC-DC converter for boosting the voltage, a super-capacitor for energy storage and a CC2650 sensor tag for measuring the temperature of the gearbox. The temperature data is transferred via the Bluetooth Low Energy and then monitored using portable monitoring devices, such as a mobile phones. The results obtained show the system can provide a continuous monitoring of the temperature information.

**Keywords:** energy harvesting; wireless sensor networks; condition monitoring; temperature; thermoelectric generator.

## 1 Introduction

With the increasing complicity of industrial machines, the maintenance cost has been growing quickly as well. Thus, there is an urgent need on reducing the maintenance cost. Temperature monitoring is one of the most commonly and extremely known monitoring techniques used in the industry machines. It provides useful monitoring information about the condition of the components in the machines. The gearbox is an important component in many industrial machines. The maintenance cost for the gearbox

is high, like the other higher failure rate components such as electric system and hydraulic system. As the rotating speed and load of different stages of gearbox change from time to time, this brings great challenges to the condition monitoring of gearbox [1, 2, 3]. Cost performance is another factor that should be taken in to account in gearbox condition monitoring[4].

Temperature is an important health indicator for many industrial machines, including the gearbox. An unexpected temperature arise in one component may indicate poor lubrication, overload and or possibly ineffective passive or active cooling [4, 5], which are considered to be a major root cause for gearbox fatigue, driving gearbox failure modes and affecting gearbox life. On the other hand, the normal operation of the machine also causes its body temperature usually higher than its ambient environment. This small amount energy can be harvested using thermoelectric generators (TEG), which can convert temperature difference into electricity using a so called Seebeck effect [6-9]. Many applications have been used with TEGs such as structural health monitoring applications [10,11].

In recent years, wireless sensor network (WSN) has gained great attention in the condition monitoring field due to its inherent advantages, such as low cost and easy installation. Although the WSN has removed the long communication cables of the measurement system, the wireless sensor node still needs dedicated power line or regular charging - replacing batteries [9, 12]. Harvesting energy from the exhaust heat on the machines can be an ideal solution for providing power to the WSN node.

. Many kinds of wireless transmission technology have already been used such as ZigBee, Bluetooth and ANT. Bluetooth V4.0 is the most recent version of Bluetooth wireless technology. Bluetooth Low Energy (BLE) has been designed as a low power solution for control and monitoring applications [13]. It is particularly suitable for those devices that need transfer small quantity of data and within relatively short range such as medical instruments, health management device and remote controller. BLE technology can remove the inconvenience of wired transmission and eliminate the disadvantage that high power consumption of ordinary wireless transmission. In addition, more and more smartphones gain support for Bluetooth low energy, the possibilities of using the technology for new types of applications increase. In addition, WSN node appropriated for using in ultra-low power consumption and energy harvesting support has been developed for the purposes of environmental monitoring [12].

## **2 Theory of Thermal Energy Harvesting**

Thermal energy harvesting (TEH) is the process of converting thermal energy to electrical energy by using a thermoelectric generator (TEG) made of thermocouples. Thermoelectric generators (TEGs) are a device that converts thermal energy directly into electrical energy. TEGs are solid state devices which mean that they have no moving parts during their operations. Together they produce no noise and involve no harmful agents and therefore are the most widely adopted devices for waste heat recovery. The thermal energy harvesting is based on the Seebeck effect of thermoelectric device which shows that an electrical current is present in a series circuit of two dissimilar metals provided the junctions of the two metals are at different temperature, because

the metals responded differently to the temperature difference creating current loop and a magnetic field.

Thermoelectric devices are comprised of a number of semiconductor elements of both N-type and P-type which are connected electrically in series and thermally in parallel as shown Fig.1. When heat flows through the cell the N-type components are loaded negatively (excess of electrons) and P-type components are loaded positively (default electron) resulting in the formation of electric flow. In addition, if heat is flowing between the top and bottom of the thermoelectric device (forming a temperature gradient) a voltage will be produced and thus an electric current will flow. Conversely when a voltage is applied to it, it can move heat from one side to other side. This is called Peltier effect. Thermoelectric devices are comprised of a number of semiconductor elements of both N-type and P-type which are connected electrically in series and thermally in parallel.

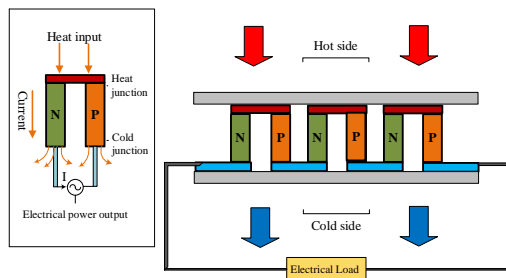

**Fig. 1** Thermal to electric conversion with thermoelectric

### 3 System Design

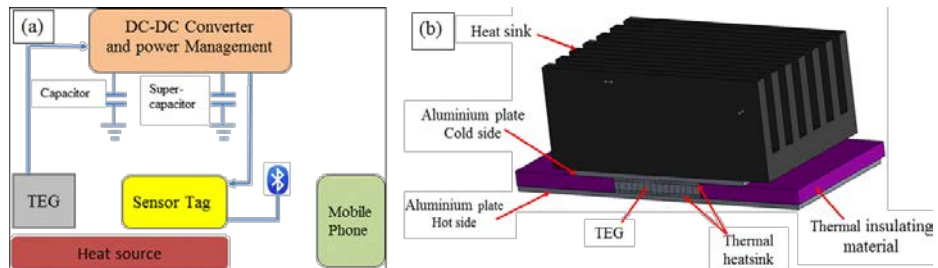

**Fig. 2.** (a) Block diagram of the autonomous sensor node and (b) Structure of the thermal design.

There are three steps in determining the design of a thermal energy harvesting for wireless sensor node as shown in Fig.2-(a), that include the following:

### 3.1 Thermal energy harvesting generator

The basic construction of the thermal energy harvesting generator is shown in Fig. 2(b), which consists of a TEG, thermal material, and two pieces of thin aluminum plates have been chosen, one piece to work as a heat collector for hot side, whereas another one acts as a heat spreader for cold side. This is due to the large thermal conductivity of aluminum. The TEG is located between the thin aluminum plate and heat sink through the use of high efficiency grease and a thermal insulating material (thermal heat sink transfer double side adhesive). The choice of a good TE module usually plays the most important part in the design of a successful TE generator. The temperature difference between hot side and cold of the Peltier module determines the value of the power output of the TEG.

### 3.2 Voltage Booster Design

Block diagram of the autonomous sensor node for measuring the temperature of gearbox is shown in Fig. 1-(a). The power supplied by the thermoelectric generator is boosted by a DC-DC converter and power management circuit to charge a super-capacitor. The thermoelectric generator (TEG) has been employed as the energy harvesting source to power up the wireless sensor node for condition monitoring. This provides ultra-low power consumption, low cost, miniature design and low cost maintenance and energy harvesting support. The measured data are transmitted by Bluetooth Low Energy from the sensor Tag to mobile phone.

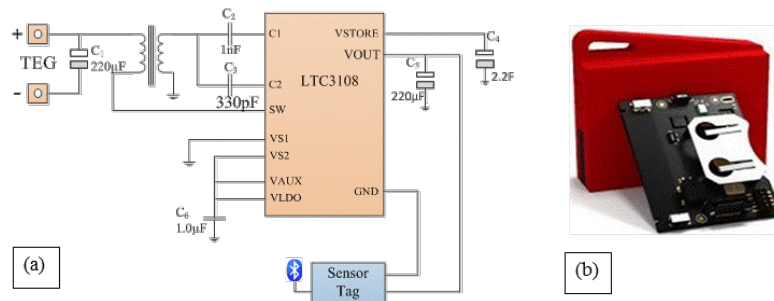

**Fig. 3.** a) Basic schematic diagram of the autonomous sensor Tag and (b) sensor tag CC2650K

A basic schematic diagram of the Sensor Tag is shown Fig. 3-(a). The DC-DC boost converter was designed for boosting the voltage from a thermoelectric generator with temperature difference [15]. The circuit LTC3108 is introduced as DC-DC boost converter is set to provide regulate  $V = 3.3V$  supply to the Sensor Tag. The LTC3108 can boost input voltage ranging from 20mV to 400mV and generates a higher output voltage ranging from 2.35V to 5V. Simple in design and low in cost, the circuit can boost the small voltage from the TEG in a convenient way. For this design ( $B_{i2}T_{e3}$ ) based, TEG CP85438 [16] was been chosen as the TE module. It is chosen due to its low cost, small size and acceptable values of thermal conductance and power factor.

To maintain a high temperature difference, a good heat sink is employed to increase the heat dissipation from the cold side to the air and thermal insulation material is added surrounding the Peltier module to reduce the heat transmission through the air. The module is designed to be placed on the heat source by its hot side, whereas on its cold side a heat sink is placed to the ambient air.

### **3.3 WSN node**

The new Sensor Tag is based on the CC2650 wireless MCU, offering 75% lower power consumption than previous Bluetooth Smart products. The new sensor tag now includes 10 low-power MEMS sensor in a red rubber case as shown in Fig. 3-(b). It is selected on the sensor node because it integrates one processor for data acquisition and signal processing and also a specific processor for BLE communication [13]. This allows the Sensor Tag to be battery power, and offer years of battery lifetime from a single coin battery [17]. WSN node described in this paper is designed for use in the field conditions to monitor industrial parameters. The super-capacitor is considered for using it as the main power source of WSN node. It is used when there is no energy harvesting or if it is not sufficient for the continuous node operation. It also accumulates energy for a relative long time and then provides power to the sensor node work for short period, during which signal is collected and transmitted to the central device. More details about the analysis and application of super-capacitor in WSN can be found in [18].

## **4 Experimental Studies**

### **4.1 Performance Analysis on Gearbox**

To evaluate the system, a gearbox is used as heat source by using thermoelectric generator as a power source to supply the temperature node of low-power circuit, the test rig as shown in Fig. 4-(b). The gearbox of test rig consists of three main parts as shown in. 15 kW three phase induction motor, two gearboxes connected back to back via flexible coupling and DC motor. Therefore, to simulate a variable loads and variable speed operating conditions of common industrial machine the tests were carried out based on changing the AC motor speed while a fixed load applied. During the test AC motor is operated for one hour for each test and the speed is set to 70% and 100% (full speed) with full load. The test is designed to evaluate the transfer efficiency of the TE module [19-20].

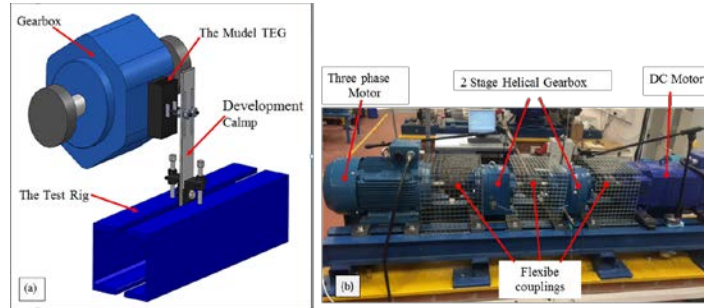

**Fig. 4.** (a)The module TEG attached the gearbox and (b) The test Rig

The result shows the temperatures difference of the gearbox on hot side temperature, cold side temperature, ambient temperature and open circuit voltage. This is under different speeds 70% (T1) and 100% (T2) (full speed) and full load as shown in Fig. 5-(a). It can be seen that the test under full speed and full load (T2) has the highest temperature and therefore, produced the highest value of voltage and current. However, the test under 70% speed (T1) produced lower voltage and current because the temperature was lower, and the difference temperature of both tests are nearly constant value.

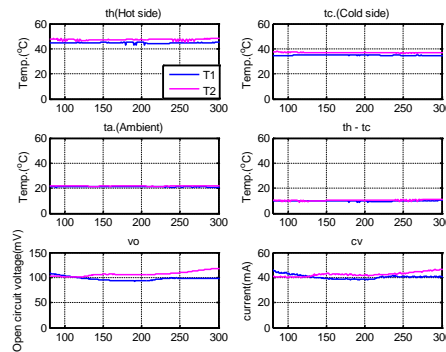

**Fig. 5.** Result of the temperature difference of gearbox

## 4.2 Gearbox Temperature Monitoring Results

The module TEG is characterized by using a gearbox on the test rig as a heat source. During the test, the module TEG was attached with the gearbox by clamp to be fixed properly on vertical position as shown in Fig. 4-(a), while the room temperature was in the range 21-25°C. The design is attached into the gearbox with DC-DC and sensor Tag as shown in Fig. 6-(a).

Then the gearbox run for half hour, and then the input of DC-DC booster converter connected to the module. As results the output of DC-DC was 3.3V to supply the Sensor Tag. The super-capacitor (2.2F, 5.5V) starts to charge when the output voltage reaches regulated 3.3 V and with constantly applied heat source it can be full charged to 5.2V. Time needed for charging the super-capacitor to reach fully charged is depended by

power provided by the TEG. Therefore, it waited to charge the super-capacitor which took about three hours to reach about 5.2V and then connected the Sensor Tag. The temperature data which is transferred via the Bluetooth Low Energy and then monitored using portable monitoring devices, such as a mobile phones.

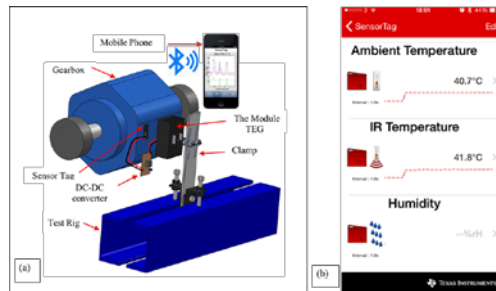

**Fig. 6.** a) Test system, b) Screenshot of sensor Tag of mobile phone

The sensor tag includes two temperature sensors. One is placed under the sensor tag attaches the gearbox case directly measures and the other is on the top of the sensor tag and measures the ambient temperature. Information about the gearbox temperature and the ambient temperature are sent via BLE to a smart mobile phone for monitoring. Fig. 5 shows a screenshot of sensor Tag software which installed on a mobile phone for this purpose. It can be seen that the gearbox case which is measured by the IR contactless temperature sensor is slightly higher than the ambient temperature measured by the ambient sensor. Where, the gearbox case temperature is 41.8°C while the ambient temperature is 40.7°C.

## 5 Conclusion

The research to date has demonstrated that it is viable to harvest sufficient thermo energy of a machine to power up a wireless temperature node that is used to monitor the health and performance of the machine. Thermoelectric generator (TEG) has been employed as the energy harvesting source to power up the wireless sensor node for condition monitoring. It can convert the widely available waste heat from machines to electrical energy. Bluetooth is employed as the wireless transmission protocol due to its low power consumption and it's widely availability on current portable smart phones and tablets. By using the designed TEG module together with the highly integrated sensor Tag, the temperature of the gearbox is successfully measured by the sensor Tag and received on a smart phone without providing external power or battery to the sensor Tag.

## Reference

1. Crabtree, C., Y. Feng, and P. Tavner. Detecting incipient wind turbine gearbox failure: a signal analysis method for on-line condition monitoring. in Scientific Track Proceedings of European Wind Energy Conference. 2010.



2. Lu, B., et al. A review of recent advances in wind turbine condition monitoring and fault diagnosis. in *Power Electronics and Machines in Wind Applications*, 2009. PEMWA 2009. IEEE. 2009. IEEE.
3. Tavner, P., Review of condition monitoring of rotating electrical machines. *Electric Power Applications*, IET, 2008. 2(4): p. 215-247.
4. Guo, P. and N. Bai, Wind turbine gearbox condition monitoring with AAKR and moving window statistic methods. *Energies*, 2011. 4(11): p. 2077-2093.
5. Tavner, P., L. Ran, and J. Penman, Condition monitoring of rotating electrical machines. Vol. 56. 2008: IET.
6. Bottner, H. Thermoelectric micro devices: current state, recent developments and future aspects for technological progress and applications. in *Thermoelectrics*, 2002. Proceedings ICT '02. Twenty-First International Conference on. 2002.
7. Mastbergen, D. and B. Willson. Generating light from stoves using a thermoelectric generator. in *ETHOS International Stove Research Conference*. 2005.
8. Yu, C. and K. Chau, Thermoelectric automotive waste heat energy recovery using maximum power point tracking. *Energy Conversion and Management*, 2009. 50(6): p. 1506-1512.
9. Xin, L. and Y. Shuang-Hua. Thermal energy harvesting for WSNs. in *Systems Man and Cybernetics (SMC)*, 2010 IEEE International Conference on. 2010.
10. Palacios, R. and M.Z. Li. Electrical properties of commercial thermoelectric modules. in *Fourth European Workshop on Thermoelectrics*, ETS. 1998.
11. Mastbergen, D., B. Willson, and S. Joshi, Producing light from stoves using a thermoelectric generator. 2012.
12. Eakburanawat, J. and I. Boonyaroonate, A Thermoelectric Battery Charger System with Maximum Power Point Tracking Technique. 2006.
13. Lin, Z.-M., et al. Bluetooth Low Energy (BLE) based blood pressure monitoring system. in *Intelligent Green Building and Smart Grid (IGBSG)*, 2014 International Conference on. 2014. IEEE.
14. Andersson, T., Bluetooth Low Energy and Smartphones for Proximity-Based Automatic Door Locks. 2014.
15. LTC3108 Ultralow Voltage Step-Up Converter and Power Manager, L.T.C. 2010. Automation & computing, University of Strathclyde 2015. Glasgow UK
16. Prijic, A., et al., Thermal energy harvesting wireless sensor node in aluminum core PCB technology. *Sensors Journal*, IEEE, 2015. 15(1): p. 337-345.
17. Peltier. <http://www.alldatasheet.com/datasheet-pdf/pdf/307804/CUI/CP85438.html>].
18. Instruments, T. Sensor. Tag. CC2650STK. [http://processors.wiki.ti.com/index.php/CC2650\\_SensorTag\\_User's\\_Guide](http://processors.wiki.ti.com/index.php/CC2650_SensorTag_User's_Guide).
19. Rgeai, M.N., Helical Gearbox fault detection using motor current signature, in *Engineering and Physical Sciences*. 2007, The University of Manchester
20. Wahg, K., Vibration monitoring on electrical machine using vold-Kalman filter order Tracking, in *The Department of Mechanical and Aeronautical*. 2008, Pretoria: South Africa. p. 17.
21. Toliyat, H.A., *Electric Machines: Modeling, Condition Monitoring, and Fault Diagnosis*. 2013, GB: CRC Press Inc.

