



University of HUDDERSFIELD

University of Huddersfield Repository

Abusaad, Samieh, Benghozzi, Ahmed, Brethee, Khaldoon F., Gu, Fengshou and Ball, Andrew

Investigating the Effect of Water Contamination on Gearbox Lubrication based on Motor Control Data from a Sensorless Drive

Original Citation

Abusaad, Samieh, Benghozzi, Ahmed, Brethee, Khaldoon F., Gu, Fengshou and Ball, Andrew (2014) Investigating the Effect of Water Contamination on Gearbox Lubrication based on Motor Control Data from a Sensorless Drive. In: Proceedings of the 3rd international workshop and congress on eMaintenance: June 17-18 Luleå, Sweden : eMaintenance, Trends in technologies & methodologies, challenges, possibilities and applications. Luleå tekniska universite, Luleå, pp. 61-67. ISBN 978-91-7439-972-1

This version is available at <http://eprints.hud.ac.uk/id/eprint/21792/>

The University Repository is a digital collection of the research output of the University, available on Open Access. Copyright and Moral Rights for the items on this site are retained by the individual author and/or other copyright owners. Users may access full items free of charge; copies of full text items generally can be reproduced, displayed or performed and given to third parties in any format or medium for personal research or study, educational or not-for-profit purposes without prior permission or charge, provided:

- The authors, title and full bibliographic details is credited in any copy;
- A hyperlink and/or URL is included for the original metadata page; and
- The content is not changed in any way.

For more information, including our policy and submission procedure, please contact the Repository Team at: E.mailbox@hud.ac.uk.

<http://eprints.hud.ac.uk/>

Investigating the Effect of Water Contamination on Gearbox Lubrication based on Motor Control Data from a Sensorless Drive

Samieh Abusaad
Centre for Efficiency
and Performance
Engineering,
University of
Huddersfield,
Huddersfield, U.K.

Ahmed Benghozzi
Centre for Efficiency
and Performance
Engineering,
University of
Huddersfield,
Huddersfield, U.K.

Khaldoon F. Brethee
Centre for Efficiency
and Performance
Engineering,
University of
Huddersfield,
Huddersfield, U.K.

Fengshou Gu
Centre for Efficiency
and Performance
Engineering,
University of
Huddersfield,
Huddersfield, U.K.
f.gu@hud.ac.uk

Andrew Ball
Centre for Efficiency
and Performance
Engineering,
University of
Huddersfield,
Huddersfield, U.K.
A.ball@hud.ac.uk

ABSTRACT

Water is one of the most significant destructive contaminations to lubricants which in turn lead to more power consumption and early damage to rotating machines. This study explores the effect of water contents in gearbox lube oil on the responses of electrical supply parameters. A two stage gearbox based mechanical transmission system driven by a sensorless variable speed drive (VSD) is utilised to investigate experimentally any measurable changes in these signals that can be correlated with water contamination levels. Results show that the supply parameters obtained from both external measurements and the VSD control data can be correlated to the contamination levels of oil with water and hence can be based on for an instant diagnosis of water contamination. Particularly, the voltage and hence the power responses are more sensitive to the water contents than that of current because the VSD regulates more the voltage to adapt the small load changes due to the water induced lubrication degradation. Simultaneously, vibration also shows changes which agree with that of power supply parameters.

Keywords

Sensorless VSD, Oil quality, Water in Oil Contamination, Motor Current Signature, Condition Monitoring,

1. INTRODUCTION

The main function of any lubricating oil are minimizing the friction between rotary and fixed machine parts, consequently reducing wear and temperature which lead to high machine efficiency [14]. Deterioration of lube oil is often one of the main causes of machine breakdowns. A study conducted by Rabinowicz [11] shows that corrosion due to water in oil causes about 20% of all damages to mechanical equipment. Hence, water contamination detection has attracted high attention as to avoid catastrophic failures and increase the life of equipment. Main lubricant problems are from the contamination with water and dust. Corrosion due to water in oil, existence of incorrect additional fluids and failure of the oil itself due to temperature and heavy operational conditions are the most common issues from lubricant degradation [15].

The efficiency, life time and reliability of gearboxes and rotary systems are subjected to the quality of lubricating oil used. Therefore, it is important to monitor the condition of lubrication

oil to ascertain any degradation is progressing within the oil. The common technique used in industry for monitoring the oil quality is offline chemical and physical analysis. Samples of lube is normally taken every certain period and sent to chemical and physical laboratories for analysis and reporting the oil condition. Obviously, this approach usually is at high cost and cannot provide results timely

The survey in [9] has presented a review of lubricating oils condition monitoring techniques. They found that viscosity based equipment have better lubrication degradation feature coverage and lower cost. They also stated that oil viscosity is the most useful performance parameter that can reflect oil health and has been used as a standard feature to monitor the lubrication oil status.

Different new techniques have been developed to monitor the quality of oil online. For instance, work in [8] developed an online lubrication oil health monitoring and prognosis technique. Kinematic viscosity and dielectric constant physical simulation of the lubrication oil degradation due to water and the particle filtering algorithm is utilised. However, viscosity and dielectric sensors are required to implement the suggested technique.

In reference [1] an infrared (IR) sensing technique was suggested for online oil quality condition monitoring. The sensor is based on the evaluation of the oxidation number from the absorbed IR within a selected fixed narrowband IR filters. Additionally, the viscosity index (VI) and the base number (BN) of lube oils have been used to evaluating the oil quality in [10]. A multivariate calibration scheme has been used to determine the VI and the BN for the motor oils by applying the partial least squares (PLS-1) to the FTIR data.

Vibration signals together with advanced lubrication oil modelling schemes have been employed in [4] to provide corrosion related faults due to lubrication quality in aerospace gearboxes. However the performance of developed technique was not yet fully tested in terms of validating the reliability and accuracy.

The relationship between oil condition, i.e. lubricant viscosity and vibration signature was studied in [15], in which it is stated that some vibration features can be correlated with the oil viscosity. However the specified features have been failed in many experimental conditions.

Review the literature shows that the detection of gearboxes oil quality degradation, i.e. water contamination, is not well explored. Most techniques employed in industry are by offline monitoring, where the actual state of the lube cannot be determined instantaneously. Additionally, the available online techniques are not always applicable and expensive to apply. According to the research by [2], wind turbine and all other gearboxes application industries spend a considerable amount of money to solve problems and damages due to lubricating oil contamination.

In addition, the effects of water contamination levels has not been studied on both power supply parameters such as terminal current and voltage which have been shown to be effective measurements for monitoring mechanical faults[18][19]. Moreover, there is no known work so far studies the potential of using signatures from current, control data for diagnosing lubrication problems..

Therefore, this study focuses on the development of water contamination monitoring methods based on electrical supply parameters. The possible effects of water contamination are reviewed firstly. Then a symmetric experimental investigation was carried out based on an industrial gearbox system running with different water contents. Through direct comparisons of different supply parameters between different water contents the diagnostic capability of these supply parameters is examined in line with corresponding vibration responses.

2. EFFECT OF WATER-IN-OIL ON GEARBOX TRANSMISSION SYSTEMS

Water in oil is the most destructive contaminant when mixed with lubricating oils. It causes significant chemical and physical changes [2]. Details on the negative consequences of water contamination in gearboxes oil can be found in [6] and [15]. The studies [3] and [20] shows that the most significant and immediate consequence is the clear changes in lubricant viscosity. It means that the dynamic and static behaviour of gearbox transmission systems will also change correspondingly.

2.1 Dynamic Effect

Based on gear lubrication mechanisms, the increase of viscosity will maintain more oil on the surfaces of meshing teeth and hence likely to form thicker hydrodynamic films, leading to a reduction of frictional force. On the other hand, the decrease of viscosity will lead higher friction. Furthermore, as the occurrence of tooth meshing is a time-varying process according to mainly the meshing period, it is expected that the change of frictional forces will alter the vibration responses of gearbox at meshing frequencies and their high order harmonics. As shown in [15], vibration spectrum is strongly related to the lubricant viscosity in a high frequency range from 2300 Hz to 7000Hz based on a 0.34kW gearbox.

In addition, it is also likely that this change of tribological behaviour will affect the dynamic responses of components associated with gear shaft rotation frequencies. These components exist because of evitable gear manufacturing errors such as misalignments and accumulative pitch deviations which cause non-uniform meshing process and eventually lead to the change of the dynamic responses at shaft frequencies.

2.2 Static Effect

Obviously, the change of tribological behaviour will also lead to changes of average friction losses. It means that the overall load of the system will be different for different water contents.

Besides, according to the study in [17], the density, viscosity and oil squeezing will also show considerable losses of power, which will reflect on static measurements such as average supply current, voltage and thus the power.

2.3 Detection based on Sensorless Drive

The dynamic effect can be reflected by vibration measurements. However, the vibration may not so sensitive to the static effect. In contrast, previous studies [18] [19] have shown that both dynamic effects and static effects occurring on downstream machines can be observed in motor current signals. Specifically, the dynamic effect can be represented by the sideband components at [16]:

$$f_x = f_s \pm kf_r \quad k = 1, 2, 3, \dots \quad (1)$$

where f_x denotes fault frequency, f_s is supply frequency and f_r is rotor frequency, whereas the amplitude change at the supply frequency can be based to examine the static effects.

Nowadays, VSDs are used more and more in industry for achieving more efficient production. When VSD is under sensorless mode, the motor speed at the setpoint will be maintained relatively stable by compensating any changes due to load disturbances through more advanced control algorithms, which may give more chances to observe these two effects, rather than just using the feature shown in formula (1) based on the high slipage changes under direct voltage/Hz control methods.

As shown in Figure 1, when a speed deviation due to disturbances from the reference is detected by the driver, the speed comparator sends a speed error to the speed control loop which motivates the controller of the torque current component i_q . The output signal from the i_q current controller sets the reference torque required for compensating the effect of the disturbances. The torque reference is then compared with the estimated torque by the torque controller which outputs the required torque voltage component (v_q) to the pulse width modulator (PWM). In the meantime, the field current component (i_d) control loop sets the required flux (ψ). The flux normally kept fixed at the nominal motor value when speeds lower than the rated motor speed. Thought, when the induction motor operates at or higher the rated speed a field weakening is required to prevent exceeding the voltage limit of both the drive and the motor. The field weakening is performed at the flux control loop by a fraction of the rotor angular frequency ($1/\omega_r$). This control process therefore shows that it is possible to observe the changes of oil properties through exploring different control variables.

It is worth mentioning that the sensorless VSDs estimates both motor speed and flux by measuring terminal supply parameters without the need for additional speed measuring device.

3. TEST FACILITY AND PROCEDURES

The test facility employed for this study consists of a mechanical system and a control system. As shown in Figure 2 the mechanical system includes of a 15kW AC induction motor(IM) as the prime driver, two back-to-back two stage helical gearboxes for coupling the AC motor with a DC load generator using flexible spider

rubber couplings. The first gearbox operates as a speed reducer while the second is a speed increaser so that the system maintains sufficient speed for the DC load generator to produce sufficient load to the AC motor through the two gearboxes. The control system consists of a programmable logic controller (PLC) for setting up different speed-load profiles specified by operators, an AC VSD that can

be set either to a sensorless flux vector control mode or V/Hz mode for adjusting the speed of the system, a DC variable speed drive providing a controlled load to the AC motor by regulating the torque of the DC load generator.

All data sets from both data acquisition systems are stored in a PC for post processing and analysis in the Matlab environment.

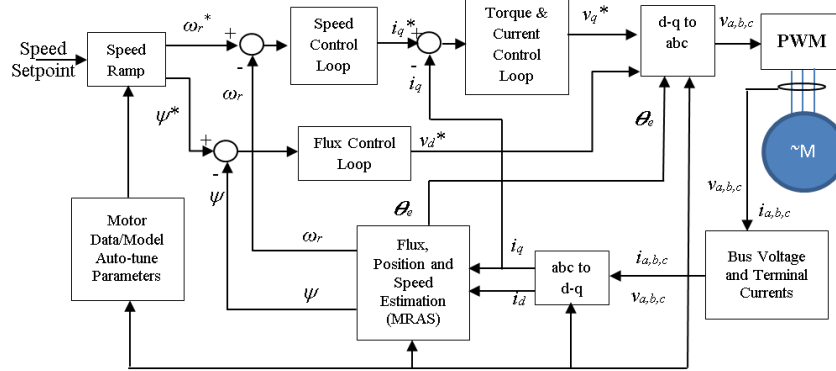

Figure 1. General structure of sensorless VSD

The dynamic data is used for both evaluating the performance of the conventional analysis methods for detecting water contamination problems, and also for benchmarking the developed scheme from the static data.

Experimental studies were carried out by adding different amount of tap water to the lube oil in the first gearbox (GB1), which is a common industrial gearbox with a speed ratio of 3.6 and a power transmission of 10kW at 1450rpm. After a baseline (BL) test when the gearbox was filled with new EP320 gear oil, four incremental water contents: 4.0kppm, 7.0kppm, 30.0kppm and 60.0kppm were tested one by one, which correspond to 0.4%, 0.7%, 3% and 6% water in oil. The first two water contents are below the recommended level [7] and the last two are above the

level, which allows the variation of different measurements underlying to be examined in a wide range for defining their corresponding detection performances.

During the test, the rig operated under five increment load settings: 0%, 25%, 50%, 75% and 100% of the gearbox when it is at its full speed of 1460 rpm, attempting to examine the detection performance under variable load operations which is common scenarios of real applications. Each load setting was for a period of two minutes and changed to next one automatically by the PLC controller. In total, this load cycle lasts 10 minutes. In addition, the VSD was set under sensorless control mode for evaluating the detection capability under this particular mode.

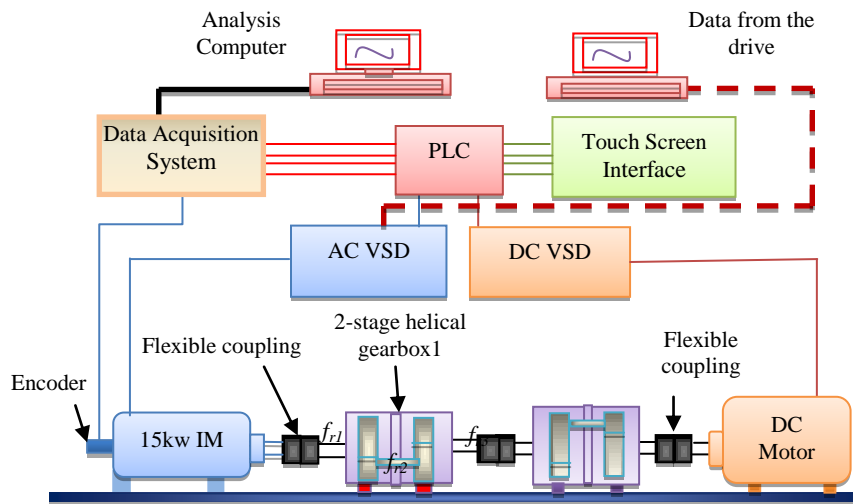

Figure 2. Schematic of test system

To ensure the data quality for reliable comparison the load cycle ran consecutively seven times for each of the water contents. During these repeating operations, the lube temperature in GB1 was observed on-line and reached to 51°C-52°C from the room temperature when the system operating parameters also became stabilised.

By using an automated acquisition procedure based on time advancement, 30 seconds of dynamic data were collected for every load setting. In the meantime, the static data from the VSD were also logged for the entire load cycle. Moreover, oil samples were taken after each incremental water test for measuring the viscosity of the water contained oil.

4. RESULTS and DISCUSSION

The data sets collected were processed by necessary schemes including spectrum analysis, ensemble average and time synchronous average (TSA) to obtain reliable feature parameters for implementing an effective detection of the water contents added to the lube oil in GB1.

4.1 Measurement Validation

To examine the data quality and test reliability, signals including data from the lubricant temperature, speed, current and voltage are processed to obtain their static feature values. Figure 3 shows

these key measurements against testing run numbers for 100% load. It can be seen in Figure 3 (a) that the temperature of lubricant in GB1 increases gradually and reaches stable status at 6th test when the test system becomes stabilised. Moreover, temperature values between different water contents show little difference, showing that these tests were carried out with good repeatability. This repeatability can be also seen from the phase current and the motor speed measurements, which are presented in Figure (3) (d) and (e) respectively. In addition, both of these two parameters show gradual decrease behaviours with the test number because the transient effects including both the higher frictional influences of the test rig and larger resistance values of the electric and electronic components employed in the motors and the VSD control system when they are under lower temperature operation. This transient effect can be seen to be much stronger when the load and speed characteristics in Figure 3 (f) are explored. When the system operates under low temperatures during the 1st test run, the VSD has poorer performance in maintaining the speed of the system to be the setting points, which leads to higher speed under the higher load. On the other hand, when the system reaches its stable value the VSD is able to control the speed to be higher accuracy under different load settings, as shown by the speed results for the 7th run.

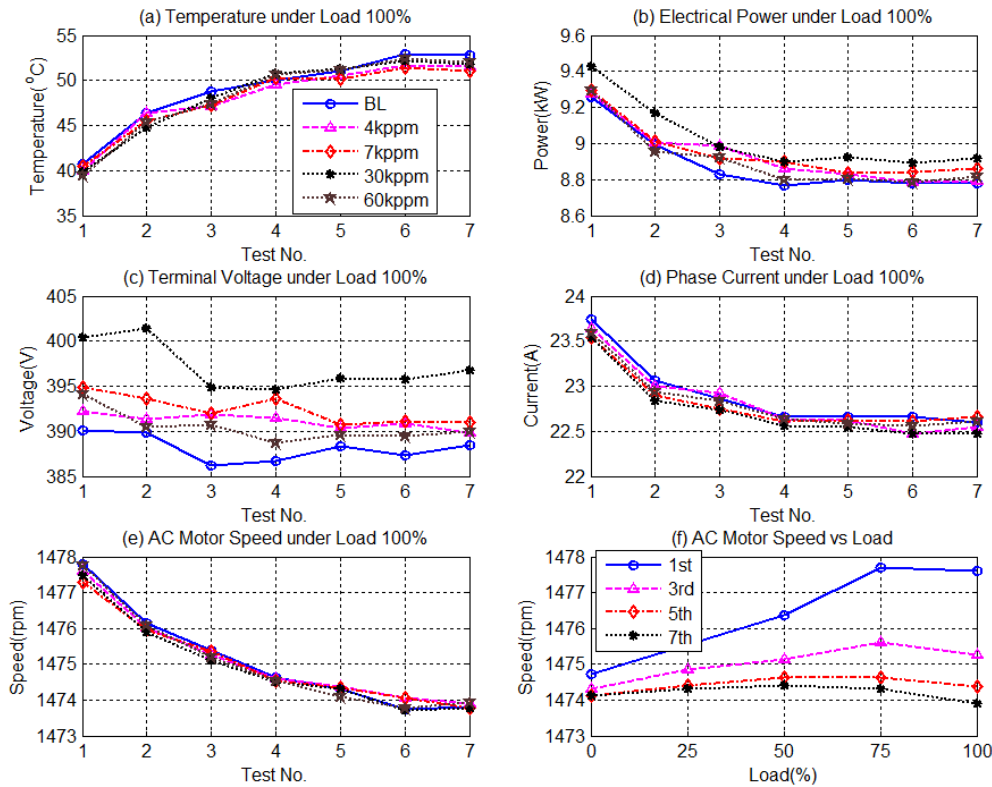

Figure 2. Key measurements variation with test run numbers and water contents

However, the terminal voltage in Figure 3 (c) shows relatively stable over different testing run numbers. Moreover, it shows clear difference between different water contents, showing that it may sensitive to the changes due to lubricant properties. The similar changes between different water contents can also be observed in the electrical power shown in Figure 3 (b) as the power is calculated by multiplying the voltage with the current directly to show the overall power consumption of the system.

Based on these test observations, it can be concluded that the measurements from last test run numbers have less transient effect and be more stable for examining the effect of water contents more accurately. Moreover, it has exposed that the VSD seems to adjust supply voltages more to adapt the changes due to lubrication conditions.

4.2 Effect on Viscosity

As the most important performance parameter of lubricating oils, the viscosity was measured using a Kinexus pro+ rheometer for each water content test and taken as references for representing lubrication deterioration and for comparing the detection performance using supply parameters. Figure 4 shows the representative viscosity values at 50°C and 55°C, which are close to the temperature range where the gearbox is under stable operating. The viscosity shows a slight decrease from that of the base oil for small portion of water content. Then it shows a monotonic increase with water contents, which is slightly different to the result published in [3] and [20]. The effect of very small amount of water decreases the viscosity, up to a certain level i.e. at around 4kppm where it starts to increase due to the interaction of the water droplets. The viscosity starts to be around the amount of that of the base oil when water content is about 60kppm. Nevertheless, this measurement confirms that the water content was added effectively according to the test design. In addition,

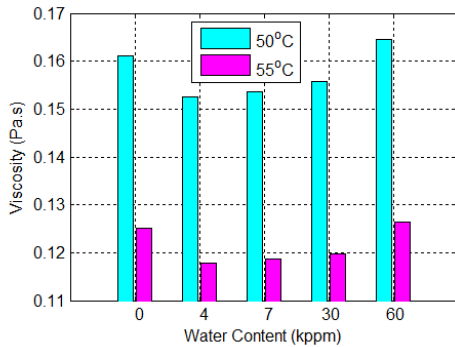

Figure 4. Variation of viscosity with different water contents

In addition, Figure 4 also shows that temperature has more significant influence on the viscosity i.e. the higher temperature corresponding to lower viscosity. This also explains that the electrical power decreases gradually with test run numbers presented in Figure 3.

4.3 Effect on Power Supply Parameters

Further analysis of the dynamic current and voltage signals has found that the dynamic responses such as sidebands of the supply frequency has shown little contestant changes to the water

continents because of high moment of inertia of the test system. Therefore, only the static parameters are discussed further.

Figure 5 presents a comparison of power supply parameters between the lubricants with different water contents. These results were obtained by averaging the results from the 6th and 7th testing runs under 100% in order to give a more reliable result. The terminal voltages in Figure 5(a) and their corresponding power values have shown good correlation with the changes in viscosity. For the base value, the voltage and hence power shows the lowest value, reflecting the good performance of the base oil in reducing the friction because of its relatively high viscosity. For the cases of small water added to the oil such as 4kppm, 7kppm and 30ppm, the viscosity values reduce and lead to poorer lubrication. It means that they need more power to overcome the friction loss to maintain the constant speed operation. Therefore, the electrical power shows higher values for these cases. However, the 30kppm case shows the highest power consumption due to other effects such as more oil squeezing. For the 60kppm case, the viscosity is higher than the base oil and the effect of viscosity may high than that of oil squeezing, which lead to that the power consumption goes lower.

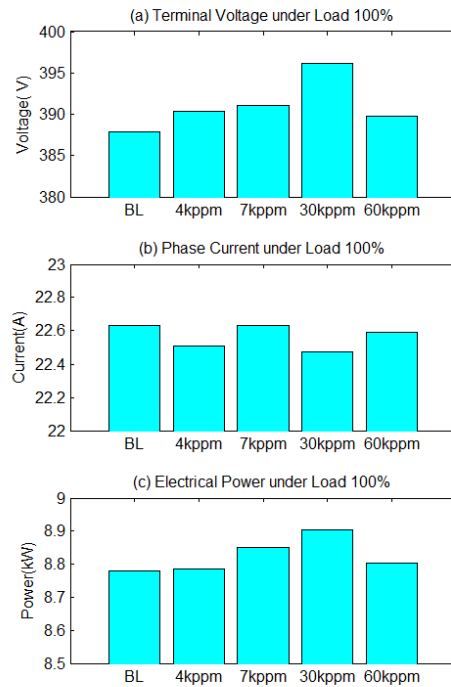

Figure 5. Temperature comparison during 7th test

However, because of the regulation of VSD, the power consumption characteristics are not reflected by the current measurements. Instead, the current measurement shows similar value for different water contents as shown in Figure 5 (b). Therefore, it may not be suitable for detecting the water contamination.

In addition, the control data obtained directly from the VSD also exhibits the same characteristics shown in Figure 5.

These results show that the electrical measurements from a VSD can be used to separate different levels of water contamination. However, both the voltage and current need to be measured in order to obtain the power for a reliable separation even though the voltage measurement shows better performance of detection.

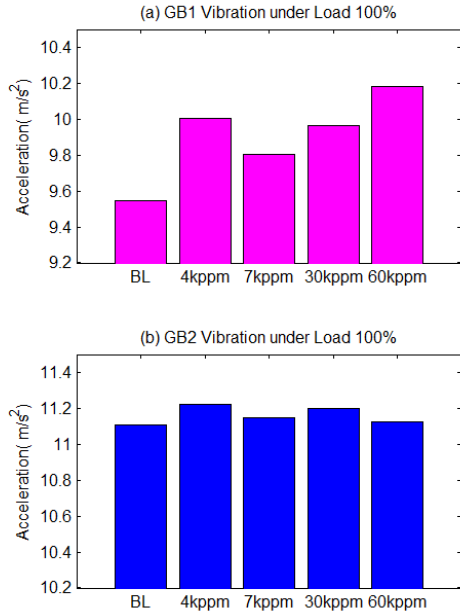

Figure 6. Vibration spectra under different loads and cases

4.4 Effect on Vibration Responses

To show the dynamic effect of the water content, the vibration signals are processed to obtain root mean squared values (RMS) to represent overall level of vibration responses for different water contents. Figure 6 shows the averaged results of the last two test runs. It can be seen that the vibration levels for different water content are higher than that of the base line, which is consistent with the results from the static electrical parameters in that the water degrade the lubrication performances and cause more friction between the surfaces of meshing teeth. Especially, compared with the vibration from GB2 which shows relatively unchanged between different tested cases, the vibration changes of GB1 are clearly significant and can be used to indicate the water contamination.

To understand the vibration change further, the vibration signals are applied with a time synchronous average (TSA) procedure and subsequent order spectrum analyse to suppress noise influences which are not time aligned to the second shaft and hence to obtain vibration which are more associated with gear meshing dynamics. Figure 7 (a) and (b) shows the amplitudes of vibration components at the two mesh frequencies of the two stage gearbox, which is the average amplitude up to the 10th high order harmonics. The vibration at the first mesh frequency which is the high speed stage with low load shows higher amplitudes compared with the baseline and exhibit similar behaviour with that of the static power parameters. The vibration at the second mesh frequency which is the low speed stage with high load also shows higher amplitudes compared with the baseline and that of

the higher speed stage and exhibit more similar behaviour with that of the static power parameters. This shows that the high load stage is more influenced by the change in lubrication which is consistent that the hydrodynamic oil film is less helped because the relative velocity between meshing tooth surfaces changes its direction at the pitch line. In addition, these vibration changes are consistent with that in [15]. Furthermore, the change of vibration responses provide further support that the power supply parameters can reflect the changes in gear lubrication due to water contamination.

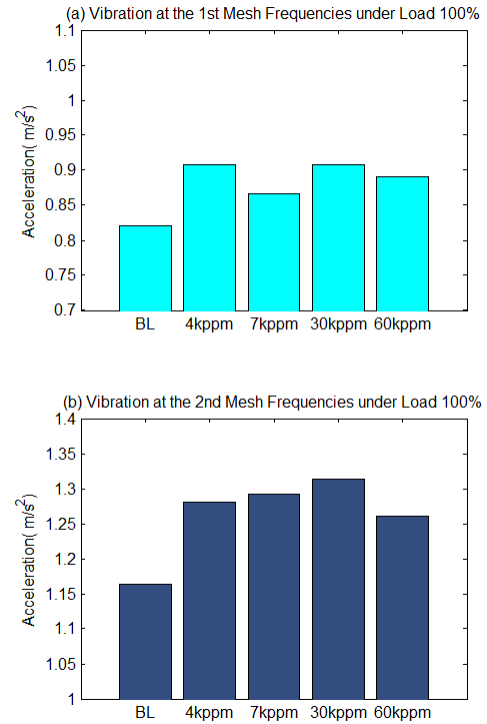

Figure 7. Vibration at mesh frequencies

5. CONCLUSION

In this paper a new cost effective technique is presented to detect gearbox lubricant contamination with water based on power supply parameters. Experimental results shows the viscosity reduces when small portions of water (<30kppm) added to the gear oil while the large portion of water increases the viscosity. Based on a 10kW gearbox rig, this contamination can be measurable using the static power supply parameters including the voltage and power. However, the current values show little change because the VSD adjusts the electrical power supply to adapt to the changes due to the frictional load through regulating more the voltage than the current.

In addition, the results have been supported by vibration response analysis in that the vibration responses at high load stage show much similar change to that of power supply parameters due to the water contents.

Moreover, this study shows that both power supply parameters and vibration responses can be effective measurements to be

based on for performing the instant diagnosis of water contamination so as to prevent further damages to gearboxes running with water contents.

6. REFERENCES

- [1] Agoston OVE, C. Schneidhofer, N. Dorr, and B. Jakoby (2008). "A concept of an infrared sensor system for oil condition monitoring". *Elektrotechnik & Informationstechnik* 125(3), pp. 71–75.
- [2] Bernard J.C. (2004). "Predictive & Preventive Maintenance in Lubricating Systems". *DES-CASE Europe sarl*. Available at: http://www.descase-europe.com/uploads/1256143218_lubricated_systems.pdf
- [3] Jakoby, B. and Vellekoop, M.J.. (2004). "Physical sensors for water-in-oil emulsions". *Sensors and Actuators Published by Elsevier B.V*, 110, pp. 28–32
- [4] Byington, C. S., Brewer, R. C., Meyer, T., and Amin, S. R. (2007). "Gearbox Corrosion Prediction via Oil Condition Sensing and Model Fusion," *STLE 62nd Annual Meeting and Exhibition, Philadelphia*.
- [5] Campbell W S; Jacopini J; 1994, "Suction Roll Pilot Bearing Failure Due to Inadequate Lubrication", *Tappi Journal* , 77(12), pp. 233-236
- [6] Echin, A. I., G. T. Novosartov, T. B. Kondrat'eva. (1983). "Effect of water on lubricating properties of synthetic oils". *Chemistry and Technology of Fuels and Oils*, 19(2), pp. 80-83.
- [7] Jakoby, B., and Vellekoop, M.J. (2004). "Physical Sensors for Water-In-Oil Emulsions". *Sensors and Actuators A*, vol. 110, pp. 28 - 32.
- [8] Junda Zhu, David He, and Eric Bechhoefer. (2013). "Survey of Lubrication Oil Condition Monitoring, Diagnostics, and Prognostics Techniques and Systems" *Journal of Chemical Science and Technology*. 2 (3), pp. 100-115.
- [9] Junda Zhu, Jae M. Yoon, David He, Yongzhi Qu, and Eric Bechhoefer. (2013). "Lubrication Oil Condition Monitoring and Remaining Useful Life Prediction with Particle Filtering". *International Journal of Prognostics and Health Management* ISSN 2153-2648.
- [10] M.A.Al-Ghouthi, Y. S.Al-Degs and M. Amer. (2010). "Application of chemometrics and FTIR for determination of viscosity index and base number of motor oils". *Talanta*, 81, pp. 1096 – 1101.
- [11] Mike Day Pall and Mika Vesala. (2009). "Setting Control Limits for Water Contamination in Hydraulic and Lube Systems". *The 10th Scandinavian International Conference on Fluid Power*. Available at: <http://ebookbrowse.net/the-10th-scandinavian-international-conference-on-fluid-power-pdf-d55044223>.
- [12] Paladugu, A., and Chowdhury, B. (2007) 'Sensorless control of inverter-fed induction motor drives' *Electric Power Systems Research*, 77 pp.619–629
- [13] R.E. Cantley. "The Effect of Water in Lubricating Oil on Bearing Fatigue Life". *ASLE Transactions, American Society of Lubrication Engineers*, 20(3), pp. 244-248; from a presentation at the 31st Annual ASLE Meeting, Philadelphia, Penn.
- [14] Rajeev R. and Harsh Kumar D. (2013). "Effect of Lube Oil Temperature on Turbine Shaft Vibration". *International Journal of Mechanical Engineering and Robotics Research (IJMERR)*, 2(2), pp. 2278 – 0149
- [15] Rui Gomes de Almeida and Linilson Rodrigues Padovese. (2003). "Characterization of oil viscosity alterations in a gearbox through vibration signal analysis". *17th International Congress of Mechanical Engineering (COBEM2003)*. Available at: <http://www.abcm.org.br/pt/wp-content/anais/cobem/2003/html/pdf/COB03-0555.pdf>
- [16] Schoen, R. R. and Habetler, T. G. 1995. Effects of time-varying loads on rotor fault detection in induction machines. *IEEE Trans. Ind. Appl.*, Vol. 31, pp. 900–906.
- [17] Gorla, C., Concli, F., Stahl, K., Hohnet, B. Klaus, M. Schultheiß, H. and Stemplinger, J. (2012) "CFD Simulations of Splash Losses of a Gearbox, , *Advances in Tribology*". *Hindawi Publishing Corporation*, Volume 2012.
- [18] Tian, X., Feng, G. Albraik, A., Gu, F., and Ball, A.D. (2014), "The investigation of motor current signals from a centrifugal pump for fault diagnosis". *Comadem 2014*, Brisbane, Australia.
- [19] Abusaad, S., Benghozzi, A., Shao, Y., Gu, Fengshou and Ball, A., 2013. "Utilizing Data from a Sensorless AC Variable Speed Drive for Detecting Mechanical Misalignments". *Key Engineering Materials*, 569. pp. 465-472. ISSN 1013-9826.
- [20] Johnsen, E. and Ronningsen P. (2003) "Viscosity of 'live' water-in-crude-oil emulsions: experimental work and validation of correlations". *Journal of Petroleum Science and Engineering* 38 , pp. 23– 36