



# University of HUDDERSFIELD

## University of Huddersfield Repository

Ghabar, Omar

AN INVESTIGATION INTO CONTEXT-AWARE AUTOMATED SERVICE IN SMART HOME FACILITIES: SEARCH ENGINE AND MACHINE LEARNING WITH SMARTPHONE

### Original Citation

Ghabar, Omar (2018) AN INVESTIGATION INTO CONTEXT-AWARE AUTOMATED SERVICE IN SMART HOME FACILITIES: SEARCH ENGINE AND MACHINE LEARNING WITH SMARTPHONE. Doctoral thesis, University of Huddersfield.

This version is available at <http://eprints.hud.ac.uk/id/eprint/34785/>

The University Repository is a digital collection of the research output of the University, available on Open Access. Copyright and Moral Rights for the items on this site are retained by the individual author and/or other copyright owners. Users may access full items free of charge; copies of full text items generally can be reproduced, displayed or performed and given to third parties in any format or medium for personal research or study, educational or not-for-profit purposes without prior permission or charge, provided:

- The authors, title and full bibliographic details is credited in any copy;
- A hyperlink and/or URL is included for the original metadata page; and
- The content is not changed in any way.

For more information, including our policy and submission procedure, please contact the Repository Team at: [E.mailbox@hud.ac.uk](mailto:E.mailbox@hud.ac.uk).

<http://eprints.hud.ac.uk/>

**AN INVESTIGATION INTO CONTEXT-AWARE AUTOMATED  
SERVICE IN SMART HOME FACILITIES: SEARCH ENGINE AND  
MACHINE LEARNING WITH SMARTPHONE**

**By**

**OMAR GHABAR**

A thesis submitted to the University of Huddersfield in partial fulfilment of the  
requirements for the degree of Doctor of Philosophy

In the School of Computing and Engineering  
Department of Informatics

Queensgate, Huddersfield, United Kingdom.

(September, 2017)

©Omar Sulayman Omar Ghabar, 2017

## **ABSTRACT**

Technological advances, in general, coupled with the widespread use of smartphones, create ever more opportunities for mobile applications. This thesis considers the use of such devices within embedded systems to provide automated services in smart home automation. The overall approach links together context-aware data from the physical environment, sensors and actuators for domestic appliances and statistics-based decision-making. A prototype system named ‘Wireless Sensor/Actuator Mobile Computing in the Smart Home’ (WiSAMCinSH) is developed, which in turns aims to provide services that can benefit clients who are currently dependent on others in their daily activities.

This research highlights and covers the following concepts. Firstly, it addresses the need to improve the prototypical decision-making model by enabling it to take into account context-aware information as conditions under which particular action decisions are appropriate. Secondly, an essential aspect of context-aware performance architecture is that its features must be of high accuracy, explicitly readable and fast. Thirdly, it is necessary to determine which probability-based rules are most effective in generating the dynamic environment to control the home facilities. Finally, it is important to analyse and classify in depth the accuracy of context acquisition and the corresponding context control using cross-validation methods.

A case study uses integrated mobile detection technology to improve the efficiency of mobile applications, taking into account the resource limitations forced on the use of mobile devices. It also utilises other embedded sensing technologies to predict expectations, thereby enabling automatic control of facilities in the home. The main approach is to combine search engines and machine learning to create a system architecture for a context-aware computing service. Among the major challenges are finding the best statistics-based rules for decision-making and overcoming the heterogeneous character of the many devices which are used together. The results achieved show very promising potential for the use of mobile applications within a context-aware computing service, albeit one which still presents problems to be resolved through future research.

**Keywords:** Smart home, Smartphone, Embedded sensors, automated service, Context-aware and Statistical-based rules

## List of Publications

- [1] Ghabar, Omar., and Lu, Joan. (2017). Smart Home Automation: Context-aware Personalised Service via Statistical-Based Rules. 07-Apr-2018 Recommendation: Author Should Prepare a Major Revision for A Second Review. *Submitted to IEEE Transactions on Mobile Computing*.
- [2] Ghabar, Omar and Lu, Joan (2015). Remote Control and Monitoring of Smart Home Facilities Via Smartphone. In Proceedings of the Fifth International Conference on Advanced Communication and Computation. INFOCOMP (2104) IARIA, Brussels, Belgium, pp. 66-73. ISBN 978-1-61208-416-9.
- [3] Ghabar, Omar and Lu, Joan (2014). "The Designing and Implementation of a Smart Home System with Wireless Sensor/Actuator and Smartphone". In Proceedings of the Fourth International Conference on Advanced Communications and Computation. INFOCOMP (2014). IARIA, Paris. France, pp. 56-64. ISBN 978-1-61208-365-0.

## List of abbreviations

Abbreviation	Full Expression
ADC	Analogue to Digital Converter
ADL	Activity of Daily Living
AmI	Ambient Intelligent
ANN	Artificial Neural Network
BN	Bayesian Network
CA	Context-Aware
CACS	Context-Aware Computrised Service
CF	Context Frequency
CPUs	Computer Processing Units
DAC	Digital-To-Analog Converter
DT	Decision Tree
EF	Event Frequency
GSM	Global System for Mobile Communications
HMM	Hidden Markov Model
HCI	Human Computer Interaction
ICF	Inverse Context Frequency
IR	Information Retrieval
K-NN	K-Nearest Neighbour
MAP	Maximum a Posteriori
MCU	Micro Controller Unit
ML	Machine Learning
MLN	Markov Logic Network
M2M	Mobile to Machine
NBDM	Naive Bayesian Decision Making
NBC	Naive Bayesian Classifier
PC	Personal Computer
RFID	Radio Frequency Identification
ROC	Receiver Operating Characteristic

SI	Smart Intervention
SVM	Support Vector Machine
TF-IDF	Term Frequency and Inverse Document Frequency
UART	Universal Asynchronous Receiver Transmitter
WiSAMCinSM	Wireless Sensor Actuator Mobile Computing in Smart Home
WAP	Wireless Access Point
WSN	Wireless Sensor Network
WSAN	Wireless Sensor Actuator Network
XML	Extensible Markup Language

## **Acknowledgements**

First praise is to Allah, the Almighty for the blessing and mercy that had been given to us, health and inspirations during our study. I would like to thank, with foremost sincere appreciation and gratitude to my supervisor Professor Joan Lu for her unwavering guidance, support, advice, encouragement, and for continuous suggestions throughout my PhD study.

I am highly grateful to my wife Aber Aboalgasm for providing such indispensable support and guidance, as well as her co-operation and encouragement, without which I would not have been able to complete the thesis.

I am very much thankful, with sincere feelings and the strongest kind words from my heart, my gratitude to my parents, my brothers, my sister, my nephews, and my nieces for their supporting and immeasurable sacrifices to continuation and completion of the research journey. I here acknowledge in particular the support and influence of my late father, Sulayman Ghabar. I would also like to thank the study skills tutor in the School of Computing and Engineering, Hugh Peters.

In the second place, I would like to express my respect and special gratitude to our best friends to Mrs Julia and her husband and Dr Zhaozong Meng for their progressiveness and inspiration in making such a pleasant research environment.

I would especially like to thank all staff department of informatics at the Huddersfield University for being so willing to help in the successful completing my PhD thesis.

To relative, friends and others who in one way or another shared their support, financially and physically, thank you.



## **Statement of Originality**

I hereby certify that all of the work described within this thesis is the original work of the author. Any published (or unpublished) ideas and/or techniques from the work of others are fully acknowledged in accordance with the standard referencing practices.

(Omar Ghabar)

(September, 2017)

## Table of Contents

ABSTRACT.....	ii
Acknowledgements.....	vii
Statement of Originality.....	viii
Table of Contents.....	ix
Chapter 1 Introduction.....	1
1.1 Introduction.....	1
1.2 The appliances, wireless network, platforms and methods.....	3
1.2.1 The devices and wireless communication networks.....	3
1.2.2 Context-aware computing service platforms.....	4
1.3 Research Problem.....	5
1.4 Significance of the Study.....	7
1.5 Research Aim and Objectives.....	7
1.6 Research Approach and Clarification.....	9
1.7 Contribution of the Research.....	10
1.8 Design Science Research Framework (DSRF).....	12
1.9 Thesis Structure.....	14
Chapter 2 Literature Review.....	17
2.1 Introduction.....	17
2.2 Context-Aware Model in the Smart Home.....	18
2.3 System Architecture for Context-Aware Built-in Smart Home Applications.....	21
2.4 Wireless Technologies and Smartphone Remote Control.....	26
2.5 Activity and Monitoring Based on Context-Aware Services.....	28
2.6 Potential Models for Monitoring and Control in the Smart Home.....	31
2.6.1 Supporting Technologies.....	34
2.7 Probability-Based Methods and Applications.....	35
2.7.1 Description of the Statistical Rule for Search Engine utilized by TF-IDF.....	36
2.7.2 Naïve Bayesian Decision Making.....	39
2.8 Hybrid Intelligent System.....	42

2.9 Decision Making Utilising Machine Learning Probability Methods .....	45
2.9.1 Context-aware Abstract Method.....	46
2.9.2 Bayesian and Naive Bayesian theories as dependent and independent conditional .....	46
2.9.3 Hidden Markov Method .....	50
2.9.4 Support Vector Machines .....	51
2.9.5 Decision Tree.....	52
2.10 Machine Learning Using Weka Tool .....	58
2.11 The Smart Home Growth Rate and Challenges for an Ageing Population.....	60
2.12 The Concepts of Home Automation.....	62
2.13 Problems Identified .....	63
2.14 Summary .....	64
Chapter 3 The Design of the System Architectures.....	66
3.1 Architecture Design for General Prototype Model .....	66
3.1.1 Design of sensors.....	68
3.1.2 Obstacle avoidance sensor.....	69
3.1.3 Ultrasonic distance measurement sensor .....	70
3.1.4 Light sensor .....	71
3.1.5 Temperature sensor.....	71
3.1.6 Human body sensor .....	72
3.1.7 Smoke sensor.....	72
3.1.8 Humidity sensor.....	72
3.1.9 Sound sensor.....	73
3.2 Relay (actuator) function.....	73
3.3 Microcontroller unit (logic converter).....	75
3.3.1 Embedded system connection with devices .....	76
3.4 Wi-Fly wireless transceiver adapter (RN-370) .....	76
3.4.1 The Wi-Fly serial adapter (RN370).....	77
3.5 Smartphones and PCs (end users).....	77

3.6 Design of the General Prototype System .....	78
3.6.1 Context-aware smart home automation prototype.....	78
3.6.2 Physical layer.....	79
3.6.3 Communication layer .....	80
3.6.4 Wireless connection of actuators and sensors .....	80
3.6.5 Topologies network configuration.....	83
3.6.6 Context data processing layer.....	84
3.6.7 Modelling and processing context-aware data .....	85
3.6.8 Database service layer .....	87
3.6.8.1 Database and its schema .....	87
3.6.9 Context-aware modelling .....	90
3.6.10 Statistical and decision-making layer .....	91
3.6.11 Interaction of Machine Learning Uses .....	91
3.6.12 SHS Context-aware Automation and Decision Support.....	91
3.7 Summary .....	92
Chapter 4 Experimental Configuration and Results .....	94
4.1 Introduction .....	94
4.2 Experimental data collection and process .....	94
4.2.1 Setup and configuration the system by user .....	98
4.2.2 Setup configuration through serial port tester RS232: .....	100
4.2.3 Setup configuration through Wi-Fly serial adapter using Tera Term: .....	100
4.2.4 Setup configuration through Wi-Fly RN370 using iPhone: .....	101
4.3 Compiler programmer in Keil uVision3 .....	102
4.4 Sensor Testing Results .....	104
4.4.1 Results from the temperature sensos .....	105
4.4.2 Results from the ultrasonic distance measurement sensor .....	108
4.4.3 Results from obstacle and body sensors .....	109
4.4.4 Results from the brightness sensors.....	109
4.5 Distribution of context-aware information in the database.....	112

4.6 Testing and Evaluation of Smartphone Applications.....	113
4.6.1 Mobile application interfaces .....	113
4.6.2 Sensor results using Tera Term and mobile phone.....	114
4.6.3 Monitoring environment.....	115
4.6.4 Device control.....	118
4.6.5 The Concepts of Smartphone Appliances Applications: .....	118
4.7 Summary .....	119
Chapter 5 Statistic-based Rule Computation for Context-Aware Automated Service ...	120
5.1 Context-Aware Abstraction and Incorporation .....	121
5.1.1 Context-Aware Abstraction using the Threshold-based Method .....	122
5.1.2 Context-Aware Information Incorporation Frameworks.....	123
5.1.3 Context-Aware Reasoning from Physical Layer to Decision Layer .....	124
5.2 Context-Aware Computing Service .....	126
5.2.1 Derivation of Context-Aware Item Weights using EF-ICF-IF.....	129
5.2.2 Pseudocode Algorithm for EF-ICF-IF.....	132
5.2.3 Modelling System Performance through Naïve Bayesian Decision Making .	135
5.3 Summary .....	143
Chapter 6 The Smart Home Scenario and Statistical-Based Rules Performance .....	144
6.1 Smart Home Case Study .....	144
6.2 Result of Using EF-ICF-IF in New Term-Weighting Context .....	145
6.2.1 Results of Using Statistics-Based Rules with Context Data.....	147
6.3 Naïve Bayes Decision Making Results .....	149
6.3.1 Probability of each attribute .....	149
6.3.2 Conditionally independent probability .....	150
6.3.3 Maximum Likelihood.....	151
6.4 Weka Confusion Matrix (Error Matrix) Results .....	154
6.5 Training set for creating the prediction models .....	157
6.5.1 The condition system to test the trained models.....	158
6.5.2 Rule Matching between actual condition and prediction condition .....	160

6.5.3 Experimental Results of Naïve Bayes Decision Making using Weka Tool...	163
6.5.3.1 10-fold cross-validation .....	164
6.5.3.2 Holdout method using Naïve Bayes .....	166
6.5.3.3 Visualisation of threshold ROC curve .....	167
6.6 Summary .....	173
Chapter 7 Evaluation and Discussion .....	174
7.1 Evaluation of Naive Bayesian Decision Making Method.....	174
7.2 Comparison of the Context-aware Class Action.....	180
7.2.1 Class Action Accuracy .....	180
7.3 Comparison of the Context-aware Class Action Results Using Weka .....	182
7.4 Discussion Using Decision-Making Automation and Cross-validation .....	184
7.5 Discussion Using Cross-Validation Methods .....	186
7.6 Limitations and Open Subjects .....	188
7.7 Summary .....	189
Chapter 8 Conclusions and Future Work.....	190
8.1 Conclusion.....	190
8.2 Learning Skills .....	196
8.2.1 Devices and Wireless Communication Networks .....	196
8.2.2 Context-Aware Computing Service Platforms .....	198
8.2.3 Basic Rules and Methods .....	198
8.3 Future Work .....	201
References.....	203
Appendix A.....	221
Appendix B.....	230
Appendix C.....	234
Appendix D.....	238

## List of Figures

Figure 1-1 Design science research process model and thesis framework (Kuechler & Vaishnavi, 2008).....	12
Figure 1-2 Thesis Outline .....	14
Figure 2-1: Model linking smart home appliances to user needs (Mann & Milton, 2005) .....	25
Figure 2-2 Relation between connections: (a) Pipeline, (b) Converging and (c) Diverging (Babakura et al., 2014).....	48
Figure 2-3: Bayesian model (Song & Cho, 2013) .....	50
Figure 2-4: Basic graphical model illustration of conditional independence of HMM (Brand, Oliver, & Pentland, 1997).....	51
Figure 2-5 SVM classifiers of optimal margin and hyperplane of two classes .....	52
Figure 3-1 Framework layers in the WiSAMCinSH system .....	67
Figure 3-2 Sensor pins connected to GND, OUTPUT and VCC .....	68
Figure 3-3 Smart home sensors design .....	69
Figure 3-4 Obstacle avoidance sensor output signal.....	69
Figure 3-5 Time diagram for ultrasonic distance measurement sensor (ElecFreaks, 2014b) .....	70
Figure 3-6 Measurement angle and performance within 30 degrees (Kuantama, Setyawan, & Darma, 2012) .....	70
Figure 3-7 (a) Time diagram for VCC and VDI voltage supply; (b) Luminance measurement results.....	71
Figure 3-8 Temperature sensor DS18B20 output signal.....	71
Figure 3-9 Human body detection sensor output data .....	72
Figure 3-10 Humidity detection sensor output data.....	73
Figure 3-11 Relay (RSD-O5VDC-SL-C) .....	74
Figure 3-12 Microcontroller unit STC89C52RC .....	75
Figure 3-13 Overview of the Wi-Fly RN-370 adapter configuration .....	76

Figure 3-14 End-user connection between Wi-Fly and iPhone 4.....	78
Figure 3-15 Comprehensive plan of the system architecture in a automated smart home service .....	79
Figure 3-16 Wireless Network Communication of Smart Home Model.....	82
Figure 3-17 Wireless communications over ad-hoc and infrastructure networks .....	84
Figure 3-18 Context-aware processing data .....	86
Figure 3-19 Database structure and schema design.....	88
Figure 3-20 Context-aware model .....	90
Figure 4-1 The MCU, Wi-Fly RN-370 and four relays connected with LED lights and fans.....	96
Figure 4-2 The MCU, Wi-Fly RN-370 and eight sensors connection.....	97
Figure 4-3 Experiment platforms in the laboratory .....	98
Figure 4-4 shows how to set up serial port tester RS232.....	100
Figure 4-5 Connection setup with Wi-Fly (RC370).....	101
Figure 4-6 shows the setup of an iPhone with Wi-Fly-GSX-a5 .....	102
Figure 4-7 shows the software Keil uVision3 and STC-ISP.exe.....	103
Figure 4-8 Reading of sensor data for wireless methods.....	104
Figure 4-9 First day evaluation of temperature by sensor DS18B20 and TermPro-TP-60 .....	106
Figure 4-10 Second day evaluation of temperature by sensor DS18B20 and TermPro-TP-60.....	106
Figure 4-11 Third day evaluation of temperature by sensor DS18B20 and TermPro-TP-60 .....	107
Figure 4-12 shows the ultrasonic measuring sensor; the dashed line is the real measured value.....	108
Figure 4-13 illustrates the results of three digital sensors.....	109
Figure 4-14 Comparison of first day's results for light intensity during daytime, with and without light.....	110



Figure 4-15 Comparison of second day’s results for light intensity during daytime with and without light .....	111
Figure 4-16 Comparison of third day’s results for light intensity during daytime with light ON/OFF .....	111
Figure 4-17 Smartphone (iOS) application interface for smart home design .....	114
Figure 4-18 Time spent using touch screen to monitor environment .....	117
Figure 4-19 Average time spent using touch screen to monitor environment .....	117
Figure 5-1 Context incorporation framework .....	124
Figure 5-2 Basic plan of context-aware reasoning .....	125
Figure 5-3 High-level classification of context data .....	126
Figure 5-4 Comprehensive model of multiple contextual services attributes for enhanced Naïve Bayes decision making .....	129
Figure 5-5 Naïve Bayes architecture model .....	135
Figure 5-6 Construction of Naïve Bayesian decision making .....	137
Figure 6-1 Results of computation using EF-ICF-IF method .....	146
Figure 6-2 Relationship between total weights and ranking value .....	147
Figure 6-3 Results of weighting context-aware terms using statistics-based rules .....	149
Figure 6-4 Action probability for window and fan .....	150
Figure 6-5 Results of conditionally independent probability for four actions .....	151
Figure 7-1 Time complexity of Naive Bayes rules on iMac with Apache/MySQL/PHP177	
Figure 7-2 Time complexity of Naive Bayes rules on iMac with Apache/MySQL/PHP177	
Figure 7-3 Time complexity of Naïve Bayes rules on remote Core i5 .....	178
Figure 7-4 Time complexity of Naïve Bayes rules on Core i5 .....	179
Figure 7-5 Evaluation of accuracy from database history using 10-fold cross-validation .....	181
Figure 7-6 Evaluation of accuracy from database history using holdout method .....	182
Figure 7-7 Evaluation of ROC area from database history using 10-fold cross-validation .....	183
Figure 7-8 Evaluation of ROC area from database history using holdout method .....	184

## List of Tables

Table 1-1 Design science research steps of this thesis .....	13
Table 2-1 summarises and distinguishes earlier and more recent definitions of context from the literature review(G. Chen & Kotz, 2000; Dey, 2001).....	20
Table 2-2 Features of wireless technology .....	28
Table 2-3 Context-aware Algorithms and Devices Investigated .....	54
Table 3-1 Relay specifications.....	74
Table 3-2 Electronic appliance engagement (Ghabar & Lu, 2015).....	81
Table 3-3 Database history .....	89
Table 4-1 Shows the default value between iPhone and Wi-Fly (RN370).....	102
Table 4-2 Records of Database history Context and Approved service .....	113
Table 4-3 Test and expected results (Ghabar & Lu, 2014).....	115
Table 4-4 Test results for home automation (Ghabar & Lu, 2015) .....	118
Table 5-1 shows the database history as page and documents .....	134
Table 6-1 Confusion matrix .....	155
Table 6-2 Calculation of $TN_{wo}$ .....	157
Table 6-3 Rules (Actual Conditions and Decisions Attributes).....	159
Table 6-4 Sample output for both actual and predicted class actions.....	163
Table 6-5 Confusion matrix in smart home decision making.....	165
Table 6-6 Detailed accuracy by class using 10-fold.....	165
Table 6-7 Detailed accuracy by class.....	166
Table 6-8 Evaluation of accuracy of Naïve Bayesian use of database history .....	167
Table 7-1 Time consumption for dynamic, real-time smart home facilities using iMAC .....	175
Table 7-2 Time consumption for dynamic, real-time smart home facilities using Core i5 .....	176

## **Chapter 1 Introduction**

### **1.1 Introduction**

New technologies in sensor and mobile appliances, in connection with embedded systems and communication adapters, have encouraged researchers to consider how such technologies can be successfully used to support the efficiency, fast time execution, accuracy and ease of use of different context-aware computing services. These developments have also promoted the evaluation of context-aware computing services that take advantage of different sensor technologies to provide an automated service based on data from the context environment.

Attempts to develop a smart home system which combines a statistical method with wireless sensor and actuator technologies, an embedded system and pervasive information have led researchers to experiment with a range of heterogeneous service providers (Crepaldi et al., 2015). This approach to managing an intelligent building has the possibility of being both cost-effective and capable of providing a much-appreciated service for this area of home automation. Most of the studies referred to here have made use of an enormous variety of approaches, utilising different sensor technologies and methods to create a smart home service (Alam, Reaz, & Ali, 2012a; Meng & Lu, 2015). Some of the important projects that have been undertaken to improve the design and implementation of smart home automation, as well as their associated challenges, are explored in this section.

In this study, service automation in the smart home is investigated as an architecture model, employing enhanced new techniques and context-aware computing services to assist elderly people and those who suffer from disability or live alone. This is achieved by providing intelligent networks which are designed for remotely controlling and monitoring home facilities using a smartphone. The combination of smartphone technology with a context-aware automated service, using embedded sensors, a search engine and machine learning, can enable aging individuals to live in safety and within a comfortable environment. The smart home is a rapidly growing area of research and a looming opportunity in commerce. Home automation ideas have been utilised in an enormous range

## Introduction

of applications, such as healthcare, medical services, and social and environmental contexts. An inclusive definition of the 'smart home' permits varied applications as well as differences to exist. In essence, it refers to an intelligent building, designed for comfortable living, which contains various technologies and methods to make appropriate decisions. Thus, by adopting a loose definition of smart home features, healthcare and business organisations have been extremely inventive in investing in this idea to meet their different requirements (Crandall & Cook, 2013).

In the living environment, any type of decision-making system or computing service can be considered as automatic machine control. Many appliances or home facilities, such as LED lights, fans, windows, air-conditioning, curtains and TV, are all possibilities for management by a home computerisation service. All these facilities can be directly handled or managed without user interaction. In addition, all information retrieved from the home environment can be utilised as part of a context-aware service to make suitable decisions which reflect the residents' behaviour.

The designer should take into account a specific objective when attempting to design a prototype smart home system. It is especially important to consider the residents' activities and behaviours, and to carefully select appropriate technologies in terms of sensor/actuator devices, wireless adapter, embedded system and context-aware computing service methods. In any smart home application, the researcher should focus on reconstruction techniques and low-cost equipment, particularly when the goal is to help enable older adults to live longer in their own house (Saizmaa & Kim, 2008; Sanchez & Tercero, 2010). There are a number of factors which are assisting the trend towards acceleration in decision-making automation and its applications, such as developments in workstation speed, more rapid and better-quality memory storage techniques, improved low-cost sensors, relays, wireless adapters and embedded systems, in addition to the wide availability of the internet network (Cook & Das, 2007). Moreover, the smart home can be explored through the integration of communication technologies, automated physical services, software and home facilities; these all enable the study of residents in order to provide localised monitoring and control through the input of context-aware sensing data.

## Introduction

Since context-aware computing services with mobile applications are not yet at a fully formed phase, it is an encouraging field in which to make progress with regard to the development and performance of a context-aware personalised service. Low cost technologies and sensors within the embedded system offer good opportunities for the utilisation of mobile devices in context-aware automated services, especially in the area of smart home automation to support elderly residents in their everyday activities. However, it is also important to explore the key limitations in this field, as well as to provide solutions to enable the efficient use of context information and offer a suitable computing service.

### **1.2 The appliances, wireless network, platforms and methods**

The various technologies, platforms and devices used to produce an entire smart-home computing environment are summarised in this section, as they are known in the present field of research (Meng & Lu, 2015). The tools or devices include sensors, an embedded controller, a wireless transceiver and a mobile device offering a mobile operating system. The wireless infrastructure required for the sensors to function, and for the user to manage them, is described, along with the service platform which provides the entire context-aware service.

#### **1.2.1 The devices and wireless communication networks**

##### **1- Actuators and sensors technologies**

Actuators and sensors are the electrical devices which collect the context data. Sensors gather information on the physical circumstances, such as the level of light, temperature, smoke, humidity, noise and weather. Mobile devices also contain some built-in sensors, including a camera, microphone, accelerometer and ambient light sensor.

##### **2- The MCU controller**

The MCU collects the data from the sensors and sends it to the wireless network through the wireless transceiver's Digital Signal Processor (MCUDSP) and Advanced RISC Machine (ARM), which are examples of embedded controllers. These tools can also process new context data to some extent, to improve its quality.

### **3- Wireless communication adapter (Wi-Fly RN-370M)**

Wi-Fly allows communication interfaces to be embedded into the context-aware system by changing the signal from one form to another. The Wi-Fly RN-370M changes the RS-232 serial signal into a Wi-Fly signal; this allows the low-layer electronics to be connected to the Wi-Fi network (EZX, 2011). In the same way, the RN-370M is used to feed the RC232 serial data into the Bluetooth network (Network, 2011).

### **4- Smartphone appliances**

Smartphone devices are extremely important components of the smart-home computer system, they can be utilised to provide an interface between the computer system and the user, they can be used to discover the personal context and individual habits of each user (Bin Abdullah, Negara, Sayeed, Choi, & Muthu, 2012). Current research uses the most up-to-date smartphones with cameras, full touchscreens and internet connection.

### **5- Wireless connection with Ad-hoc and Infrastructure Networks**

The most important aspects of any proposed smart-home computing system are the purpose of use and the practicalities of use. In order to successfully address these, the system must be integrated into the lives of the users in the simplest and least noticeable way possible. This also involves economy and practical convenience. In this study, a wireless environment appeared to be the best way to achieve this; the Wi-Fi and 3G wireless systems have widely available public infrastructures already in place. Wi-Fi is a system suitable for home and office use, while 3G is designed for exterior as well as interior use. These wireless networks use TCP/UDP socket connections and an HTTP connection. The smart case study described in this thesis uses both systems to link the devices and to control the home facilities automatically from context data.

#### **1.2.2 Context-aware computing service platforms**

The mobile computing framework suggested here uses a context-aware service for the client. All context data is collected and stored in the database, and the service is provided by a machine learning technique which uses the resources of the context history and supervised human or automatic interaction with the system. To help in the creation of a context-aware system architecture, a model is developed. The purpose of the model is to

## Introduction

record the connections and functions of the link between the contextual situation, the demands of users and context-aware applications. This model is used to assist in the planning and implementation of the context-aware computing architecture. Both the system model and system architecture are discussed in Chapters 3 and 4.

### 1- **Context modelling and reasoning**

To provide a context-aware service that is satisfactorily adapted to its circumstances, a context model is needed for distribution, computation and provision of the service. The context relating to the mobile platform must be assessed and evaluated with regard to its origin and type. Methods of assessing context-aware environments are discussed later in this study, along with further explanation of the particular model design of this research and its realisation. For example, Chapter 5 discusses the method of context reasoning used to extract high-level information when the sensors have produced only low-level or completely unprocessed data.

### 2- **Creation of rule for high quality machine learning using supervised methods**

A system of service provision which uses machine learning needs the capacity to adapt existing rules or create new ones. In this research, possible rules for carrying out this function are extracted from the pool of use-activities and context data by using mathematical models such as SVM and K-NN. The rules are then used to oversee the context-aware service provision. Naïve Bayes, with Maximum a Posteriori (MAP) probability derived from the context history, is also used and this is dealt with in Chapters 5 and 6. This research uses the tools, methods, theories and models outlined above within a structure of service design, case study and the creation of a prototype system model that provides evidence for assessment and conclusion.

## 1.3 **Research Problem**

From previous studies of smart home monitoring and context-aware control of appliances, the problems that have been investigated can be characterised as follows:

- 1- The cost of the technologies (accessibility)
- 2- The time complexity of the executing facilities (efficiency)
- 3- Feasibility and interoperability.

## Introduction

The accessibility of smart home facilities for elderly people can be defined as “their financial ability to afford the cost of these” (Lê, Nguyen, & Barnett, 2012, p. 611). The problem of the cost of these technologies has been mentioned in many studies, especially in relation to the aging population. Inevitably, the development of new technologies will require specialists in software and various other disciplines to design systems for successful implementation and configuration (Cheek, Nikpour, & Nowlin, 2005; Courtney, Demeris, Rantz, & Skubic, 2008; Lê et al., 2012; Melenhorst, Fisk, Mynatt, & Rogers, 2004). Initially, the smart-home environment can generate high costs when residents need to buy the equipment, set up the network and install smart appliances such as wireless adapters, sensors and remote control systems. For that reason, it is essential that institutions at different levels work together in designing and implementing the home environment for elderly people who cannot meet the costs of such technologies by themselves.

The second problem is that of efficiency within a real-time scenario. The speed at which the system can respond is crucial to its usefulness to the occupant of the smart home. Measuring the proportion of time consumed by the action classifier algorithm is very simple, and this ‘time complexity’ is very strongly linked to the computation power of the machine and the performance of the algorithms (Meng & Lu, 2015). In addition, because the Weka tool may compute and store data in the CPU during the execution of each method, the time taken to test a model through cross-validation is likely to vary according to the power of the platform which is utilised (Guinness, 2015).

There are very few studies offering a complete explanation of the built-in actuator and sensor robotics within a universal context-aware system design, as they include a wide variety of technologies and also require several application situations which might be hard to assess and supply. Specific problems remain present in the theoretical stage, and numerous critical studies still do not offer a clear and extensive description of quality of context (Bellavista, Corradi, Fanelli, & Foschini, 2012). Little previous research and development work has been carried out into aspects of smart home technology, such as to determine the number of users. In addition, most previous research has concentrated on



## Introduction

feasibility studies with regard to the use of interactive communication technologies with context-aware applications (Ding, Cooper, Pasquina, & Fici-Pasquina, 2011).

The prototype system design and implementation outlined in Chapters 3, 4 and 5 attempt to offer a solution to challenges relating to wireless sensor/actuator mobile computing in a smart home. It has therefore been important to design and implement the architecture for the model system's technologies, and to incorporate low-cost sensors and actuator devices to support the occupants' interaction with the physical environment. To achieve this, this study investigates a general context-awareness model, as well as technological solutions that have the capability of sensing, monitoring and remotely controlling smart home automation, thereby dealing with the problem of interoperability.

### 1.4 Significance of the Study

#### 1. Academic significance:

- a) To promote more academic interest in the research and development of smart monitoring systems designed to look after elderly people living within a smart home.
- b) It will also promote understanding of the latest technology and help researchers to realise the significance of the evolving applications of smartphones in relation to monitoring methods for the elderly.

#### 2. Social significance:

- a) The number of elderly and disabled people who live alone is increasing significantly. Therefore, they need additional monitoring by both society and organisations which will benefit from the use of this technology.
- b) With these devices and technologies, the elderly person can become more independent and able to live at home with less direct human assistance.

### 1.5 Research Aim and Objectives

Improvements and developments in new supporting technologies, and the realisation of relevant theoretical algorithms, have encouraged and enabled the practical development of context-aware automated service models designed to reduce user effort. It is therefore important to classify the problems related to this area, and to identify the gaps in

## Introduction

knowledge, in order to make connections between these promising new technologies and the real-world application of a context-aware system.

This research aims to investigate the relationship between theoretical explanation and a practical system, in order to create a comprehensive context-aware model that can incorporate raw context information into a statistics-based rule to provide an effective computing service in a real-world environment. The main purpose of the context-aware architecture model is to decrease resident interaction during the operation of functions through the supervision of machine learning within the computing service. In practice, smartphone appliances are widely available, as is inexpensive sensor technology which can be utilised to provide the context data in the computing function. There are several aspects involved in achieving the aim, which include the design and implementation of a comprehensive prototype system able to efficiently handle the acquisition and retrieval of raw context data. It is therefore important to dealing with requests and updates, querying and ranking, and saving and distributing information. Such a system should be able to provide an appropriate computerised service.

This research differs from many other works that focus on current technologies and real-world applications. It pays more attention to the construction of a comprehensive prototype system using algorithms to provide a context-aware personalised service. This system offers a way to monitor and control electrical devices within a dynamic smart home situation. In order to complete the aim of this thesis, there are some objectives which need to be achieved.

### **The objectives for this research are:**

1. To investigate a model for the context-aware computing service, using the literature review to determine the limitations and challenges such a service may face.
2. To design a general architecture system named Wireless Sensor Actuator Mobile Computing in the Smart Home (WiSAMCinSH) with the goal of providing a multifunctional contribution to assisting elderly people in their daily lives. This research investigates the system through experimental work within the laboratory via wireless technology using a smartphone and Wi-Fly adapter, a Micro Controller

## Introduction

Unit (MCU-STC89C52RC), Wi-Fly-RN370, actuators and eight types of sensors, as well as an iMac and Personal Computer (PC).

3. To develop a prototype for an appropriate new architecture which can gather, pre-process, store and distribute sensor data, and then use these data to proactively support a context-aware personalised service through a MySQL database using PHP and a Remote Apache/MySQL/PHP service on an iMac machine with local host Visual Studio/ C Sharp 2013 (ASP.NET).
4. To take advantage of the context database history to realise potential theory and methods for better supervision of a context-aware computing service.
5. To identify challenges by using a search engine to investigate the application of EF-ICF-IF to weight the context-aware data items.
6. To develop machine learning utilising Naïve Bayesian classification, which will be the basis of an algorithm to perform decision making in the smart home.
7. To invoke the EF-ICF-IF term weightings into Naïve Bayesian decision making, enabling them to work together as a hybrid architecture for providing a smart home service using context-aware information.

### 1.6 Research Approach and Clarification

The main target of this research is to design and implement a model system that solves problems for the occupants by retrieving context-aware information from the database or the environment, using and sending it to their smart phone or directly from smart space to assist human activity at home. This assistance includes home equipment control, activity reminding and environment monitoring. The goal of the prototype system is to determine how to invoke the computation of context-aware data using a dynamic statistics-based rule to create a computing service that will support residents in the activities of daily life. In order to handle problems in the smart home situation, the system architecture also needs to have the ability to process and learn from uncertain data within the context history database.

Smart homes served by sensors, actuators and other technology will assist elderly people to live in a safe and secure environment. By monitoring and observing the aged population

## Introduction

and continually acquiring data for normal and abnormal situations, the costs of providing rapid support can be reduced and efficiency improved within social services. To achieve this aim, a system design may be implemented by integrating different sensors/actuators and a control unit with wireless adapters and smartphones. The function of the prototype relies on a set of nominated sensors that take their input from sensing objects. Furthermore, the system should contain some parameters derived from concepts such as usability and user preferences. It is apparent that such a context-aware computing service should be able to deliberate between possible results and improve the achievement of smartphone interfaces by indicating the utiliser and the context's physical condition through the sensors (C. B. Anagnostopoulos, Tsounis, & Hadjiefthymiades, 2007). To date, the basic limitations have been the lack of general context-aware automation, the heterogeneity of procedures, limits in computerisation ability and confidentiality concerns (Carreras et al., 2010). Therefore, in this research, the approaches to collecting and using raw context data, the automation for context data transfer and the statistics-based rule for the computing service will be explored, with the goal of producing a general model for a context-aware computing service.

### 1.7 Contribution of the Research

The research will contribute to the smart home field by developing and using the WiSAMCinSH prototype, which is based on a smartphone integrated with various sensors and a logic converter. The system is intended to implement smart home control at both a basic level, with active sensing, and at a higher level, which also includes home automation dependent on EF-ICF-IF (search engine) and Naïve Bayesian decision making (machine learning). The purpose is to evaluate the concept, design and implementation of the suggested model and algorithms, in order to show where there is great potential. The main contributions of this research can be summed up as follows:

1. The smart home monitoring and control model consists of eight wireless-type sensors that have been designed and developed. The target of the prototype is to offer a safe and comfortable living environment to one particular sector of the

## Introduction

population, namely, elderly people who are living alone. In addition, the system has been designed to utilise actuators to control equipment in the home.

2. The system design was initially based on Wi-Fly-RN370 wireless adapter communication, rather than other wireless technology, because this has the ability to cover up to 300m in an open area, as well as the capability of connecting with iPhones and PCs through ad-hoc or infrastructure networks.
3. A smartphone such as the iPhone is employed in the system for different functions, such as displaying information on the screen and enabling the resident to control appliances in the smart home. The effective retrieval of context sensing data, in terms of both the mobile phone and affordable commercial sensing appliances, are analysed in depth for efficient use of context service.
4. The context-aware system architecture has been designed to handle the representation of context data which is gathered from heterogeneous technologies and which includes raw context information to take benefits for further classification.
5. Context-aware computing services depend on a statistics-based rule for decision making; the system developed here uses ‘maximum likelihood’ to control facilities within the service.

In attempting to apply such proposed developments to a real-world situation, many challenges have been faced, such as the range of different technologies involved, resident movement, and complications of context data modelling with the location of sensors (e.g. as stated above in points 1 and 4). Nevertheless, the scenario of the case study provides good performance results from the investigation of algorithms applied to smart home devices within the context of services for elderly people. This research, therefore, concentrates on the use of search engines and machine learning to integrate the raw context database history, in order to guarantee reduction in time complexity and investigate the efficiency of the computing service.

### 1.8 Design Science Research Framework (DSRF)

A DSRF is defined by Lakatos (1980) and Kuhn and Hawkins (1963) as an “*activity that contributes to the understanding of a phenomenon*”. It has been extensively used in the area of Information Systems (IS) design, which has become a major topic of research in recent years. Researchers believe that the DSRF should include new knowledge or processes (Von Alan, March, Park, & Ram, 2004), and Kuechler and Vaishnavi (2008) have suggested a framework for design science research methodology, as shown in Figure 1-1.

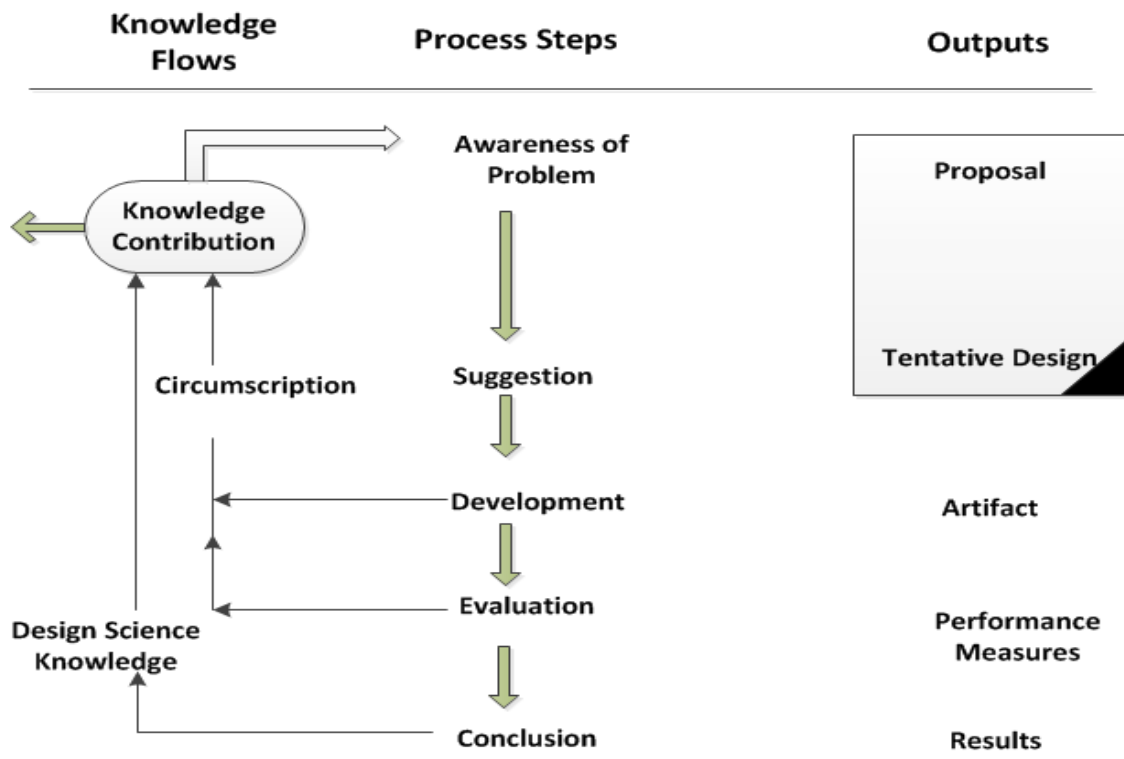

Figure 1-1 Design science research process model and thesis framework (Kuechler & Vaishnavi, 2008)

This thesis is grounded on the above model in order to focus on the field of interest and challenges arising from various aspects, including the development of new electronic engineering devices and information retrieval methods. The fundamental goal of DSR is to find solutions to methodological problems, using the study and assessment of artefacts as a basis for the research structure (Von Alan et al., 2004). This approach is appropriate for

## Introduction

meeting the aim and objectives of this research, and therefore the structure is based on DSRF methodology as illustrated in Table 1-1.

Table 1-1 Design science research steps of this thesis

Chapter Number	Design Science Research Stages	Stages in the Thesis
<b>Chapter 2: Literature review</b>	Awareness of problem	Issues in the research field are recognised and problems in related studies are described.
<b>Chapter 1: Aim, objectives, technologies and method</b>	Suggestion	The aim and objectives of the research are outlined.
<b>Chapter 3: Prototype system design</b>  <b>Chapter 4: Experimental setup and initial results</b>  <b>Chapter 5: Context-aware personalised computation service</b>  <b>Chapter 6: Case study and method results</b>	Development	Suitable technologies, including their application interfaces, are selected to implement the suggested prototype design model. The implementation of the comprehensive system architecture and the functions of each level are described. The experimental configuration and setup are tested and initial results of the model explained. Implementation using mathematical approaches and appropriate attributes are described.
<b>Chapter 7: Evaluation and discussion</b>	Evaluation	Evaluation and discussion are carried out using both quantitative and qualitative approaches.
<b>Chapter 8: Thesis conclusion</b>	Conclusion	Description of the issues, suggestion, development and evaluation are integrated to justify the results and contribution of the research.

According to the design science research framework, the first step is to develop a full awareness of the research question through detailed consideration and discussion of previous studies. Following that, the aim, objectives and research problems are defined. The next task is the system design and implementation, which is linked with the application of technologies to achieve the purpose of the research. Next, the results of the system

## Introduction

architecture design are evaluated and discussed in relation to the methodology adopted. The final step is the conclusion, and suggestions for further research are made based on the outcome, design, implementation and contribution of the study.

### 1.9 Thesis Structure

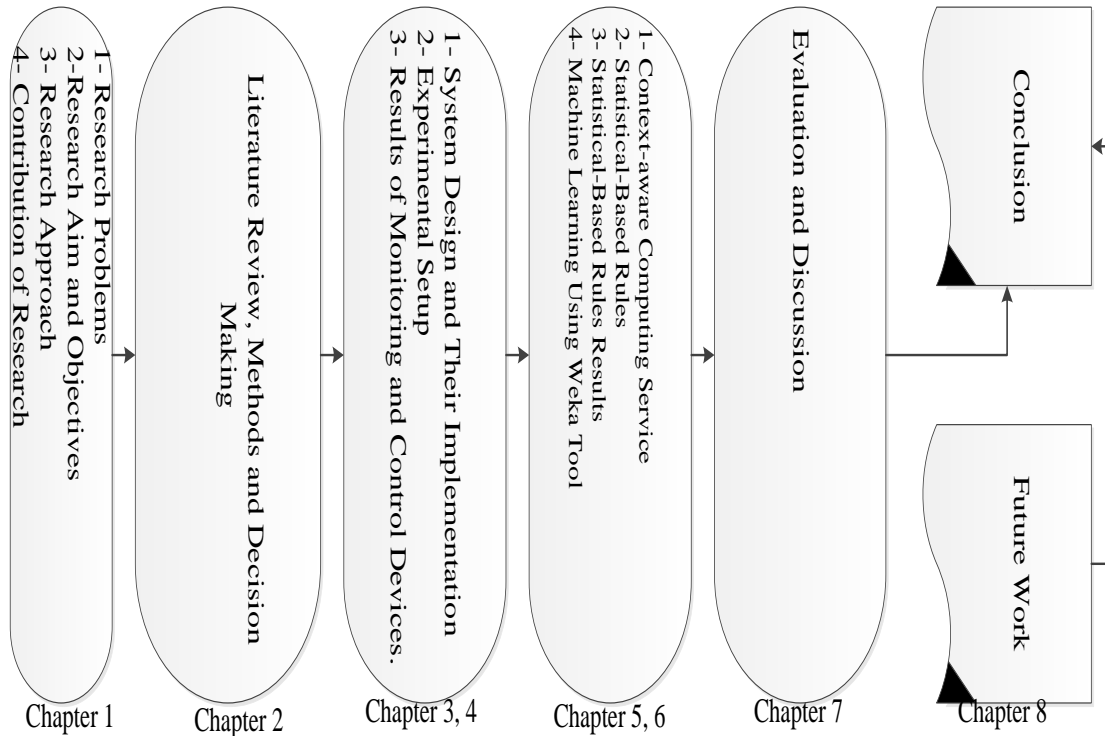

Figure 1-2 Thesis Outline

The research is broken down into the following eight chapters, exclusive of the abstract.

Chapter 1 consists of the introduction, background information about the elderly population growth rate, definitions of context-aware and mobile context-aware attributes, and an introduction to the statistics-based rule system including a search engine and the Bayes network. There follows a discussion of the problems of this study, the aims and objectives of this research and an explanation of the research's contribution to knowledge. The first chapter ends with a summary of the thesis structure.

Chapter 2 provides a review of relevant literature about system architecture for built-in context-aware smart home applications, and introduces a case study about an elderly



## Introduction

woman in relation to the context-aware automated service. It considers the application of probability-based methods and describes the significance of using a statistics-based rule for dealing with context-aware information using TF-IDF and Naïve Bayesian classification. It summarises the monitoring of activity-based context-aware information and provides details about current research into applications management in the smart home. It also provides an overview concerning the various different methods and algorithms utilised in smart home applications. The last two points introduce the challenges of caring for an elderly adult and the potential benefits of the concept of smart home facilities.

Chapter 3 is divided into three main sections. The first section presents the low-level design and implementation of the prototype system equipment, such as sensors, actuators, the MCU, Wi-Fly wireless network and smartphone, as well as their functions. The second section describes the five layers in the general system architecture including details about each level. Finally, the modelling and processing of context-aware information using the MySQL database are implemented.

Chapter 4 refers to the experimental procedure for WiSAMCinSH by focusing on the results of gathering information from a selection of sensors and their accuracy. It also includes the results and evaluation of applications for both monitoring and controlling the home environment and facilities using a smartphone device.

Chapter 5 offers extensive detail about the current study's research into possible statistics-based rules to deal with context-aware information and smart home automation. This chapter describes the main rules that could be used in the high-level architecture, such as the Smart Intervention method, the EF-ICF-IF term weight algorithm, and the Naïve Bayesian context-aware home automation algorithm. In addition, pseudo-code algorithms are designed for each method.

Chapter 6 explores the results and analysis of the performance of the statistics-based rules within practical work, and provides the results of context-aware term weighting using the EF-ICF-IF and Naïve Bayesian methods. It also includes the results of cross-validation with the WEKA tool, employing both 10-fold and holdout methods.

## Introduction

Chapter 7 incorporates research discussion and evaluation by comparing the results of different methods in an investigation of the most accurate performance of class actions. It also includes a discussion of practical work using the Naïve Bayes decision-making rule as well as the Weka tool.

Chapter 8 includes two sections. The first section concludes the study by describing the investigation and some drawbacks of the research. The second section contains suggestions for further work, including ideas and recommendations regarding the possibility of using the framework in future research.

## Chapter 2 Literature Review

### 2.1 Introduction

The use of context-aware information has become an important issue in different areas of research, especially in relation to smart home automation and mobile computing. For example, low-power sensors are now a significant technology in the retrieval of context-aware data from the smart environment. In addition, technologies such as communication adapters, smartphones, embedded systems and actuators can provide a better quality of smart home control system to address the present and future needs of residents in remaining independent and having a good quality of life (Davidovic & Labus, 2015).

In 2002, Gellersen and his colleagues conducted a study of the physical context by extracting data from the various kinds of mobile and computer applications found within the smart home setting (Gellersen, Schmidt, & Beigl, 2002). In the next decade, however, the greatest effect of mobile computing services is likely to be the output of context-aware interaction with the activity of human environments. The aim of the smart home is to anticipate the needs of the user, and to do so actively by calculating information regarding the user's context and that of the home environment in order to provide suitable services. For that reason, in 2009, Van Nguyen et al. believed that the context-aware model would be the most significant strategy in the ubiquitous computing used for smart home requirements (Van Nguyen, Woo, & Choi, 2009). Alam et al. subsequently reviewed collective information on various technologies used in the smart home, and defined the smart home (SH) as “*an application of ubiquitous computing that is able to provide user context-aware automated or assistive service in the form of ambient intelligence, remote home control, or home automation*” (Alam, Reaz, & Ali, 2012b, p. 1191). In the smart home setting it is also very important to make available context-aware applications which can assist older people to be more comfortable.

There are at present numerous designs of smart home applications. Most of the prototype system designs utilise wireless adapter techniques for network communication between home devices and the microcomputer unit (Sriskanthan, Tan, & Karande, 2002). The

## Literature Review

essential difficulty is that residents can find new technologies frustrating, so there are issues which must be addressed in the design process to make it easier for the smart home dweller to systematise the routine activities of daily life (M. Li & Lin, 2015). For instance, it should be simpler to regulate the building's light and temperature so that the household has sufficient brightness and correct temperature in a very short time. The principal approach to dealing with these problems must be to develop the smart home environment based on various technologies (Xiao & Boutaba, 2013).

To succeed in this aim, it is necessary to incorporate various advances in technology into the smart home prototype system, such as internal wireless networks, intelligent control and home automation (Robles & Kim, 2010; Teymourzadeh, Ahmed, Chan, & Hoong, 2013). This chapter describes work related to research which has been conducted in the area of context-aware computing services, wireless sensors and actuators in the smart home. It includes details of smart home applications and previous studies of algorithms related to the following aspects:

- 1- The context-aware model in the smart home.
- 2- System architecture for context-aware built-in smart home applications.
- 3- Activity and monitoring based on context-aware services.
- 4- Potential models for monitoring and control in the smart home.
- 5- Probability-based application methods.
- 6- Decision-making utilising machine learning probability methods.
- 7- Machine learning using Weka tools.
- 8- The smart home challenges for an ageing population.
- 9- The main concepts in smart home automation.
- 10- Problems identified.

### **2.2 Context-Aware Model in the Smart Home**

Context-awareness has appeared in many studies which have measured different types of heterogeneous situation; these studies have provided the researcher with historical information and enabled an assessment of the issues. The exploration of context-aware information, and adaptation of methods to create a universal approach, poses significant

## Literature Review

challenges. It involves the investigation of Context-Aware (CA) concepts from computing services, such as pervasive, ubiquitous computer, smartphone and wireless sensor techniques, as well as possibly trying to discover the range of information provided from low-level to high-level perspectives. The concept of context-awareness has been mentioned and superficially discussed in several studies of information retrieval since the 1960s. Such studies have sought to develop knowledge of the extent to which Computer Processing Units (CPUs) can sense raw data, respond and may become accustomed to functions determined by information gathered from the smart environment (Makris, Skoutas, & Skianis, 2013). More recently, context-aware models have taken into consideration context data with the purpose of acclimatising their actions to the existing context without explicit user interference.

In 1995, Schilit described a new and convenient synthetic procedure for obtaining context-aware terms in a ubiquitous computing service designed to collect context data which could be used in different applications (Schilit, 1995). For the last two decades, there has been substantial growth in the utilisation of CA methods to share and transmit raw data between remote access and context, as well as a pervasive development of CA models. In respect of this tendency, wireless adapter technologies and smartphones have been adopted as the most capable and stimulating networking tools for the introduction of innovative context-aware methods. Indeed, a considerable number of smartphone computing services and various wireless adapters have been widely investigated with regard to developments in handling context-aware information (Malik, Mahmud, & Javed, 2007).

It is notable that numerous research studies have attempted to provide incomplete definitions of CA in their literature reviews. Various sources in the 1990s defined context-awareness by providing some examples (Schilit, 1995), and some studies also tried to relate it to further concepts, such as location, situation, time and environment (Franklin & Flaschbart, 1998; Hull, Neaves, & Bedford-Roberts, 1997), though with restrictions in terms of range of usability.

Chen and Kotz define CA, as *“any information that can be used to characterize the situation of an entity. An entity is a person, place, or object that is considered relevant to*

## Literature Review

*the interaction between a user and an application, including the user and application themselves*” (Dey, 2001, p. 5). It is also apparent that there are several definitions related to the context of mobile computing as an arrangement of environmental conditions and locations that determine the performance of an object, or of an application where an occurrence or event is attractive to the occupant. These interpretations of context-aware computing are summarised in Table 2.1

Table 2-1 summarises and distinguishes earlier and more recent definitions of context from the literature review(G. Chen & Kotz, 2000; Dey, 2001).

Previous Definitions of Context	Current Definitions of Context
“Context as a set of numerical values”	“Context as measured and inferred knowledge”
“Context as a state of information”	“Context as a flow of information”
“Characterises the situation of an entity”	“Arises from the general activity of the Condition Access System”
“Context as an outcome of interactions”	“Context that exists independently of interactions”
“Users take part in system adaptation procedures”	“System adaptations unnoticed by users”

Clearly, there are some weaknesses in such attempts at definition. Firstly, context-awareness is acquired by gathering information that weights and infers knowledge, rather than just a conventional value without realisation of these results (Strassner & O'Sullivan, 2009). Secondly, there is a clear insufficiency of obvious classification between the notions of context and context raw data (Henricksen, 2003). A disadvantage of Dey’s view of context as “an outcome of interactions between user and application” is that it is inaccurate, particularly in the area of mobile context-aware computing services via wireless technologies. This is where unknown information is transmitted to a smartphone device for a predefined process period (Makris et al., 2013), the mobile deduces the context and advances its implementation without creating complicated computation. Therefore, CA is

## Literature Review

a concept which needs more understanding to enable an investigation of its utilisation and performance in a prototype system. Insight into instruments and theory are also essential to assist this area of study.

The most important objective in context-awareness for mobile computing in the smart home is to have applications that perform accurately and at the exactly appropriate time for the inhabitant. This can be achieved in cases concerning different sorts of context-aware raw data collected from various sensor techniques. In addition, context-aware implementations have used context information from different sources such as inhabitants' 'Activities of Daily Life' and/or by monitoring the environment in order to consider physical action systems using decision-making which depends on other context information (Mann & Milton, 2005).

Among the most important features of this system are sensors and actuators. Any smart home is commonly constructed with rooms such as living room, bedroom, kitchen and bathroom provided with wireless sensors and actuators, for example light sensors, sound sensors, temperature sensors and human body sensors. These kinds of technologies can be designed into the smart home environment and can track the activities of daily life by collecting context data and making an assessment of the existing situation of the resident in order to provide computing service decisions. In addition, the smart home can be reactive, reacting to the context information and other remote controls to make the best choices of appropriate action. It can perform actions in advance if it determines that the situation meets a certain set of conditions, thus triggering a dynamic reaction which should be achieved by a particular process. An actuator is used for creating an action depending on data collected by sensors to be used for an action decision. Currently, developments in technologies permit inhabitants to control home appliances without performing difficult tasks, by operating devices such as a remote control, smartphone or PC through a mere click.

### **2.3 System Architecture for Context-Aware Built-in Smart Home Applications**

A considerable amount of literature has been published on the design and implementation of smart home architecture systems. Diane J Cook et al. (2003) carried out a number of

## Literature Review

investigations into smart home capabilities focusing on three aspects: the house as a place where residents live, the residents' activity and the pervasive workstation system. The authors present an architecture which enhances the 'MavHome' project and defines the role of the algorithms contained within the prototype. The system design of MavHome is divided into four levels, which are: physical layer, communication layer, data layer and decision layer. Some sets of prediction rules have been introduced, for instance: Smart Home Inhabitant Prediction, Active LeZi and Task Markov Model (Cook et al., 2003). The drawbacks of these algorithms are firstly, their simplicity, as they do not have great ability to adapt to modify configurations. Secondly, the whole action history has to be saved and processed offline to return a prediction, as algorithms cannot do this. This function is not suitable for a task that takes a long time. Also the algorithm is designed to predict for the next stage, but not at the same time as a decision is taken.

Chen and Zhi (2011a) propose a prototype named Device Profile for Web Service (DPWS). By offering an interface to enable a service workflow, residents can adapt the performance of appliances by a configuration provision. These system devices have been employed for smart home appliances such as a projector, DVD, speakers, lights and curtains. This categorised system is separated into three layers: physical layer, middleware layer and user layer (P. Chen & Zhi, 2011b). It was found that the prototype system faces two challenges: inflexibility and interoperability of the appliances.

Sang-Hak Lee and Chung (2004) developed a system architecture for context-aware data in the smart home which can support unused implementation. This configuration is based on different layers according to functions: user controller devices, user healthcare, user management and user media. The lowest layer is used for electronic devices and communication technologies; the next layer is offered as a database management service to integrate context data. After that, the context management layer makes a connection with the high levels based on the low level context information. How the high levels are used to make decisions depends on the context information; services and data are offered to the occupants and the context data are labelled for future retrieval. Finally, the highest layer is the application-specific adaptive layer, which provides links between different applications



## Literature Review

and resolves any conflicts (Sang-Hak Lee & Chung, 2004). The main challenge of this model is that it needs human interaction and does not have any intelligent service. Context database history and intelligent decision-making methods should be combined with context-aware computing services as the main techniques of smart home automation.

Modern technology has developed to the point where it is reaching the domestic market in new ways. A smart home with various automated system and devices to make running a house easier is a topical idea which has become fashionable (Kühnel et al., 2011). The use of these devices appears to create few difficulties. To automate a home needs tools specially designed for the purpose and sensible rules for controlling them by means of the particular automatic system chosen. All the tools need to provide information on the home environment and the way the system work (Ghabar & Lu, 2015). In addition to this, the equipment in the automated home can be altered or set in motion by using the controlling tool in a different mode (Kao & Yuan, 2012).

It is unfortunate that as yet smart home equipment uses the available technological knowledge well, but the results are not always useful for the resident of the house. This is shown in papers by Van Hoof, Kort, Rutten, and Duijnste (2011). New methods must be developed which are better adapted to the requirements of the user; they might be called intelligent home equipment and be particularly useful for elderly or disabled people (Ghabar & Lu, 2015). According to Van Hoof et al. (2011), five elements are needed to device a really effective smart home technology: automation in the home, wireless technology, remote control, database and intelligent control.

Detection technologies should be designed to meet new user expectations without causing the user unnecessary technical difficulty, effort or discomfort (Makonin, Bartram, & Popowich, 2013). Furthermore, the cost of embedded electronic systems may be reduced by offering a lower price for the licensing of electronic automation. Because this technology has the advantage of optimising the daily life of the population and creating context-aware help for commercial purposes, it should be acceptable to the population. It

## Literature Review

also has the additional benefits of using the smartphone and monitoring solutions for facilities management at home.

S. R. Das, Chita, Peterson, Shirazi, and Bhadkamkar (2011) focus on the possibility of intelligent home security using smartphones which can remotely contact and control electronic security devices and integrate other services. This study introduces the design and implementation of HAsec, the current Home Automation and security processing system for smartphone devices, which uses mobile technology to provide the necessary security for product and operation-related controls. The HAsec system permits different types of mobile phones to access the web and full browser (Das et al., 2011). An article by Alheraish describes the design of the remote control model Mobile to Machine (M2M), based on the Global System for Mobile communications (GSM) network. The system consists of embedded system, sensor, relay and mobile to control home brightness, monitoring and security devices. Advantages observed during the experimental stage include the system's ability to use different techniques such as SMS and GPRS, and its appropriateness for simple applications using an Analogue-to-Digital Converter (ADC) or Digital-to-Analogue Converter (Han, Han, Zhang, Zhang, & Yang). On the other hand, it also has some drawbacks for which the designer needs to find suitable solutions (Alheraish, 2004a).

It is necessary for the house using a smart home system to be provided with a suitable wireless communication system and security. It is also an excellent idea to use an energy saving power source, for economic reasons. Already there are various technological systems available for the smart home (Ghabar & Lu, 2015).

There are many different kinds of technology that can be built in the smart home environment. Mann (2005) surveyed many requirements related to communication, such as services, automation, residents and house arrangements. In contrast with other existing system designs in smart home architecture (P. Chen & Zhi, 2011a; Cook et al., 2003; Sang-Hak Lee & Chung, 2004), the suggested prototype architecture provides acceptable observation of the collection, distribution and application of context information and shows the importance of context information in computing services. The knowledge detection

## Literature Review

level operates context information and customer interaction levels in order to determine new rules. This is a strength in the system, which is designed for the purpose of achieving more sophisticated system services.

Figure 2-1 summarises most of the techniques and features that can be used to support disabled and elderly people and to develop an ‘independence model’ for an automated smart home service.

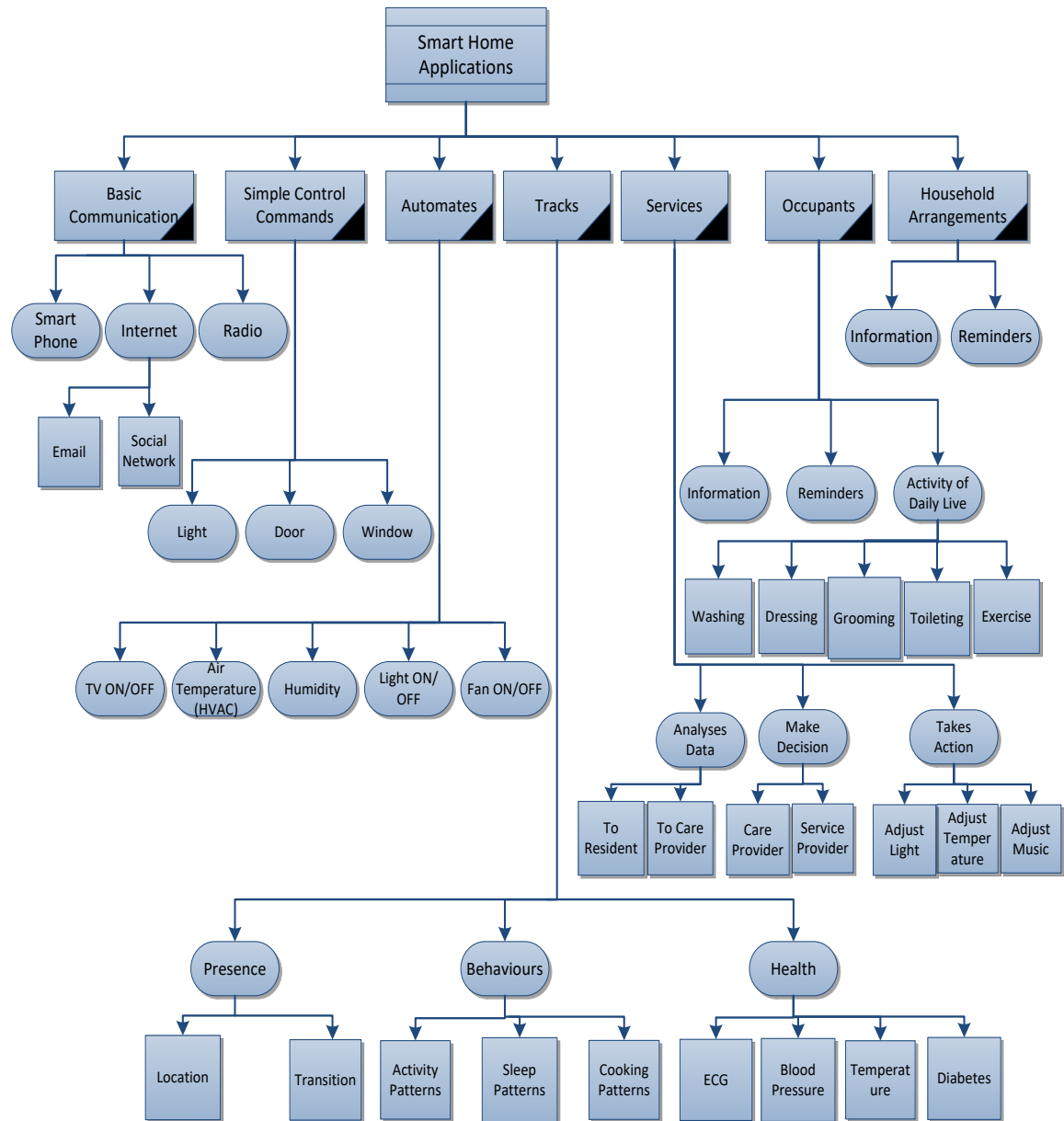

Figure 2-1: Model linking smart home appliances to user needs (Mann & Milton, 2005)

In the smart home setting, it is very important to make context-aware applications available to assist older people to be more comfortable. To succeed in this aim, it is necessary to incorporate various advances in technology into the smart home prototype system.

### **2.4 Wireless Technologies and Smartphone Remote Control**

Several remote control systems for the automated house have been developed in recent years. Modifying research uses the smartphone as the control tool for domestic electronic devices, and it is possible to control an ever-growing array of domestic equipment for both work and leisure. Most electrical items such as lights, heaters, white goods and TVs, A/V players and so on can be adapted to incorporate facilities for control by smartphone and computers. Remote control can be achieved by using one of several media available for wireless communication. There are, for example, mobile phones with internet services, SMS with GSM and Multi Agent Systems (MAS). These can all perform actions such as switching devices ON or OFF, adjusting noise and heat levels and other actions of this kind (Ghabar & Lu, 2015).

At the present time, smartphones are becoming increasingly successful in the area of context-aware services such as smart homes, homecare, healthcare, social purpose applications and safety (Ni, García Hernando, & de la Cruz, 2015). Such services are designed to recognise users' contexts, for example location, current activities, identity and surrounding environment (Sashima, Inoue, Ikeda, Yamashita, & Kurumatani, 2008). All phones also come with the ability to communicate over cellular networks, and most have built-in short range communication capabilities, such as Bluetooth and Wi-Fi, that can allow them to communicate with and control appliances in their surrounding environment (Khan, Xiang, Aalsalem, & Arshad, 2013). Researchers have found that over the last decade, mobile computing services have been commonly accepted and become an integrated digital method of assistance, not only as key computing and mobile communication devices, but also for other purposes, such as predicting the ambient environment, controlling greenhouses and for social networking (Nichols & Myers, 2006; Wazir Zada Khan, Aalsalem, & Arshad, 2013).

## Literature Review

It has been discerned that generally the most convenient piece of equipment to use as a controlling device is the smartphone. This is usually readily available and, with the present better standard of hardware, it provides a superior interface. Smartphone technology has been directed towards the production of context-aware models which contain sensors and actuators. These can gauge the conditions in any particular environment in order to perform the actions which are necessary. The design system for the smart home is one example of the use of such smartphone technology. It includes the tools to help a person to live independently more successfully in his or her own home (Ghabar & Lu, 2014).

Wireless technologies in the smart home have been studied by many researchers. Different types of wireless technology have been explored, such as Wi-Fi IEEE 802.15.4 (Langhammer & Kays, 2011); Bluetooth and GSM (Han et al., 2012); ZigBee (Al Mehairi, Barada, & Qutayri, 2007); and Konnex RF (KNX-RF) (Tajika, Saito, Teramoto, Oosaka, & Isshiki, 2003). Significant progress is currently being made in this field and among the most popular areas of focus are wireless sensors and actuators (J. Zhang, Song, Wang, & Meng, 2011). Moreover, various kinds of technology such as sensors, actuators and home automation devices have been integrated with different wireless protocols for ease of use in control and data gathering. Wireless Sensor Actuator Networks (WSAN) Xia, Tian, Li, and Sung (2007) and Yan, Qiang, and Hong (2011) have also become an active area of research. Sensors and actuators can be used to improve interaction between the client and the physical environment (Hong, 2011). It has been suggested that by 2020, there will be between 50 and 100 billion appliances connected to the internet, and researchers are trying to promote a change in the mode by which each object is interactive (Trappeniers, Feki, Kawsar, & Boussard, 2013). A comparison of the different types of wireless technology is given in Table 2-2.

## Literature Review

Table 2-2 Features of wireless technology

<b>Parameters</b>	<b>Wi-Fi</b> (Langhammer & Kays, 2011)	<b>Bluetooth</b> (Han et al., 2012)	<b>ZigBee</b> (Al Mehairi et al., 2007)	<b>Xbee (RF model)</b> (Tajika et al., 2003)
<b>Supply Voltage</b>	3.3 – 5 V	1.8 V	1.8 V	2.8~3.4 V
<b>Frequency</b>	2.4 GHZ	2.4 GHZ	2.4-2.485 GHZ	2.4 GHZ
<b>Distance Range</b>	Up to 300m	10m-100m	10m-60m	Up to 35m
<b>Data Rate</b>	11Mbps - 54Mbps	1Mbps(Ver-1) 3Mbps(Ver-2)	10Kbps-250Kbps	Up to 250Kbps
<b>Access Connection</b>	Point- to -Point	Point -to -Multi-Point	Point -to- Multi-Point (Mesh)	Point -to- Point / Point -to- Multi-Point (Mesh)
<b>Area Network</b>	Local Area Network	Local Area Network	Local Area Network	Local Area Network
<b>Power</b>	Low Power	Relatively High	Low Power	Low Power
<b>Permit</b>	Not Required	Not Required	Not Required	Not Required

### 2.5 Activity and Monitoring Based on Context-Aware Services

The aim of this section is to review the literature most related to the area of context-aware systems and to obtain and exploit information related to the creation of affordable services which are suitable to specific persons, places, periods and incidents. In 2008, Saizmaa and Kim pointed to some of the ways in which context is essential to the successful implementation of context-aware systems in the smart home (Saizmaa & Kim, 2008), while in 2015, Mafrur et al. published a journal paper in which they describe the use of built-in smartphone sensors to control building requirements without the need for interventions or commands from residents. They utilised these sensors to register activities of daily life while the user was sitting, walking and standing, in order to determine their effectiveness in controlling a prototype smart home system. The authors tested embedded sensors in the smartphone such as an accelerometer for monitoring and identification of user activity, and a magnetic field sensor to determine the location of inhabitants within the indoor location being investigated. They also designed two tools for the decision-making model, one for

## Literature Review

opening the door and another for playing media. This smartphone application can be implemented manually or automatically, depending on the home environment. In this research the experiments were done using the Support Vector Machine (SVM) algorithm to classify the magnetic and accelerometer data; about 92 percent accuracy was realised in terms of the data, but with a considerable delay time of 1180ms. This delay meant that this method of control was not practical in the context (Mafrur et al., 2015).

To manage contexts successfully, activity and monitoring systems in a smart home should enable and support occupants, particularly the elderly, to avoid accidents. Several attempts have been made to recognise and detect falls, including those of people who suffer from illness as well as the elderly, and to provide help immediately. The devices send an alert, message or alarm to the social services using different technologies (Charlon, Bourennane, Bettahar, & Campo, 2013; Sposaro & Tyson, 2009; Yongli, Yin, & Han, 2012). Consequently, context-aware applications have already been explored through the implementation of different technologies, such as wireless sensor networks, smartphone databases and recent devices related to collecting and arranging information (D. Choi, Kim, & Hung, 2012; Herrera, Mink, & Sukittanon, 2010).

This research looks in depth at several of the contexts used and context information, at the many systems that offer, gather and distribute data within the context, as well as at applications which adapt to a varying context. In particular, the research examines devices designed to sense a particular low-level physical context (G. Chen & Kotz, 2000). For example, investigators of the TEA project constructed a multi-sensor model to sense contexts, which included a photodiode to sense brightness levels, double accelerometers to offer vibration measurements, infrared sensors to detect people nearby, an Omni-directional microphone to sense voice and extra sensors for carbon monoxide, pressure and temperature.

Sashima et al. (2008) study investigated a mobile sensing platform which offers context-aware services aimed at mobile operators. In their study, these authors used a smartphone, a mobile sensor router and sensor middleware on a remote server. They found that observing a heartbeat was possible, but that this method was not suitable for monitoring

## Literature Review

apartment temperatures. It was further discovered that Bluetooth and Near Field communication were more convenient methods for a mobile sensor router to communicate with other devices. The article by Dobre, Manea, and Cristea (2011) reports on investigation of a platform for assisting general context-aware smartphone applications. Different sensors related to the mobile phone were used to carry out the experiment. The results show that the proposed methods can offer smart recommendations only at the location that matches the handler. It was also found that the developer could organise an alarm to alert residents utilising vibration, sound and light sensors. The approach by Pung et al. (2009) was to explore activity recognition systems in context-aware middleware for ubiquitous homecare. They employed wireless sensors, mobile phones and gateways (PC) to send information between individuals and the system servers. They found this technique was unique in enabling middleware to realise its best effectiveness in terms of context processing, as well as reliable accuracy in terms of activity detection.

A recent study by Espada, Crespo, Martínez, G-Bustelo, and Lovelle (2012) explored methods that permit web applications to approach context information in a fast and informal way. They used many operating systems for smartphones, such as iOS, Android, Windows-based phones, web OS, Symbian and so on. Moreover, this system includes a context-aware web browser with attaching Extensible Markup Language (XML) labels, which can be used on a web application. The result illustrates that once the application requests context information, the client must make a decision whether to admit the request or not. Also, the resident can use other applications such as HTML. With regard to contextual dependency, more details can be found in a review study by (D. Choi et al., 2012). They offer a prototype context-aware system methodology presented through an Entity Relationship Diagram (ERD). Exploring activity recognition systems based on the iPhone and a database, they report on two different activities: sports and movies. However, the writers predict the traditional outcomes less successfully than the context information in the proposed methodology, because comprehensiveness and consistency need to be analysed.



## 2.6 Potential Models for Monitoring and Control in the Smart Home

A smart home not only depends on equipment, in terms of special appliances such as a sensor, actuator, Wi-Fi transceiver, smartphone and personal computer, but also requires a means of integrating these devices successfully to reach an appropriate standard for monitoring daily life, healthcare facilities and services, as well as other household needs and applications. There is a large volume of published studies describing smart home applications using new technology to support the ageing population (Brown, 2006; Gaddam, Mukhopadhyay, & Sen Gupta, 2011; S.-F. Li, 2006b). The purpose of this section is to consider previous research concerning how much benefit can be gained by using difficult and sophisticated theories that can be simply applied in a smart home. This includes services for environmental control, information access, communication and observation, as well as the use of different emerging technologies (Kadouche, Chikhaoui, & Abdulrazak, 2010).

Many academics and research institutions have recently conducted studies into managing the intelligent smart home environment using an integrated modular Bayesian network with selective inference for context-aware decision-making. Seung-Hyun Lee, Yang, and Cho (2015) describe a request for an uncertain context-aware decision rule utilising a smartphone and personal computer. They propose a technique named the 'modular Bayesian network' to deal with the calculation complexity of context-aware data in complicated situations. The raw data was gathered directly from a smartphone produced by Samsung, with built-in sensors recording such items as location, date, time, weather and schedule. The results illustrate that this method handles data well to decrease time complexity. On the other hand, this study does not use the Bayesian network in the framework as an automatic model. Also, the results are only investigated from the particular dataset, which is arguably not enough to make appropriate decisions regarding context-aware data in the real world environment.

A study published by Meng and Lu (2015) explores the assessment of a rule-based method for a context-aware service using decision making and rough set theory in smart home automation. Their prototype system implemented different types of appliances enhanced

## Literature Review

with wireless technology linked to a temperature sensor, a human body sensor, a humidity sensor, a brightness sensor, an actuator, an embedded system and smartphones. The recommended method proposed using database history and uncertain context information to provide a customer supervision service. The method was implemented to determine its feasibility and complexity. This research presented a context-aware computation to provide home control devices which are workable and observable, and which also reduce the complexity of the data structure. The omissions in this study are that it did not address context-awareness in real-time performance, and did not determine the weight of each context item to make the results of decision making more accurate.

In an article by Chahuara, Portet, and Vacher (2013), the authors address context-aware decision-making in smart home automation built on a probability-based system utilising the Markov Logic Network (MLN). This system handles uncertain information from different sensors in a real smart home environment according to Naïve Bayes techniques. The model is dependent on location and the activity of the resident to make an appropriate decision according to the context data. In this study, the MLN was invoked as the rule for decision making using two functions, utility and action. The utility node had responsibility for describing the decision scenario and the action node was an adaptable node confirming the action to switch the device ON or OFF. The outcomes of making the decisions, according to activity recognition for various locations, show that activity with uncertainty is a little more accurate than without uncertainty. In addition, the statistical method can cope with making appropriate decisions even without complete input information.

In 2005, Mann and Milton published a paper in which they described recent developments in smart home technology. They organise these into six levels: basic communications, simple controls, automatic functions, including lights and TV with timed on/off controls, security systems and environmental temperatures. They then describe the function of tracking residents around different indoor locations as well as their behaviour and health status during sleep. Next, they explain how to analyse information to make sound decisions as well as providing data for normal tasks. Additionally, they provide some personal

## Literature Review

questions regarding making use of the internet, and finally explain how to arrange the smart home by recognising needs (Mann, 2005).

The approach by Demiris et al. (2006) experimented with activity recognition in a sensor network for so-called 'TigerPlace', which helps elderly people to avoid having to live in nursing homes or to spend a lot of money on hospital treatments. With this technology, devices such as a bed sensor, an audio-visual sensor, a cooker sensor and a guitar sensor are employed to monitor well-being circumstances and indicate any unusual action. The TigerPlace system has been designed to be accessible for inhabitants to operate in terms of utilising the interface, maintenance and performance. The model was experimented with in a smart home with two groups of elderly people, both male and female. The result indicates that the system needs to be more automated to decrease the need for community interaction, as well as to reduce the amount of information which, if transferred to other services, may be dangerous.

To make householder appliances and technology more convenient for elderly people who may not be familiar with such complicated functions, it is necessary to find a way to increase awareness and encourage them to be confident in a practical sense. A recent study by Soar and Croll (2007) involved a new development, the Queensland Smart Home Initiative (QSHI), which was supported by the Australian government in 2007. This project used a technique that is capable of improving quality of life by reducing hospital visits for unnecessary reasons, as well as helping disabled people and those suffering from illness to live independently with assistance from information and communication technology (E. Martin et al., 2011).

In the future, sensors are likely to be ubiquitous in the smart home, but there are still many inquiries to be conducted about the kind of sensors and their functions, the exact types varying according to resident behaviour. Makonin and Popowich (2014) suggest a prototype that is used to monitor activity in terms of electric meters, sleep and resident recognition through the Home Occupancy Agent (HOA). In this proposal, they utilised ambient light sensors for detecting occupant behaviour as well as power consumption, and

## Literature Review

then used the data gathered from those sensors, which were saved in the database, to observe whether or not residents were at home.

It is fortunate that recent studies in the area of the smart home have produced new technologies and organisation methods, which have helped the current researcher to engage with the computing, ambient intelligence and smart appliance requirements for automation functions. Carreira, Resendes, and Santos (2014) carried out an experiment to study conflict detection in the smart environment by creating a model for Home and Building Automation Systems (HBAS) based on a network with actuators, Ambient Intelligent systems (AmI) and sensors. This prototype was designed to solve the problem of conflict when it is detected in AmI by investigation of the environment to determine suitable action. It was noticed that if more than one conflict happened at the same time, it was much more complex for the system to detect events and determine resolutions.

### 2.6.1 Supporting Technologies

This section will investigate several technologies which are involved in supporting the context-aware model. Context-aware applications are prompted by many related devices such as sensors, technologies, embedded systems and smartphones. However, these appliances are responsible for different aspects of context information gathering. There are several embedded sensors which can be set up to characterise the situation of a human body and the smart environment, independent of other human interaction, in order to deal with the context-aware computing application. Table Ab-1 in Appendix B shows some examples of sensor data with their specifications. According to this table, the configurations of sensors are dissimilar in resolution, control power, dimension, analogue output and digital output. Consequently, various data processing and communication networks are required in supervision of the different sensors in order to gain convenient values (Meng & Lu, 2015). Moreover, the divergence of the sensor requirements and their diversity in procedures is also an increasing limitation in their real-world application (Makris et al., 2013). As a result of the heterogeneity in computers and other appliances, such as sensors and actuators, it is essential to set up the model architecture to be compatible with various other technologies. Other investigators have argued that in order

to create a 'context-aware computing service', it is important to integrate typical standards which work with diverse appliances (S.-T. Cheng, Wang, & Horng, 2012). This is because context-aware data requires technologies from various sensors and smartphones to service detection and provisioning. Hence, the system architecture requires algorithms to ensure that the interaction of context data is confirmed by statistical methods in order to promote accuracy.

### **2.7 Probability-Based Methods and Applications**

The principal advantage of using statistical methods in the context-aware information service, when compared with other conventional methods, is that it is very simple, capable and performs well at retrieving information as context-aware input that will enable automatic decisions within the automated computer service (Vasilis, 2015). It is widely used in controlling building facilities (Castilla et al., 2011; Cigler & Prívará, 2010; Privara, Široký, Ferkl, & Cigler, 2011). Assessment of the smart home system's performance can be based on statistical context data (Jimenez & Madsen, 2008). In addition, statistical rules and machine-learning tools can assist the relationship between input and output data without the need for additional a priori information (Olanrewaju & Jimoh, 2014).

Thomas Bayes was the son of a British Presbyterian minister, assisting his father and writing on mathematics during the 18th century. His work was not known until after his death, when the Bayesian method was so named. Later, his friend Richard Price initiated an interesting scientific proof using Bayes' ideas, (Poitras, 2013). The possibility of artificial intelligence and decision-making services appeared in literature in the middle of the 20<sup>th</sup> century, in connection with solving the problems of probability theories. More specifically, decision-making methods can provide a useful systematic characterisation of the basis of AmI difficulties. This opinion has been expressed by investigators who have studied many applications involving decision making in different disciplines such as medicine, architecture and computer sciences (Horvitz, Breese, & Henrion, 1988). Earlier, it was not realised that probability methods could be an important implementation approach for artificial intelligence in the application of different services, but in 1955, during the Dartmouth conference, it was anticipated that probability methods could contribute

## Literature Review

beneficial processes to the approach to uncertainty. It was predicted that this would involve a comprehensive requirement for conditional parameters that were infrequently accessible (McCarthy, Minsky, Rochester, & Shannon, 2006). While the Bayesian likelihood model has been known for a long period, it has only been since the latter half of the 20<sup>th</sup> century that there have been well-organised sets of rules and tools to utilise it (Wolpert & Ghahramani, 2005), and that actions or processes making use of conditional independence have been established (Gilks, Thomas, & Spiegelhalter, 1994; Jensen, 1996). These improvements created Bayesian Networks, which are currently considered the best means of enabling reasoning in conditions of uncertainty (Neil, Fenton, & Nielson, 2000).

Moreover, conditional probability presents valuable outcomes in the fields of healthcare decisions, especially for researchers who have insufficient information; therefore, probability is the ideal method of analysis to evaluate the reasonableness of a physical decision (Buchanan & Shortliffe, 1984). Bayesian theory is explained as *“a framework for making inferences based on uncertain information. The fundamental idea is that probability can be used to represent the degree of belief in different propositions and therefore the rules of probability can be used to update belief based in new information”* (Wolpert & Ghahramani, 2005, p. 1). Bayesian networks are now extensively used for various applications as well as solving problems with potential uncertain variables, for example diagnosis, classification and decision making (Mrad, Delcroix, Piechowiak, Leicester, & Abid, 2015; Pourret, Naïm, & Marcot, 2008).

### 2.7.1 Description of the Statistical Rule for Search Engine utilized by TF-IDF

Before undertaking further analysis of the prototype architecture and experiments, it would be beneficial to define the nature of the Information Retrieval (IR) problem for weighted items of context-aware computing attributes and the particular approaches utilised to clarify it. It would also be helpful to clarify TF-IDF (Term Frequency and Inverse Document Frequency), which is a strongly recognised weighting measurement method (H. Chen, Han, Dai, & Zhao, 2015). Information retrieval can be characterised as the function of searching and gathering of context database history to fulfil a requirement (Behl, Handa, & Arora, 2014). The widespread traditional method of weighting items has been to utilise

## Literature Review

TF-IDF for determining the importance of attributes. In considering ways to address the problem of detecting the weight of context items and ranking the context attributes from the database history, a newly developed method was investigated, which includes one algorithm for Event Frequency (EF), Inverse Context Frequency (ICF) and Item Frequency (IF). This does not involve term frequency data from other documents, because all the context data are implemented in rows. This algorithm is constructed to define mathematical and experimental term weights that can be used as input of modelling relevance for the Naïve Bayesian decision algorithm.

Such a committed investigative study can make a difference in determining beneficial applications for the inhabitant in the smart home automation and monitoring environment. Information Retrieval (IR) is one of the search engine's functionalities which can be used to match context-aware terms to the occupant's service requisites. Moreover, the most important feature of IR is that it can significantly improve the effectiveness of information retrieval, since the most relevant context-aware data in the database history should be in the top rank in terms of term frequency (Kehinde & Daniel, 2013). The TF-IDF model was initially created for text document analysis in tasks such as finding term weight in text classification (Zhanguo, Jing, Liang, Xiangyi, & Yanqin, 2011), and for clustering and ranking web documents (Roul, Devanand, & Sahay, 2014). More recently, the terms 'frequency' and 'inverse document frequency algorithm' have been considered by many researchers for various applications, such as recognising activities of daily life (Gu, Chen, Tao, & Lu, 2010; Palmes, Pung, Gu, Xue, & Chen, 2010); semantic recommender systems (Goossen, IJntema, Frasincar, Hogenboom, & Kaymak, 2011); the term weight of context-aware information related to physical activities (J. Chen, Wu, Guo, & Wang, 2012; ZENG, 2012); and context-aware information in the smart home for automated facilities (Ramparany, Benazzouz, Gadeyne, & Beaune, 2011). Studies by Inventado et al. (2013) and Kurihara, Moriyama, and Numao (2013) describe a novel idea for extracting significant context-aware activity from the smartphone based on a method called Event Frequency - Inverse Context Frequency (EF-ICF).

## Literature Review

This model depends on two types of context-awareness involving location and time to calculate probabilities and thus find the most suitable application for the user. In each context-aware situation, the created menus are designed to find which application is best as a recommended system for the client. The performance outcomes indicate that the proposed algorithm could be less complicated than other methods such as Kamisaka, which is aimed at the influence of the context-aware application.

On the subject of context-aware services, Ramparany et al. (2011) offer an automatic learning system to develop the efficiency of context-aware services from the sensor history database to control home facilities, for instance to switch a light on or off. In this study, the authors used TF-IDF in parallel with texts and situation graphs to resolve the differences between context data and the location of graph models by measuring the similarity. TF-IDF is a suitable method for dealing with significant issues of customisation, service and information retrieval, such as term weight, computerised context learning and clusters. Moreover, the data processing is not so important in this situation, because the home automation may be dependent on practicalities within the physical world.

The article by H. C. Wu, Luk, Wong, and Kwok (2008) uses the statistical rule of TF-IDF to retrieve context-aware information by using the weight terms later utilised in decision making to determine the location of context. In this paper the authors develop a formula named the “Probability Ranking Model” for irrelevant usage terms by inverse document frequency. Their investigation supports the use of context items for local appropriate decision making via group-related context as a special case of a term. The limitation of this rule is that only one group matches the model, though in reality there may be more than one group that is relevant.

Another study by Gu et al. (2010) states that inhabitants’ activities in the smart home are a significant issue, based on using a thumbprint to recognise actions without data labelling. The authors utilised wearable wireless sensors to gather real-life context-aware information from seventeen activities in home environments. The TF-IDF terms model was built after extracting fingerprint information from the database to measure terms and to ‘weight’ activities. The main object of this study was to extract the weighted terms and store them



as patterns to compare each class of activity, for example, brushing teeth and making coffee, with the next data process being to identify the activity. This algorithm addresses real-world data collection from Radio Frequency Identification (RFID) to evaluate the effectiveness of the model and compare results between the Hidden Markov Model (HMM) and TF-IDF models. The results show that the performance of TF-ICF is much better in scalability than the HMM rule.

### 2.7.2 Naïve Bayesian Decision Making

The main goal in this section is to identify methods which have been reported in previous studies of service applications in the smart home context. It also aims to offer a brief outline of an approach which has made a considerable contribution in this field of study. Handling the complexity of the intelligent home environment should be implemented by a variety of methods which ensure the accuracy and response time of building information. The Naïve Bayesian decision-making approach deals with this complexity by following the events involved in different tasks, which are executed in various modes, to determine aspects such as accuracy and response time. Naïve Bayes has been defined as a “*classifier [...] based on Bayesian statistical principles. It is good for coping with decision-making in uncertain situations*” (Q. Wu, Bell, & McGinnity, 2005, pp. 3-2). Various researchers have recognised that the exactness of Naïve Bayes is very effective in decision making and classification compared with other approaches such as Decision Tree and rule-based learning, particularly if the amount of information is not large (Hand & Yu, 2001; Zaidi, Cerquides, Carman, & Webb, 2013).

Further studies of smart home automation have highlighted the significance of using concepts of both Naïve Bayes and the Hidden Markov Model (HMM) to achieve efficiency in the decision-making system. A relevant piece of work by B.-C. Cheng, Tsai, Liao, and Byeon (2010) describes a model named the Adaptive-Learning HMM, which integrates the Baum-Welch and Viterbi methods to investigate performance in terms of accuracy and capability. The results of this model indicate that NBD can provide a practical result as a powerful reorganisation of the activity of daily life in the smart home situation. Babakura, Sulaiman, Mustapha, and Kasmiran (2014) study shows that the HMM method had an

## Literature Review

accuracy of 95% and a response time of 0.008ms, while the performance results using the NB method showed an accuracy of 90% and the time consumed to make a decision was 0.012ms. However, another study reports that utilising passive sensing to attribute the activity of more than one resident in the smart home obtained an average accuracy of 96% using the Naïve Bayes algorithm (Crandall & Cook, 2008).

The Naïve Bayes algorithm is regularly utilised in practice because of its simplicity and the small amount of classification of terms required. In general, the system is utilised for classification decisions. According to D. J. J. H. Martin (2016) “Naïve Bayes Classification”, depending on the attributes of evidence variables intended for a certain occurrence, the class of that occurrence is the one most likely to exist. It is necessary to calculate the evidence to make an appropriate decision between classes  $A_1$  and  $A_2$  within the range of the model.

The use of probability in artificial intelligence has been encouraged by research of a modelling graph that became extensively acknowledged and established after an exceptional study (Pearl, 2014). Linking likelihood with the relationship between evidence and finding (class) requires a graphical model (Whittaker, 2009), which displays the data visually with conditional independences between variables in a particular problem. From the viewpoint of probability derivation, however, the impression is that it is easier to simply investigate the track of the path inference, which indicates the variables from evidence to finding. The Bayesian Network can characterise in cooperation with these variables, which effectively means that ‘effect to cause’ or ‘cause to effect’ are statistically equivalent (Neil et al., 2000). The relation between any two variables that are situated as conditionally independent do not have any direct influence on the value of others. For instance, where  $C_1$  is conditionally independent of  $C_2$  given A, and  $C_2$  can be conditionally independent of  $C_3$  given A, then the same applies for all other attributes.

Wang, Rosenblum and Wang (2012) explore the idea of using probability-based rules to service the use of music over a long period, whereby context-aware information is applied to construct and offer a recommendation service for music. This uses a mobile device built with wireless communication technology and sensors. The model is based on 1) gathering

## Literature Review

the context information for music over a short period, and 2) content analysis to show good outcomes in accuracy and ease of use. The authors employed the Naïve Bayes algorithm to evaluate the results in real time by updating the information to make it relevant to a specific user, and thus convenient to achieve context data. They found that, based on a dataset of 1200 classified songs, the results showed the system could provide good recommendations even without the interaction of the inhabitant (Wang, Rosenblum, & Wang, 2012).

In a recent study published by Shahi, Sulaiman, Mustapha, and Perumal (2015), the authors aimed to assess a smart home framework system which included sensor datasets such as fire alarm, audio system, door sensor and CCTV data, using Naïve Bayesian decision theory to make decisions in the home environment. With increasing numbers of appliances from different technologies, a system becomes more heterogeneous. The authors offer a model to solve the complexity and interoperability problems and to guarantee that home automation works successfully by applying intelligence to making a timely decision. This method proposes that an action could be made systemically in real time by invoking statistics-based rules with event-condition-action for decision making in the smart home. The results show the average run time of a five-fold cross-validation system using five heterogeneous devices in a smart home; these results include CCTV with a run time of 0.1191ms; energy management with 0.1012ms; fire alarm with 0.1973ms; main door with 0.1344ms; and public address with 0.1206ms. The outcome suggests that the Naïve Bayesian model has the greatest ability to work with intelligent building models, even when the system is heterogeneous, to trigger the devices without any other interference.

Zwartjes, Havinga, Smit, and Hurink (2012), investigated the procedure of a Naïve Bayes classifier in the limited area provided by a wireless sensor network using a dataset. They analysed the feasibility of the sensors' dataset for the events of 'open the fridge door' and 'operate coffee machine', making this experiment applicable for home automation application. However, the limitations of this method are incomplete design and implementation of the hardware system; in addition, the dataset needs to be saved frequently for training. Previous research has been undertaken to model the application of

## Literature Review

Naïve Bayesian classification to context-aware information in order to provide services by retrieving and extracting the data from low layer to high layer. One study attempted to utilise the Naïve Bayes decision theory to realise data illustrating a resident's physical activity from context-aware information involving six types of items, including user identity, date and time, location, behaviour, service and stress (J. Lee, Oh, & Jeon, 2007).

From previous studies, it can therefore be argued that the Naïve Bayes algorithm has the following benefits: (Vazirgiannis, 2006) it can be used as a training model in a highly efficient way; (Vazirgiannis, 2006) it is a very efficient method of classifying database attributes; (3) Naive Bayes decision making has implemented conditional independence in several applications and works very well in complex real-word environments; and (4) it is also a suitable algorithm when required to work in combination with another model such as the mixture model, especially in an iterative way. Because of these advantages, the Naïve Bayesian decision method has been chosen as the major part of a context-aware computing service model for smart home automation in this work.

### **2.8 Hybrid Intelligent System**

The Naïve Bayesian decision model is a good option for promoting the interoperability of heterogeneous systems in an intelligent building environment. Several applications of context-awareness have recently been emerging to provide different personalisation services in the smart home environment. These are designed to support inhabitants in making the right decisions when extracting information from various types of context-aware sensor, for example, time, location and physical activity, as well as home environment information such as temperature and humidity, sound and so on. These contexts are intended to support automated services in the real world relating to activities of daily life, for instance home care, home automation, accident, health care and security. In order to arrange for a more efficient service, many context-aware services have attempted to utilise statistics-based models such as Naïve Bayes decision making with TF-IDF, which are the most common techniques for dealing with integration of context-aware information.

## Literature Review

In 2007, Duan et al. published a paper in which they describe a hybridisation methodology that combines rough sets, fuzzy sets and TF-IDF for information retrieval from a preference web. They propose these methods for three reasons: (Vazirgiannis) to discover personalised preference and handle uncertainties within documents in order to measure similarity using the Variable Precision Rough Set Method (VPRSM); (Vazirgiannis) to retrieve relevant data for ranking as well as the weight of terms vector utilising a search engine (TF-IDF); and (3) to mix the rough set with fuzzy sets that are suitable for coping with significant real-value, weighted, computing web information retrieval and classification. The experimental outcomes indicate that the performance of a hybridisation algorithm has great information retrieval potential in documents classification (Duan, Miao, Zhang, & Zheng, 2007).

Several researchers have been mentioned for their studies regarding the hybrid methodology of combining two algorithms in the classification of smart home activity to produce a better service performance. The authors Fahim, Siddiqi, Lee, and Lee (2010) combined the Naïve Bayes classifier with K-Nearest Neighbour to monitor the activity of daily life in a smart building. They provide a technique with two levels: the first stage is utilising K-Nearest Neighbour to compute the important regions where the activity happens, and to decrease the number of terms to be more compatible with the recent attribute vector using Euclidian distance. After that, Bayes is used to classify the maximum probability by calculating posterior and prior data to update the same vector and place. In this experiment, the researchers used various kinds of smart home environment sensor such as a humidity sensor, a light sensor, temperature sensors and location sensors to distinguish the activity of the residents. The results of the model show some improvement in the execution time as well as in the accuracy of the classification. In a hybrid methodology study of a machine learning system, Trstenjak, Mikac, and Donko (2014) investigated using the TF-IDF technique with the K-NN method in a prototype system for decision-making classification. At the beginning of the experiment, they selected the weight value by the TF-IDF method and placed it into a special matrix to reduce the time complexity. The next stage was to identify the K value of K-Nearest Neighbour in order to measure the similarity between the vectors. They evaluated this architecture model in terms of the time

## Literature Review

complexity and accuracy of decision class using the mixture of TF-IDF and K-NN, which gave good modification performance for the classification decision algorithms.

An article by Coppola et al. (2010) explores using a web search engine and artificial intelligence as retrieval technology for context-aware information. They implemented their experiment with software applications via smartphones, such as iPhone, Windows Mobile and Android. They designed a combination of a TF-IDF statistics rule with a Bayesian Network approach, whereby the rule-based structure processes the existing context to make information items easier to use and plans the attributes by means of Bayesian Network. The specific context items were acquired from smartphone sensors, for example light, temperature, time and location, by taking advantage of the wireless network. The main advantage of this method is that the users can retrieve information quickly wherever they are by using mobile phones and a context-aware browser (Inventado et al., 2013), with a query facility giving the user more appropriate and useful information. In addition, a search engine is capable of searching automatically for applications and pages on the web browser. The weakness of the model is the limitations of the smartphone computation using a statistics-based rule and a context-aware browser. Moreover, this model is incomplete in terms of context data weighting for finding suitable terms values for the surrounding location.

A report published by Babakura et al. (2014) tried to assess the Naïve Bayesian and Hidden Markov systems in the smart home situation by investigating the accuracy and reaction time of the dataset. They addressed the complexity and effectiveness of Naïve Bayes decision making in dealing with events that make the house uncomfortable. The model architecture contained home automation, alarm and security, and power management systems. Because of de-stabilising events that happened during dataset handling, which affected the accuracy of decision-making, they proposed the Machine Learning Theory to resolve the difficulties. The recommended algorithm shows that both Hidden Markov and Naïve Bayes performed respectably with regard to time and accuracy for the building dataset.

## Literature Review

Each algorithm model has its strict rules in processing contextual data and provides a much appreciated computing service for context-awareness. From previous studies in the area of computing service, it is clear that using a structured model in context-aware computation is essential to the development of an automatic user service. However, depending on the context-aware database history, the relationship between attributes may be complicated. Employing a fuzzy method to cope with context-aware sensing data would not be appropriate, as it cannot be utilised for comprehensive reasoning with uncertain data, even though it is appropriate in other areas. “Fuzzy Logic (FL) is not adequate for reasoning about uncertain evidence in expert systems” (Elkan et al., 1994). Using both statistical models such as EF-IDF-IF and Naïve Bayes algorithms in the smart home environment makes the relationship between the two models more accurate. Therefore, the combination of statistical-based rules, machine-learning service, and search engine rules can make executing the service easier when the data has invoked the algorithm, as well as leading to very fast computation performance and implementation.

The combination of two algorithms has been used in the present research. Event Frequency- Inverse Context Frequency - Items Frequency (EF-IDF-IF) is implemented to work together with Naïve Bayesian decision making in the area of a probability-based system responsible for a context-aware smart home automation service to assist occupants in their daily activities. These combined methods are appropriate to build into a prototype system for context-aware decision-making; however, some of these methods also need to use training data.

### **2.9 Decision Making Utilising Machine Learning Probability Methods**

From the literature reviewed to investigate the most appropriate algorithms in a context-aware decision-making model using supervised machine learning applications, it is evident that machine learning can indeed support decision making in smart home automation. Previous studies in the area of smart home applications utilising machine learning and search engines have shown an improved functionality of decision making in different respects. In terms of machine learning development, four well-known algorithms were found among context-aware applications in smart home facilities, namely the Naïve Bayes

## Literature Review

classifier, Bayesian Network, Hidden Markov Model and Decision Tree. It was also found that there was some use of Support Vector Machines and clustering technique K-Nearest Neighbour (Kapitanova & Son, 2012). This research aims to design context-aware computing service algorithms which work by automatically sensing the status of the system from raw data utilising machine learning tools (Krishnan & Cook, 2014). Machine learning has been used in many areas of wireless sensor networks and their applications, for example resident activity (Aggarwal & Ryou, 2011; Tapia et al., 2007); smartphones (Györbíró, Fábíán, & Hományi, 2009); smart home automation (J. Choi, Shin, & Shin, 2005); and wearable sensors (Mukhopadhyay, 2015) (Krishnan & Cook, 2014). There are also methods which combine several abstractions to give good accuracy.

### 2.9.1 Context-aware Abstract Method

Context data that have been retrieved in the form of raw sensor data cannot be utilised directly using the context-aware application. The raw sensor data require abstraction and normalisation operations (Meng & Lu, 2015). In order to derive the context data from the low-layer sensing information, several methods may be involved. The best approach to utilise is determined by the features of the different sensor data and the employment of a case study. Following the related investigation in this study, the threshold method has been used for context abstraction.

Heinz, Kunze, Gruber, Bannach, and Lukowicz (2006) suggest that the threshold technique is the simplest method for raw data abstraction, and is suitable for uncertain sensor data. This threshold method can be described in the following equation 2-1. Where attribute  $x$  is the raw context data,  $a$  and  $b$  are possible high-layer results in the context-aware model:

$$f(x) = \begin{cases} a, & x > Threshold \\ b, & x \leq Threshold \end{cases} \quad 2-1$$

### 2.9.2 Bayesian and Naive Bayesian theories as dependent and independent conditional

There have been some challenges for practitioners attempting to utilise Bayesian networks to solve factual difficulties. “Specifically, practitioners face two significant barriers” (Neil et al., 2000, p. 257). The first barrier is that of specifying the graph structure so that it is a sensible model of the types of reasoning being applied. The second barrier is that of



## Literature Review

eliciting the “conditional probability values” (Neil et al., 2000). Larrañaga and Moral (2011) review the method of using Naïve Bayesian graphical models to solve features which are challenging for the main frameworks of decision making, classification and adaptation. The authors mention in their study that the statistical graphical model, which is the existing algorithm for decision making, does not need extensive calculations and offers a tool based on a clear process which is easily used. Additionally, Naïve Bayes classifiers have been used as statistical models to predict class probability in given documents, and this prediction of likelihood is also utilised in other applications for decision making (Joachims, 1996).

There are different structures needed to model the Bayes system of d-connections and their operatives, and three kinds of conditionally dependent connections, namely, pipeline, converging and diverging, can be implemented (Neil et al., 2000). Alheraish (2004b) shows the pipeline connection if attribute C is conditionally dependent on B and node B is conditionally dependent on A. While attribute B becomes evidential, attributes A and C become conditionally independent. In Figure 2-2, Babakura et al. (2014) show the converging connection where attribute B has conditional independence from both nodes A and C, yet even if attribute B has been entered with evidence, it will be updated by attribute C. Figure 2-2 also illustrates the diverging connection, where attribute B is hard evidence that affects both attributes C and A, but evidence entered at attributes C or A will not affect attribute B. In this condition the situation becomes conditional independence for both nodes A and C (Alheraish, 2004b).

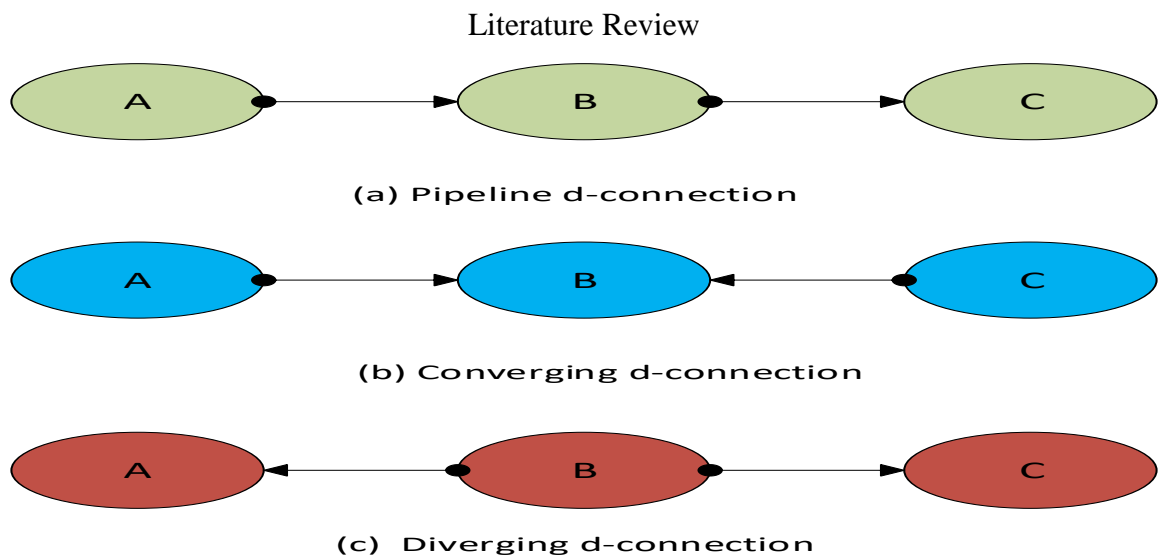

Figure 2-2 Relation between connections: (a) Pipeline, (b) Converging and (c) Diverging  
(Babakura et al., 2014)

In this research relating to future activities, it is necessary to choose a method of monitoring and controlling activity through an algorithm that will enable many applications to support the elderly in their smart homes. Bayesian network theory Alam et al. (2012b) and Z.-Y. Chen, Wu, and Fu (2006) is clearly the obvious route to follow in working with challenges within the smart home environment. This will be dependent on information gathered from the environment from various kinds of sensors that can receive data, such as brightness of light, humidity, smoke, obstacles to be avoided and temperature. This data will then be displayed on the smartphone held by the elderly person.

Actuators are a necessary part of the control system for equipment in the smart home. Their function is to keep the electrical devices of all types working within the required limits of the data which is collected. As an example, temperature and light may be controlled by automatic, immediate ON or OFF commands, or as desired by the homeowner. In fact, the smart home intelligence system is a Bayesian Network (Alam et al.), using sensors developed to react in any environment where it is possible that a consequential change may happen. It is also possible that a BN can be used in the same way to produce reactions to the environment from the equipment. Proof of this is that if devices are correctly switched ON/OFF by machine learning of the received data, automation can give superior responses. An example would be the adaptation of light and fan levels in a room (Ghabar & Lu, 2014).

## Literature Review

There are two steps necessary to classify the configuration and attributes of the Bayesian network model. Initially, constructing the model from the available information or data depends on meeting the challenge of how to collect a sufficient amount of information. The next task is to design the physical structure, which must be based on the domain knowledge used for construction of the whole BN model. This domain knowledge is required to identify the parameters. This is very significant, because without reliable information there will be real-world difficulties (Park & Cho, 2012). Song and Cho (2013) simplified both numerical and experimental prototypes for placing a context-adaptive operator interface to regulate devices throughout a smart home environment. They utilised a Bayesian system to predict the required device in different conditions and used a behaviour system to choose the function that would establish an adaptive system in some situations. The outcome showed that the Bayesian system successfully anticipated user requirements by assessing inferred results for the required equipment based on previous situations (Song & Cho, 2013). The results of research by Könönen and Mäntyjärvi (2008) suggest that, depending on a good choice of elements, even a simple algorithm of linear order will produce an adequately successful result. However, Yap, Tan, and Pang (2007) made a comparison which discovered that the Bayesian Network is more successful than J4.8-DT in producing accurate bases for future context-aware suggestions when very large amounts of context data are present, and even when some context is unavailable. Figures 2-3 illustrate an example of a typical Bayesian system.

## Literature Review

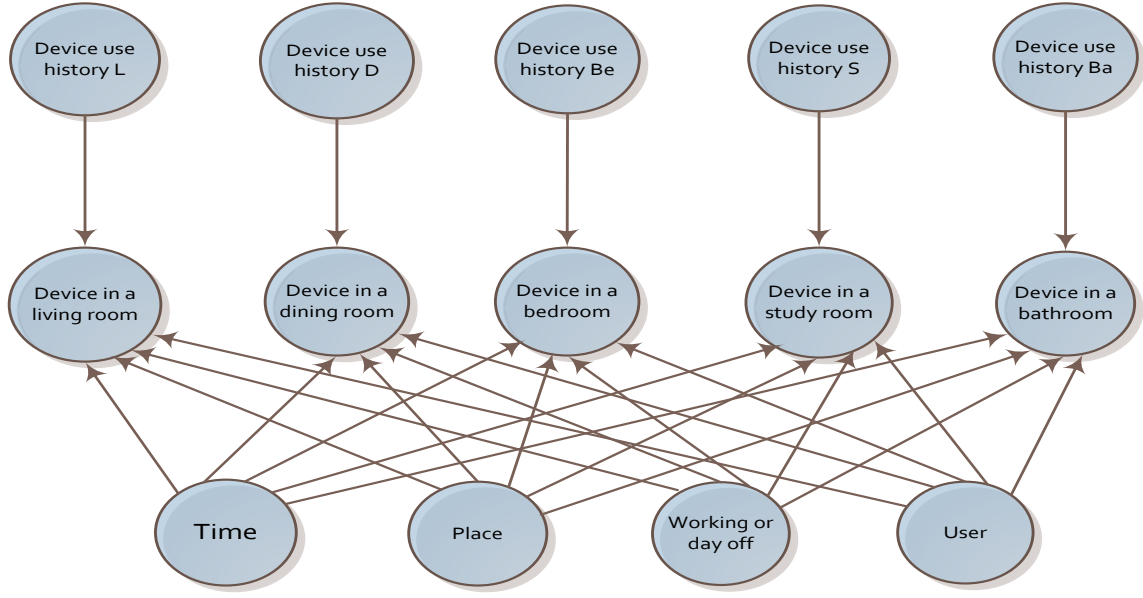

Figure 2-3: Bayesian model (Song & Cho, 2013)

$$P(B, \theta b) = P(x_1, x_2, \dots, x_n) = \prod_{i=1}^n P(X_i / Pa(X_i)) \quad 2-2$$

In the above equation (2-2), the BN is represented by  $P(B, \theta b)$ , which is a probabilistic model that refers to a set of variables  $P(x_1, x_2, \dots, x_n)$ . The construction of  $B = (V, E)$  is known as a Directed Acyclic Graph (DAG) separated by two sets, one being  $V$ , a set of nodes, and the other being  $E$ , represented as a set of edges. On the other side,  $\theta b$  represents the conditional probability of  $P(X_i / Pa(X_i))$ , where  $Pa(X_i)$  is denoted as a parent node of  $X_i$ .

### 2.9.3 Hidden Markov Method

Rabiner (1989) shows how HMM can be applied to a difficult selection system in the recognition of voices. This method is based on generating likelihood classifiers that can model the probability of a state of hidden situations, given a state of observations as input structures with respect to time (Lim & Dey, 2010). The Markov method has been modelled depending on the first order stage, given previous conditions that affect the next stage, and where only the existing situation impacts on current observation of sensing data. This model involves a hidden variable  $y$  and an observable variable  $x$  at each time step  $t$ , as

shown in Figure 2-4. HMMs have been utilised in different prototype systems, for example detection of abnormal behaviour (Kang, Shin, & Shin, 2010); context-aware speech decision in the smart home (Chahuara, Portet, & Vacher, 2012); and saving energy (Thomas & Cook, 2016).

The observable variable at time  $t$ , specifically  $x_t$ , is determined only by the hidden variable  $y_t$ , at that time stage. These Markov properties denote that the combined distribution of an order of states and observations can be described in the following formula:

$$p(y_{1:T}, X_{1:T}) = p(y_1)p(x_1|y_1) \prod_{t=1}^T p(y_t|y_{t-1})p(x_t|y_t) \quad 2-3$$

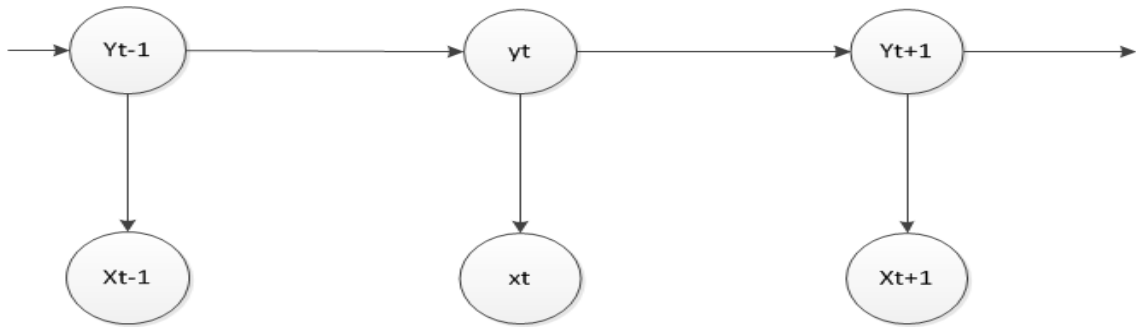

Figure 2-4: Basic graphical model illustration of conditional independence of HMM (Brand, Oliver, & Pentland, 1997)

#### 2.9.4 Support Vector Machines

Investigations have been made into human physical recognition in ordinary life settings where the size, material and position of the mobile-holding pocket differs. Sun et al. (2010) achieved successful results in this area of research by using a SVM-based classifier algorithm. The SVM decision method has the following formula (2-4), and Figure 2-5 shows an example of two vectors:

$$f(y) = \sum_{i=1}^N a_i k(x_i \cdot y) + b \quad 2-4$$

Where  $i$  is the length from '1' to  $N$ ;  $x_i$  and  $x$  are the input product between support vector  $x_i$  and support vector  $x$ ; and  $k$  is a Kernel positive definition.

The SVM algorithm is constructed according to the hyperplane classifier (Cortes & Vapnik, 1995).

$$(w \cdot x) + b = 0, \quad w \in R^N, \quad b \in R \quad 2-5$$

According to the decision function

$$f(x) = \text{sign}((w \cdot x) + b)$$

2-6

Where  $w$  is a weight vector normal to the hyperplane,  $x$  is input vector and  $b$  is a bias or the intercept.

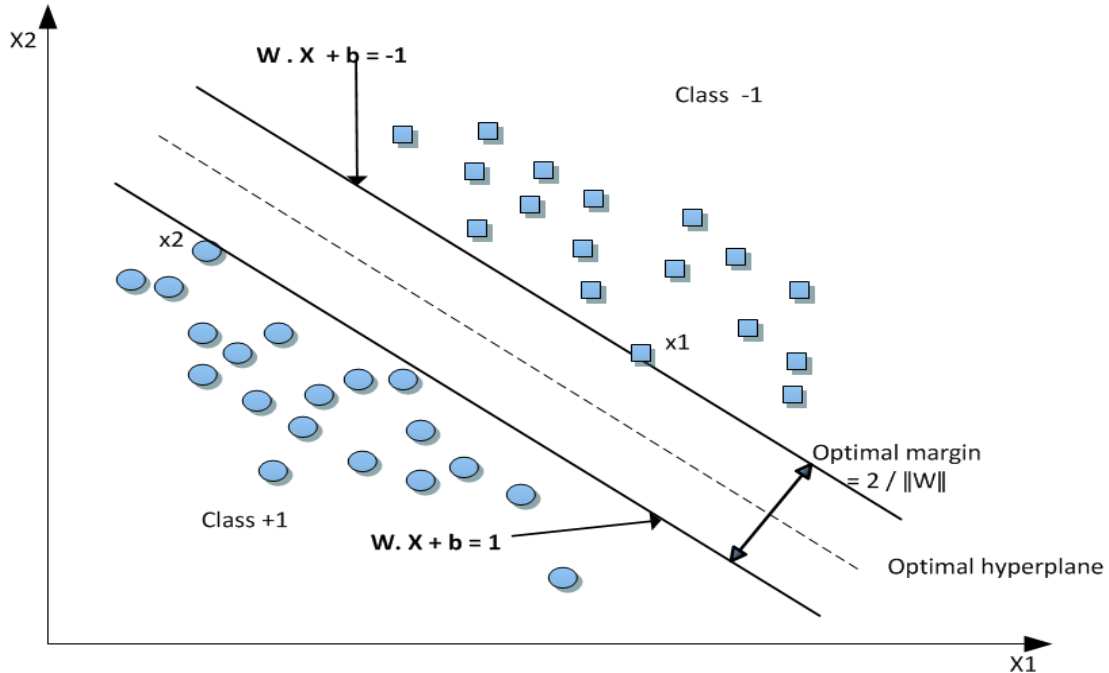

Figure 2-5 SVM classifiers of optimal margin and hyperplane of two classes

### 2.9.5 Decision Tree

The Decision Tree (DT) is comparable to other approaches in machine learning probability algorithms and can be considered as one of the effective methods of decision-making action instance (Stankovski & Trnkoczy, 2006). The main target of the DT learning system is to generate typical models which anticipate the output results according to the input data. From each parent (node), there are children (edges), where there is one or more value(s) from the input variable. The main limitation of the Decision Tree is that the processing of data training will create induction, and this induction makes the model less effective than the Naïve Bayes model (Kononenko, 1990). Also this approach is often weak when large amounts of data are gathered (Maurer, Smailagic, Siewiorek, & Deisher, 2006). However, Chernbumroong, Atkins, and Yu (2011) implemented two classification methods, Artificial Neural Network (ANN) and DT C4.5, for resident activity of daily life

## Literature Review

recognition utilising one accelerometer sensor. The outcomes illustrate that DT C4.5 obtains achievements of 94.13%, which are better than the ANN results of 90.13%. Both algorithms were tested with four attribute datasets.

Table 2-3 lists the suitable methods which can be used for these abstractions in a context-aware computing service. As the table shows, a large number of methods have been investigated and some good potential has been shown in the results. Various mobile devices and technologies can be used, but sometimes the mathematical computations present a severe test of their capacity. As a result, research has also focused on further investigation of complex mathematical methods, with particular attention to their practical adaptation for the mobile computing situation. Most of the methods that are relevant to a context-aware computing service have been studied in a smart home environment.

## Literature Review

Table 2-3 Context-aware Algorithms and Devices Investigated

	People's Work	Methods	Investigations	Advantages and Limitations	Tools		Accuracy
					Software	Hardware	
1	(Medjahed, Istrate, Boudy, Baldinger, & Dorizzi, 2011)	Fuzzy Logic (FL).	The aim of this paper is to investigate a healthcare monitoring system for elderly people in smart homes. They used a prototype system named Environment Multimodal pour la Televigilance Medicale (EMUTEM).	This model involves the low-computational limitations which are a feature of the fuzzy method.	Lab-windows CVI and C++.	Microphones, infrared sensors, ZigBee, PC and RFpat wearable device.	Alarm detection 95%. Localisation 97%.
	(L. Zhang, Leung, & Chan, 2008)	Fuzzy Logic (FL) and Fuzzy Neural Network (FNN).	They propose a system to control equipment at home by collecting data from various environmental sources. Three scenarios have been used.		SPI serial interface. Assembly language programming.	MCU AT90S8535, Optrex DMC 16207 LCD, humidity sensor, TV, alarm, internet, database and X10 and Bluetooth communication.	The RMSR and MAPE are used. FL with 48% to 67%. FNN between 64%-76%.
2	(Kadouche et al., 2010)	Support Vector Machines (SVM).	Studied the behaviour of residents during grooming, breakfast and toilet activities. Experimenting with the CASAS		Java software.	Temperature sensors, motion sensors, door sensors, kitchen equipment sensors and actuator light controls.	Grooming: 96% Breakfast: 70% Toilet activities: 100%.



## Literature Review

			technique for smart home development.				
	(Sashima et al., 2008)	Machine (SVM) and Nearest Neighbour Learning (NNL).	The prototype aims to control room temperature and humidity, as well as to analyse healthcare data services using a mobile phone.	The limitation of this study that there is more than one interface for monitoring which makes the applications incompatible.	Java (J2ME CLDC edition).	Mobile sensing platform called CONSORTS-S, 3G phone, actuator electrocardiograph, skin thermometer, three axis accelerometer and room temperature sensors.	
	(Ueda, Suwa, Arakawa, & Yasumoto, 2015)	SVM	Smart home living activity recognition according to power consumption.		Weka tool.	Power meter with CT sensor, ambient sensor, ultrasonic distance (Dragon), door sensor and faucet sensor. Wireless (ZigBee).	86.9 % in level-room position.
3	(Kang et al., 2010)	HMM and Hierarchical Hidden Markov Model (HHMM)	To investigate both normal and abnormal resident behaviour in a smart home using the HHMM method.			Sensors installed on the fridge door, microwave, oven, cabinets and light switches.	HHMM with 92.14%. HMM with 85.47%.

## Literature Review

	(Van Kasteren, Englebienne, & Kröse, 2010)	Hidden Markov Model (HMM) and Conditional Random Fields (CRF).	Monitored the elderly at home to recognise the effectiveness of activities during cooking, toileting and bathing using a wireless sensor network and datasets recorder.	The strength of this model is that it can integrate all kinds of attributes without any independence expectations.		Technologies used are: read switches, pressure mats, mercury contact, temperature, passive infrared and float sensors.	The HMM performed better in the class accuracy than CRF.
	(E. Martin et al., 2011)	HMM	Location and activity recognition.	This approach is not suitable for smartphone because the rate is not enough for indoor physical activity.		Wi-Fi access point, waist accelerometer, DTV and Motorola Droid.	90%.
4	(Song & Cho, 2013)	Bayesian network	They applied both numerical and experimental systems to control various appliances in the smart home environment.	The Bayes network can be predicated on the residents' requirements based on different scenarios. The weakness is that the experimental work has been conducted without improving the model by training data.	1-XML. 2-Python and 3-JavaScript.	TV, fan, light, computer, phone, alarm, radio and coffee maker sensors.	The average would be more than 80%.
	(Saponas, Lester, Froehlich,	NBN	Activity classification utilising Weka tool machine learning.	The experiment has been conducted without any client or scenarios.	Objective-C.	iPhone SDK and 3-axis accelerometer.	97%.

## Literature Review

	Fogarty, & Landay, 2008)						
5	(Bieber, Luthardt, Peter, & Urban, 2011)	DT	Human activity daily life recognition.			X10, Sony Ericsson, Android 2.2, accelerometer and sound sensor.	Qualitative analysis.
	(Karantonis, Narayanan, Mathie, Lovell, & Celler, 2006)	DT	Long-term ambulatory monitoring.	The weakness in implementing such a system is the experimental outcome achieved with real-time activity needs to be more feasible.		Triaxial accelerometer, local computer and ADXL210E.	Total accuracy (90.8%).
6	(Brezmes, Gorricho, & Cotrina, 2009)	KNN	Real time monitoring of human activity of daily life to evaluate the feasibility of developing new application.		Java programme and Python API.	Accelerometer and Nokia N95.	70%.
	(Lombriser, Bharatula, Roggen, & Tröster, 2007)	KNN	Human body activity recognition and monitoring.	TinyOS has the ability to connect with various platforms, which reduces effort. Simple to deal with algorithm.	TinyOS.	Microphone, accelerometer, light sensor, MSP430F1611MC	91%.

This table presents a comprehensive literature review of methods applied in the smart home. A short background relating to the organisation and classification of the literature review was mentioned in the introduction. A review of condition-monitoring techniques relating to wireless sensors has also been undertaken, based on previous research in which the use of methods for different applications of FL, FNN, SVM, KNN, HMM, DT, BN and NN have been studied. According to these studies, some limitations have been found; for example, FL reveals a lack of mathematical explanation, particularly in the stability of the system model; NN is not appropriate to work within a sensor environment, because each sensor needs to be set to a configuration; SVM shows problems in describing prior possibilities; and HMM demonstrates complexity once there are different hypotheses and events to overcome. In addition, the main weaknesses of HMM include the nonexistence of hierarchy in this type of modelling, and problems with processing large volumes of sensing information from the physical layer. The main drawback of BN is the inflexibility of accurate probabilistic inference. Some of the studies have mentioned the accuracy rate when investigating the performance of the methods. From these investigations, it is simple to determine the context-aware abstraction when using a mobile phone compared with other, traditional, platform-based models.

### **2.10 Machine Learning Using Weka Tool**

Machine learning is defined by Ayodele (2010) as “programming computers to optimize a performance criterion using example data or past experience”. Analysis of context-aware computing performance utilising machine learning methods is a recognised probability field involving computational learning algorithms (Garg, 2013). It is undertaken through the implementation of a software programme to evaluate the factors of a defined method. This model can make predictions according to descriptions of knowledge data or features. The two main factors needed to achieve the machine learning method are, (i) the problem should be able to be solved by an efficient algorithm for processing, and (ii) trained data needs to be represented in an efficient way for inference (Ayodele, 2010). Machine learning algorithms can be categorised into three common types, namely, supervised, unsupervised and semi-supervised.

## Literature Review

**Supervised Learning:** these types of machine-learning methods can be used to generate the algorithm depending on the training data, where input (features) and output (class) are labelled.

**Unsupervised learning:** these types of machine learning methods can be utilised to provide output without telling the computer what the input data is, where the input features are not labelled to generate a function.

**Semi-supervised learning:** these types of machine learning methods can be used by combining both methods, labelled and unlabelled, to produce an appropriate decision.

The features of any data require an appropriate method of training and validation to achieve a successful outcome (Larson, 1931). This can be done through using cross validation to test the method, in order to determine whether there are any new data which can provide the best estimation performance (Mosteller & Tukey, 1968). In order to do this, the data are divided into two parts, one for testing and the other for training (Arlot & Celisse, 2010). The most well-known cross-validation methods and holdout (percentage) (Damopoulos et al., 2012), k-fold cross validation and leave-one-out cross validation.

- **Holdout Method**

The holdout (percentage) method is the simplest type of cross validation, where the context data are divided into two groups, 66% for the training set and 34% for the test set (Damopoulos et al., 2012). This method has been utilised for training data in the evaluation to estimate the error rate of the trained decision-making classifier.

- **K-Fold Cross Validation**

The second method is k-fold cross validation, which is a development of the percentage split (holdout) method. The algorithm randomly splits the data into k equal folders, and each time one of the k-folds is used as a sub-test and the other is used as the training set (Schneider, 1997).

- **Leave-One-Out Cross Validation**

The third method is leave-one-out cross validation. This is created from the k-fold approach, where the number of instances is equivalent to the number of k-folds. This method is used for training on all of the data set excluding one fold; it gives good results but requires many computations (Tapia, Intille, & Larson, 2004).

## Literature Review

The Weka open source tool has been widely used for machine learning in the last two decades for real-world datasets. It was produced by the University of Waikato in Java code by Bouckaert et al. (2010), and has been utilised and downloaded by approximately 1.5 million researchers since April 2000 (Group, 2007). It has been employed by many authors from different information environments such as websites classification (Mohammad, Thabtah, & McCluskey, 2014); context-aware location of smartphone users (T. Anagnostopoulos, Anagnostopoulos, Hadjiefthymiades, Kyriakakos, & Kalousis, 2009; Saeedi, Moussa, & El-Sheimy, 2014); energy usage in a smart home (C. Chen, Das, & Cook, 2010); and context-aware recommender systems (Zheng, Mobasher, & Burke, 2014).

Weka classification of the context-aware database involves the Weka software tool (Version 3.8), which permits the implementation of frequent prototypical training by different machine learning models and the use of standard performance-testing methods such as 10-fold cross-validation and percentage split. It has been utilised to perform decision-making classification of a database history using Naïve Bayes and Decision Tree as ML algorithms. Both algorithms were utilised to train and test a method using 10-fold cross-validation and the holdout method, also called percentage split. The best-known evaluation method is called K-fold cross-validation, which has been used in many research studies to produce accuracy, F-measure, recall and precision in machine learning algorithms, especially for decision making or classification (Bin Abdullah et al., 2012). Another study by Isinkaye, Folajimi, and Ojokoh (2015) has provided training instances utilising the Naïve Bayes classifier to design an intelligent agent for the purpose of anticipating user interest in web pages. The computation process was carried out using Microsoft Visual Studio 2012 Professional (Garg, 2013) for implementing the NBC algorithm, and Weka 3.7.6 for the feature selection process (Hall et al., 2009).

### **2.11 The Smart Home Growth Rate and Challenges for an Ageing Population**

Life expectancy in many countries is rising (Oeppen & Vaupel, 2002). As a result, many people live for long periods with illness or disabilities. In recent decades, there has been an increasing amount of literature on the subject of healthcare applications and ‘well-being monitoring’ (Alemdar & Ersoy, 2010; Majeed & Brown, 2006), which is designed to

## Literature Review

regulate the well-being of aging people and assist them to perform their daily activities securely and safely (Gaddam, Mukhopadhyay, & Gupta, 2011; Suryadevara, Mukhopadhyay, Rayudu, & Huang, 2012).

There is a growing number of older people in the general population, the majority of them women, who live independently, or as independently as they can. They are often affected by sickness or disability and there is a movement by both official bodies and private companies to install methods of monitoring people who are at risk (Chan, Campo, Estève, & Fourniols, 2009). This means there is a need for new technology and new tools which can help people to live independently and still enjoy safety and comfort in their home.

The ageing population has continued to grow since 1950; the world percentage of elderly people has increased steadily from 8% in 1950 to 11% in 2009 and is expected to reach 22% by 2050. It has been noted that the continuing decrease in mortality rates for the elderly means that the proportion of older people in the population will continue to increase (Economic, 2010). In recent years, there has been an increasing amount of literature on life expectancy in developed nations.

For example, Dunstan and Thomson (2006) a study from New Zealand reveals that at present the N.Z. population aged over 65 has risen by 44% since 1970. In 2005 it stood at 500,000, and the study estimates that the over-65 populations will increase by 87% to 1.33 million between 2005 and 2051, with the greatest growth expected between 2021 and 2031. Elderly people are therefore the fastest growing segment of the population in developed countries, and they desire to live as independently as possible, but independent lifestyles come with risks and challenges. Tele-monitoring in the home is a solution to deal with these challenges and to ensure that elderly people can live safely and independently in their own homes for as long as possible (Medjahed et al., 2011). Indeed, it is now widely known that embedded sensors and actuators within mobile computing in the smart home can be useful in improving elderly people's daily lives (Medjahed et al., 2011).

There are some challenges to living in a smart home, however, especially for those in old age. These include, for example, cost, confidentiality, accessibility and confidence (Lê et

## Literature Review

al., 2012). The risks of the smart home amongst residents also include ethical matters, technical suitability and psychological acceptance. Certain recommendations and plans have been suggested for households in which older people will require a certain level of technological know-how. It is recommended, therefore, that there is a need, through preparation and discussion, to research and ascertain relevant information about requirements in the lead-up to implementation for residents. Financial support will be paramount and there will need to be a funding process in place for the elderly to buy equipment which will have a potential impact on not-for profit organisations in particular. Moreover, further study is required to help elderly people access, recognise and become comfortable with the relevant appliance technology. Indeed, smart home technology must be acceptable on many levels if it is to be of general help to society.

For challenges in the smart home, more details can be found in a review study by Rodgers, Bartram, and Woodbury (2011), whose investigation about challenges in sustainable homes concentrated on smart automation and related performance, such as use of lighting and appropriately arranged and organised settings for home devices. They employed the Aware Living Interface System (Damopoulos et al.) as a framework that supports daily activity, awareness, and control system design in dwellings. However, the results show that the functions of this prototype in the smart home will need to improve and provide a better design and interface for different disciplines including government services, ICT, Home Computer Interaction and service providers. Moreover, using equipment in the smart home is often complex (Saizmaa & Kim, 2008) where features affect social life, psychological and physical necessities. One of their findings is that smart home technology may be suitable for technical applications, but the resident interface is not very user friendly.

### 2.12 The Concepts of Home Automation

- **Recognition of residents**

The first concept to be considered is how to recognise the inhabitants in the smart home. In order to create decisive and comprehensive automation, it is very important to know whether the room is occupied. Depending on the situation, it may be necessary to monitor the house using sensors to track the human body in real time,



## Literature Review

considering for instance obstacle-avoidance sensors, human body sensors and distance sensors. The main function of these sensors is to discriminate between the residents occupying or not occupying rooms. It is essential to have prior information that occupants are in a specific room to make the appropriate device active. This can be done according to high statistics computation using the search engine EF-ICF-IF.

- **Automation of locale setting**

While the dwelling is occupied, the comfortability service should be assessed by examining the home environment. These conditions can possibly be determined from sensors, including a temperature sensor, brightness sensor, humidity sensor, smoke sensor and sound sensor. The information in the smart home can be gathered from the input of each sensor and by equipping the environment with different electrical appliances such as fans, LED lights and audio sources which are fitted with a wireless adapter, typically employed with an embedded system. These devices can take action automatically according to collected data by using the Naïve Bayes decision-making method. The proposed controller model needs to identify and predict which of the devices should be switched ON or OFF depending on data acquisition.

### 2.13 Problems Identified

As shown in the sections above, there have been a large number of studies into context-aware computing and mobile systems, and further research continues to be carried out in many relevant areas. Such research is mostly at an early stage and still limited by technical difficulties. The chief problems which have been observed regarding context-aware systems based on mobile devices and machine learning are as follows:

- The variety of techniques and lack of basic similarity in architecture support. Mobile devices, wireless infrastructure and techniques of sensing data are numerous and varied. This creates difficulties in gathering context-aware data, demonstrating it and distributing the data among the functions of the various devices in a context-aware system. The basic general architecture is intended to manage these difficulties. However, it has not yet developed sufficiently to be

## Literature Review

able to compensate for all these problems and cannot yet provide the precise and comprehensive supervision which is needed.

- Unobtrusive data abstraction using mobile and embedded sensor devices has limited resources to deploy. It can be difficult to obtain context data in certain circumstances and it is difficult to achieve consistency and reliability using devices with few resources in a wireless environment. The devices can be overloaded and the amount of data can over-complicate their action. The ultimate aim of developing a context-aware system is to ease normal human activities. It is extremely important to develop equipment for gathering and abstracting context-aware information which is usable in every-day circumstances. It must be portable, quiet and small if possible or at least easily placed in a house, as well as efficient.
- The necessity for good quality supervision of computing decision making by the computing service in most context-aware systems relies on uncomplicated logic and rules. However, these rules may have to be based on a great deal of consideration and careful definition. Present methods are particularly inefficient in the complex area of relating context information to the best computing source for the purpose.

### 2.14 Summary

This chapter has outlined the published literature relevant to the use of prototype systems for context-awareness in the smart home. These studies have considered developing technologies and how they will improve the living environment facilities of the occupants, as well as how they can be more helpful and reliable for them in the future. Mobile computing services in a smart home using context-awareness for smartphones and their applications have been presented.

The beginning of the chapter has provided context-aware definition, a short description of the use of smartphones and wireless sensors involved in developing a smart home, followed by a review of context-awareness based on monitoring elderly people and their needs. Here some theories related to context-aware systems have been considered, as well as different

## Literature Review

applications of context-awareness in the home environment. In addition, this chapter has included potential models for activity monitoring and control in the smart home environment in the last decade. These models use statistically-based rules, such as a TF-IDF search engine. This works as a weighted method and the Naïve Bayesian classifier is used as a decision-making algorithm.

Finally, the chapter has presented a review of the various technologies and developments that have been involved in the use of household networks and services to improve quality of life and enable people to live alone. In integrating these technologies, there clearly remain some core difficulties, and the challenges of an ideal smart home have become more complicated with regard to identifying needs. The aim that follows is to develop simple and more effective ways of providing easy-to-use devices that are easily integrated within the life and capability of an elderly person, in terms of both the equipment and the service interface for the elderly user. The next chapter will describe the design of a prototype system; this prototype includes low cost sensors with their functions, actuators, a wireless adapter, embedded system and a smartphone.

## **Chapter 3 The Design of the System Architectures**

This chapter is divided into two main sections. The first section describes all the necessary devices related to a proposed system design for Wireless Sensor Actuator and Smartphone in the Smart Home (WiSAMCinSH), as well as the methods required for dealing with context-aware automated services. The prototype system includes eight sensors with different functions, actuators, a wireless adapter (Wi-Fly), a microcomputer unit and a smartphone. The smartphone is utilised to gather context information from the home environment, as well as being an application interface to interact with the inhabitants and functioning as a means of both monitoring and controlling home devices. The second section considers the general design of this prototype system for smart home services, before an evaluation is carried out by testing the system through two experimental studies.

### **3.1 Architecture Design for General Prototype Model**

A sensor is an important appliance which is used to transfigure physical actions and convert important quantities into electrical raw data. The sensor data must be adjusted and then transformed into digital form, after which they are transferred into the embedded system for additional processing. There are various types of sensor, some of which can be integrated with a pervasive microcontroller unit (STC MCU, 2011) to enable exchange of information and interconnectedness. This allows the programs and operating information used by a computer to send the information wirelessly to other places. There are also other types of sensors that are not integrated with an MCU, and these can be used according to their functions.

Nowadays, some goods are already integrated with sensor elements which can afterwards be connected to a wireless network to provide observations about their settings, thereby giving information related to the environment of the equipment and the situation of its user. Most sensors in domestic appliances are designed to be wireless connected and are inexpensive, and there is great demand for them to be used with actuators for several applications in smart home circumstances (S.-F. Li, 2006a). The previous studies mentioned in Chapter 2 suggest that different types of sensors and actuators should be involved in the

## The Design of the System Architectures

prototype system. Sensors which can be used to obtain a context from the environment of a smart home with embedded systems include obstacle avoidance sensors; smoke sensors; human detection sensors; brightness sensors; temperature sensors; sound sensors; ultrasonic distance sensors; and humidity sensors. Ding et al. (2011) used a survey to assess the effect that various sensor technologies have on sensing environments and infrastructures mediated in the smart home. For elderly people, these are often wearable sensors in clothing which are then connected up wirelessly to the home infrastructure (Ding et al., 2011).

The system architecture from the communication, electronic devices and data management viewpoint is given in Figure 3-1. The main aim of this function is to transfigure physical variables in the real environment into digital variables, which are processed in the computing system. The acquisition of this type of context will need features such as a wireless adapter, sensors, embedded systems and the end user, who is the client.

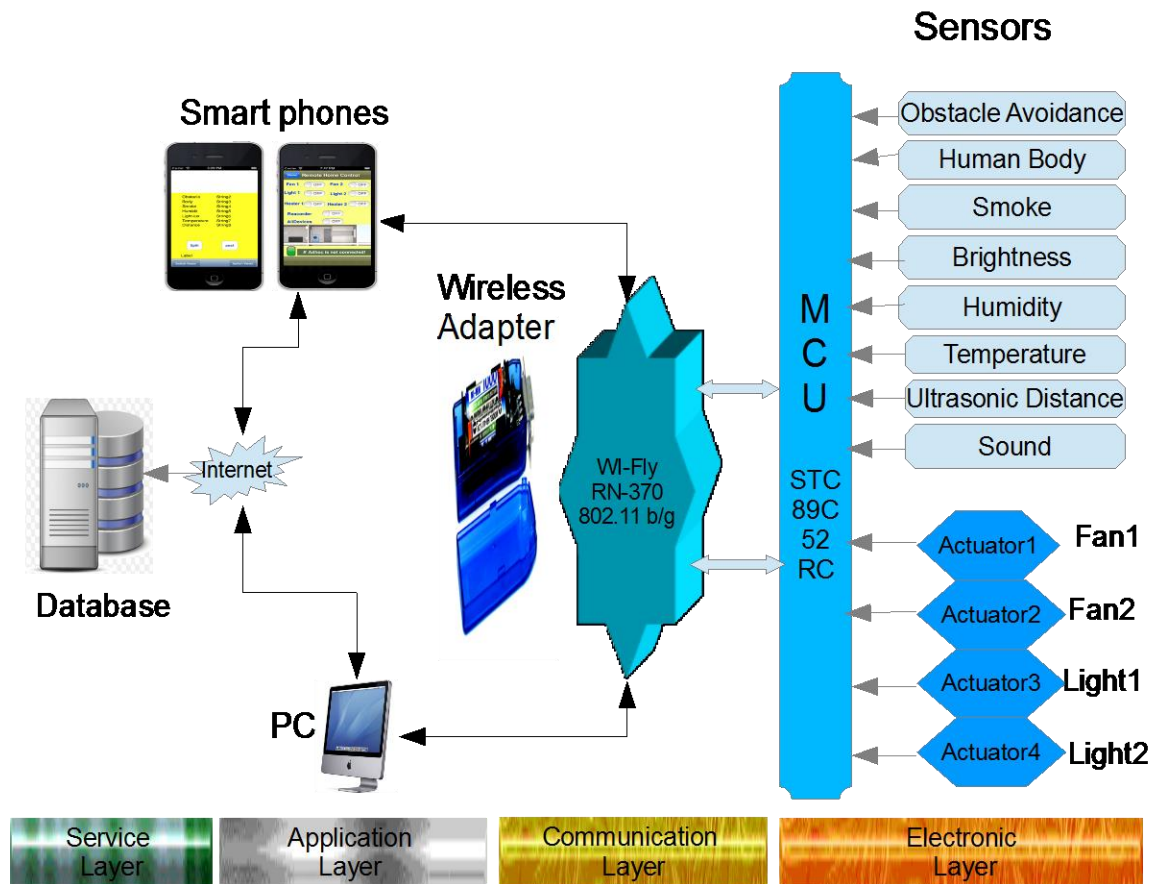

Figure 3-1 Framework layers in the WiSAMCinSH system

## The Design of the System Architectures

### 3.1.1 Design of sensors

There is a significant need for the use of sensors for several applications in the prototype. The most commonly used are identified in Figure 3-1 above, which lists the different types of sensors that have been used in the system design.

The function of the temperature sensor DS18B20 (Maximintegrated., 2008) is to gather data from the room environment when the software program runs in the MCU. The obstacle avoidance sensor E18-D50NK has a detection distance of between 3cm and 80cm, with an adjustable resistor, while the human body sensor DYP-ME393 reliably detects the human body when it comes to within seven metres of the sensing area. The last sensor is the ultrasonic distance measuring HC-SR04 (Technologies, 2012), used to measure distances from 2cm to 4m when the function is working well. Implementation of the prototype system firstly requires connection of the eight types of sensors to the MCU.

Each sensor has three pins: one for power supply connected to the VCC (4.5-5V), one for ground (GND) (0V) and one for the output signal. The sensor pins connected to GND, OUTPUT and VCC are shown in Figure 3-2. Some sensors work by automatic sensing, for example, the obstacle and human body sensors, where high voltage will be released when the human body reaches the sensing area and switched off when the body leaves the sensing region. The specification parameters of the sensors used for context-aware information in this system are given in Appendix B, Table Ab-1, and images of the sensors utilised in the design of this experiment are shown in Figure 3-3.

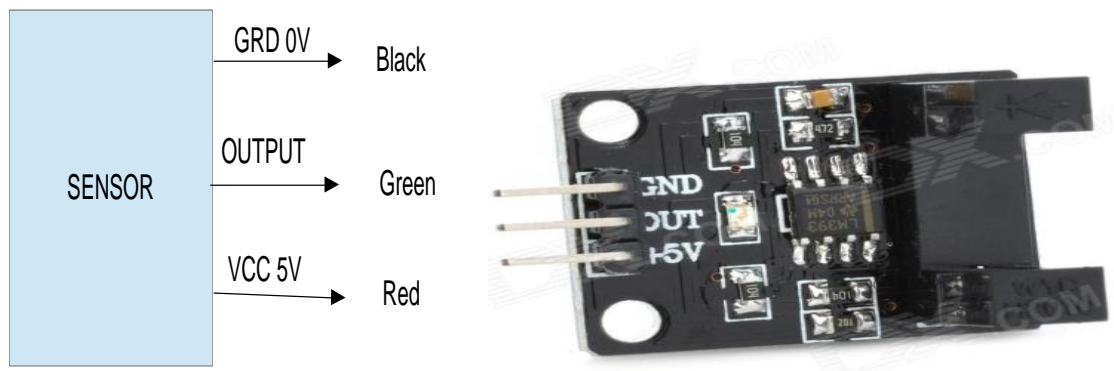

Figure 3-2 Sensor pins connected to GND, OUTPUT and VCC

## The Design of the System Architectures



Figure 3-3 Smart home sensors design

### 3.1.2 Obstacle avoidance sensor

The obstacle avoidance sensor has an output signal which varies according to when a human body arrives close to the object's sensing zone. A high voltage will be released (1 volt) when the human body reaches the sensing area, and switched off (0 volt) when the body leaves the sensing region. The output signal is shown in Figure 3-4.

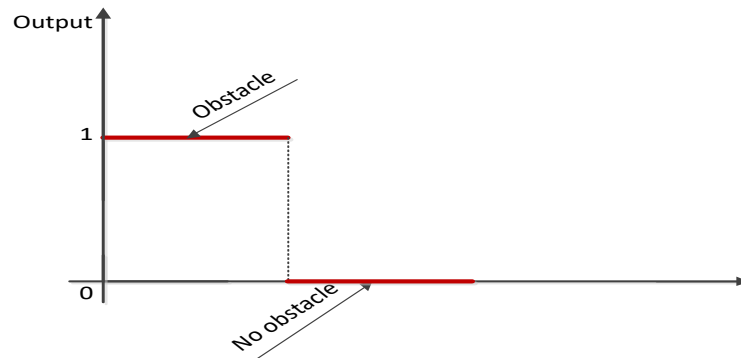

Figure 3-4 Obstacle avoidance sensor output signal

## The Design of the System Architectures

Notes: The human body sensor, smoke sensor, humidity sensor and obstacle avoidance sensor all have the same output signal (0 and 1 volt).

### 3.1.3 Ultrasonic distance measurement sensor

The ultrasonic distance measurement sensor is used for obstacle detection and computation of its distance from the visual object. The sensor contains an ultrasonic transmitter and receiver circuits. The model has a range of up to 4m for accurate measurement, and triggers 10uS at high level, as shown in Figure 3-5. Figure 3-6 illustrates the measurement angle and sensor performance within 30 degrees. For distance calculation, the following equation is used:

$$\text{Distance} = (\text{time} \times \text{speed})/2 = ((\text{TH0} * 256 + \text{TL0}) * 2.45) / 100 \text{ (Technologies, 2012).}$$

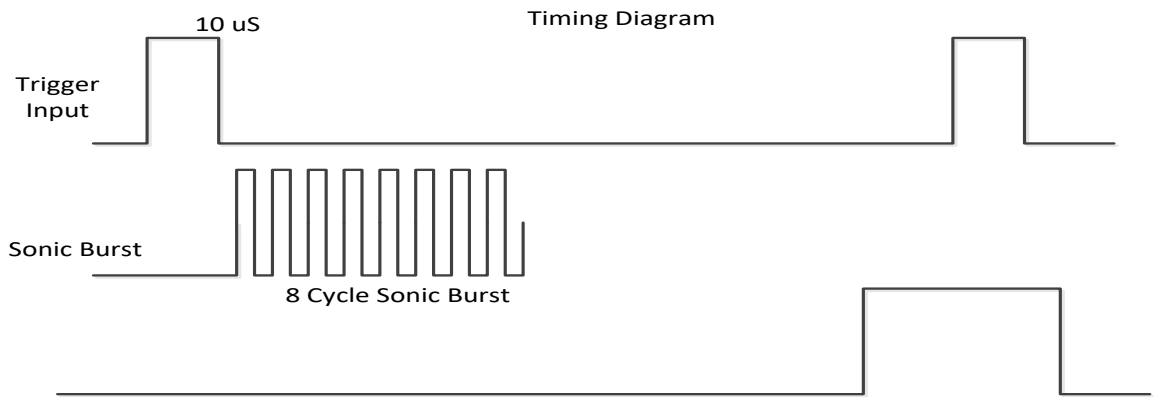

Figure 3-5 Time diagram for ultrasonic distance measurement sensor (ElecFreaks, 2014b)

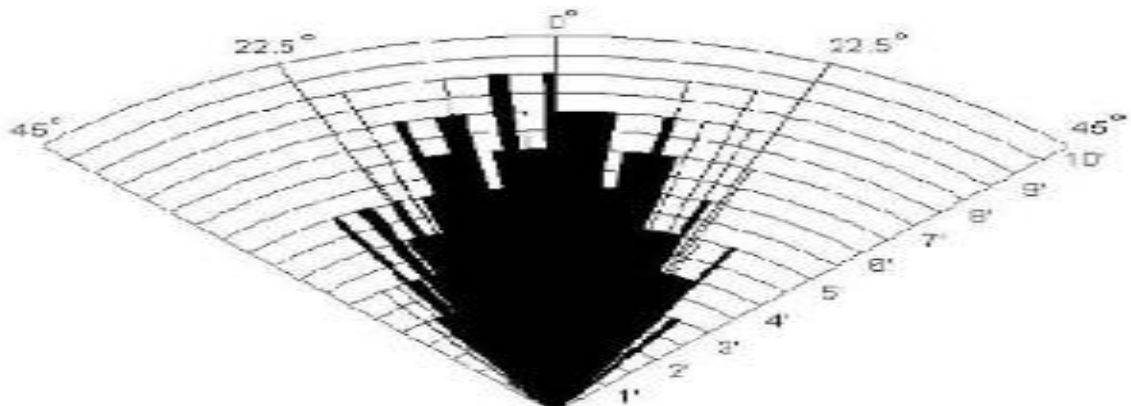

Figure 3-6 Measurement angle and performance within 30 degrees (Kuantama, Setyawan, & Darma, 2012)



### 3.1.4 Light sensor

The light sensor is a digital brightness sensor suitable for ambient light, and has the ability to detect a high resolution at long range from 1 to 65535 lux. It can respond to different sources of light, for example, lamp, fluorescent, sunlight and white LED. The time pulse starts after the DVI rises to  $1\mu\text{s}$ , when the voltage supply switches on, and the output time is illustrated in Figure 3-7.

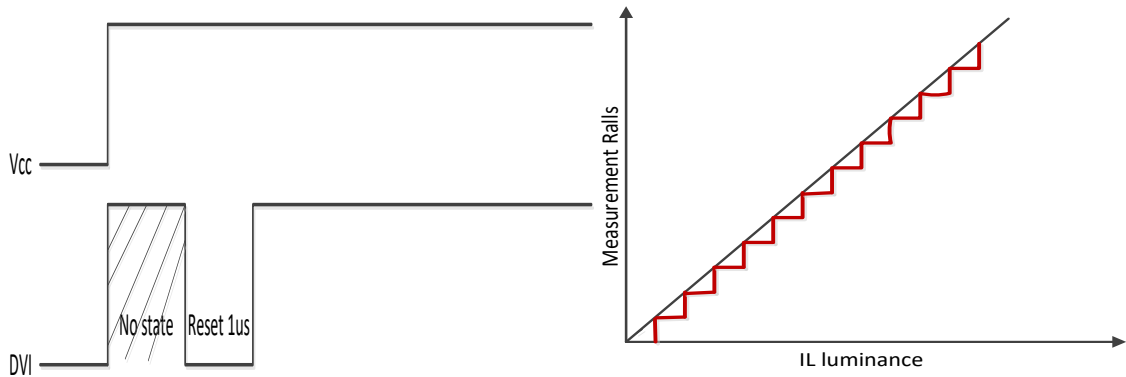

Figure 3-7 (a) Time diagram for VCC and VDI voltage supply; (b) Luminance measurement results

### 3.1.5 Temperature sensor

The temperature sensor can be used to measure the temperature in the home environment. It uses discrete repetitive and continuous signals rather than a digital signal (0 and 1). The DS18B20 sensor communicates over one-wireless access with an embedded system using one-row data, as shown in Figure 3-8.

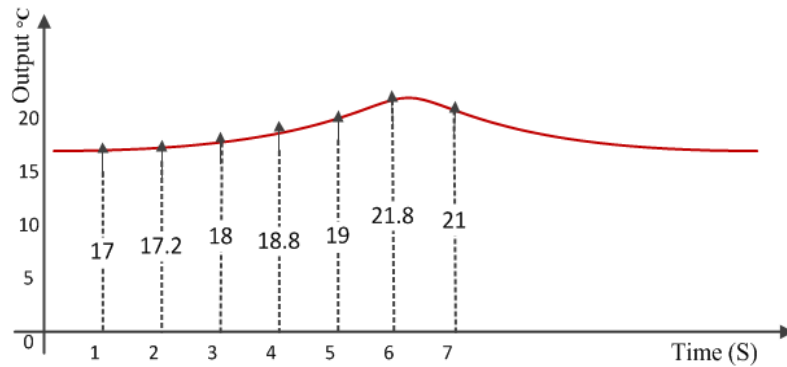

Figure 3-8 Temperature sensor DS18B20 output signal

## The Design of the System Architectures

### 3.1.6 Human body sensor

With the HC-SR501 human body sensor, the person's body is sensed when it appears within a range of seven metres of the sensing area. The output will turn to a high voltage '1' from low voltage '0', as shown in Figure 3-9. This feature can be realised by the wireless adapter and embedded system, which are the link between the sensor and the end user via a smartphone, tablet or computer. This information is transferred from the sensor output via wireless node.

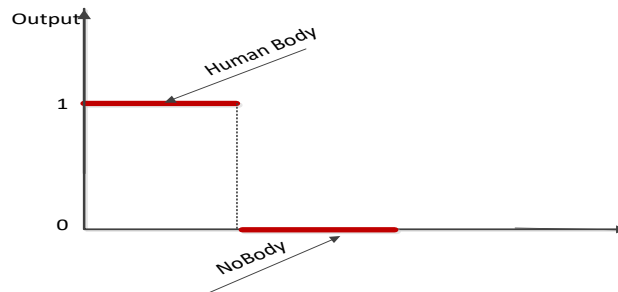

Figure 3-9 Human body detection sensor output data

### 3.1.7 Smoke sensor

The MQ-2 smoke/gas detector sensor is used to provide early warning of fire and smoke in the smart home environment. This type of smoke detector works by using the principles of different processing methods to sense the visible and invisible. The sensor has high sensitivity to gas detection, and the output signal of the MQ-2 provides low-cost knowledge of carbon monoxide and smoke impurities that can be read online for gas monitoring in the context-aware environment. It is also more adept at detecting some types of gas mixture than other sensor technologies that are commercially available (Nogales, Agbay, Flores, Manuel, & Salonga, 2014).

### 3.1.8 Humidity sensor

The signal output of the humidity detection sensor (HR202-LM393) is illustrated in Figure 3-10. This sensor has been used on different occasions and in a variety of places, such as in factories, clinics, textile manufacturing, the tobacco industry and by chemists, as well as for monitoring the home environment. When the humidity is high, the output sensor will turn

from '0' to '1', but when the humidity is at a low level the output will trigger from '1' to '0'.

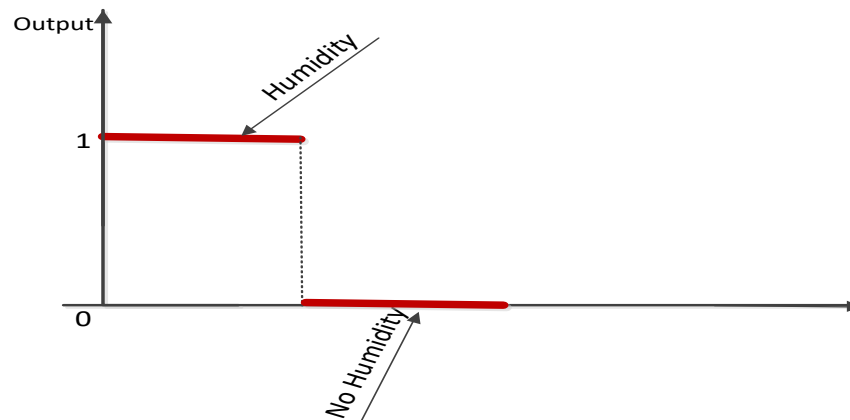

Figure 3-10 Humidity detection sensor output data

### 3.1.9 Sound sensor

This sound sensor (CZN-15E) is based on microphone detection of sound with a changeable potentiometer to regulate the trigger level. Its output signal is binary; if the value of sound is high, the output will go to '1', but if the level of sound intensity is low, this will trigger to '0'. The value on the serial monitor varies depending on the sound volume according to the power amplifier. The sensor proceeds to send an output voltage to a microcontroller, which subsequently performs any processing. This component offers an easy method of sensing voices and is commonly utilised for identifying sound strength. It can also be used for other functions, such as security detection of gas leakage based on an audio technique (Santos, de Sousa, da Silva, da Cruz, & Fileti, 2013), as well as for monitoring the home environment.

### 3.2 Relay (actuator) function

An actuator (SRD-05VDC-SL-C) is an electrical device used to control electronic appliances by opening or closing the switches of other circuits. It has an electromagnetic coil to operate the switch for two positions, ON or OFF. It is activated by a signal or electric current that flows through the coil, and as a result, the magnetic field attracts an armature. Once the current to the loop is interrupted, the magnetic force is reduced, which causes the armature to return to its relaxed situation. This actuator is designed to be operated with DC

## The Design of the System Architectures

voltage and other specifications as mentioned in Table 3-1. It includes a diode on the coil, which are installed together to prevent the magnetic field from disappearing. Most actuators are designed to trigger as quickly as possible to achieve the desired actions, and therefore a relay is required. A relay is a kind of small electrical engine (motor), which is responsible for controlling electrical machines by transforming electrical energy into dynamic motion. Figure 3-11 shows the relay device used in this research in connection with other electrical and electronic devices in the lab (Ghabar & Lu, 2015).

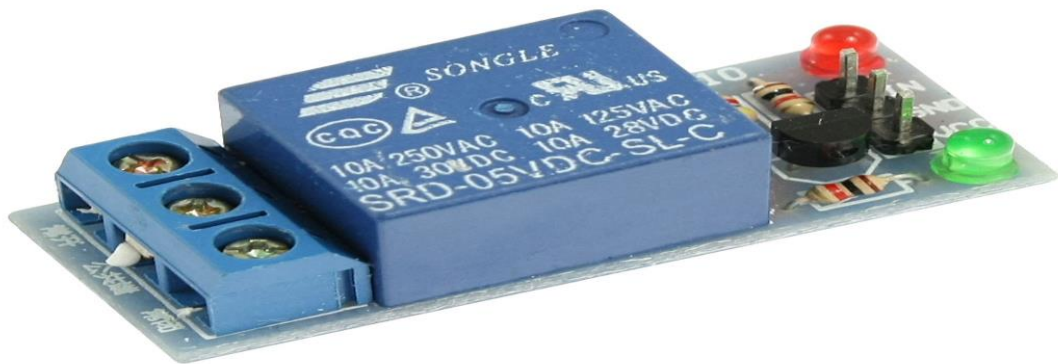

Figure 3-11 Relay (RSD-O5VDC-SL-C)

Table 3-1 Relay specifications

Product Name	Low Level Relay Module
Relay Type	SRD-05VDC-SL-C
Coil	5V DC
Load	10A, 30V/28V DC, 125V/250V AC
Size	1.6*0.7*0.6(L*W*H)
Main Colour	Blue
Material	Plastic; metal electrical parts
Weight	15g

## The Design of the System Architectures

### 3.3 Microcontroller unit (logic converter)

The automated home system gathers data from the sensors, pre-processes it and sends it to the phone, and then the microcontroller connects to the computer. A wireless module, Bluetooth, Wi-Fi or ZigBee, is also connected to enable the wireless connection through the server. The STC89Cxx series MCU is a vital element of the system which is to be used (STC MCU, 2011). It is an 8-bit single-chip microcontroller and integrates with the outlying communication devices that monitor the environment, collecting data about the human body, obstacles, temperature and humidity, brightness and the presence of smoke. The chip can store data in its 64k bytes of flash memory. It has a Wi-Fly wireless transceiver as an interface and uses In-system Programming (ISP) and an In-System Application (ISA) to assist users by sharing the data.

A Universal Asynchronous Receiver Transmitter (UART) must be used to supply these communication needs. The UART is a device for receiving and transmitting raw information (STC MCU, 2011). Large numbers of development tools are available if an MCU which supports low-level programming language C is used (see Figure 3-12) (Ghabar & Lu, 2014).



Figure 3-12 Microcontroller unit STC89C52RC

A brief comparison between various microcontrollers is provided in Appendix B, Table Ab-2.

## The Design of the System Architectures

### 3.3.1 Embedded system connection with devices

The STC 89C52RC is produced by STC MCU limited. This is the most important unit for facilitating contact between the sensors and equipment which monitor a human occupant and his/her surroundings. It measures temperature and humidity and also collects data from other sensors, interacts with the Wi-Fly adapter and uses its memory for data storage. This type of MCU has been laboratory tested using eight different sensors. Figure Ab-1, in Appendix B, illustrates the simple stamp microcontroller and Figure Ab-2 shows the actuators connected to electrical appliances.

### 3.4 Wi-Fly wireless transceiver adapter (RN-370)

The Wi-Fly (RN-370) wireless adapter uses an external AC-5DC (two AAA batteries); this will last for eight hours when completely charged. It connects to the RC-232 serial port interface by means of a DB9. The data from the sensors travels via the MCU and is sent to the end device, for example a PC or iPhone. Information can also be sent via a dependable TCP/IP socket (Networks, 2010), which can use either an information network or an ad-hoc network. This has the advantage of low wireless construction and adaptability as it can be used with any Wi-Fly serial adapter. Figure 3-13 illustrates this arrangement. (Ghabar & Lu, 2014).

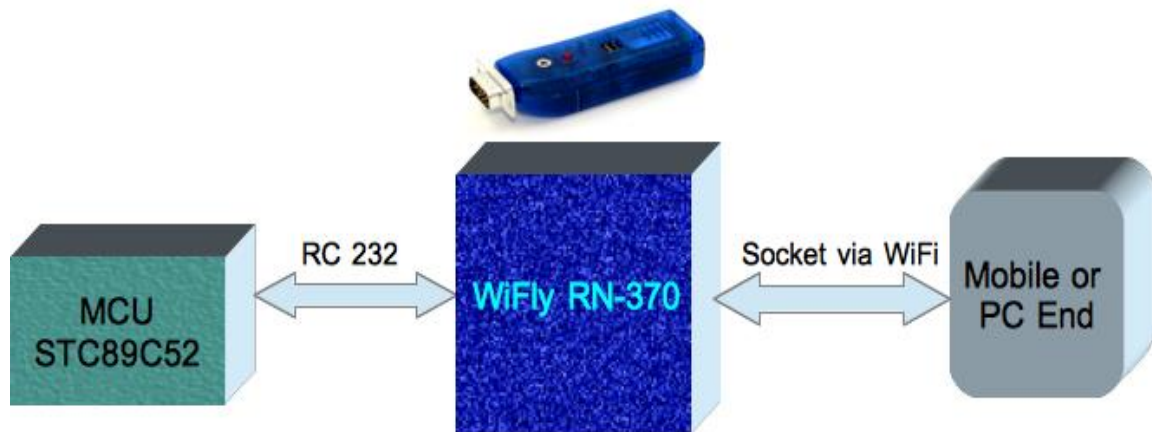

Figure 3-13 Overview of the Wi-Fly RN-370 adapter configuration

There are different types of connections accessible to construct Wi-Fly applications, for instance monitoring environment, control of appliances, diagnostics, and mobile phone

## The Design of the System Architectures

connections via GPS. The wireless configurations can be set as peer-to-peer (ad-hoc) networking to an iPhone by using an IP address (169.254.1.1) and subnet mask (255.255.0.0), with the need to set the Service Set Identifier (SSID) and Wi-Fly-GSX21 in a wireless mobile computing network (Networks, 2010). However, some wireless technologies require more complicated processes to connect to low-cost, power parameter sensor devices.

### 3.4.1 The Wi-Fly serial adapter (RN370)

The Wi-Fly serial adapter was the last device to be tested in the experiment. This interfaces with the MCU by means of a DB9 pin connector through serial communication port RC232. This works by means of an input power supply from 4.5 to 5.0 VDC. Three cable interfaces (RXD, TXD and GND) connect the Wi-Fly and the microcontroller, or five interfaces between the Wi-Fly and computer (See Appendix B, Table Ab-3) (Ghabar & Lu, 2014). Wi-Fly adapter RN323 was used for this research, as it can be conveniently adapted for communication use by a wireless LAN, especially for communication between the MCU and other appliances in the same network, such as a computer or a smartphone like the iPhone 5S.

### 3.5 Smartphones and PCs (end users)

It is envisaged that, using this system, the person concerned will use a smartphone such as the iPhone 5S as the platform. This will collect information from the sensors and allow control of the actuators. In the prototype system, the smartphone platform is programmed using Object-C as a means of communication via CFNetwork sockets (see Figure 3-14). Zdziarski (2009), has devised a code which uses a CFNetwork socket to join iPhone and web server, or for use with peer-to-peer networks, for example an ad-hoc connection. (Ghabar & Lu, 2014).

## The Design of the System Architectures

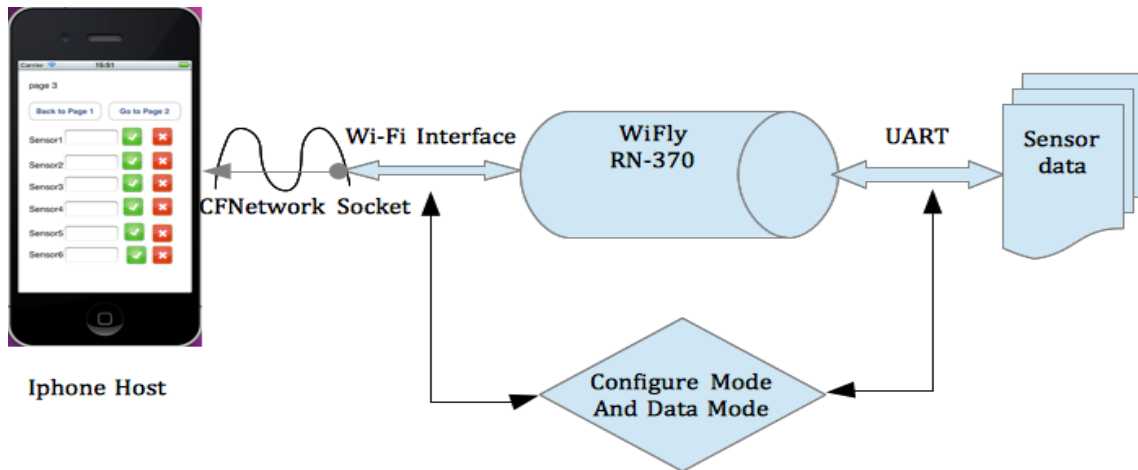

Figure 3-14 End-user connection between Wi-Fly and iPhone 4

### 3.6 Design of the General Prototype System

#### 3.6.1 Context-aware smart home automation prototype

The aim of this section is to explore whether the results of studies found in the literature can be applied in practice by concentrating on a specific area, such as the smart home. The acquisition of context information is essential to prototyping and building a model for a context-aware smart home system. The context data needs to be categorised into various classifications, and the methods of collecting the context information must be illustrated. The system design should also be adaptable to enable the control of context supervision. The information and technologies of a prototype system should be joined together to provide flexibility and reusability. In this study, a categorised system design is planned relative to smart home automation and the control of context data inflow within the system. As shown in Figure 3-15, there are five layers in the prototype architecture: a physical, device service layer; a communication layer; context data processing layer; database service layer; and intelligent decision-making layer.

The researcher trusts that any restrictions of this prototype system will be negated by the benefits of being able to create interfaces that can be personalised to operators and the instruments they choose to use. Working on developments to the prototype will ensure that



## The Design of the System Architectures

newly created interfaces take into consideration any previous interfaces with which the user has interacted.

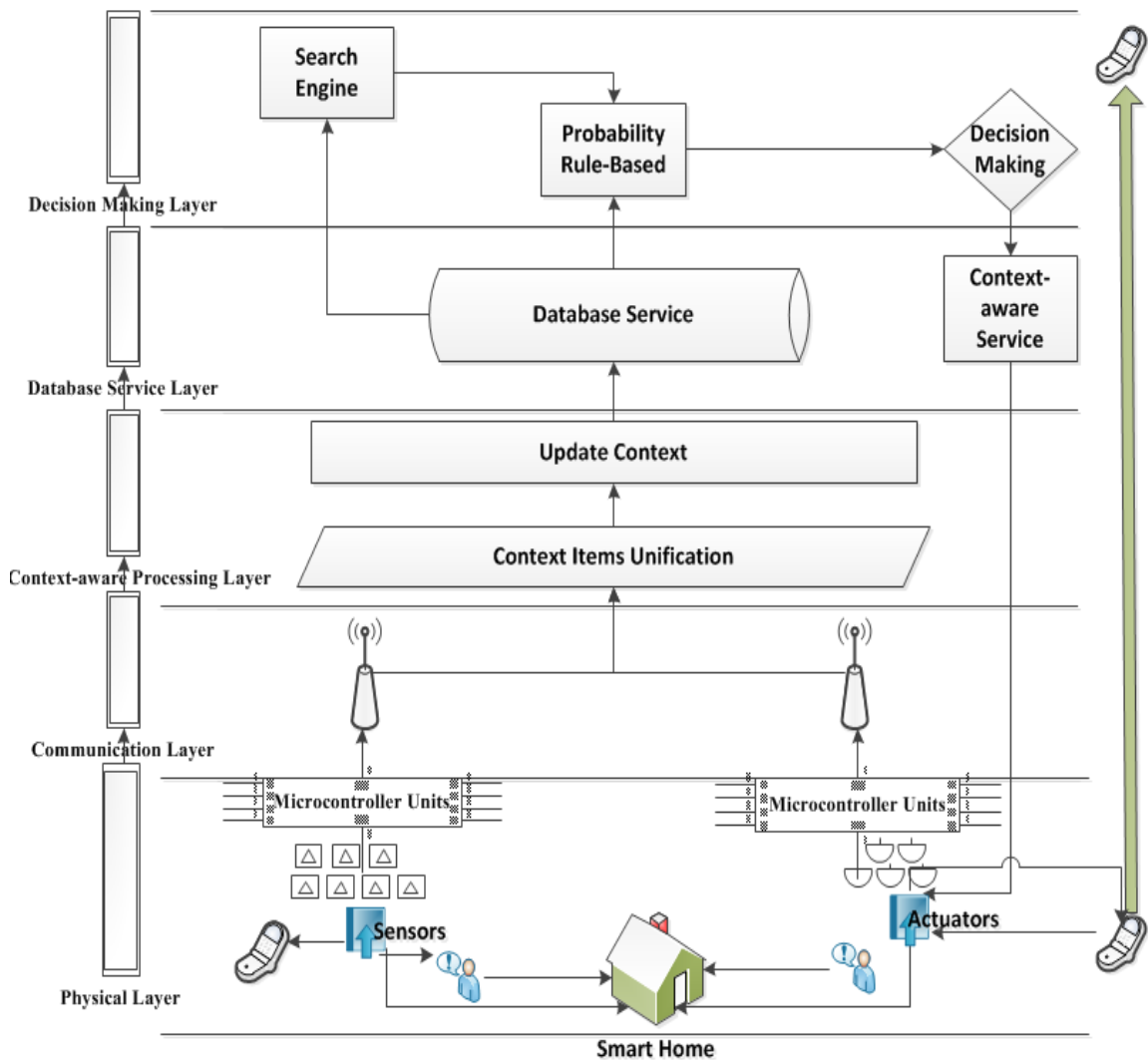

Figure 3-15 Comprehensive plan of the system architecture in a automated smart home service

### 3.6.2 Physical layer

The physical layer is the physical crossing point between the real-world environment and the computer unit system. This is essentially the context of the fundamental layer of hardware for electronic sensors and executing commands. Items in the physical layer are a

## The Design of the System Architectures

person, the environment, the sensors and actuators. The aim is to decrease the workload of inhabitants and to regulate the applications. Some features related to the physical layer are:

- Services provide automated and even intelligent computer-based control;
- Sophisticated systems and the technology used are unseen by the inhabitants;
- New sensing technologies are involved in the creation of new features.

This level consists of specific implanted microchip technology required to transform the digital logical form, organise certain pre-processing tasks and create the information format. Techniques like the wireless electric plug and Analogue to Digital Converter (ADC) are required to gather sensory information, transform the physical data, and communicate accordingly.

### 3.6.3 Communication layer

The communication layer sends information from the various centres to whichever applications are needed for the purpose. This layer not only sends information as already described, but also sends the user's requirements to the electronics section and sends data to the successive interfaces, such as the iPhone and computer controls. This information is sent through a TCP/IP socket where the network, whether ad-hoc or infrastructure, can provide wireless connection to several wireless adapters (Ghabar & Lu, 2014).

### 3.6.4 Wireless connection of actuators and sensors

It is necessary to design and implement systems which are as economical in cost as possible. In addition, the means of connection and communication must be selected to enable maximum flexibility for the user. The Wi-Fi network is generally available, so it has been used for connection between the electronic devices. Sensors and actuators are joined by wireless communication to collect sensor data and to carry out the control actions. The RN 370 wireless adapter module upholds both ad-hoc and infrastructure modes of networking, and the user interacts with the system using his/her personal smartphone. The elements needed for the prototype system can be found in Table 3-2 (Ghabar & Lu, 2015).

## The Design of the System Architectures

Table 3-2 Electronic appliance engagement (Ghabar & Lu, 2015)

Appliance Employed	Appliance Models	Functionality
Smartphone	iPhone 4	Receives the gathered information from sensors and controls the actuators
Actuators	Relays	Switch on or off
Sensors	Temperature, Brightness, Smoke, Sound, Humidity, Distance, Human Body and Obstacle Avoidance.	Gather data from home environment
Wireless adapter	Wi-Fi RN-370	Transfers information, written or read, to the successive interface
Embedded system	MCU-STC89C52RC	Collects data from sensors and pre-processes raw data
Wireless access point	Chortle (Cisco Aironet 1100)	Wireless network
Home automation	Fan and light	Cooling and brightness

In Figure 3-16 the wireless adapter and smartphone appliance are integrated through a Wi-Fly access point for different functions such as context updates for monitoring and context requests for controlling. The relay (or actuator) is responsible for the switching of context computing service for the control of smart home electrical devices. Meanwhile, the context information is collected and then transferred from low-layer to the high-layer via wireless networks. These steps can be adapted according to implementation of platforms and protocols. For example, communication between sensors to the embedded system using 1-wire, GPIO and I2C, embedded system to Wi-Fly adapter via RS-232 serial port, Wi-Fly adapter to remote control service and smartphone to Wi-Fly remote control service may all be achieved through HTTP request (UPDATE, GET, SPLIT, POST and SWITCH).

Similarly, smartphone to remote control server communication may be executed as shown below. The HTTP requests (UPDATE, GET, POST, SPLIT and SWITCH) are used as example requests as shown following:

## The Design of the System Architectures

- UPDATE

```
$result=$dbcon>httpUpdate($["sound"], $["brightness"], $_GET["body"], $["obstacle"],  
$["humidity"], $["smoke"], $["temperature"],", $["distance"], $["location"], $datetime);
```

- GET

For context-aware service request:

Set com remote GET\$/work2/HomeAutomation.php?

- POST

- (IBAction)postString:(id) sender

- SWITCH

- (IBAction) switchLedLightValueChanged:(id) sender

These methods, including the information transfers in the model such as context-aware information gathering and update, request, data split and remote control home facilities via smartphone device, are all implemented using the above functions (see Appendix A).

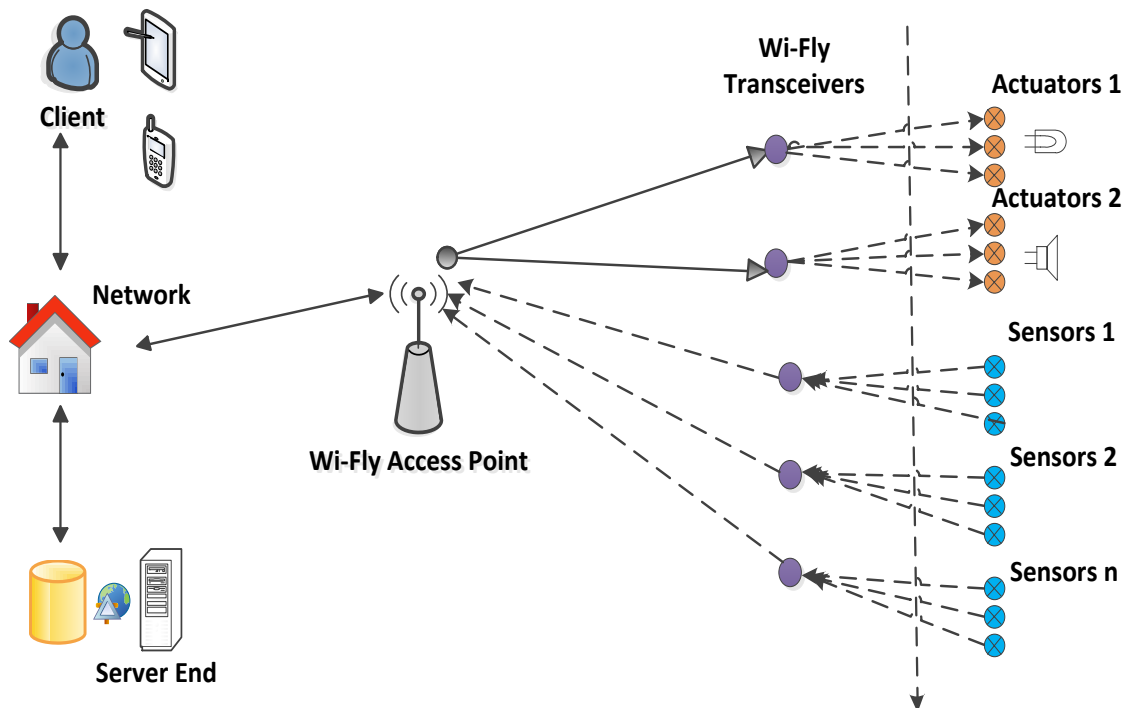

Figure 3-16 Wireless Network Communication of Smart Home Model

### 3.6.5 Topologies network configuration

#### 1- Ad-hoc network configuration

To configure the ad-hoc mode, the Wi-Fly adapter needs to be set up for the ad-hoc network within the hardware or software instructions. To permit the ad-hoc network to establish communication with a smartphone through hardware, switch 1 must be turned ON. Wi-Fly configurations can be set as peer-to-peer (ad-hoc) networking to an iPhone by using the IP address 169.254.1.1 and subnet mask 255.255.0.0, and setting the Service Set Identifier (SSID) and Wi-Fly GSX 21 for a wireless mobile computing network (EZX, 2011).

#### 2- Infrastructure configuration

Two commands for the wireless adapter must be designed and given to initiate the software of the infrastructure and to begin communication with the network. The first command will inaugurate an automated connection with a server; the second will produce automated tracking of the connection with the remote host (EZX, 2011). The Chortle series access point (1100) is required to connect the information network with the database server, as shown in Figure 3-17. The device will connect automatically when the local area network is established, using a Wi-Fly adapter. These commands are used for requests to the network and updates of the context (Ghabar & Lu, 2015).

**Step 1** – Set up the wireless communication for the local area network using a Wi-Fly adapter, and then the device will automatically connect to the network.

Context update to the network:

- (\$\$\$); type 3 dollar signs to see message with CMD command returned.
- Scan; scan available wireless network.
- Set wlan ssid chortle; ask to join the objective network.
- Save; save configuration.
- Reboot; restart.

**Step 2** – To start a remote connection with the server, the configuration commands need to be set by following these steps:

- (\$\$\$); type 3 dollar signs to see message with CMD.
- Scan; scan available wireless network.
- Set wlan ssid chortle; ask to join the network.

## The Design of the System Architectures

- Set ip proto; turn HTTP mode=0x10 and TCP mode=0x02.
- Set ip host 10.0.0.11; web server DSN
- Set ip remote 80; set web server port.
- Set sys autoconn 1; automatically connect.
- Set com remote GET\$/work2/allensors.php? Sample server application.
- Set uart mode 2; automatically trigger mode.
- Save and reboot; save configuration and restart (Ghabar & Lu, 2015).

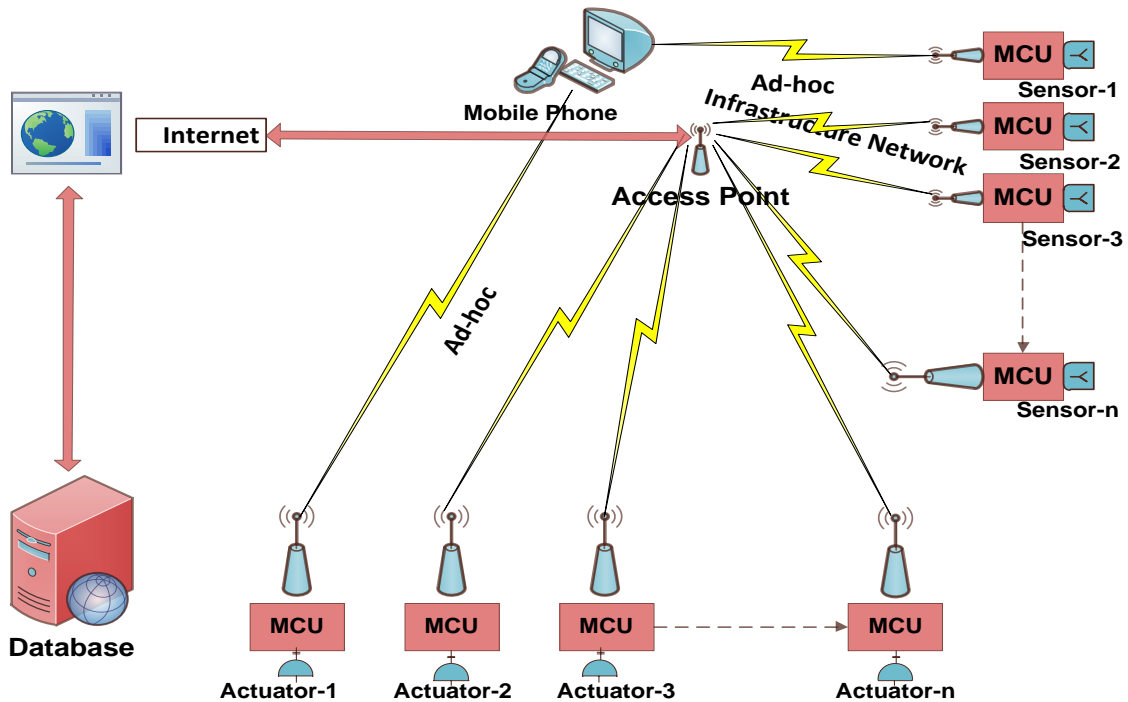

Figure 3-17 Wireless communications over ad-hoc and infrastructure networks

### 3.6.6 Context data processing layer

The context data processing layer is responsible for efficient access to and sharing of information. This is an intermediate layer which is used to make connections between the service layer and physical layer. In this layer there are two modules, which consist of integrating context and updating context.

- 1) Context unification: this unit collects the context information and generates the information for context service adaptation. Several models of pre-processing may be used, for example, event notification or lightweight filtering. This service is the

## The Design of the System Architectures

method by which the model acquires information from the sensors in the physical layer; it is also responsible for a high level of context information acquisition for the application.

- 2) Context updating: this module updates the information in real time, once the data from the context shows a range of variation. With a view to ensuring real-time performance of the system, the strategy of frequently updating the signal layer and the computational load is important.

### 3.6.7 Modelling and processing context-aware data

The environmental awareness produces a large number of sensory inputs that arise from the home environment. These motivations are captured first by an extremely simple sensory system, coded by intelligence, then stored for later use and / or ultimately lost (Hoareau & Satoh, 2009). This process allows user to perceive and adjust our capacity to act in the environment. In most cases, users of smart home applications can either request or not request computing tasks which involve many aspects, and which have been incorporated into the model to cover different areas of the context and different purposes. In order to evaluate a prototype system, scenarios making most use of the entire smart home environment are really the best. Such an investigation should be generated and modelled by the demands of users and should consider applications for all areas. From these points, it can be said that the processing of context-aware data should have the following features: (Vazirgiannis) it is easy to add and remove the context data; (Vazirgiannis) it addresses at least some of the customer's specific circumstances; and (3) the prototype forms are very simple to characterise. Furthermore, one of the key activities in the development process for context-aware applications is to define a model for the representation and management of information (Poveda Villalon, Suárez-Figueroa, García-Castro, & Gómez-Pérez, 2010).

This analysis classifies context into the following scenarios:

- 1- Computation context (CC). This context includes appliances, both software and hardware, which are used to demand or perform the context-awareness.
- 2- Safety context (SC). This relates to events involving user safety, for example, obstacle avoidance, human body and smoke detection.

## The Design of the System Architectures

- 3- Environment context (EC). The environment context is the model's knowledge of the ambient environment, such as temperature, brightness and humidity.
- 4- Time context (TC). This contains information on when the context-aware computing data is received.
- 5- Network context (NC). This models information from the wireless adapter connection, which affects communication from mobile devices.
- 6- History context (Carreras et al.). This context denotes existing data in the context repository.

This model shows five context-aware classes of different kinds in the top layer of the system, which provides the raw data from the physical area and user interaction. The main features of the smart home concern the occupant's dealings with the physical environment and the regulation of home electrical devices. The most important related contexts might be TC, SC and EC, as shown in Figure 3-18, for appropriate smart home residents.

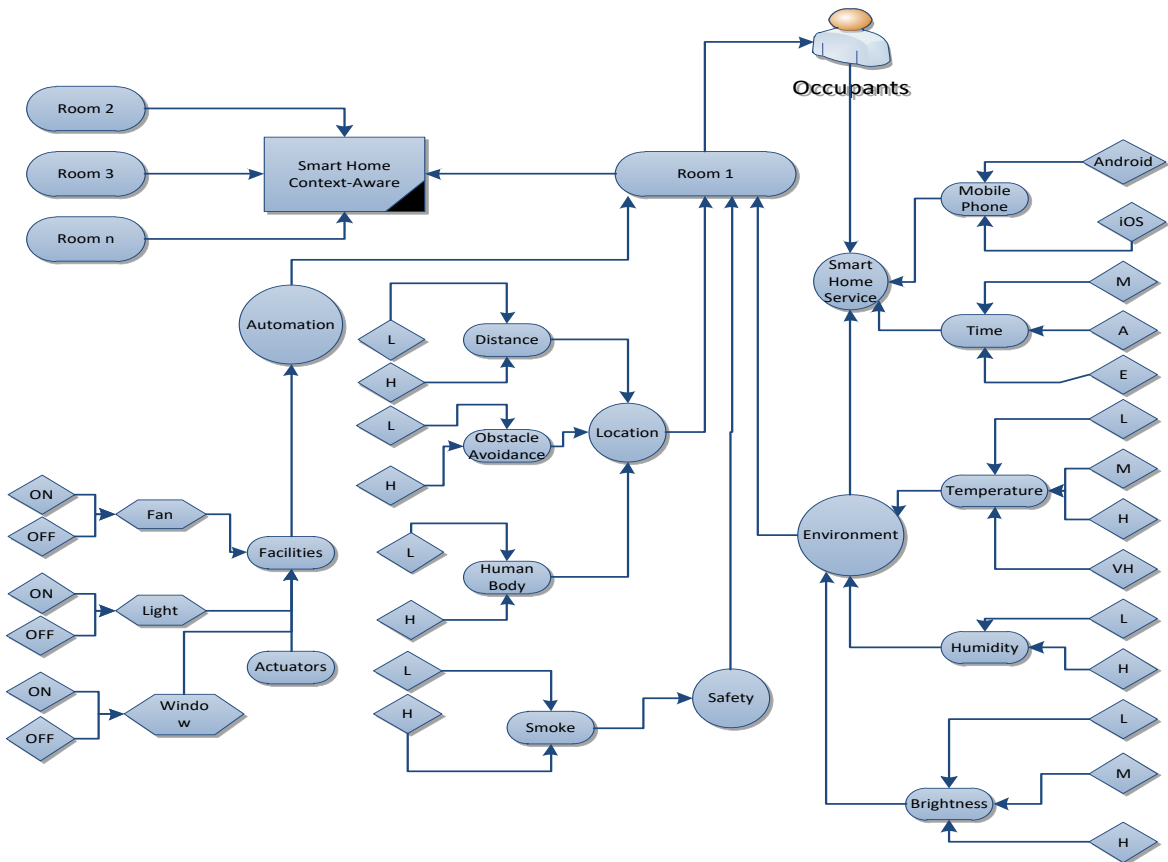

Figure 3-18 Context-aware processing data



## The Design of the System Architectures

### 3.6.8 Database service layer

The main function of the database service layer is to perform a dynamic and computing service. It uses either the service or the context data of the mobile client, and the implicit requirement is to provide services. It reduces the interaction of the user and increases the degree of automation of equipment. In this layer, the first step is case representation, which is related to knowledge reasoning and storage. This is a moveable client application designed to provide user interaction with the computer system. It collects sensor data and instruction from the user and then interacts with the service; it is adapted to the context of the user to provide the information users need. Furthermore, this layer manages the configuration of context-aware information and uses rules to determine current and historical context data.

PHP/MySQL database is a scripting language which is widely used for general purposes. It is particularly suitable for improving a web browser, and can be embedded into HTML by integrating PHP code into HTML documents with specific tags for starting and ending. These features give end users a fast page presentation time as well as great security and clarity. Moreover, being powerful and easy to use, another great benefit of PHP is that it is completely acceptable to the requirements of users. SQL is used for the Database Management System (DBMS), which was created by a Swedish company, and MySQL is a multi-user, multi-threaded system. MySQL has more than 6 million items of data stored (Xu, 2007), so is a large database; in addition, it might be applied in any operating system, such as Windows or UNIX platform. Based on all these advantages, it was decided to implement PHP and MySQL in the current research.

#### 3.6.8.1 Database and its schema

In accordance with the principles identified in section 3-1, it is essential to illustrate the design and structure of the database history which implements attributes for future needs, as shown in Figure 3-19. In order to cover the fundamental tasks of retrieving raw sensor data and developing improvement techniques for the achievement of ideal outcomes, the goals of the database history design must be to save sensor information, integrate data accuracy and provide access to the context data in a convenient way. Designing an efficient context-aware database history is a matter of determining an appropriate process that includes

## The Design of the System Architectures

analysing context sensor data, organising the context-aware information into a suitable table and determining relationships between attributes of the context-aware computing service.

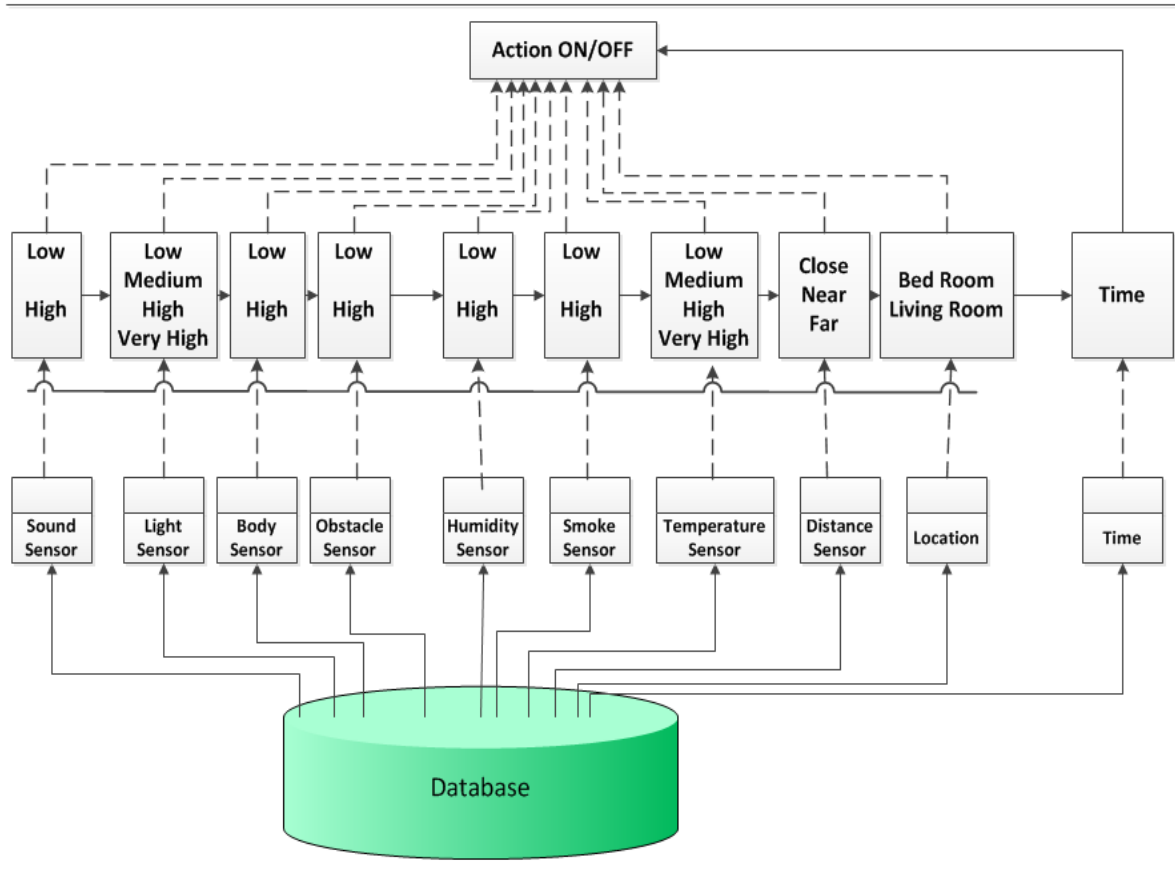

Figure 3-19 Database structure and schema design

This database, which can be considered the framework for the raw sensor data that will be involved in future determination of context items, will become part of the prototype system architecture. Moreover, in order to avoid engaging the same context sensor data in different places on one table, and to make the data less complex, each row within the context-aware database history includes a record of different types of sensor technologies, while the columns contain the fields of sensor attributes, as shown in Table 3-3.

Meanwhile, the construction of relationships, updating of context, queries and viewing of data can be managed by the MySQL database system as shown below.

```
DBService {function tcpUpdate ($v1, $v2, $v3, $v4, $v5, $v6, $v7, $v8, $v9, $tnow) {
    $con = mysql_connect("localhost", "root", "");
```

## The Design of the System Architectures

```

if (! $con)
{
die ('Could not connect: ' . mysql_error ());
}
mysql_select_db ("bigdata", $con);
$result = mysql_query ("INSERT INTO sensordata (sound,
brightness, human, obstacle, humidity, smoke, temperature, distance, device, timenow)
VALUES ('$v1','$v2','$v3','$v4','$v5','$v6','$v7','$v8','$v9','$tnow')");
return $result;
}

function httpUpdate ($v1, $v2, $v3, $v4, $v5, $v6, $v7, $v8, $tnow) {
$con = mysql_connect("localhost","root","");
if (! $con)
{
Die ('Could not connect: ' . mysql_error ());
}
mysql_select_db ("bigdata", $con);
$result = mysql_query ("INSERT INTO sensordata (sound, brightness, body, obstacle,
humidity, smoke, temperature, distance, location, device, timenow) VALUES ('$v1', '$v2',
'$v3', '$v4', '$v5', '$v6', '$v7', '$v8', http://localhost/phpmyadmin'$tnow')");

```

Table 3-3 Database history

	id	Sud	Brn	Bdy	Ost	Hmt	Smk	Tmp	Dst	location	datetime	device
<input type="checkbox"/>	9734	Lu	LI	Hb	Ho	Hh	Ls	Ht	Cd	LR	2015-12-04 16:49:05	FO
<input type="checkbox"/>	9735	Lu	LI	Hb	Ho	Hh	Ls	Ht	Cd	LR	2015-12-04 16:49:11	FO
<input type="checkbox"/>	9736	Lu	HI	Lb	Lo	Hh	Ls	Ht	Fd	BR	2015-12-04 16:49:16	WF
<input type="checkbox"/>	9737	Lu	HI	Lb	Lo	Hh	Ls	Mt	Fd	BR	2015-12-04 16:49:22	FF
<input type="checkbox"/>	9738	Lu	LI	Hb	Ho	Hh	Ls	Ht	Cd	LR	2015-12-04 16:49:36	WO
<input type="checkbox"/>	9739	Lu	MI	Lb	Lo	Hh	Ls	Mt	Fd	BR	2015-12-04 16:49:39	FF
<input type="checkbox"/>	9740	Lu	LI	Hb	Ho	Hh	Ls	Ht	Cd	LR	2015-12-04 16:49:45	WO
<input type="checkbox"/>	9741	Lu	LI	Hb	Ho	Hh	Ls	Ht	Cd	LR	2015-12-04 16:49:50	WO
<input type="checkbox"/>	9742	Lu	HI	Lb	Lo	Hh	Ls	Mt	Fd	BR	2015-12-04 16:49:56	FF
<input type="checkbox"/>	9743	Lu	LI	Hb	Ho	Hh	Ls	Ht	Cd	LR	2015-12-04 17:35:50	WO
<input type="checkbox"/>	9744	Lu	MI	Lb	Lo	Hh	Ls	Mt	Fd	BR	2015-12-04 17:35:56	FF
<input type="checkbox"/>	9745	Lu	LI	Hb	Ho	Hh	Ls	Ht	Cd	LR	2015-12-04 17:36:01	WO
<input type="checkbox"/>	9746	Lu	MI	Lb	Lo	Hh	Ls	Mt	Nd	BR	2015-12-04 17:36:07	FF
<input type="checkbox"/>	9747	Lu	LI	Hb	Ho	Hh	Ls	Ht	Cd	LR	2015-12-04 17:36:12	WO
<input type="checkbox"/>	9748	Lu	HI	Hb	Ho	Hh	Ls	Ht	Cd	LR	2015-12-04 17:36:18	FO
<input type="checkbox"/>	9749	Lu	LI	Hb	Ho	Hh	Ls	Ht	Cd	LR	2015-12-04 17:36:24	WO
<input type="checkbox"/>	9750	Lu	MI	Lb	Lo	Hh	Ls	Ht	Fd	BR	2015-12-04 17:36:30	WF
<input type="checkbox"/>	9751	Lu	LI	Lb	Ho	Hh	Ls	Ht	Cd	LR	2015-12-04 17:36:35	WO
<input type="checkbox"/>	9752	Lu	MI	Hb	Ho	Hh	Ls	Ht	Cd	LR	2015-12-04 17:36:41	WF
<input type="checkbox"/>	9753	Lu	LI	Hb	Ho	Hh	Ls	Ht	Cd	LR	2015-12-04 17:36:46	WO

### 3.6.9 Context-aware modelling

The implementation of the context model may offer suitable computation for context data and automation applications. This model is able to process the application of awareness of resources, smartphone services, and customer interface adaptation to requests. It uses sensors to collect updated data on the environment and then uses the context database to provide contextual services based on standard model operating contexts. A context data model based on the principles of logical organisation used for matching model functions is shown in Figure 3-20.

A high-level data module, in the form of a physical, variable word calculation system within the context-distributed processing model, can support interactions. It is clear that the effectiveness of the context model and the impact of updating the service context will affect reasoning with regard to adaptation. The relationship between the levels of context modelling should be based on a thorough analysis of data attributes, context and allocation of flexibility. In this section, the proposed modelling method needs to be integrated with the context data in order to allow effective interaction with the model.

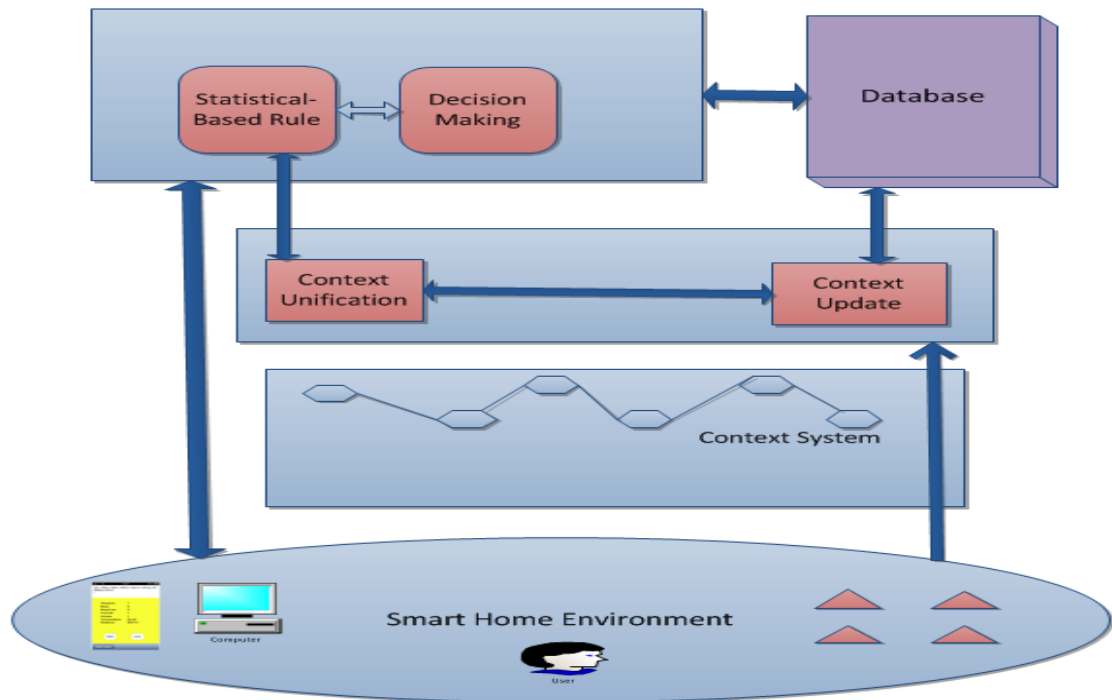

Figure 3-20 Context-aware model

## The Design of the System Architectures

### 3.6.10 Statistical and decision-making layer

The statistical-based rule and decision-making layers are calculated by high-level modules. They use intelligent decision techniques to extract new rules or amend the service to adapt to the dynamic parameters of present rules. These functions are used automatically to manage the reworking of the service. The smart home intelligence network is a Naive Bayesian Decision System (NBDS), which uses smart home sensors designed to detect serious situations when there is likelihood of an event taking place. In addition, NBDS can be used to elicit an interaction between the environment and the home equipment. For example, a better automatic action in response to the data received from the environment in the smart home can be achieved by machine learning based on when the devices are correctly switched on or off by the occupants (Ghabar & Lu, 2014). An example would be regulating the light and fan levels in a room. Such prior probability can be acquired by experience of the real world, which reflects how likely certain events are. In order to achieve this, the Naive Bayes decision method identifies that the probability of the state can be determined by the likelihood of the sensing input data, which gives the hypothesised action to be computed as:  $p(\text{sensing input data} | \text{action})$  (Wolpert & Ghahramani, 2005).

### 3.6.11 Interaction of Machine Learning Uses

The relationships between two interaction devices using machine learning are set up depending on the classification of data. The raw sensor data from smart home environment determines the switch ON/OFF function of actuators. The approach of pre-processing raw sensing data could be utilised to trigger action devices. This pre-processed sensing data should be used to generate decision-making about the conditions within the house facilities. This decision-making is then utilised to find out the appropriate commands which then instruct dynamic action by actuators. Moreover, optimising of decision-making using two different concepts of decision-making and appliances control is achieved by using a clear loop construction between low-level and high-level system architecture.

### 3.6.12 SHS Context-aware Automation and Decision Support

The scenario within this case study investigation employed a smartphone (iPhone device) and some sensor technologies alongside an embedded system for home facilities remote

## The Design of the System Architectures

control managed by context-aware computing service methods. The aim is to provide affordable and appropriate computing services which are computing to the context-aware environment for each client. There are different types of separate sensor utilised to recognise the resident's ambient context. The MCU embedded system is used to connect with the actuators, the Wi-Fly adapter and sensors to the personal computer. The main objectives which are to be realised in this system implementation are: (Vazirgiannis) to determine the effectiveness and time consumption of the system implementation using context-aware model, theories and methods, (Vazirgiannis) to evaluate the statistical-based rule based on context-aware computer service for physical service provisioning, (3) to improve the usefulness of the smart phone devices and sensor technologies for remote control assistance in the smart home facilities. To pursue these objectives and effectively evaluate the recommended approaches, the system implementation, outcomes and assessment are described in this section.

The most important tasks in order to achieve the construction of the system design and implementation for (WiSAMCinSH) are:

- 1- Collecting context raw information through heterogeneous sensors technologies.
- 2- Context-aware reasoning.
- 3- Context-aware automated service.
- 4- Statistical-based rule using database history.

The history of database context of the smart home situation is stored in the context repository for statistical-based rule service. The search engine EF-ICF-IF and supervised machine learning (Naive Bayesian decision) methods are implemented in this scenario. The maximum a probability (MAP) rule can be used with decision-making logic rule to reconsider the computing service and choose the outcome which has the maximum probability based on the database.

### **3.7 Summary**

This chapter has provided an in-depth introduction to the design and implementation of the prototype system, and described the structures through an investigation of the model. This

## The Design of the System Architectures

model consists of a lightweight configuration of the features identified, which are based on the system named Wireless Sensor Actuator Mobile Computing in the Smart Home (WiSAMCinSH) (Ghabar & Lu, 2014). This system can be employed to gather information from different sensors and techniques. Here, a smartphone with wireless communication, adapter and associated embedded system technologies have been presented. Then, in the next section, the five layers of a general architecture model for dealing with context-aware information from various context sources have been explained. It is convenient to consider such a model and then plug in various features and computing methods to develop and enhance it. In the model design considered, the data comprise raw information, computed values and context-aware estimations, and the database is applied using the Apache service. Next, Chapter 4 will explain the experimental setup and the results of the context data from various sensors, as well as the mobile applications interface for both monitoring and controlling home facilities.

## **Chapter 4 Experimental Configuration and Results**

### **4.1 Introduction**

The service's database history has been applied using Apache/MySQL/PHP on both iMAC and Intel(R) machines. The platform can transfer data to another associated context, which provides the necessary data for decision-making. Each event is sent to all relevant identification platforms of the information server, and it is possible to use the algorithm and database for classifying the complex and sophisticated patterns which apply to most data. The data history suggests that it is necessary to utilise Naive Bayesian decision making in smart home automation to predict actions.

The prototype system was applied to an example scenario involving elderly people, using smart home automation to control the home facilities. This involved the use of four electrical devices, two fans and two LED lights, which needed to be switched ON or OFF depending on the home environment's temperature and brightness. The four action (class) problems identified before running the model were light ON (LO), light OFF (LF), fan ON (FO) and fan OFF (FF). The algorithm used in this experiment was the Naive Bayesian classifier tool. This model could be run by different services, such as local host Visual Studio/C Sharp 2013 (ASP.NET) or Remote Apache/MySQL/PHP, with the codes being decided by the researcher or another editor. The database history was learnt by utilising a learning model provided in the WEKA tool.

### **4.2 Experimental data collection and process**

The experiment was carried out in the laboratory at Huddersfield University 'live-in laboratory' over a period of five months between April 1<sup>st</sup> and August 30<sup>th</sup> 2015, which would allow an evaluation of the time complexity for smart home facilities. The number of context samples gathered from eight sensors comprised 330 sample rows. These data were transferred via wireless adapter, then saved in the database history for analysis using PHP MySQL and for the next stage of service decision making.

Due to the complexity of the physical situation in the intelligent building, practical evaluation of this model was accompanied by many difficulties, particularly as the system



## Experimental Configuration and Results

involved different kinds of technologies and methods. Therefore, the number of participants was just one person, and the context-aware computing service was executed using methods of probability-based rule control, which is not commonly utilised in this area of research.

In addition, the prototype system was built to work with a smartphone, such as an iPhone, to acquire data from the wireless sensors and display the data on the screen. A wireless temperature sensor was used, along with other classes of sensors, to develop and progress the smart home functions with the goal of offering services suitable for elderly people. The software program designed for this work was divided in two parts, one for home monitoring and the other showing the remote control of home devices.

It was important for the context-aware model that an appropriate number of context-aware samples was collected to efficiently generate effective methods, and then to incorporate the created functions into the search engine and Naive Bayes decision making. The main functions involved in the communication system were, for instance, context information acquisition, updates, requests, resident remote control using smartphone, and context service execution. These functions were performed by the following methods:

*From sensor to embedded system* – This communication was realised through low-layer physical logic, for example one-wire Bus, I2C, and GPIO.

*From embedded system converter to Wi-Fly adapter* – The connection between embedded system and Wi-Fly was an RS-232 serial port.

*From Wi-Fly adapter to remote control server* – This configuration was via HTTP requests (POST, GET, PUT, DELETE); example requests would be:

For context update: *POST* function `httpUpdate ($v1, $v2, $v3, $v4, $v5, $v6, $v7, $v8, $tnow) {$con = mysql_connect("localhost", "root", "");`

*GET* function – Set com remote `GET$/work2/allsensors.php?` Sample server application

*From smart phone to Wi-Fly remote control server* – For this, the HTTP requests POST, GET, PUT and DELETE were used as well.

This involved the prototype design for a sensor system as shown in Figure 4-1 and Figure 4-2, and the implementation of relays to control the smart home devices. The laboratory was equipped with eight sensors interfaced with the MCU (STC89C52RC), and Wi-Fly (RN370)

## Experimental Configuration and Results

was adopted with a PC and smartphone using an ad-hoc wireless network connection. The same configuration was used for the actuators as in other embedded systems, and a Wi-Fly adapter for smart home automation functions was applied. In the experiment involving the actuators, four electronic devices were connected to the embedded system: two LED lights and two fans. For the design and implementation of the appliances to control the smart home electrical devices, further steps were needed in order to perfect the model. While the microcontroller unit was the main device in the system design, certain other devices needed to be connected in order to achieve the task. Each relay required three pins to be integrated with the MCU: the VCC for power supply (5V); GND for ground (0V); and another for the input signal. On the other side, two ports needed to be connected with the electrical devices: one connected to the VCC and the other to ground.

The aim of this section is to demonstrate the building of the system design for Wireless Sensor Actuator Mobile Computing in the Smart Home (WiSAMCinSH), as well as to present and discuss the experimental results. The prototype system was established with an obstacle avoidance sensor to test the MCU (STC89C52RC) and to ensure that the software and hardware were working well; after that, various sensors were connected to the MCU to test for human body presence, temperature, brightness, smoke and humidity.

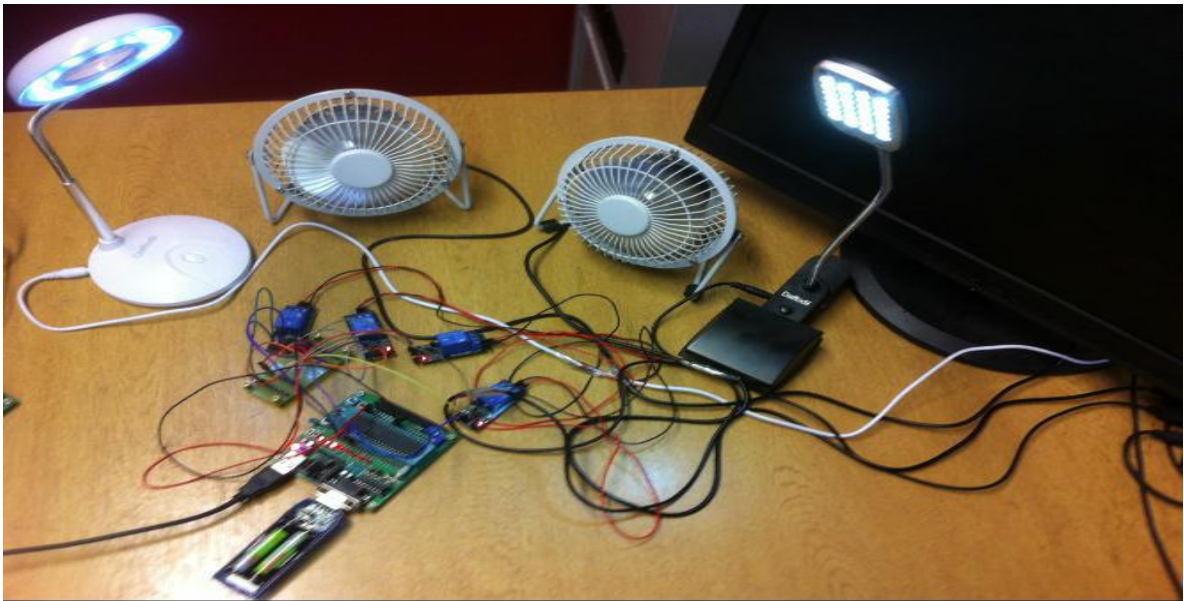

Figure 4-1 The MCU, Wi-Fly RN-370 and four relays connected with LED lights and fans

## Experimental Configuration and Results

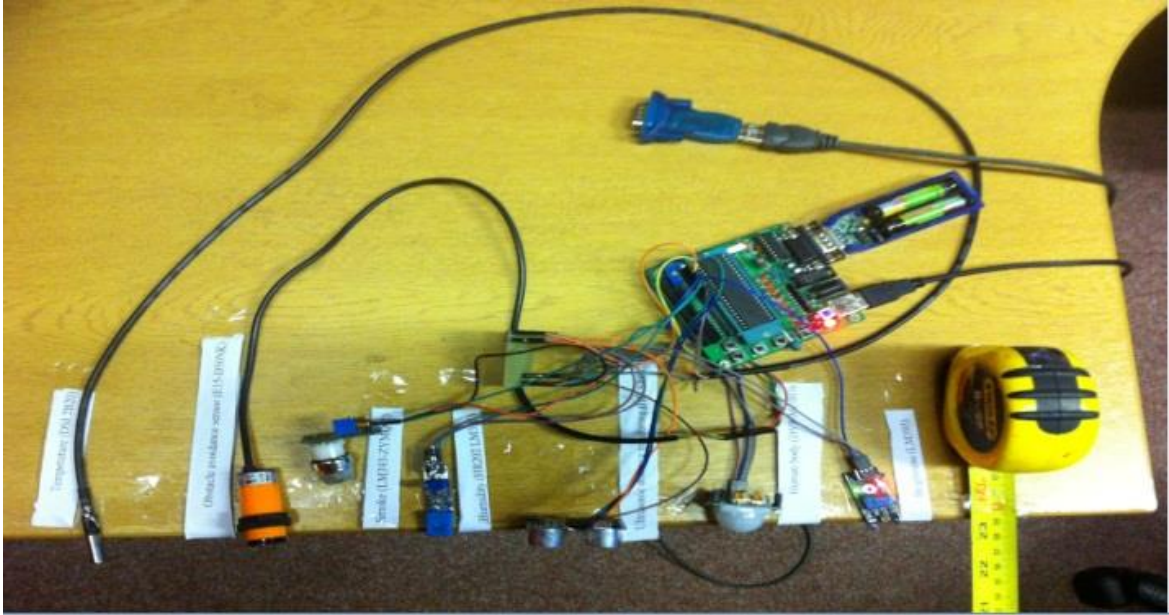

Figure 4-2 The MCU, Wi-Fly RN-370 and eight sensors connection

The main model system was broken down into two main parts, hardware and software, that were available in the laboratory.

➤ Hardware:

- PC working with Windows 7
- Eight kinds of sensors
- Actuators
- MCU (STC89C52RC)
- Wireless adapter (Wi-Fly-RN370)
- iPhone 4 (Version iOS 6.1.3)
- IMac version 10.7.5.

➤ Software:

- C language for MCU
- Objective-C for iPhone application
- Apache/MySQL/PHP (XAMPP 1.8.1) service
- Tera Term program
- Visual Studio/ C Sharp 2013 (ASP.NET) framework service

## Experimental Configuration and Results

The prototype system for the experiment is shown in Figure 4-3, which illustrates how the laboratory was prepared with eight sensors and interfaced with the MCU (STC89C52RC) and Wi-Fly (RN370), configured with a PC using both wired and wireless connections.



Figure 4-3 Experiment platforms in the laboratory

Besides the Wi-Fly serial adapter, the PC was installed with the software program Tera Term version VT100 for wireless data collection, which is free for Windows 7, as well as a wired serial port tester (RS232).

### 4.2.1 Setup and configuration the system by user

Since the proposed prototype system consists of two major mobile phone applications using an iPhone 5s in the ambient smart home environment, the mobile phone serves as the main interface between the elderly people and the computer system. Therefore, the developer should be expected to set up both the hardware and software requirements. Generally, the system configuration for the elderly people could be expected to be as follows:

The sections 4.2.2 and 4.2.3, which can be seen in the following pages, provide an in-depth explanation of how the developer can initiate the setup and configuration of the smart home system by means of three different methods. The setup and configuration of the mobile phone application is expected to be provided for the elderly persons for physical remote control, monitoring the home environment, and preference setting. The interface can utilise

## Experimental Configuration and Results

a UDP/IP, or connect directly with the Wi-Fly adapter or access point automatically. The software allows the elderly people themselves to configure the connection to both applications monitoring and remote control of the home environment and facilities.

Figure 4-14, which can be seen below, illustrates three screenshots of the smart home application: setting up the connection, configuring the monitoring screen to display the context data, and finally, remotely controlling the home devices. The first screenshot shows the setup application, which is establishing the connection between the mobile phone and the communication adapter. For the elderly citizen to operate the application, it is just necessary to press a 'SET' button. After that, the elderly person will receive a message 'Please Setup Your Ad-hoc First', then should press the 'SET' button to receive a message 'Connection successful'. The next step is that the person should press a 'Login' button to switch the view to that shown in the second screenshot. This displays the context information from the embedded sensors which collect it, using HTTP protocol with a 'split' function to change the data display from rows to columns in order to be appropriate for elderly users.

The last step is to switch the view to show the status of the appliances and the remote control application. This interface is the main function in allowing the elderly people to control the home facilities. This screenshot shows that preference setting is permitted, according to the context gathering data, in order to execute whichever device is appropriate. When the elderly residents are close to the sensing area, their daily life activities can be easily realised in real time on the front of the system. This involves sensors such as the obstacle avoidance sensor, human body sensor and ultrasonic sensor to measure distance. At the same time, the model can store the sensing information in the database history and analyse the situation of the home environment, using both search engine and machine learning tools. The main advantages of this system are that the setup of the smartphone application interface for home monitoring and home facilities control can be easily configured by the elderly people themselves. There are three techniques for setting up the configuration of software, as follows.

## Experimental Configuration and Results

### 4.2.2 Setup configuration through serial port tester RS232:

This technique requires a serial port terminal program to be installed, which has to interface between the MCU (STC89C52RC) and the PC to gather information from the sensors connected to the MCU. Next, the serial port tester program is opened and 'port' is selected, then 'settings', to set up the value of RS232 as COM5, baud rate 9600, data bits as 8 bit and non-parity, which is interfaced with the PC (Wi-Fly, 2012), as shown in Figure 4-4.

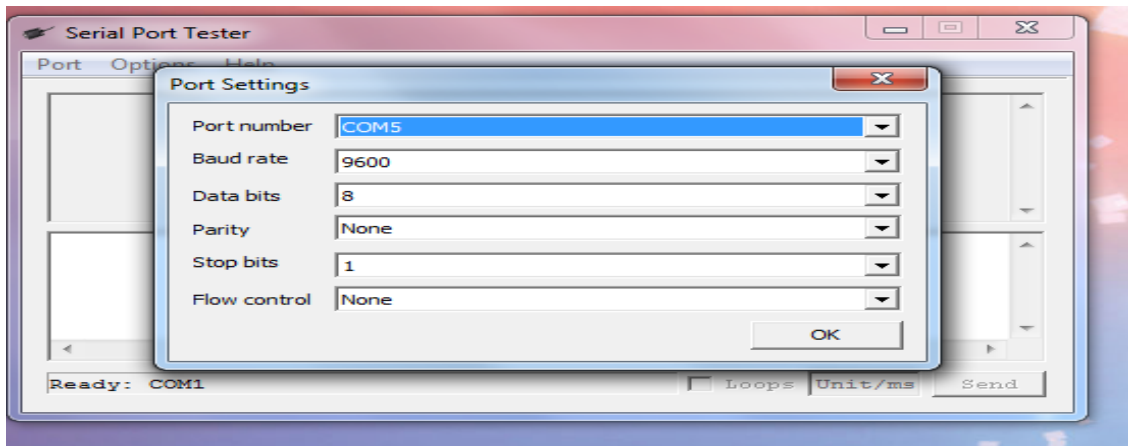

Figure 4-4 shows how to set up serial port tester RS232

When the configuration has been set up successfully, it gathers input data from the different sensors connected to the prototype system.

### 4.2.3 Setup configuration through Wi-Fly serial adapter using Tera Term:

This configuration is used through Ad-Hoc mode (point-to-point), with switch 1 ON. The ad-hoc mode powers up the Wi-Fly device, which is only connected between two appliances, enabling the smartphone (iPhone) or PC to gather data or control a device through the serial interface. This Wi-Fly device needs to set the constructor default value as follows: Service Set Identifier SSID, which is Wi-Fly-GSX-a5, to the IP address 169.254.1.1, with IP net mask of 255.255.0.0 and TCP port 2000, as shown in Figure 4-5 (Teranishi, 2007).



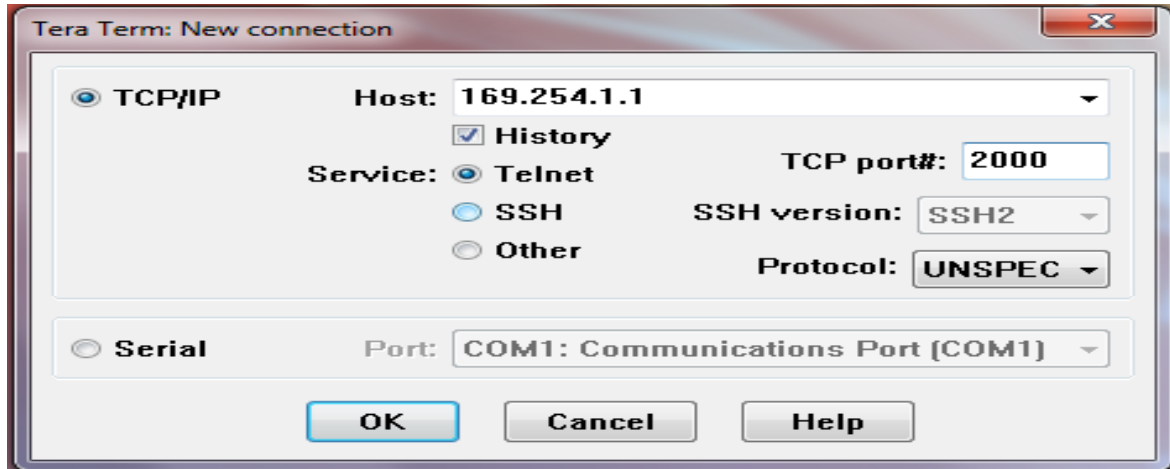

Figure 4-5 Connection setup with Wi-Fly (RC370)

When the connection is made with the ad-hoc mode, it takes only a short time (one-to-two minutes) to pass any IP address to the computer. After this, when ‘OK’ is pressed, ‘Hello’ will appear on the Tera Term program. Then, the sensors will pass information derived via the MCU and Wi-Fly to the user. Tera Term will also show data on the user’s context and situation to the sensors (Ghabar & Lu, 2014).

#### 4.2.4 Setup configuration through Wi-Fly RN370 using iPhone:

There is no necessity for a central location to set up a connection between Wi-Fly and phone using an ad-hoc mode interface. Information can travel immediately to the wireless appliance using point-to-point connection. As the first step, the power supply and ad-hoc switch are turned ON for the Wi-Fly to operate (Ghabar & Lu, 2014). This establishes the default value provided by the manufacturer (see Table 4-1). The second step is to link the wireless system and an iPhone by means of the Wi-Fly. The wireless network can be created by a smartphone using DHCP (Dynamic Host Configuration Protocol).

The smartphone produces ad-hoc mode by means of an SSID (Service Set Identifier) and its concomitant Wi-Fly-GSX-a5 network. The service and user (client) have the IP address 169.254.1.1 (Ghabar & Lu, 2014) See Figures 4-6a and 4-6b to view the set-up plan of the Wi-Fly network.

## Experimental Configuration and Results

Table 4-1 Shows the default value between iPhone and Wi-Fly (RN370)

SSID	WiFly-GSX-a5
Channel	ONE
DHCP	ON
IP address	169.254.1.1
Netmask	255.255.0.0
Port	2000

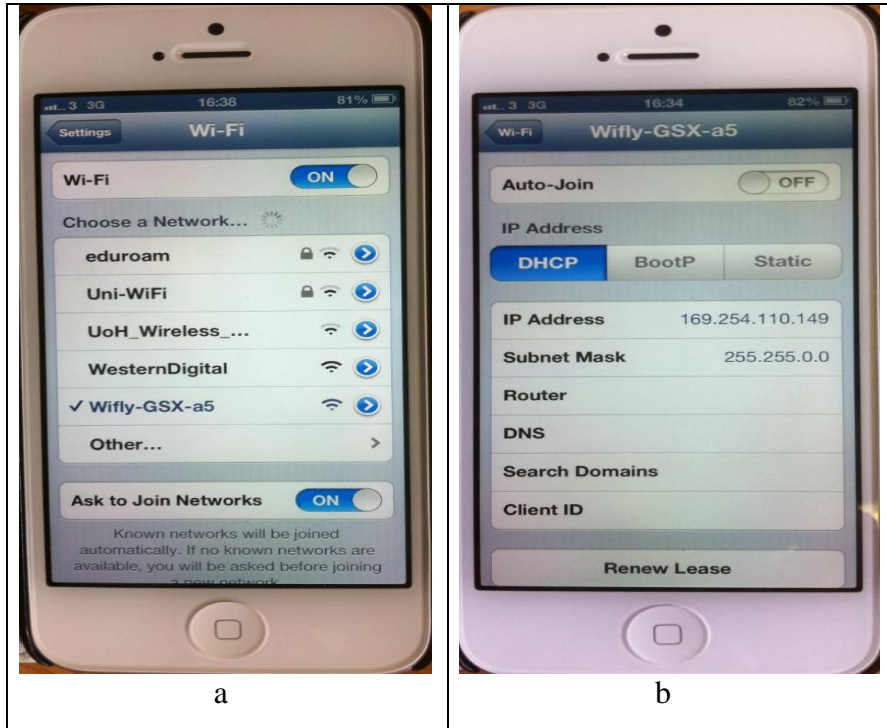

Figure 4-6 shows the setup of an iPhone with Wi-Fly-GSX-a5

### 4.3 Compiler programmer in Keil uVision3

In this section, the results of experiments with six different sensors using three separate methods of testing in the laboratory will be shown, as stored temporarily in the STC89C52RC MCU. Next, the software program and compiler go through the 'debugger' (Keil uVision) test program for the debugging instruction (see Figure 4-7). The program runs concurrently in STC-ISP.exe when the hex file and PC port have been chosen and made ready to send the data by wired or wireless methods (Ghabar, 2014). As the final step, the



## Experimental Configuration and Results

data are retrieved from the memory and the output information is displayed by either the serial port tester screen, the iPhone screen or the Tera Term screen (Ghabar & Lu, 2014).

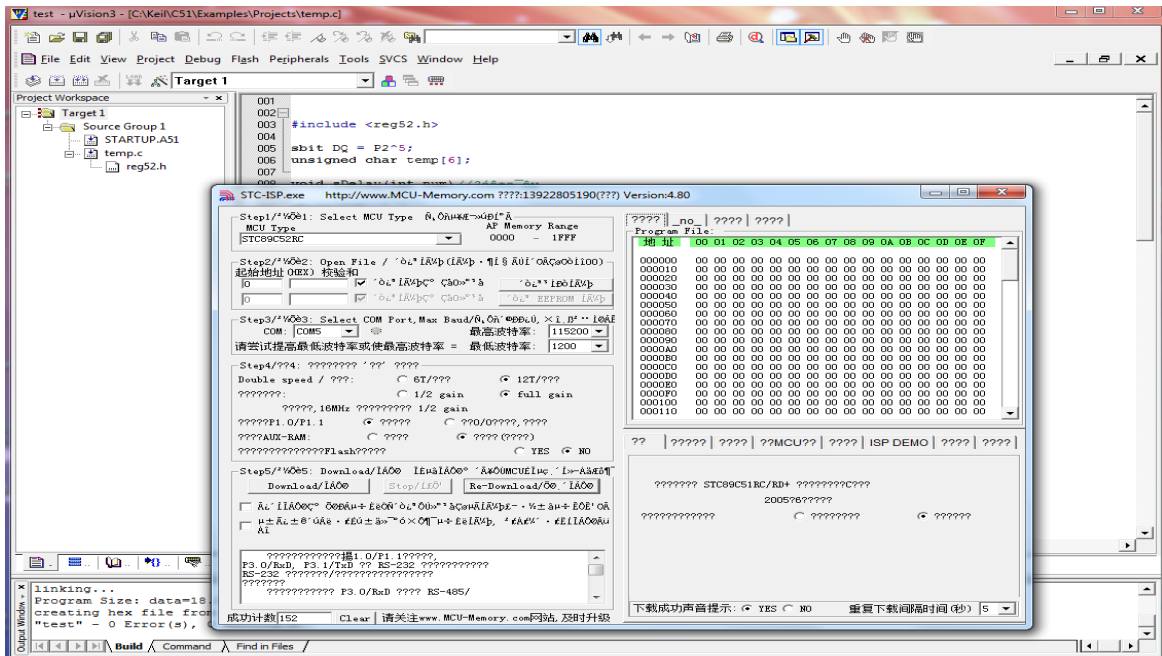

Figure 4-7 shows the software Keil uVision3 and STC-ISP.exe

This step is designed to monitor the environment and security of the smart home occupants by monitoring the output value for each sensor according to its function. For example, the information received from the temperature sensor in the serial port changes in relation to the room temperature. The prototype system was constructed to work with a smart phone so that information collected from the wireless sensors could be shown on its screen. Various types of sensors, including a wireless temperature sensor, were tested in this research, in order to further develop the smart home function with the ultimate aim of providing helpful aids for elderly people, probably living alone. The software program for this work consisted of two parts: one to use the home temperature sensor, and the other to use information from the other sensors.

Many experiments were performed in the laboratory to evaluate the performance of the WisAMCinSH prototype in using other types of sensors, such as obstacle avoidance, human body, brightness, smoke and humidity sensors. This part of the experiment gives different function output results from the sensors by converting real-world physical variables to

## Experimental Configuration and Results

digital variables (0 or 1) that can be processed within the computing system. A trigger mode was used to acquire the physical events information. When a high voltage output appears in the sensing area, the output will change to low (0) after a delay time, but when the sensing range is affected by physical objects, the output voltage will remain high (Vazirgiannis) until the object leaves the sensing area. Some of the results taken from the laboratory experiments are shown in Figure 4-8.

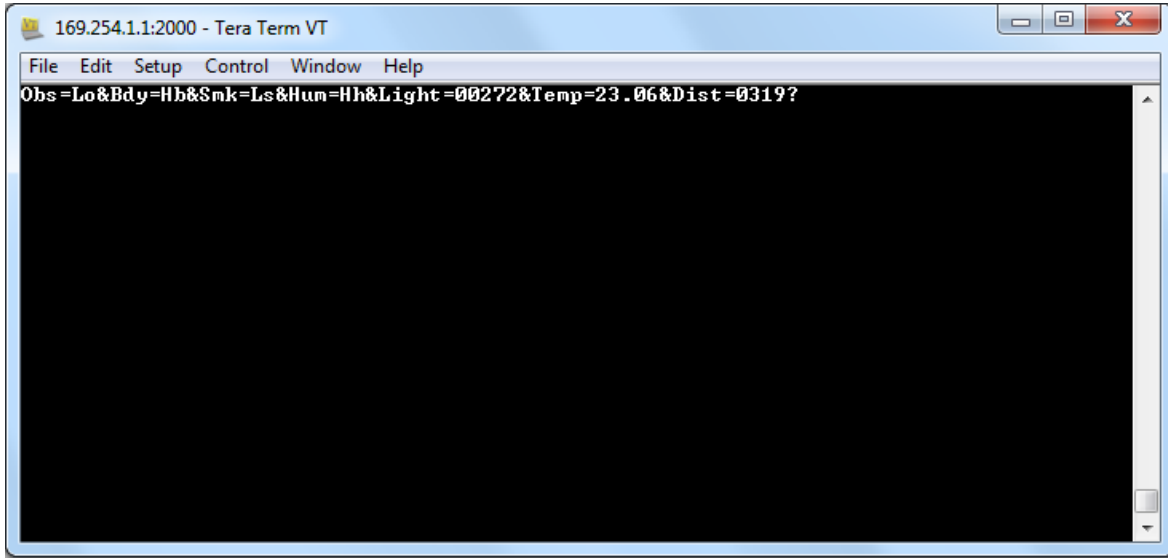

Figure 4-8 Reading of sensor data for wireless methods

These are the last observations taken from the experiment gathering information from sensors using the Wi-Fly serial adapter and iPhone. The sensing data was first collected by the MCU and then sent to the smartphone via the Wi-Fi transceiver. The information was gathered from port P2, with five pins from P2<sup>0</sup> to P2<sup>8</sup>. The port P2 register and the pins should be set to '1' before reading the data, in order to be compatible with the MCU functions.

### 4.4 Sensor Testing Results

The accuracy of the sensors' measurements is distinguished by the performance of each sensor, and the results show how faithful the accuracy can be to the actual value. An efficient sensor would be expected to show a high quality performance. For testing to be successful, it is necessary to make comparisons with the evaluations of other devices, such as the

## Experimental Configuration and Results

TermPro-TP-60 (indoor/outdoor humidity and temperature monitor) and a digital lux meter (FC/LUX), and to use real-world results. A previous study found that data gathered at any particular time on a weekday, for example from 12:00 pm to 5:30 am, could vary according to different resident levels and laboratory environments (Aswani, Master, Taneja, Culler, & Tomlin, 2012). Results of this kind would enable the researcher to understand whether the sensors can work accurately according to their functions. Therefore, some experiments were carried out to evaluate the sensors' results.

### 4.4.1 Results from the temperature sensors

In order to evaluate the results for the temperature sensor, it was important to compare the results of the sensor with those from a thermostat during the daytime from 10:00 am to 8:00 pm. To achieve this, a radiator heater system was switched ON and OFF over a period of three days. This test took into account the temperature and humidity both indoors and outdoors using a wireless thermostat set up inside the laboratory. Figures 4-9, 4-10 and 4-11 show comparisons between the indoor temperature sensor value and the indoor and outdoor temperatures from the thermostat. The latter values were taken between 10:00 am and 8:00 pm, which was the same period as that used for evaluation of the working sensor. Figures 4-9, 4-10 and 4-11 illustrate the three temperature results used in this evaluation, where the blue line represents the indoor temperature sensor with the radiator heater system, the red line shows the thermostat temperature indoors with the radiator heater system, and the green line is the thermostat value for the temperature outdoors during the day without the heater system.

## Experimental Configuration and Results

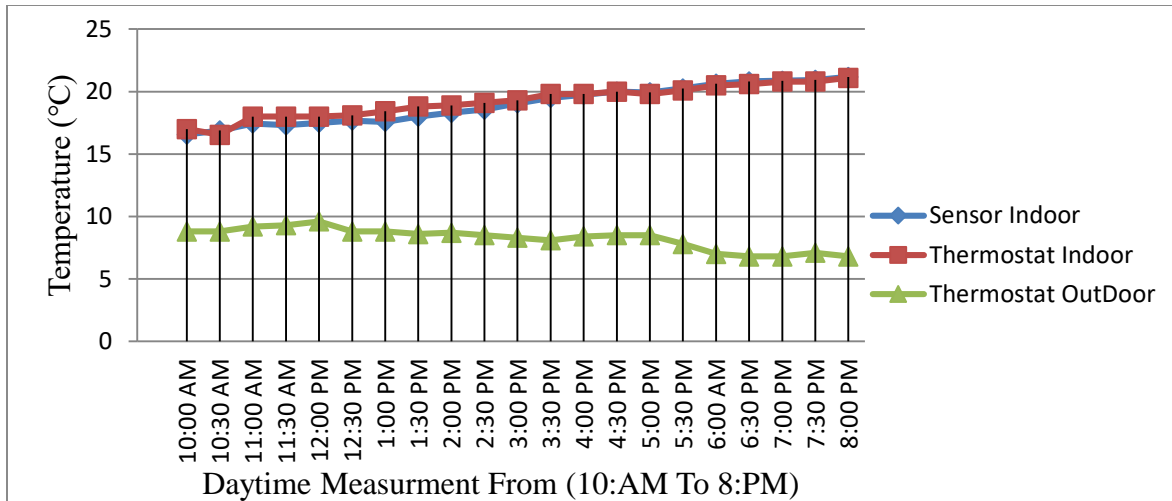

Figure 4-9 First day evaluation of temperature by sensor DS18B20 and TermPro-TP-60

Figure 4-9 shows the results for the first day, when the heater was switched OFF between 10:00 am and 1:00 pm. A temperature ranges between 16.56°C and 17.58°C was recorded using temperature sensor DSI-2B20 and a range between 17°C and 18.42°C was recorded by the thermostat at the same time. After that, when the heater system was switched ON from 1:30 pm to 8:00 pm, the temperature values showed an increase from 18°C to 21.18°C and 18.8°C and 21.1°C for temperature sensor DSI-2B20 and thermostat TP-60 respectively. Meanwhile, the wireless thermostat TP-60 identified an outdoor drop in temperature from 8.8°C to 6.8°C between 10:00 am and 8:00 pm.

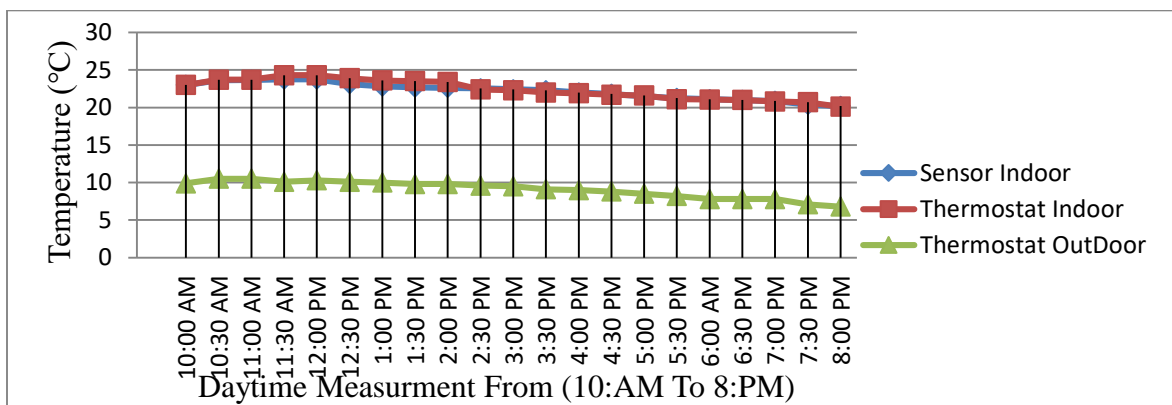

Figure 4-10 Second day evaluation of temperature by sensor DS18B20 and TermPro-TP-60

## Experimental Configuration and Results

Figure 4-10 illustrates the second day's experimental results, when the heater was switched ON between 10:00 am and 12:00 pm. A rise in temperature from 23°C to 23.75°C was identified by temperature sensor DSI-2B20, while the thermostat recorded a temperature rise from 23°C to 24.3°C at the same time, which is approximately the same. Then, when the heater system was switched OFF from 12:30 pm to 8:00 pm, the temperature values showed a drop from 23.12°C to 20.18°C and from 23.9°C to 20.1°C for temperature sensor DSI-2B20 and thermostat TP-60, respectively. The wireless thermostat TP-60 identified a drop in outdoor temperature from 9.9°C to 6.8°C between the morning and afternoon.

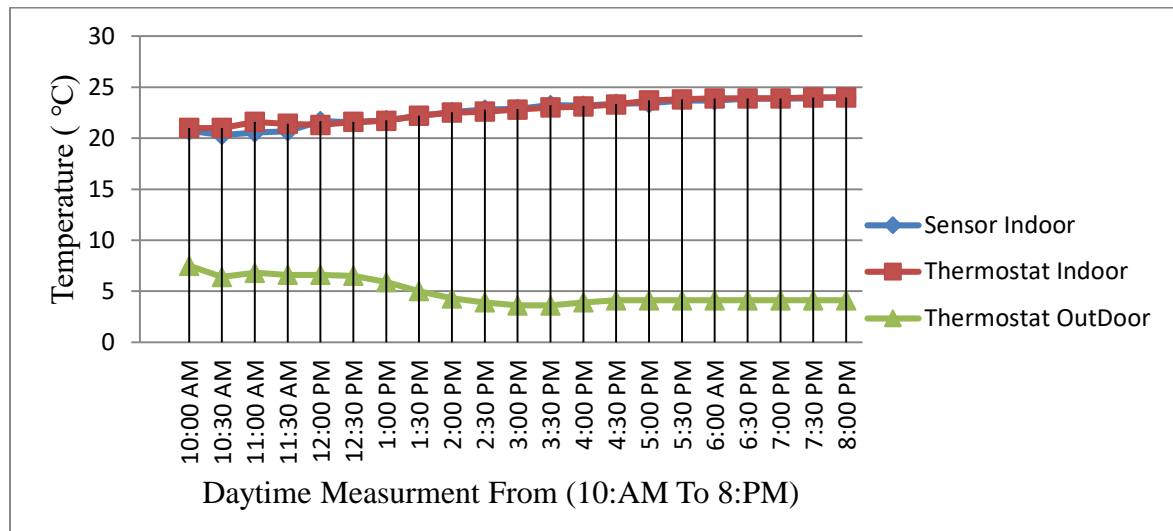

Figure 4-11 Third day evaluation of temperature by sensor DS18B20 and TermPro-TP-60

Figure 4-11 shows how the temperature changed during a third day of experimental measurements when the heater system was switched ON all day between 10:00 am and 8:00 pm. The line chart illustrates that the range of temperature increased from 20.75°C to 24°C using temperature sensor DSI-2B20, while the temperature range recorded by the thermostat was between 21°C and 24°C at the same time, which is approximately the same. Meanwhile, the wireless thermostat TP-60 identified a drop in outdoor temperature from 6.4°C to 4.4°C during the whole day. Generally, all the graphs illustrate that the range of temperature values recorded by both devices show an increase when the radiator heater system was switched ON and a drop when the heater system was switched OFF. Significantly, the results from the temperature sensor and the thermostat device are approximately close to each other, and

## Experimental Configuration and Results

human beings will be little affected by a difference of, for example,  $0.25^{\circ}\text{C}$ . This means that the sensor's functionality has a very high level of accuracy when compared with the TermPro-TP-60 (indoor/outdoor humidity and temperature monitor) results.

### 4.4.2 Results from the ultrasonic distance measurement sensor

Accurate measurement of ultrasonic distance is necessary for the equipment to be successful. Figure 4-12 demonstrates the accuracy of the sensor's measurement results for lengths between 5 cm and 80 cm. At distances greater than 40 cm, errors of up to 0.9 cm showed for each 5 cm distance. After 45 cm, however, the errors increased and reached 5 cm at the 80 cm distance. Obviously, therefore, this sensor would need adjustment to improve its accuracy. The last step was to experiment with the use of an ultrasonic distance sensor to measure the distance between the sensor and the object to be identified. This was intended to discover whether body, smoke and obstacle sensors could be effective over longer distances (Ghabar & Lu, 2014).

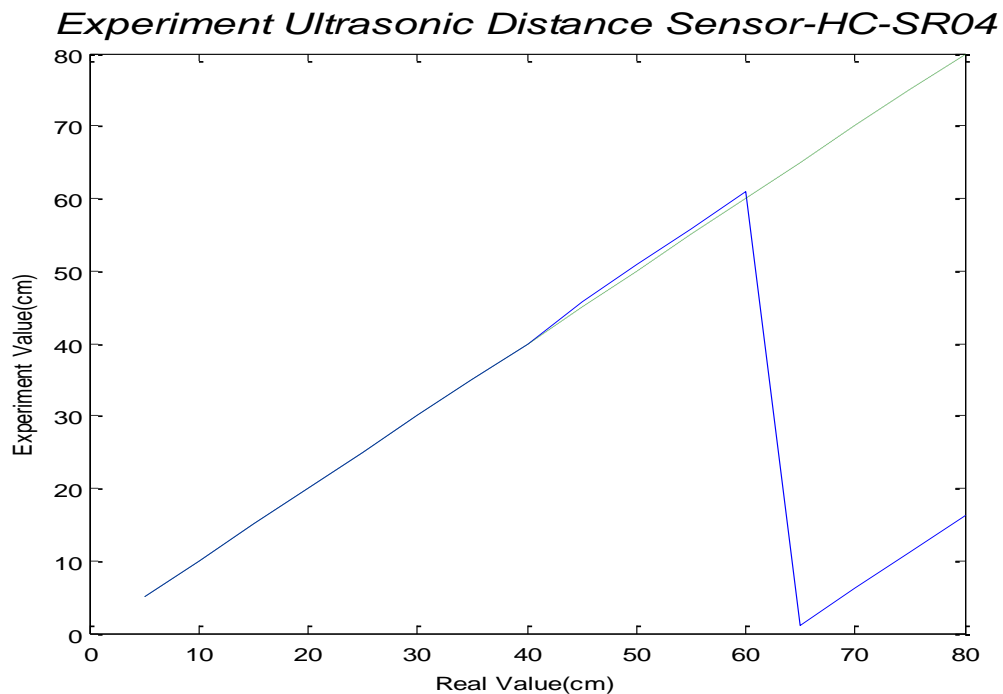

Figure 4-12 shows the ultrasonic measuring sensor; the dashed line is the real measured value

## Experimental Configuration and Results

### 4.4.3 Results from obstacle and body sensors

Figure 4-13 shows a graph comparing the experimental results from three sensors. The sensors were tested at increasing distances from 5 cm up to 80 cm. As the graph shows, the obstacle sensor detected the object at distances between 5 and 40 cm at a high voltage, but dropped to 0 volts at between 45 and 80 cm. The sensor performed better with a human body, detecting it at high voltage from 5 cm right up to 80 cm. There was no opportunity to test the smoke sensor, as there was no suitable occasion to do so (Ghabar & Lu, 2014).

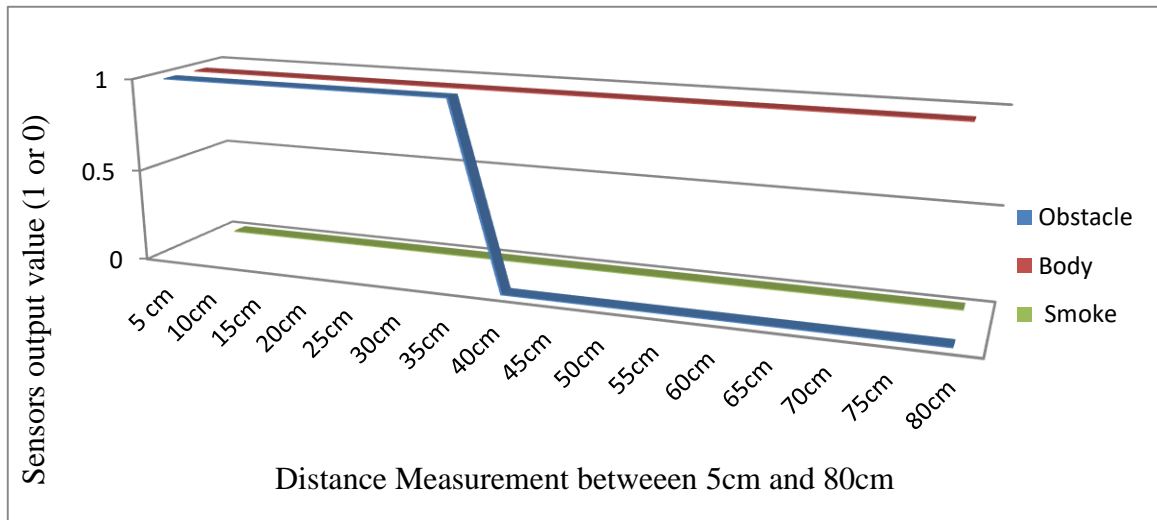

Figure 4-13 illustrates the results of three digital sensors

### 4.4.4 Results from the brightness sensors

To assess the brightness sensors, another comparison was made, this time based on the results of a study by Goswami, Bezboruah, and Sarma (2009), which used light brightness sensors (LDR) to measure light intensity during daytime. To evaluate the intensity of illuminance, the brightness sensor (BH170) in this prototype system was compared with a digital lux meter (FC/LUX). The results were taken between 12:00 am and 11:00 pm, with and without light in the university laboratory, as illustrated in Figures 4-14, 4-15 and 4-16. This was in order to show the performance of the light sensor, which would be used with LED light in the smart home and controlled by a smartphone or machine learning computing service. In order to offer greater performance and better illuminance and brightness intensity control, it was essential for this to be done using a uniform technique across a varied range

## Experimental Configuration and Results

of actual brightness information and light sources. The accuracy of the results illustrates how faithfully the sensor can measure the real-world actual value.

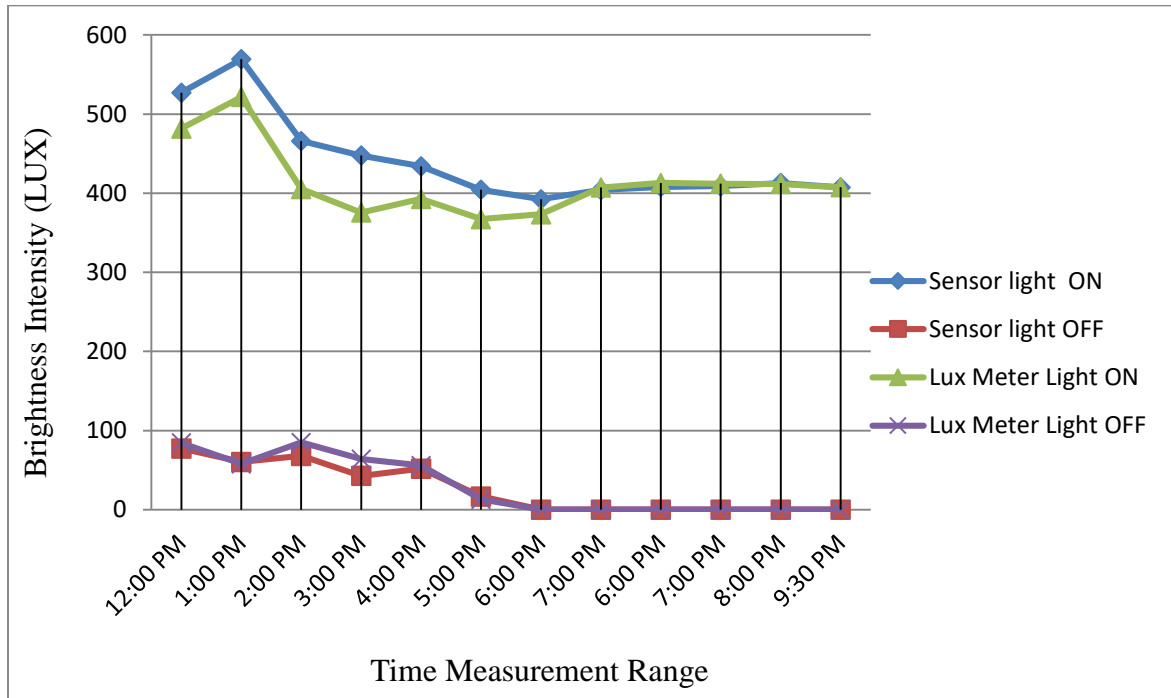

Figure 4-14 Comparison of first day's results for light intensity during daytime, with and without light

Figure 4-14 shows the first day's results from the ambient light sensor (BH170), which is designed to control the brightness intensity in the smart home facilities, compared with those from the digital lux meter. The original experiment mentioned above was performed to investigate the accuracy of light sensors and lux meters in assessing the availability of brightness and illuminance for ideal display visibility and energy efficiency. The current experiment was done when the light was switched ON and OFF for both devices, light sensor and lux meter, between 12:00 am and 11:00 pm. The line chart shows that between 12:00 am and 11:00 pm, the light intensity recorded when the light was ON ranged from 527 lux to 407 lux, and from 481 lux to 407 lux, as recorded by the light sensor and lux meter respectively. When the light was OFF, the recorded range shown between 12:00 am and 11:00 pm ranged from 77 lux to 0 lux and from 84 lux to 0 lux, respectively.



## Experimental Configuration and Results

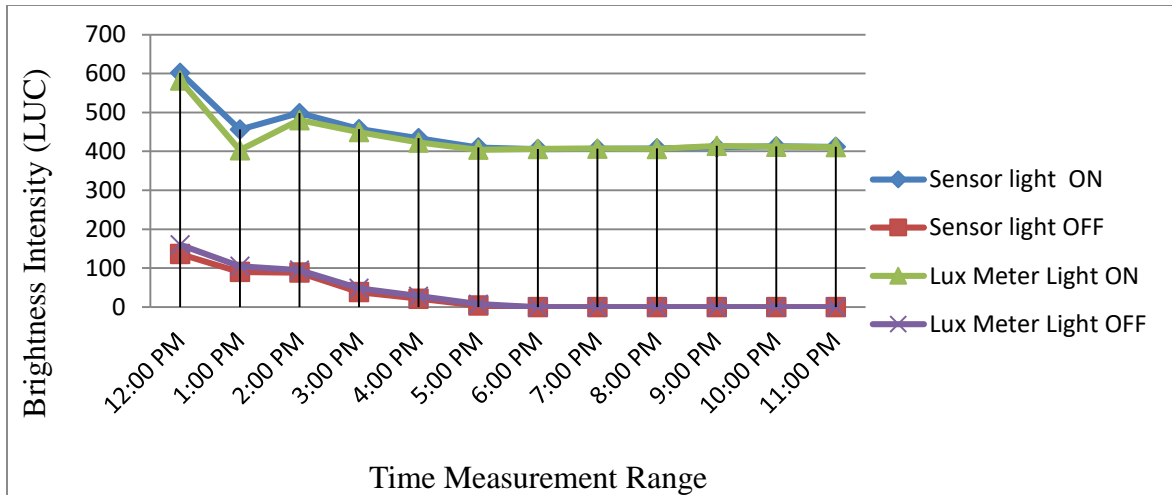

Figure 4-15 Comparison of second day's results for light intensity during daytime with and without light

Figure 4-15 illustrates the brightness intensity recorded by the light sensor and lux meter between 12:00 am and 11:00 pm, measured with the light ON and OFF on the second day. Ranges from 602 lux to 411 lux, and from 582 lux to 410 lux, were recorded by the light sensor and lux meter, respectively, over the period of time considered. There was a very slight difference in illuminance intensity because of the effects of changing weather and the location of the devices. When the light was OFF, just in the evening, the brightness recorded by both devices was reduced to a value of 0 lux between 6:00 pm and 11:00 pm.

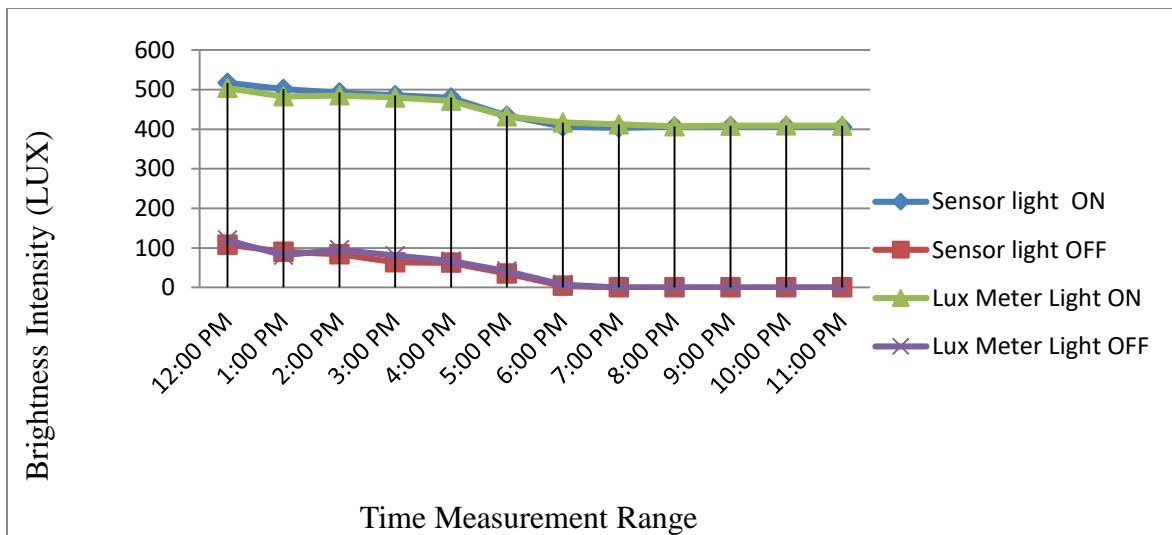

Figure 4-16 Comparison of third day's results for light intensity during daytime with light ON/OFF

## Experimental Configuration and Results

The line chart illustrated in Figure 4-16 shows the results recorded during the third day of the test. With the light ON, the results recorded using the light sensor and the lux meter ranged between 517 lux and 405 lux, and between 503 lux and 408 lux, respectively.

Overall, the light intensity tended to increase during the period when the light was ON, as well as when the weather was sunny during the morning until the early evening period. The line chart values for both the light sensor and lux meter were significantly higher between 12:00 am and 5:00 pm than in the period between 6:00 am and 11:00 am, while the brightness was at its lowest when the light was OFF.

When comparing the line charts over the three days of the test, during the period from 12:00 am to 4:00 pm when the light was ON, the illuminance values recorded by the sensor were slightly higher than those recorded by the lux meter. The graph also shows the indoor light intensity during the afternoons after 5:00 pm without using any sources of light. For these conditions, the ranges recorded by both devices show approximately the same results, especially when used in a completely dark laboratory.

### **4.5 Distribution of context-aware information in the database**

Table 4-2 illustrates the database history of the smart home condition results from the prototype system, which includes eight sensors and a smartphone for monitoring and control of the electrical devices, as recorded in the lab environment. The computation should then proceed according to context-aware statistics-based rule computing, here with the scenario of elderly people. This section offers a variety of smart home context attributes, such as location, that can be gathered by various sensors such as the human body, obstacle avoidance and ultrasonic distance measurement sensors. The home environment was measured via temperature sensor, humidity sensor, brightness sensor and sound sensor, while the safety and security context could be calculated by the smoke sensor.

All smartphones and personal computers are capable of allowing customers to transfer context-aware results and information from other appliances in the prototype system to the database of the monitoring server. Information is transferred to the server with HTTP-protocol, and the context data are directed to the smartphone through TCP-protocol

## Experimental Configuration and Results

(Könönen & Mäntyjärvi, 2008). The architecture system design can also be extended to deal specifically with other kinds of links for communication-related information, and to handle context acknowledgement to the client. For instance, there may be Wi-Fly adapter communication between some technologies using the ad-hoc and infrastructure network.

Table 4-2 Records of Database history Context and Approved service

ID	Sud	Brn	Bdy	Ost	Hmt	Smk	Tmp	Dst	Location	Date/time	Approved Service
10084	Lu	MI	Hb	Lo	Hh	Ls	Ht	Cd	BR	2015-12-07 20:35:56	LF
10085	Lu	MI	Hb	Lo	Hh	Ls	Ht	Cd	LR	2015-12-07 20:36:01	FO
10083	Lu	MI	Hb	Lo	Hh	Ls	Ht	Cd	LR	2015-12-07 20:35:50	FO
10082	Lu	MI	Hb	Lo	Hh	Ls	Ht	Cd	LR	2015-12-07 20:35:44	LF
10081	Lu	MI	Hb	Lo	Hh	Ls	Ht	Cd	LR	2015-12-07 20:35:39	FO
10080	Lu	MI	Hb	Lo	Hh	Ls	Ht	Cd	BR	2015-12-07 20:35:36	LF
10079	Lu	MI	Hb	Lo	Hh	Ls	Ht	Cd	LR	2015-12-07 20:35:27	FO
10078	Lu	MI	Hb	Lo	Hh	Ls	Ht	Cd	LR	2015-12-07 20:35:22	LF
10077	Lu	MI	Hb	Lo	Hh	Ls	Ht	Cd	LR	2015-12-07 20:35:19	FO
10076	Lu	MI	Hb	Lo	Hh	Ls	Ht	Cd	BR	2015-12-07 20:35:10	LF
10075	Lu	MI	Lb	Ho	Hh	Ls	Ht	Cd	LR	2015-12-07 20:32:03	FO
10074	Lu	MI	Lb	Lo	Hh	Ls	Ht	Cd	LR	2015-12-07 20:32:01	LF
10073	Lu	MI	Lb	Ho	Hh	Ls	Ht	Cd	LR	2015-12-07 20:31:52	FO
10072	Lu	MI	Lb	Ho	Hh	Ls	Ht	Cd	BR	2015-12-07 20:31:46	LF
10071	Lu	MI	Lb	Ho	Hh	Ls	Ht	Cd	LR	2015-12-07 20:31:41	FO

## 4.6 Testing and Evaluation of Smartphone Applications

### 4.6.1 Mobile application interfaces

In the smart home system, the vital interface between the technological system and the user is a mobile application. This puts the user's commands into the system and gathers information regarding the smart home context by means of HTTP protocol, as well as SPLIT and POST functions. A sample database is shown in Figure 4-17. There is a login screen interface (a), a context monitor screen interface (b) and an interface displaying the status of both the devices and the interface (c). Sensors or actuators and a smartphone provide the means of home automation in the context-aware computation service prototype. This section provides a description of the iPhone Operating System (iOS) interface which implements the context-aware service by means of the functions in the suggested system. Sensing data

## Experimental Configuration and Results

is gathered first by the MCU and passed by the Wi-Fly to the smartphone. This is shown in Figure 4-17, which demonstrates the final observation derived from an experiment to test the efficacy of information collection from sensory equipment using an iPhone and Wi-Fly serial adapter (Ghabar & Lu, 2014). A smart home's interfaces are intended to provide:

- 1) Context-aware information regarding items and events by means of a Wi-Fly network connection
- 2) Monitoring, display and updating of the context
- 3) Remote context of home appliances in the context



(a) Main page

(b) Monitoring page

(c) Control page

Figure 4-17 Smartphone (iOS) application interface for smart home design

### 4.6.2 Sensor results using Tera Term and mobile phone

It was mentioned in sections 4.2.2 and 4.2.3 that there were two methods of setting up and configuring the gathering of sensor data using a wireless network; these were Tera Term and mobile phone. In order to display the collection of data from eight sensors via an ad-hoc network, it was important to test the output data from each sensor according to the functionality of each sensor. Therefore, these experiments were conducted before sending

## Experimental Configuration and Results

the data to the database history. Due to the nature of the embedded sensors, context data acquisition can be achieved by different sensor functions that can be located in the smart home environment. For instance, the obstacle, human body, smoke, sound and humidity sensors express their results in a digital format, comprising factors whereby the output turns to '1' from '0'. However, temperature, brightness and ultrasonic distance measurement provides discrete acquisition of continuous signals which are produced in an integer format. Table 4-3 shows a comparison between the expected output data of each sensor and the actual output results, which are shown in the two columns of the table. This test also allowed the researcher to determine whether all the sensors could be used to monitor the ambient environment and gather accurate output results according to the functional characteristics stated in Appendix B, Table Ab-1. Generally, the results from all output sensors show very high accuracy according to the function of each sensor (Ghabar & Lu, 2014).

Table 4-3 Test and expected results (Ghabar & Lu, 2014)

Sensor Type	Function	Methods		Expected	Results
		Tera Term	iPhone		
<b>Sound</b>	Detecting whether voice is low or high	✓	✓	0 or 1	0
<b>Obstacle</b>	Avoidance of an obstacle or object in line	✓	✓	0 or 1	1
<b>Human body</b>	Human body sensing	✓	✓	0 or 1	1
<b>Smoke</b>	Detection of gas and smoke	✓	✓	0 or 1	0
<b>Humidity</b>	Humidity and raindrop detection	✓	✓	0 or 1	0
<b>Light</b>	Measurement of light intensity	✓	✓	(0 - 1000 ) Lux	(0 - 753 ) lux
<b>Temperature</b>	Measurement of room temperature	✓	✓	(3 - 40) °C	(19.18 - 24.87)°C
<b>Distance</b>	Measurement of current distance	✓	✓	(0.2cm - 4m)	(0.2- 60) cm

### 4.6.3 Monitoring environment

With the aim of investigating the performance of the mobile phone applications, for example in monitoring the situation of the ambient environment, the iPhone was used to test the acquisition of embedded sensor data. This investigation was conducted within a real-time

## Experimental Configuration and Results

environment. The experiment was focused on the time required for the process of gathering the sensor data via a wireless adapter from various different distances in the corridor. The mobile phone was connected to the CF socket through an ad-hoc wireless network, and once the wireless sensors were connected with the TCP/IP socket, an indication that the network was connected was given by the notification 'Connection is successful'. The monitoring of the data gathering process would begin when a successful connection had been established. Figure 4-18 shows the results of the experiment that was done at a series of five-metre distances, and repeated five times. After completing the test for each distance, the iPhone was restarted when the smartphone user moved to another new location. The distance of the measurements ranged from one metre to 25 metres, and the data was gathered for each five-metre distance with five repetitions, with a view to measuring the average time consumed. When the distance was closest to the fixed point, the time consumed was recorded as between 5 milliseconds and 5.7 milliseconds, but once the distance increased to 15 metres, the time consumed was approximately 5.7 milliseconds. The time consumption for 25 m, however, was between 5.8 and 5.9 milliseconds, which is too long. This would not be suitable for use in gathering data that had to be adapted for the iPhone application server. However, the performance of 0.057 seconds would be suitable for the long-range remote testing server when the distance was more than 25 metres. In other words, the performance of the Wi-Fly in testing the monitoring environment by mobile phone was found to be highly sensitive to distance. When the distance was increased, the time consumed increased significantly (Ghabar & Lu, 2015).

## Experimental Configuration and Results

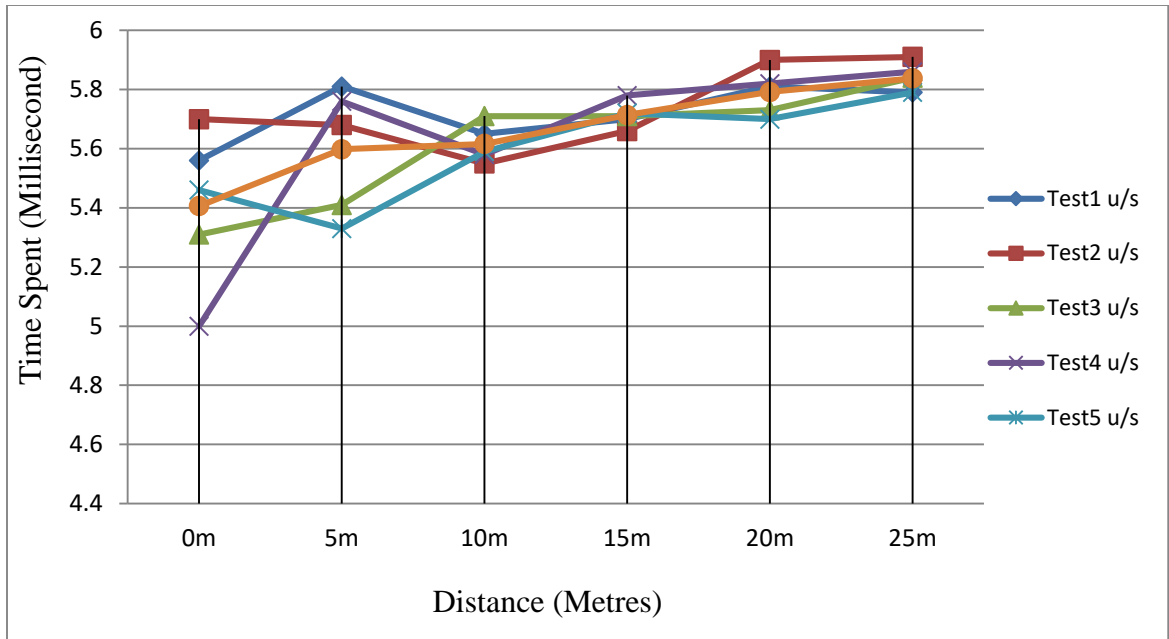

Figure 4-18 Time spent using touch screen to monitor environment

Figure 4-19 shows an evaluation of the results of home environment monitoring using eight sensors and different locations, times and IDs. The average response time using the Wi-Fly 802.11 b/g serial adapter and iPhone smartphone was 5.406  $\mu$ s at a distance of 0 cm, which increased to 5.838  $\mu$ s at a distance of 25m. The signal strength then began to decrease at a distance of 27m (Ghabar & Lu, 2015).

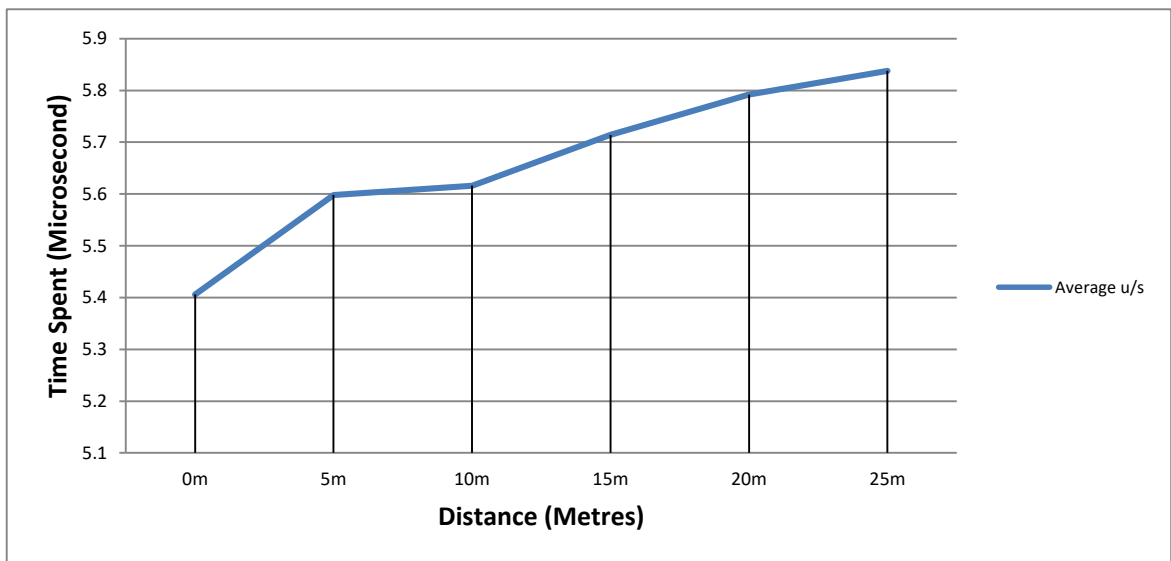

Figure 4-19 Average time spent using touch screen to monitor environment

## Experimental Configuration and Results

### 4.6.4 Device control

For the home automation function, the performance of the prototype system was able to reach a distance of up to 30m. All the devices could be controlled from 5m to 30m, but after that the system only gained a response from some of the devices, i.e. LED1 and LED2 (Ghabar & Lu, 2015).

Table 4-4 Test results for home automation (Ghabar & Lu, 2015)

Distance	5m	10m	15m	20m	25m	30M
All Devices	✓	✓	✓	✓	✓	X
Fan1	✓	✓	✓	✓	✓	X
Fan2	✓	✓	✓	✓	✓	X
LED1	✓	✓	✓	✓	✓	✓
LED2	✓	✓	✓	✓	✓	✓

(Note: ✓ represents acceptable action, x not acceptable action)

Table 4-4 illustrates the control of four electronic appliances, comprising two fans and two LED lights, using a mobile phone, the Apple iOS 6. It was observed that most of the devices responded to the smartphone function from distances of between 5m and 25m, as shown by the ✓ symbol. However, when the distance increased to 30m, some devices were unable to respond to the action command, as shown by the symbol x. The test focused mainly on functionality and distance (Ghabar & Lu, 2015).

### 4.6.5 The Concepts of Smartphone Appliances Applications:

A weakness of smartphone devices, based on mobile phone applications is that the device must remain lightweight and uncomplicated. The mobile device limitation is essentially reflected in different ways as screen size, computing power, available communication bandwidth and Human Computer Interaction capability (Meng & Lu, 2015; Vazirgiannis, 2006). As a result, various new methods and technologies have been elaborated to enhance the HCI ability of smartphone applications, as well as improving the efficiency of communication resources and computing services. The following aspects for mobile appliances have been characterized such as:



## Experimental Configuration and Results

- 1- Easy to use and appropriate for all the users
- 2- Can be connected with different kinds of sensor technologies
- 3- Enhanced and attractive appearance of the user interface
- 4- Open to World Wide Web resources and very easy to communicate via wireless technologies.
- 5- Limits of input information presentation

These concepts make a distinction the context-aware smartphone application from their traditional coordinate based on computers system. Only through comprehensive consideration of these concepts can the valuation guidelines for context-aware smartphone implementation be specified.

### 4.7 Summary

This chapter has explored the results achieved from the experiments. The results demonstrate three methods of data collection from various sensors with different purposes, and illustrate the first step in this research. The three methods presented were firstly, the serial port tester, which is wired technology; secondly, the Wi-Fly serial port tester, which is wireless technology; and lastly, iPhone technology using an ad-hoc applications interface. It was then necessary to determine which technology would be best suited for use by the elderly in the smart home. Since the elderly appreciate simplicity in the home, wired technology would not appear to be the most suitable prototype; this simplicity would probably be best achieved by the wireless adapter and iPhone methods.

As the collected data show, two methods of sensor observation have been used. Firstly, five of the sensors express their results in a digital format, comprising factors of zero and one, while secondly, the temperature sensors produce results in an integer format. Combinations of the two methods, with a fusion of their data, are provided from information in a smart home environment. Chapter 5 will investigate the statistics-based rule for a context-aware data history, the context-aware automated service, and a high-layer regulator for context-aware implementation. When a successful outcome has been achieved in the first step, the next stage of the work will be to improve the model to make it more suitable.

## **Chapter 5 Statistic-based Rule Computation for Context-Aware Automated Service**

The general model for a context-aware service and information representation, which normalises the context data and establishes the physical relationship between low-level and high-level decisions, is shown in section two of Chapter 3. This chapter provides the rules that can be applied at the higher level, at the point where the context information is transferred from low level to high level. The context information will be acquired from the sensing environment and can be used directly for context update. Data abstraction can be considered as a pre-processing of this raw sensor information. Next, the heterogeneous information content can be standardised, so that it can accept a context-aware application using a formal structure. Generally, data incorporation is built on context-aware applications to be centralised within the system design. As the focus of this thesis is the creation of a context-aware automated service, some statistics-based rules are applied to the detection and extraction of data. These methods are employed because of their light weight, simplicity and high level of performance.

The case study scenario includes the use of smartphone interfaces to improve the time consumption and efficiency of the mobile computing service. However, such mobile devices have limited resources as mentioned in chapter 4, section 4.6.5, which forces the utilisation of a mobile computing service with connected sensor technologies to predict the opportunities for automatic control of electrical devices (Meng & Lu, 2015). According to previous studies mentioned in Chapter 2, the nonexistence of a comprehensive prototype system design could be seen as a practical difficulty in approaching this area of context-aware mobile computing. Despite the integration of mobile detection technology to improve the efficiency and time complexity of mobile applications, resource limitations remain. Therefore, it is important to establish the design and implementation of a comprehensive and adaptable prototype model for a context-aware mobile computing service. Chapter 3 described the implementation of a mobile device for two interface applications. The first is to retrieve and gather information from the smart-home situation through embedded sensors with different functions, while the second is as a remote controller for the home facilities

according to context data monitoring. In the next section, different methods and functions are presented to define the relationship between resident, context database history and context-aware computing applications in the system architecture model.

### **5.1 Context-Aware Abstraction and Incorporation**

The combination of context-aware data from various sources can be applied as an integration process. This enables the development of a model system characterised for context-aware service re-working (Lenzerini, 2002). As mentioned in the implementation section (section 3.6.10 of Chapter 3), the context-aware information is obstructed by different item attributes being conditionally independent according to the Naïve Bayesian classifier method, and by heterogeneous inconsistency. The statistical-based rule can create a considerable number of new data attributes that should be weighted and organised within the user-represented application (Castillejo, Almeida, López-de-Ípina, & Chen, 2014). A recent study has shown that a machine-learning method with decision-making rules in the high layer of a computing service is a very significant development, and is beneficial for use in advanced context-aware applications (Isinkaye et al., 2015). However, researchers Meng and Lu (2015) state that an inability to integrate the broad variety of context-aware sources by means of any particular technique is a common problem for context-unification in general. Therefore, with the purpose of making the service able to adapt to dynamic conditions, a statistics-based rule must be engaged for the computing service. Subsequently, critical problems in context-aware system progress, for instance weighted items and context access control, will be addressed.

This area of the research supports by weighting attributes so that context-aware service variation can be integrated into a context-aware automated service by extracting heterogeneous information from sources. These implementations of context-aware abstraction and integration enable raw sensor data to be converted into context data through high-level statistical rules, which make decisions appropriate to a computing service.

### 5.1.1 Context-Aware Abstraction using the Threshold-based Method

Raw context-aware data can commonly demonstrate particular fault attributes, which make them ineligible to be utilised precisely. More specifically, a few of the raw data may need more accuracy than the performance of the sensors can achieve. With the intention of increasing comfort in the intelligent building, all information needs to be categorised into different scales. For example, the data from the light sensor are used to measure the brightness event ranging between 0 and 65535 lux. It is not essential to deal with all of this information, however. What is important is to group this data into four values using a decision-making logic rule as IF and ELSE conditions, and to describe these values as Low, Medium, High and Very high. Although several items of context-aware data may be utilised precisely for context update, the results of the context attributes must be characterised according to the specific context. For example, the context data for the obstacle avoidance sensor, the human body sensor, the humidity sensor and the smoke sensor values can be defined as:

$$C_{Obstacle\_Human\_Humidity\_Smoke} = \begin{cases} 1, & \text{something close to the sensing area} \\ 0, & \text{nothing close to the sensing area} \end{cases} \quad 5-1$$

$$f(x) = \begin{cases} 1, & X > \text{threshold} \\ 0, & \text{Otherwise} \end{cases} \quad 5-2$$

The threshold-based method is defined as “values that set a cut-off in a range” (Wazir Zada Khan et al., 2013); nevertheless, some context information may not be directly collected from the sensor devices and can only be abstracted by computing from the raw data (Kurihara et al., 2013). Most of the intensive computing of context-aware data is performed by the client device or microcontroller unit. Therefore, the threshold function can set a specific level of utilisation according to the context data. This permits the user to achieve conditional behaviours whereby a certain sensor value declines in relation to the threshold. For example, temperature sensor values can be set from 0 °C to 40 °C, brightness sensor values can be set between 0 and 65535 Lux, and ultrasonic distance measurement can be set from 2cm to 400cm. These may be separated as follows:

**1. Temperature sensor**

$$V_{Temperature} = (Low < 10 ; 10 \leq Medium < 19.9; 20 \leq High < 29.9; Very\ high \geq 30) \quad 5-3$$

**2. Brightness sensor**

$$V_{Brightness} (Low < 100 ; 100 \leq Medium < 200; 200 \leq High 1000; Very\ high \geq 1000) \quad 5-4$$

**3. Ultrasonic distance measurement sensor**

$$V_{Ultrasonic\ distance} = (Close\ distance < 50cm; 51cm \leq Near\ distance \leq 100cm ; Far\ distance > 100cm) \quad 5-5$$

**5.1.2 Context-Aware Information Incorporation Frameworks**

Information abstraction may be regarded as a pre-processing storage procedure for the raw context-sensor information. Thereafter, the multiple, heterogeneous context information may be regularised by an explicit architecture which is acceptable for use by a context-aware framework. Typically, raw context data incorporation depends on a centralised model for a context-aware framework. The context-sensing information is gathered, and attributes extraction is implemented by the appropriate embedded system and smartphone client. After that, the formalised context architecture is also stored in the service’s database history.

In order to convert the constructed context data into an effective form for information retrieval using context reasoning and computing services, the attributes in the context aware situation and context items characterising them must be clearly defined in the framework. The model for context incorporation is illustrated in Figure 5-1.

## Statistic-based Rule Computation for Context-Aware Automated Service

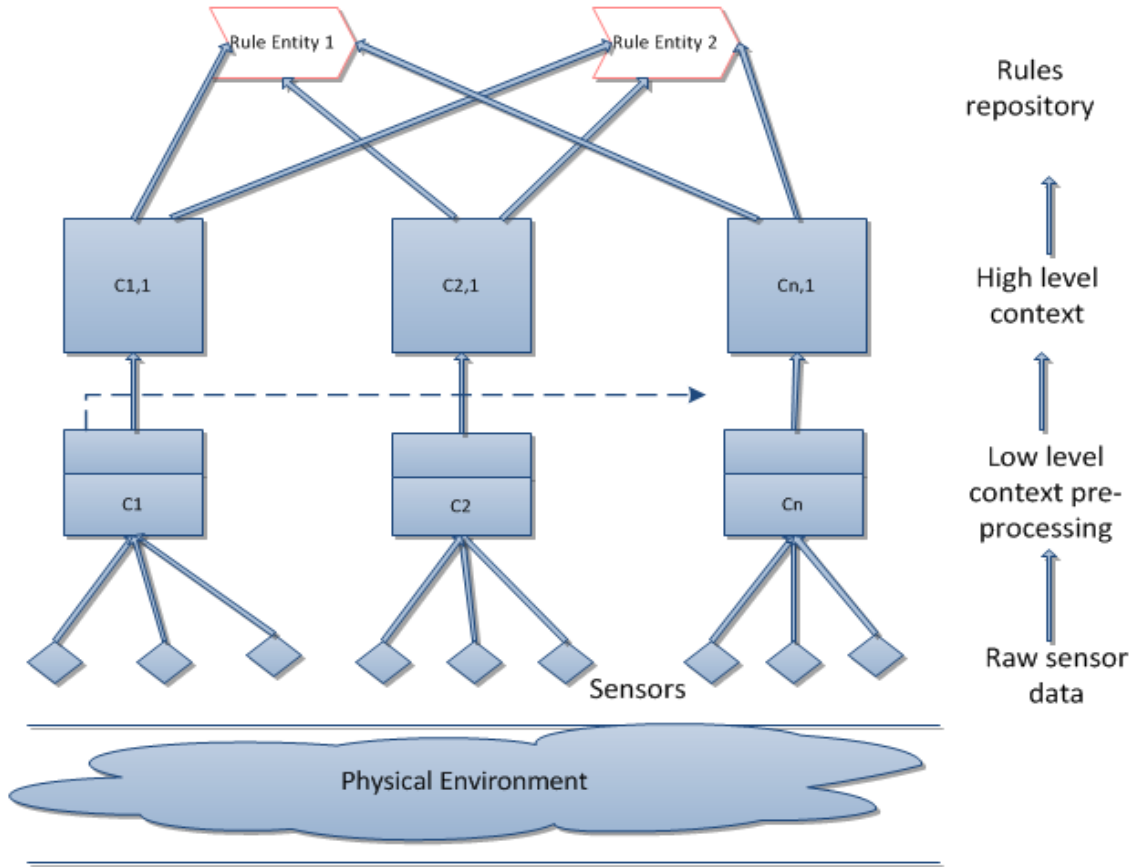

Figure 5-1 Context incorporation framework

The raw data from all sensor technologies needs to be pre-processed in order to obtain high-level context rules. The structure of the context incorporation framework includes a rules repository, feature abstraction and context pre-processing to acquire the various levels of context information.

### 5.1.3 Context-Aware Reasoning from Physical Layer to Decision Layer

The consistency of context-aware attributes, which are utilised as context reasoning in the input system, should be initially normalised as described in section 5.1.1. Context-aware reasoning has been defined as the relationship between the physical layer (low level) and the decision layer (high level), and is based on computation methods such as statistical and classification techniques, as shown in Figure 5-2.

## Statistic-based Rule Computation for Context-Aware Automated Service

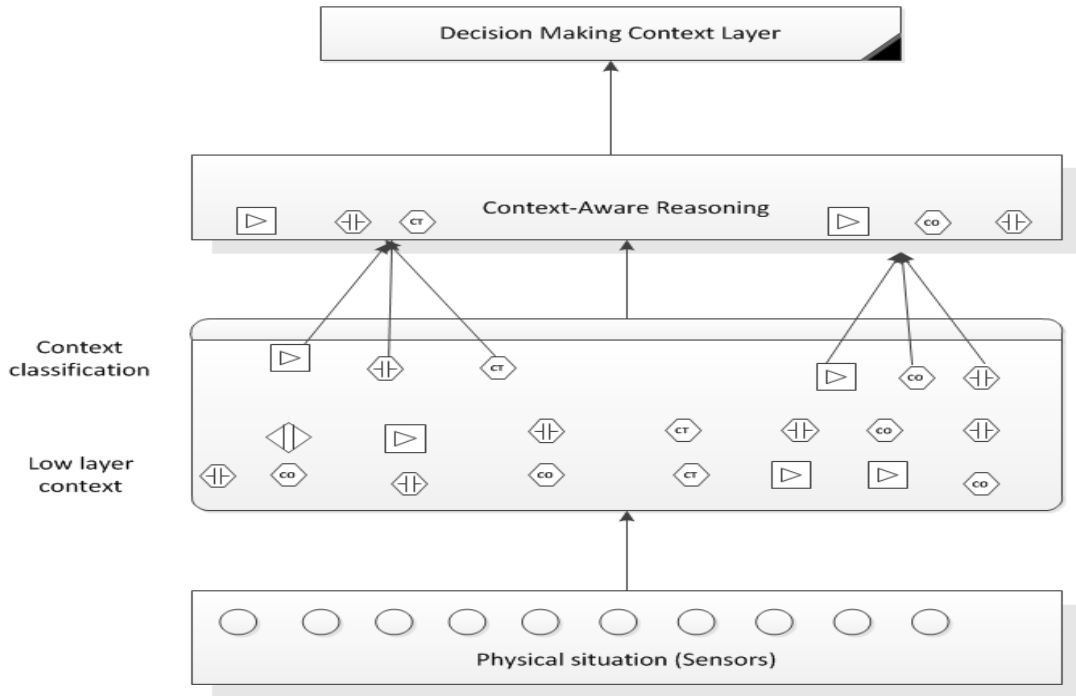

Figure 5-2 Basic plan of context-aware reasoning

Figure 5-3 shows that the context data acquired from low-level sensor devices can be normalised and classified in an architecture format. In the high layer, context data can be achieved using a context reasoning model. In this part of the study, the statistics-based context reasoning rule is presented, which is identified as follows. The weighting method is based on IR outcome ranking, where a ranking attribute involves an arranged set of context items. Each context attribute consists of the values of relevant items  $C_{in}$ . The defined set is  $C_1 = [C_{11}, C_{12}, \dots, C_{1n}]$  and  $C_2 = [C_{21}, C_{22}, \dots, C_{2n}]$  for each context attribute with  $n$  ( $n > 1$ ) items, and the values of each attribute should be of a defined weight  $0 \leq W \leq 1$ , where  $W$  represents the ranking result for the relevance of the context item. If the weighted attribute is defined as the weight of the context items  $C_i$ , then the high-layer context weight  $W_i$  can be deduced, with the relevant context items' value set using the formula (5-13).

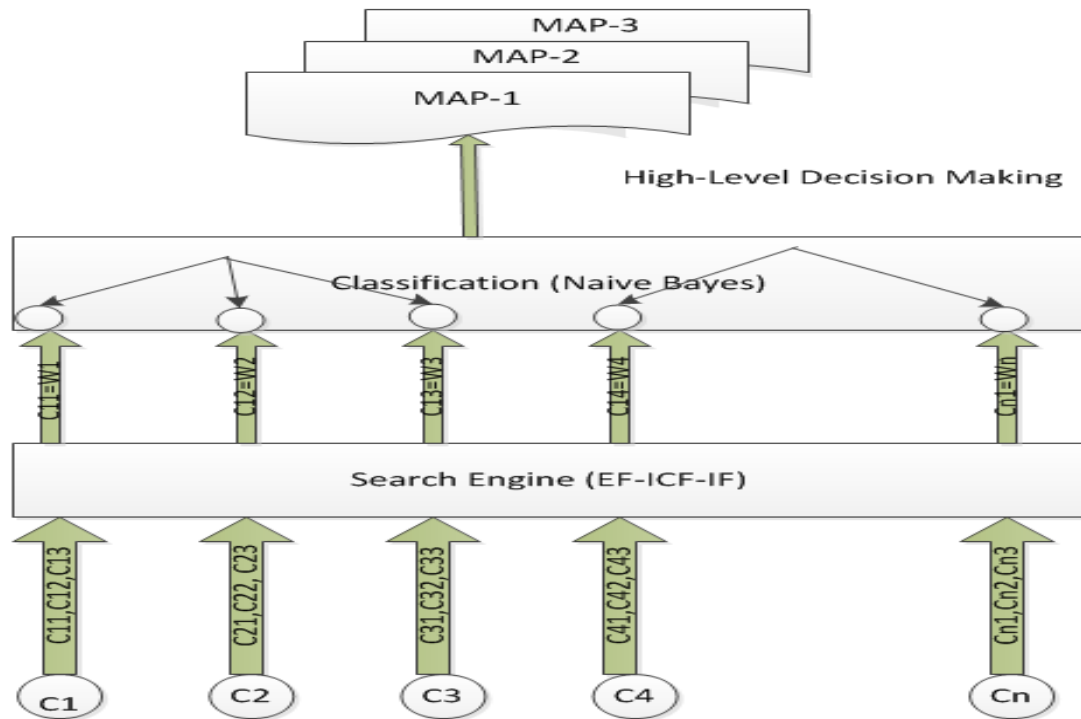

Figure 5-3 High-level classification of context data

## 5.2 Context-Aware Computing Service

In the case of the existing system, a number of steps are required to define the essential mathematical task of the statistical-based rule, which will predict the initial residents' requirements and thus provide appropriate decision-making. The main target of the context-aware model is to be responsible for the probability computing service. The idea of this model is to minimise user influence in the smart home application by developing a complete consciousness of the context environment. This system architecture gives a framework for context awareness which enables the provision of a computing service. In order to achieve the context-aware automated service, with effective decision making based on the database history, a combination of EF-ICF-IF and Naïve Bayesian methods has been suggested. Furthermore, in order to produce an executing service which functions within a dynamic situation, Naïve Bayes decision making based on weighted terms is used to observe which important information should be involved in a maximum-likelihood method.



## Statistic-based Rule Computation for Context-Aware Automated Service

In recent years, there has been an increasing volume of studies of context-aware computing services (Meng & Lu, 2015; Weiser, 1991), including those with particular reference to smart home applications (Makonin et al., 2013). These recent studies describe a method called Smart Intervention (SI) that offers the fundamental function of context-awareness, which is to compute residents' expectations and pro-actively decide on actions to arrange a suitable service accordingly. Makonin and Popowich (2014) presented a method called a Smart Intervention (SI); this function involved: residents requirements, home, context, and measurements. The devices used in this module included: sensors, actuator and wireless network. Formula (5-6) below has been used in experiment to control the light in the middle of the night when the occupants get out of bed. It was found that this system design has the benefit of permitting the functionality to be extensible and flexible in the smart home, and it can be developed for many other numbers of reasons (Ghabar & Lu, 2014). According to various publications, in performing the calculation, the context-aware computing service in the smart home is defined as  $H_{SC}$ , the occupants' explicit demands  $O_{ED}$ , and the computing of context information,  $C_{CI}$ . In addition,  $A_{ut}$  is automation and  $E$  is evaluation for accuracy and effectiveness.

These studies present the practical application of a context-aware computing model to work with Smart Intervention (SI) as in equation 5-6. The function is,

$$H_{SC} = SI(O_{ED}, C_{CI}, A_{ut}, E) \quad 5-6$$

In addition, according to the computing rules, the model should expect the service to deal automatically with problems in the intelligent building's context-aware information, as in equation 5-7.

The formula is,

$$H_{SC} = SI(O_{ED}, A_{ut}) = SI(C_{CI}, A_{ut}) \quad 5-7$$

The computing of context-aware information involves various tasks. For instance, the human context can be sensed with different sensor technologies such as the human body context, obstacle avoidance context and ultrasonic measurements context, which can be represented as  $C_{OC} = [C_{HB}, C_{OA}, C_{UM}]$ . Similarly, the home environment can be sensed through factors including the humidity context, temperature context, brightness context,

### Statistic-based Rule Computation for Context-Aware Automated Service

sound context and smoke context, such that  $C_{HE} = [C_H, C_T, C_B, C_S, C_{SM}]$ . The devices context should also be considered, such as mobile phone context and actuators context,  $C_D = [C_M, C_A]$ .

Therefore, from formulas 5-6 and 5-7 a general formula for a context-aware computing service can be written (5-8):

$$H_{SC} = SI(C_{CI}) \text{ where } C_{CI} = [C_{OC}, C_{HE}, C_D \dots] \quad 5-8$$

The contextual awareness of the decision-making in the initial service is realised by the statistical search engine according to the weighted items. The EF-ICF-IF search engine algorithm can be considered a context-aware information intervention model that works with input data and generates probability-based rule features. The method can be supervised by the computing service through a maximum likelihood decision-making service. The fundamental principles of the statistical features of the contextual search engine combined with Naïve Bayesian decision-making can be described using the following theoretical model.

Consistent with the computing service model, a statistical, context-aware automated service rule is proposed in Figure 5-4, where  $A_I$  is the occupant's request and contextual items  $CC_I$  are the conditionally independent requirements for a Naïve Bayesian decision-making algorithm, which is affected by the smart home facilities.

- 1- In the probability-based context aware decision-making service, the contextual computation service is combined with a condition decision rule using the Naïve Bayesian network.
- 2- Maximum probability is utilised to make appropriate decisions for the computing service using the contextual database history

## Statistic-based Rule Computation for Context-Aware Automated Service

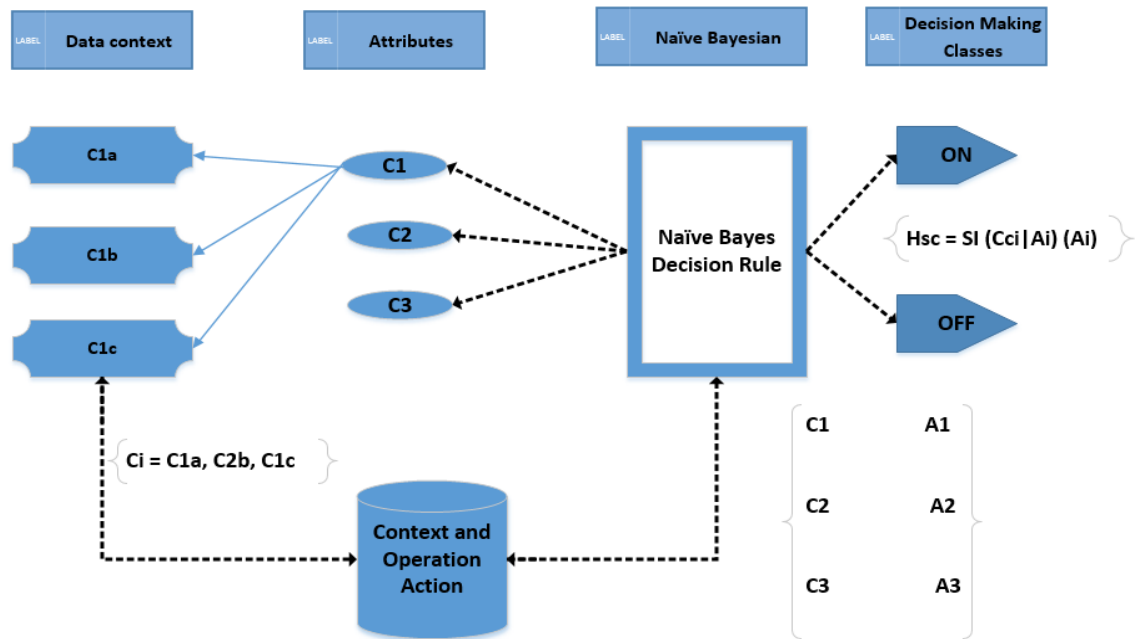

Figure 5-4 Comprehensive model of multiple contextual services attributes for enhanced Naïve Bayes decision making

### 5.2.1 Derivation of Context-Aware Item Weights using EF-ICF-IF

Statistics-based rule methods using context-aware information start with the retrieval of data from the database history by building pages and dividing each page into rows; each row contains all the values of the sensors used in the monitoring of the smart home environment, in order to find which term has the highest weight. For example, the temperature sensor has four values: low (Lt), medium (Mt), High (Ht) and very high (VHt), with the same technique of collecting information being used for the other sensors. The essentials of implementing the search engine using an EF-ICF-IF algorithm are that the EF-ICF-IF term weight can be extended to enable the database to work with the page of context-aware information rather than documents. Each page consists of 30 rows, but each line has different values of sensor data and this can be used to characterise the context-aware features.

An attempt was then made to study whether context-aware term weight methods, which had been modified from the standard TF-IDF principle and adapted to the specific situation in

## Statistic-based Rule Computation for Context-Aware Automated Service

the smart home environment, could assist the accuracy of the home automation decision-making service. The process is described below.

Step 1: First, the usage of context items is computed based on the total number of rows obtainable and the items required for each page, according to these attributes:

$$C = \{C1 = C_{Sud}, C2 = C_{Brn}, C3 = C_{Ost}, C4 = C_{Hmt}, C5 = C_{Smk}, C6 = C_{Tmp} \dots C_N\} \quad 5-9$$

Step 2: Then, the parameters which characterise the number of each variable are calculated and the entire context value is displayed at the top of the current page. Because each attribute is context aware, the calculation of information has different values; for example, brightness and temperature,  $C_{Bm} = (c_{Lb}, c_{Mb}, c_{Hb})$  and  $C_{Tmp} = (c_{Lt}, c_{Mt}, c_{Ht}, c_{Vht})$ , are implicit terms of input C.

At this point, the calculation of all value attributes for each item of sensor data is exhibited, and a full table is created in order for them to be invoked in the EF-ICF-IF algorithm, as described in the following cases.

Step 3: Hereafter, the first parameter in the information retrieval weighting structure for Event Frequency is presented using formula 5-10 (Reed et al., 2006):

$$EF_{ij} = 0.5 + \left( \frac{0.5 * C_{ij}}{\sum_k C_{ik}} \right) \quad 5-10$$

where  $EF_{ij}$  is the frequency of the appearance of a context-aware event, incidence  $i$ , on page  $j$ ;  $C_{ij}$  is the number of context items  $i$  on page  $j$ ; and  $C_{ik}$  is the sum of all context items  $k$  on page  $j$ .

Step 4: The second parameter represents the inverse context frequency ICF, as adopted in equation 5-11 (Kurihara et al., 2013):

$$ICF = \log_{10} \left( \frac{N_{cj}}{n_{ci}} \right) + 1 \quad 5-11$$

Based on the formula above, regardless of the value of ICF, if  $N = n$  then there will be a result of '0' for the calculation of ICF. To that can be added the ICF value '1' as the second term, so that the weight calculation will be as follows: where ICF is the inverse context frequency of context items in all rows,  $N_{cj}$  is the total number of context items on the database pages and  $n_{ci}$  is the total number containing the context item  $j$  on all pages.

### Statistic-based Rule Computation for Context-Aware Automated Service

Step 5: The final parameter is context Item Frequency (IF), which represents the frequency of each context item across all pages. This is calculated in order to find the accuracy of the state's weight when the database pages are viewed, as adopted in equation 5-12:

$$IF = \frac{n_{ci}}{N_{cj}} \quad 5-12$$

Based on the above steps for calculating the total weight value of the context data, the total parameters become as in equation 5-13:

$$W_{ij} = EF * ICF * IF = 0.5 + \left( \frac{0.5 * C_{ij}}{\sum_k C_{kj}} \right) * \log_{10} \left( \frac{N_{ci}}{n_{cj}} \right) + 1 * \frac{n_{ci}}{N_{cj}} \quad 5-13$$

where  $W_{ij}$  is the weight of context-aware item  $C_i$  on page  $C_j$ ;  $EF_{ij}$  is the number of occurrences of the context-aware item  $C_i$  on page  $j$ ;  $N_{cj}$  characterises the number of all rows with context-aware attribute  $C$  on page  $j$  in the database; and  $n_{ci}$  characterises the number of context-aware items containing the context item  $C_i$  on each page. This algorithm can be normalised by formula 5-13 with the aim of standardising the value weights into the interval  $\{0 \leq W_{ij} \leq 1\}$ . The EF-ICF-IF calculation above shows how a context-aware item's weight is important to monitoring the smart home environment using a search engine. It can be seen that the less frequently a context-aware item is found on the page, the less important the monitoring situation is, while a more frequent occurrence indicates a greater significance of this item. Therefore, the differing weight of items on the page will provide greater evidence to ensure accuracy in the information retrieval data.

The EF-ICF-IF is used to retrieve important information from the context items in each attribute. This process can be improved by discarding inappropriate information and focusing only on the most significant context items. These items then become outcomes in the top positions of the higher ranking, as shown in Table Ab-1, Appendix C. In the decision-making domain of a context data-monitoring situation using features from different sensors, the key for each character string is defined as the total content of each attribute. As a result, the total weight of each context item in the database history is the multiplication of  $W_{ij} = EF_{i,j} * ICF * IF$ . As stated above, this  $W_{ij}$  can be included as the item frequency (IF), which improves the approach for linking the weight of the context item information with the class

## Statistic-based Rule Computation for Context-Aware Automated Service

action information. The reason for this is that the new improved method increases the rank of each context item, and the total weights of the context items of each attribute are situated in the range between 0 and 1.

The more one context item creates an impression, by having a higher weight, on one class action in the context-aware database, the more significant that context item will be in characterising that class action. The computation in this procedure is designed only to compute the weight of, and ranking between, the context attributes and a limited number of context items in the MAP. The context items are expected to be applicable to the description of the features of the attribute. In addition, the computational load of applying the decision-making through a statistical-based rule makes it lightweight and easy to implement.

### 5.2.2 Pseudocode Algorithm for EF-ICF-IF

To create a context-aware home automation computing service, a Pseudocode structure must be designed according to probability-based rules. This is an easy method of defining a set of directives without using exact code, and can be adapted for various programming languages. For the statistics-based personalisation rule, the main objective is to determine the convenient weight attribute of items and select the high frequency attributes using the EF-ICF-IF search engine. The programme below is the Pseudocode for the EF-ICF-IF algorithm to measure the weighted value according to the term frequency of each context-aware attribute in the database history. These values will be used with the Naïve Bayes decision service in the smart home system architecture.

#### **Algorithm 1: Extraction of context-aware terms**

\*\*\*\*\*

Make a Database Connection

Read the data from Database and Save into Pagane context-aware database history

Close the Database Connection

Input: context aware items from database history sensors

Output: the weight of each item according to their attribute frequency.

**Step.1.** Calculation of the total number of each term's frequency

For example: Total Temperature High = Testo1List.Count(x => x. Tmp == "Ht");

## Statistic-based Rule Computation for Context-Aware Automated Service

**Step.2.** Calculate weight of each attribute (Sound, Light, Human body, Obstacle avoidance, Humidity, Smoke, Temperature, Distance and Location)

For (i = 1; i <Page Count + 1; i++)

Sound Low Page = Model.Testo1 List. To Paged List (i, page Size);

Total Sound Low in This Page = Sound Low Page. Count (x => x. Sud == "Lu");

If (total Sound Low in This Page > 0)

**Step.3.** Calculate the term frequency

EF = 0.5 + ((0.5 \*total Sound Low in This Page)/ (Sound Low Page. Count));

**Step.4.** Calculate inverse context frequency

ICF Helper1 = Math.Log10 (total Rows);

ICF Helper2 = Math.Log10 (total Sud Low);

ICF = ICF Helper1 - ICF Helper2 + 1;

**Step.5.** Calculate the total weight of each term frequency

Total Item Frequency Lu = (total Term Frequency Lu + ef / total Pages);

**Step.6.** Calculate class frequency

IF = (total Sud Low / total Rows);

Total Weight = (ef \* icf \* if);

**Step.7.** Calculate the total weight

Total Weight of Sud Low = (total Weight of Sud Low + ef\*icf\*if / total Pages);

.....

According to the general prototype system architecture, a context-aware item's weight is determined using a search engine such as EF-ICF-IF. The relation between the database service layer and the high-level layer which is generated using a search engine method can be expressed in hundreds of rows. These database rows need to be shown in multiple pages or documents. The main idea of using paging means context query results can be presented on different pages, rather than just displaying them all together in one long page. Splitting the rows into multiple pages makes it more convenient to retrieve the information; this approach means that the information is easy to save and requires less scrolling. In order to split the database history into this series of pages, it is firstly necessary to know how many rows in all there are in the database, how many rows in each page it is necessary to display, as well as to be able to retrieve the context item for each attribute. In this context database

## Statistic-based Rule Computation for Context-Aware Automated Service

history, there are 330 rows and each page shows 30 rows, which means there are 11 pages, as shown in Table 5-1. The paging is implemented in Apache MySQL using PHP, then displayed in Visual Studio (ASP.NET). The page format of the acquired context database history is structured as follows:

Table 5-1 shows the database history as page and documents

<b>Id</b>	<b>Ost</b>	<b>Bdy</b>	<b>Smk</b>	<b>Hmt</b>	<b>Sud</b>	<b>Brn</b>	<b>Tmp</b>	<b>Dst</b>	<b>datetime</b>	<b>location</b>	<b>device</b>
9734	Ho	Hb	Ls	Hh	Lu	Ll	Ht	Cd	04/12/2015 16:49:05	LR	FO
9735	Ho	Hb	Ls	Hh	Lu	Ll	Ht	Cd	04/12/2015 16:49:11	LR	FO
9736	Lo	Lb	Ls	Hh	Lu	Hl	Ht	Fd	04/12/2015 16:49:16	BR	WF
9737	Lo	Lb	Ls	Hh	Lu	Hl	Mt	Fd	04/12/2015 16:49:22	BR	FF
9738	Ho	Hb	Ls	Hh	Lu	Ll	Ht	Cd	04/12/2015 16:49:36	LR	WO
9739	Lo	Lb	Ls	Hh	Lu	Ml	Mt	Fd	04/12/2015 16:49:39	BR	FF
9740	Ho	Hb	Ls	Hh	Lu	Ll	Ht	Cd	04/12/2015 16:49:45	LR	WO
9741	Ho	Hb	Ls	Hh	Lu	Ll	Ht	Cd	04/12/2015 16:49:50	LR	WO
9742	Lo	Lb	Ls	Hh	Lu	Hl	Mt	Fd	04/12/2015 16:49:56	BR	FF
9743	Ho	Hb	Ls	Hh	Lu	Ll	Ht	Cd	04/12/2015 17:35:50	LR	WO

Step 1- GET: After displaying the results, it is necessary to link the database history to show any page.

```
($_GET ["page"])) {$page = $_GET ["page"];} else {$page=1;};
```

Step 2- LIMIT: The limit of database history on each page is 30 rows, so if the existing page is page 3, this means that the data runs from row 60 to 89. In addition, the required item needs to be selected, such as ‘Brightness Low (Brn=Ll)’:

```
SELECT COUNT (ID) AS num FROM sensordata WHERE Brn= 'Ll' ORDER BY 'Brn'
LIMIT 60, 89.
```

Step 3- CEIL: The ceil is used to calculate the number of pages with results; this is achieved by dividing the total number of rows by the number of rows per page:

```
$total_pages = ceil ($row ["num"] / $results_per_page).
```



### 5.2.3 Modelling System Performance through Naïve Bayesian Decision Making

This section examines the Naïve Bayesian decision theory, which has become a principles-based approach to dealing with uncertain data in an attempt to show the best outcome. It considers how this model architecture can be used to recognise the context awareness of sensor information, actuators and reasoning processes. When considering an architecture model of (n) attributes, as outlined in Chapter 5, sections 5.1.3 and 5.2, each attribute  $i \in [1, n]$  has  $d_i$  discrete attribute conditions (Bensi, 2010). For that reason, the total number of components of the system architecture is  $\prod_{i=1}^n d_i$ . This is based on the Bayes Network method, which relates to the concept of integrating all attributes and model conditions as a Naïve Bayes construction. In this construction, a single class node  $A_{\text{class system}}$  is characterised as a condition of the model, which can be defined as the product of all nodes characterising the condition of the attributes, thus creating a combined construction as illustrated in Figure 5-5.

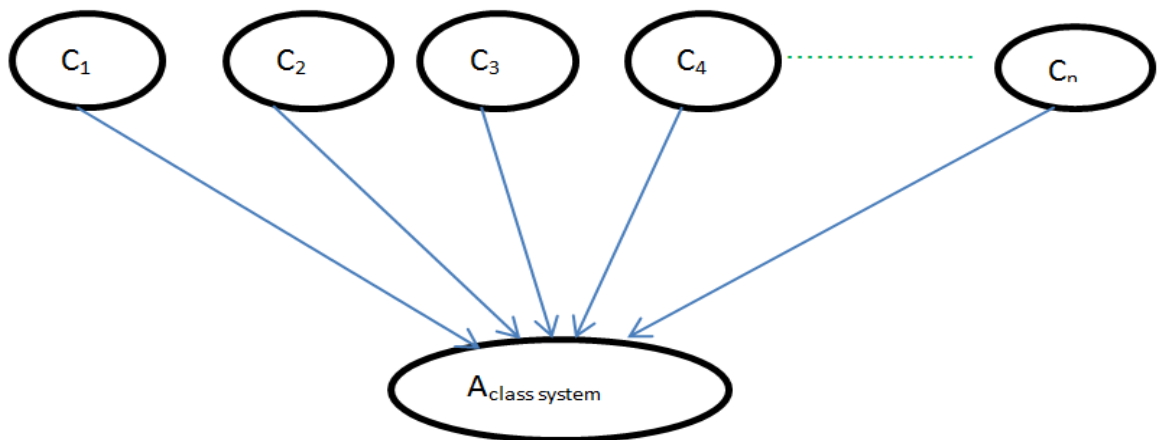

Figure 5-5 Naïve Bayes architecture model

The relation between the evidence and facts which are inputs from data sensors to be processed, and the events that are outputs from relays to process the action. In both conditions, it is necessary to calculate some attributes of instance that are independent from the input and output, for the purpose of prediction.

This system holds the essential hypothesis behind the Naïve Bayesian decision-making model, which states that each context-aware attribute must be conditionally independent of the other context attribute items that specify the state of the action decision independent

## Statistic-based Rule Computation for Context-Aware Automated Service

variable, which is the root in the branch model as mentioned in Figure 2-2. Having found a way of symbolising and operating with an emphasis on conditional independence, the next investigation must be how to improve the design model for decision making using the Naïve Bayes network.

The central idea is that a ‘belief probability’ can be a real number from ‘0’ to ‘1’, which shows the probability which is assigned to an event to be represented. The Bayes rule offers the theorem for calculating as follows:

$$P(A|C) = P(C|A)P(A)/P(C) \quad 5-14$$

For any two events, A and C can be stated as multipliers of one event probability P(C) by the probability of the second event occurring given that the first has occurred P(C|A).

In the real world environment, such a theorem can be applied to decision making. In applying the Naïve Bayes classifier to the context-aware home automation computing service, if the attribute is provided with label A as the state of the output (action), and label C as the sensors’ input, then the method can be represented as:

$$P(\text{action}|\text{sensors input}) = \frac{P(\text{sensors input} | \text{action}) P(\text{action})}{P(\text{sensors input})} \quad 5-15$$

The state of the action could characterise things that need to be achieved by devices, and the sensor input comes from different kinds of sensor data. From these sensors, information should be used to measure the statistical probability of various given states in the monitoring environment.

According to the general Bayesian rule, Naïve Bayes classification can be invoked for such situations as decision making for smart home automation. It is clear that Naïve Bayes decision making consists of two concepts. The first concept is used to enter the intuitive constituent of device states (actions) into the prior statistics simultaneously with the received sensory information. The second concept is that once the data sensor is established, transferred data can be processed as new data for probability, in order to calculate the likelihood of the new state. According to the Naïve Bayesian method, the likelihood is conditional on the sensors’ information and on independent actions; these provide the hypothesis information which can then be computed as P (sensors’ input | action). This

posterior value can be updated according to new information from the sensors. It is important to remember that the Naïve Bayesian approach can be defined as follows:

$$P(\text{outcome}|\text{evidence}) = \frac{P(\text{probability of evidence}) * P(\text{prior outcome})}{P(\text{evidence})} \quad 5-16$$

At the same time, there is a need to determine how to make a decision for each outcome consistent with the evidence, and how to allocate actions according to the highest probability. According to the explanation above, the Bayes rule can be utilised to create a common prototype for decision-making:

- 1- Decision-making is determined through classification: a set of features is specified (input data), then a target class (decision) is selected.
- 2- Decisions are built on the frequency of the classified features in the surroundings.

The general method of this prototypical Bayes network satisfies the simplifying expectations of Naïve Bayes decisions.

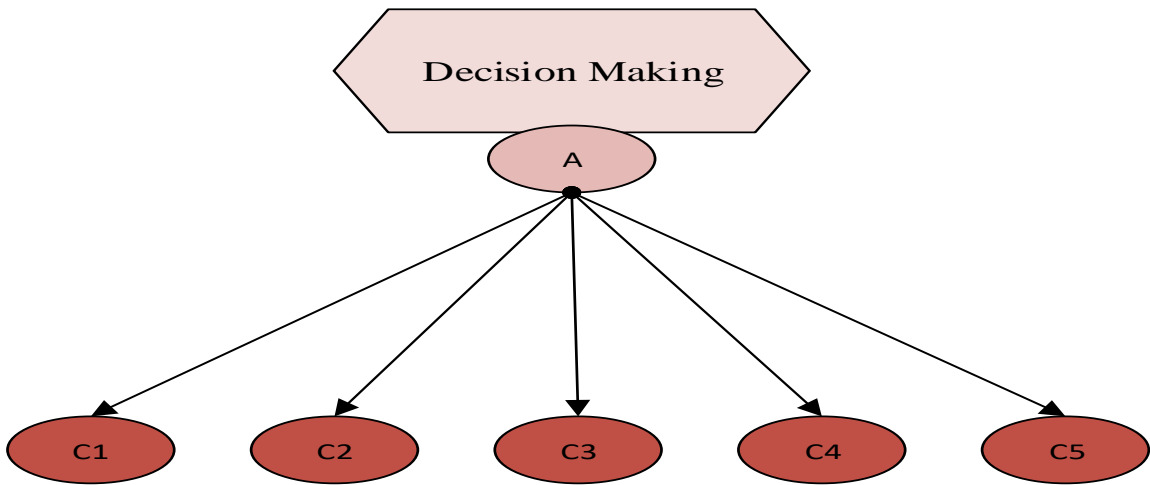

Figure 5-6 Construction of Naïve Bayesian decision making

Figure 5-6 represents the high-level computing attributes for the proposed context-aware service monitoring multiple context features in relation to residents' activity. This is achieved by weighting and ranking the frequency of items, using EF-ICF-IF to enhance the Naïve Bayes method in order to make appropriate decisions according to the smart home situation. The low-cost wireless sensors and actuators used for activity monitoring and home

automation services have been invoked, but for the context-aware computing service, certain concepts also need to be taken into consideration.

The Naïve Bayesian context-aware algorithm is a decision-making set of rules based on the Bayesian rule. It accepts that the context-aware attributes  $C_1, C_2, \dots, C_n$  are all conditionally independent of a single possible device action  $A$ . Furthermore, as (Mitchell., 2015) explains, “Given random variables  $A, C_1$  and  $C_2$ , we say  $A$  is conditionally independent of  $C_1$  given  $C_2$ , if and only if the probability distribution governing  $A$  is independent of the value of  $C_1$  given  $C_2$ ”. That is, Bayes declares the following relationship:

$$P(A=a|C_1, \dots, C_n) = P(A=a)P(C_1, \dots, C_n | A=a)/P(C_1, \dots, C_n) \quad 5-17$$

That rule gives the joint likelihood from the numerator value. Since each attribute is ‘naïve’, or conditionally independent of each other attribute, and  $a \neq j$ , this finds that derivation of Naive Bayesian algorithm as following:

$$P(A_a|C_j, C_k) = P(A_a|C_j) \quad 5-18$$

$$P(A_a|C_j, C_k, C_q) = P(A_a|C_j) \quad 5-19$$

Formulae 5-18 and 5-19 are used to classify the model for Naïve Bayes decision making, where  $A_a$  is the number of class actions involving switching on or off different devices, and  $C_j$  represents the context attributes from different feature values such as  $C_j, C_k$ , and  $C_q$

$$P(A_a|C_j, C_k, C_q, C_f) = P(A_a|C_j) \quad 5-20$$

Naïve Bayes is used in formula 5-20, which assumes that the attributes  $C_j, C_k, C_q$  and  $C_f$  are conditionally independent or do not affect each other given class  $A_a$ .

The joint method can be made explicit as:

$$P(A_a|C_1, C_2, C_3, \dots, C_n) \propto P(A_a) P(C_1|A_a) P(C_2|A_a) P(C_3|A_a) \quad 5-21$$

$$P(A_a|C_1, C_2, C_3, \dots, C_n) \propto P(A_a) \prod_{i=1}^n P(C_i|A_a) \quad 5-22$$

### Statistic-based Rule Computation for Context-Aware Automated Service

Each condition is independently computed with the chain method of the Naïve Bayesian theorem. It can be presumed that the conditional independence of C covers n aspects for specific values to another given A, for instance in this incident:

$$P(A = a_i | C_1 = c_{1i}, C_2 = c_{2i}, C_3 = c_{3i}) = P(C_1 = c_{1i} | A = a_i), P(C_2 = c_{2i} | A = a_i) \dots P(C_n = c_{ni} | A = a_i) \quad 5-23$$

Where the nodes attribute

$$C = \{C_1 = C_{Sud}, C_2 = C_{Brn}, C_3 = C_{Ost}, C_4 = C_{Hmt}, C_5 = C_{Smk}, C_6 = C_{Tmp}\} \quad 5-24$$

are context-aware data from the calculation of household tasks. For example, the data will include environment context, user context and time context, where the environment context information includes such elements as the brightness sensor context, humidity sensor context and temperature sensor context.

Since P (C<sub>Sud</sub>, C<sub>Brn</sub>, C<sub>Ost</sub>, C<sub>Hmt</sub>, C<sub>Smk</sub>, C<sub>Tmp</sub> ..... C<sub>n</sub>) is the context sensor information, this provides the input. These data are invoked from the database history according to new circumstances in the environment, and P (A=a<sub>i</sub>) gives the decision-making action probability. The value of this hypothesis is that it makes the demonstration of P (C|A) easier, and avoids the difficulty of approximating it from the database history. According to Naïve Bayes theory, a probability rule-based context-aware service can be simplified as in this rule: -

$$P(A = a_k | C_1, C_2 \dots \dots, C_n) = \frac{\prod_{i=1}^n P(C_i | A=a_k) P(A=a_k)}{P(C_1, C_2, \dots, C_n)} \quad 5-25$$

All of the studies involving Naïve Bayesian classification have disregarded the denominator and used the numerator only, which is equivalent to the conditional independence in the probability theorem and does not depend on evidence (Krishna & De, 2005; Seung-Hyun Lee et al., 2015; Shahi et al., 2015). However, in the case of probability rule-based decision making for context-aware home automation, the investigator should not neglect the denominator. It is, in fact, dependent on new data gathered from the home environment sensors after the data have been retrieved from the database history. The summation is

### Statistic-based Rule Computation for Context-Aware Automated Service

performed over the conceivable values  $a_j$  of  $A$  and  $C_i$ , the conditionally independent set of  $A$ . Therefore, the Naïve Bayes decision technique could be written as:

$$P(A = a_k | C_1, C_2, \dots, C_n) = \frac{\prod_{i=1}^n P(C_i | A = a_k) P(A = a_k)}{\sum_j P(A = a_j) \prod_i P(C_i | A = a_j)} \quad 5-26$$

where equation 5-26, the essential method of the Naïve Bayesian decision rule, gives the original case of  $C^{\text{new}} = C_1, C_2, \dots, C_n$ . This formula is used to compute the likelihood that a decision will make  $A$  achieve any given assessment value, thus giving:

$$P(A_a | C_1, C_2, \dots, C_n) = \frac{\prod_{i=1}^n P(C_i | A_a) P(C_2 | A_a) P(C_n | A_a) P(A_a)}{\prod_i P(C_1) P(C_2) P(C_n)} \quad 5-27$$

where  $C_1, \dots, C_n$  are items of the context-aware attribute;  $A_a$  is the set of classes used in the arrangement;  $P(C_n | A_a)$  is the conditional probability of class  $A$  given an action  $a$ ;  $P(A_a)$  is the prior likelihood of class action  $a$ ; and,  $P(C_n)$  is the set of input evidence.

The Maximum a Posteriori (MAP) estimate is used to assess the conditionally independent likelihood needed for an expert decision-making service based on this amount of context-aware data. However, the following simplified method can be used as an alternative.

This formula would be sufficient to reduce the complexity of a massive information acquisition rate in an expert decision service which relies on the conditional independence probability hypothesis. On the whole, if there is only a slight value of likelihood, or if there is a calculation error, the conditional independence probability will not be adequate.

This approach leads to each item of the attribute being given a specific class probability. After computing formula 5-27 for all conditions (classes) of  $A_a$ , the decision-making algorithm will compare all the results and select the option with the highest probability of being the appropriate action decision in the smart home automation setting.

$$P(A_a | C_1, C_2, \dots, C_n) = \underset{0 \leq P \leq 1}{\operatorname{argmax}} \left( \frac{\prod_{i=1}^n P(C_i | A_a) P(C_2 | A_a) P(C_n | A_a) P(A_a)}{\prod_i P(C_1) P(C_2) P(C_n)} \right) \quad 5-28$$

The calculation of maximum probability in Naïve Bayes decision making can result in a very small number as an explicit decimal value. This means that the outcome of computation

in some cases will be close to zero. Therefore, instead of maximising the products of likelihood, it may be better to use another formula to maximise the summation of their processes with the following rule:

$$P(A_a|C_1, C_2.. C_n) = \underset{0 \leq P \leq 1}{\operatorname{argmax}} \left( \frac{(\prod_{i=1}^n P(C_i|A_a) P(C_2|A_a) P(C_n|A_a)) + \log P(A_a)}{(\prod_i P(C_1) P(C_2) \dots P(C_n))} \right) \quad 5-29$$

The statistics-based rule service is based on the Naïve Bayes decision algorithm. However, it also builds in the application of the belief method, whereby the independent conditional probability of Naïve Bayes makes assumptions regarding the function of each set of supervised learning algorithms given a class variable A and the vectors of independent features C1 up to Cn.

#### 5.2.4 Algorithm for Naïve Bayesian Decision

The context attribute items are invoked for the computing decision-making service, and the probability-based method is employed to classify the maximum rule based on the context attribute items. With these codes, the model can offer a suitable calculating service adapted to the contextual conditions. The algorithm investigating the context-aware statistics for use in context-aware home automation is established. Although the context information is heterogeneous in construction and style of information, the set of algorithms can be considered through the involvement of an application that is general to the context-aware calculating environment. The statistics-based rule is measured as shown in Algorithm 2 below. The Naïve Bayesian decision-making method is designed to deal with context attributes by making suitable decisions according to the facilities of the home automation service. The conditional independence of the modelling graph is utilised to classify the significance of the context features. Several of the applications are technologically advanced in terms of programming languages; moreover, their software has specific codes, which it is essential to use in order for the program to run correctly.

#### Algorithm 2- for Naïve Bayesian decision making

\*\*\*\*\*

**Start** the timer to calculate the **Program Execution**

    Make a Database Connection

## Statistic-based Rule Computation for Context-Aware Automated Service

Read the data from Database and Save into context-aware database history

Close the Database Connection

**Input of the statistic rule:** the highest probability of the context-attributes invoked from TF-ICF-CF

**Output:** Find the maximum Naïve Bayesian rule then make decision.

**Step 1.** Calculation starts

Count total **Window ON**

Count total **Window OFF**

Count total **Fan ON**

Count total **Fan OFF**

Calculate Probability of Action for **Window ON**: by Calculate Probability total Lights ON then

Divide it with total (total Window ON+ total Window OFF+ total Fan ON + total Fan OFF)

Repeat like that for

    Calculate Probability of Action for Window OFF

    Calculate Probability of Action for Fan ON

    Calculate Probability of Action for Fan OFF

**Step 2.** Calculate Probability of each attribute (Sound, Light, Human body, Obstacle avoidance, Humidity, Smoke, Temperature, Distance and Location)

Count number of Temperature High = Model.Testo1List.Count (x => x. Tmp='Ht' ");

Count total of Sound = Model.Testo1List.Count(x =>! x. Sud.IsNullOrEmpty ())

Probability ["Tmp "] = Count number of **Temperature High** Divide by **Count Total of**

**Temperature;**

Repeat the same step for each value

**Step 3.** Calculate **Probability of Conditions** to Generate Conditional Probability Table (CPT)

Count number of **Temperature High** with device **Fan ON** = Model.Testo1List.Count(x => x.

Tmp == "Ht" && x. Device == "FO");

Count number of Devices Terms= Model.Testo1List.Count(x =>! x.Device.IsNullOrEmpty ());

Calculate **Probability of Conditions** = {{"TmpA", Count Number of **Temperature High** with device Fan **ON** / Count Number of **Devices Terms**}};

**Repeat** the same step between each **Term** value and the **Device Actions**

**Step 4.** Calculate **Conditional Independence Probability** for FO| (Lu, Ml, Hb, Ho, Hh, Ls, Ht, Cd, LR)



## Statistic-based Rule Computation for Context-Aware Automated Service

Resulttable ['ACTFO'] = Using Naïve Bayesian Algorithm

Note: this must be repeated as above until resulttable ["ACTLO"]

**Step 5.** Use for **Decision Making** to perform the action according to the **Maximum Equation**

**Step 6.** Calculation Ends

\*\*\*\*\*

### 5.3 Summary

This chapter has proposed that the methods that have typically been used for context-aware service approaches consist of four sections. The first section has provided the method for context-aware abstraction using a threshold-based method. In the second section, various context-aware information incorporation frameworks, as well as context-aware reasoning from physical layer to decision layer, have been proposed to link together raw sensing information and high-layer information appropriate to the model. In the third section, a context-aware computing service for decision-making using statistics-based methods has been investigated. The methods work with two techniques, which are derivation of context-aware items' weight using EF-ICF-IF, and derivation of a Naïve Bayesian context-aware home automation algorithm utilising context history. Finally, the evaluation frameworks for the structure of Pseudocode algorithms for both methods of application have been presented. In Chapter 6, the suggested methods are implemented and the performance results illustrated according to the scenarios of the case studies.

## **Chapter 6 The Smart Home Scenario and Statistical-Based Rules Performance**

Chapters 3, 4 and 5 have discussed the technologies, general system architecture and models for the implementation, design and algorithms of this research methodology, which include the context-aware computing service and logical decision-making. This chapter shows the results from three main perspectives. Firstly, it considers the outcome of the search engine using EF-ICF-IF to cross-check the attribute weight of each context item. Then it assesses the results of the use of Naïve Bayes decision making to determine the probability of all attributes, and finally evaluates the conditional independence between class ‘action’ and the items in the calculation of maximum likelihood. Through the Weka tool, the results of both k-fold cross-validation and ‘holdout’ 66% are compared in measuring the accuracy of classification (decision-making) derived from utilising Naïve Bayesian algorithms to train the database history. The studies described below consist of practical work using Window and Fan, as well as theoretical work which utilises the Weka tool to analyse the performance of class action accuracy in section 6.5.3, and the Receiver Operating Characteristic (McCarthy et al., 2006) curve area as shown in section 6.5.4.

### **6.1 Smart Home Case Study**

In previous studies, many scenarios have been implemented to create smart environments in the contexts of offices and healthcare, as well as from a smart home applications perspective (Sang-Hak Lee & Chung, 2004; Meng & Lu, 2015). In the latter case, it is necessary to analyse both the household technologies and the daily activities of residents in order to plan how the model will operate. The following scenario has been considered in order to address the design of a context-aware automated service in the smart home for older or disabled people who live alone.

Gill is a retired lady of 76 years who lives in a fairly modern and convenient house with many steps. Her mobility is affected by arthritis and she is also short sighted. She gets up late, at about 11 am, has a cooked breakfast, then does various household tasks or sometimes goes out for shopping or pleasure. She cooks tea at about 5 or 6 o’clock, usually spends the

## The Smart Home Scenario and Statistical-Based Rules Performance

evening at home and goes to bed at about 11 pm. The living room and bedroom each have one electric heater, a radiator from the gas-fired central heating system and a fan. The house has a TV, computer, two LED lights and also eight sensors to monitor the environment and activities within it. When the time reaches 11:00 am, Gill normally plans to enter the living room, and the home services are turned on when she reaches there. The owner's smart phone controls all the devices. Gill makes use of it in winter to control heating, and occasionally to control humidity all the year round. The obstacle-location sensor is often helpful, as Gill's mobility and agility are reduced by arthritis, and a fall could be dangerous. Turning lights and sockets on and off is easy at the present time and would be her preference, but remote-controlled switching may be useful if her disability were to begin to affect her neck and arms. Remote control of devices is also useful if she is in the garden, which is quite big.

As mentioned in the scenario above, the aim is to achieve automated switching ON/OFF of household technology. Implementing some relatively simple actions can achieve this. For example, if the living room is dark, an actuator will switch on the light to bring the brightness level to between 0 and 200 lux, and the fan will automatically turn off when there is nobody in the kitchen. Furthermore, after Gillian has gone to bed at 11 pm, the bedroom light must be switched OFF. The physical layer and higher layer should be compatible and initialised to recognize each other in advance. The utilities services, for example radio and video control, electrical home devices control and smart phone service need to be organised as a workstation computing service. The statistics-based rules and decision making are based on observation of the home environment, the resident's daily life activities and his/her preferences. In this way, data is collected.

### **6.2 Result of Using EF-ICF-IF in New Term-Weighting Context**

The purpose of EF-ICF-IF is to determine the new item weight model which may be best suited for smart home automation in a context-aware computing service. The problem is whether the total weight of each context item can be ranked according to the frequency of the item. A set of EF-ICF-IF statistics-based rules has been used in this research to measure the term weight from the context-aware database history as shown in section 5.2.1. This information is gathered from eight types of sensors in the lower level of the prototype

## The Smart Home Scenario and Statistical-Based Rules Performance

system, namely, obstacle avoidance sensors, ultrasonic distance measurement sensors, brightness sensors, sound sensors, smoke sensors, human body sensors, humidity sensors and temperature sensors. Therefore, the search engine is used to retrieve the information from the database, which will be deployed at the high level and work with the probability model using the Naïve Bayesian decision-making method.

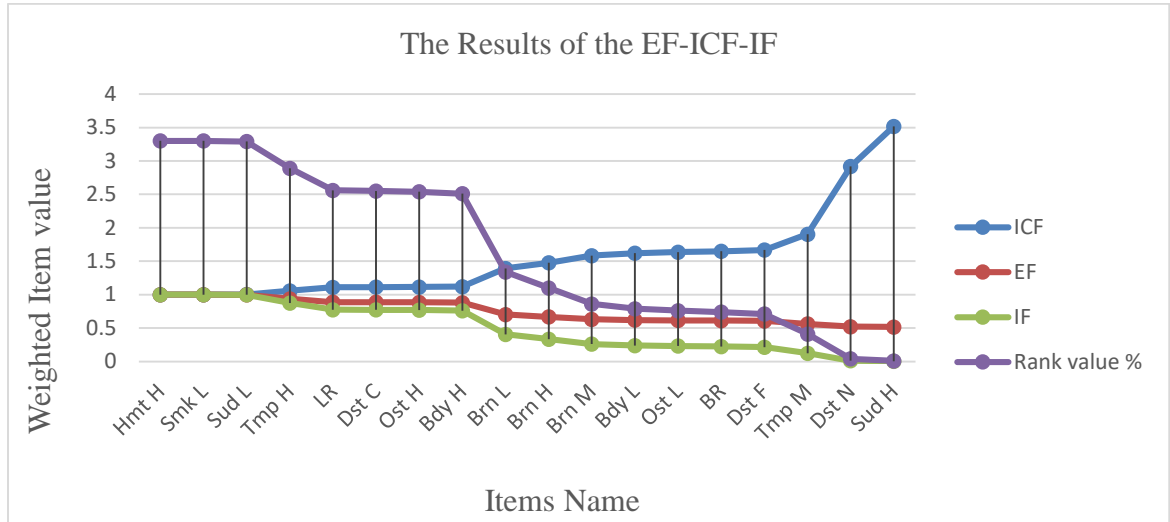

Figure 6-1 Results of computation using EF-ICF-IF method

Figure 6-1 shows the computation using the EF-ICF-IF method for each item that appears in the context database history. For instance, the total weight of each item can be calculated according to the results of context frequency on each page, inverse context frequency on all pages and context item frequency on all pages. This result has been investigated from eleven pages of database history; these include 330 rows of data gathered from eight sensors, as seen in Index B. The graph illustrates that the model results using the EF-ICF-IF technique are used to rank the context attributes that top the weight table by retrieving the relevant information and disregarding items of less weight. Through this rule, the relationship between the high-ranked items and other contexts is such that when the scale of the item is high, as in humidity high, smoke low and sound low, the ICF has the lowest value '1'. However, the outcome of both EF and IF has the highest value for the same attributes, as indicated in this graph, where the ranking value falls below the overall weighted context attributes, from 3.3% to 0.01%. The context frequency and context item frequency decrease according to each item's frequency from 1 to 0.003 for IF and from 1 to 0.01 for EF.

## The Smart Home Scenario and Statistical-Based Rules Performance

However, the inverse context frequency of weighted item values increases from 1 to 3.519. This works according to the function of the rule that when the ranking value decreases, the ICF increases. The best ranking performance from the algorithm, which has ranking values between 3.3 and 1.34, is given by the highest weight of each context item.

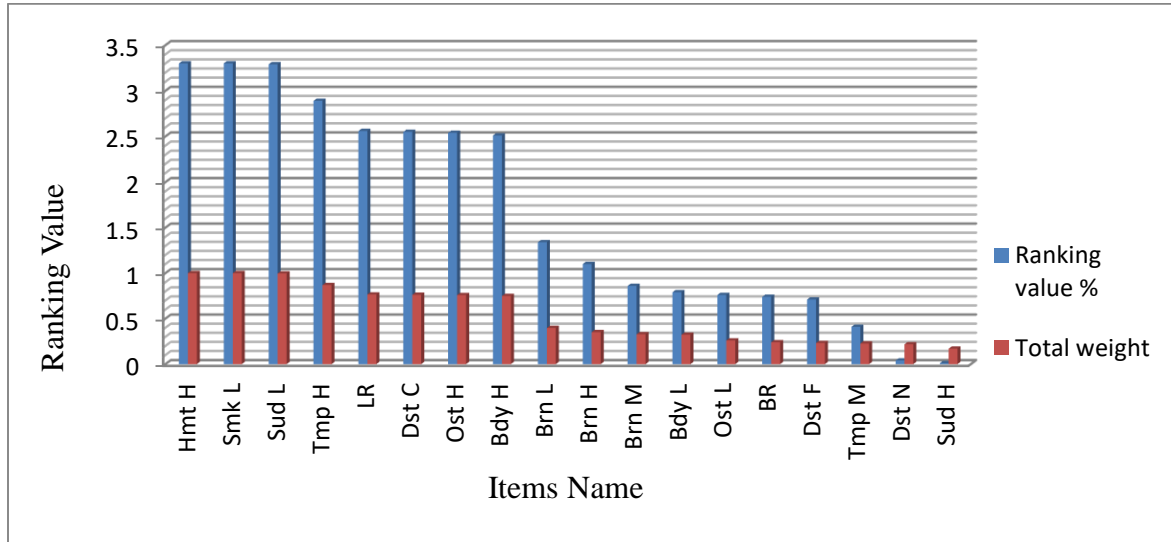

Figure 6-2 Relationship between total weights and ranking value

Figure 6-2 shows another investigation, which demonstrates the relationship between the total weights of context attributes and the ranking value according to the frequency of each item, which is here seen to be a positive correlation. The overall ranking of relevant attributes is retrieved from 18 out of a total of 27 items. When the ranking value of the items has a higher frequency, the total weight is also higher. As the ranking value decreases, from 3.30 to 0.01, then the total weight also decreases, from 1 to 0.17, as shown above. The relationship between IF and the ranking values for class actions can be found in Appendix C, Table Ac-1.

### 6.2.1 Results of Using Statistics-Based Rules with Context Data

The outcomes of using EF-ICF-IF and Naïve Bayesian algorithms to provide the weight of terms from the context-aware database history, the data having been taken from temperature, humidity, brightness, sound, smoke and distance measurement sensors. The weighted terms achieved via the EF-ICF-IF and Naïve Bayesian methods illustrate nearly identical results in both bar chart and line charts, both of which are considered statistical models.

## The Smart Home Scenario and Statistical-Based Rules Performance

EF-ICF-IF is used as a cross-check comparison to substantiate the results of the Naïve Bayes probability decision for the smart home automation system. The findings for the weighted terms from all algorithms, with an increasing number of frequency terms over the whole database history, also give the same results with regard to maximum weighted values, such as humidity high, smoke low and sound low. There is little significant variation between EF-ICF-IF and Naïve Bayesian decision making in the values of the weighted terms' probability across a small number of term frequencies, such as temperature medium, distance near and sound high. In addition, the graph illustrates that when the frequency of terms has the maximum value, the weighted probability is '1', and when the frequency decreases to '0', the weighted value is '0' in both methods. It can therefore be seen that using a search engine (EF-ICF-IF) and machine learning (Naïve Bayes network) as a hybrid system in the methodology of statistical-based rules is very satisfactory.

The values presented in Appendix C, Table Ac-1, illustrate the outcomes of computing the weighted values of context-aware attributes using the statistics-based rule  $W_{ij} = EF * ICF * IF$  and Naïve Bayes decision making applied to the database history of the smart home environment (see appendix B). Hence, the context-aware attributes are ranked according to the relevance, weight and frequency of each context item. Figure 6-3 shows the performance of both methods with an increased frequency number for each context-aware item and a corresponding increase in weight. There is no difference in context weight between Naïve Bayes and EF-ICF-IF when the frequency number is 330. The weight value is the same, and equal to '1', for humidity high, smoke low and sound low. In addition, when the frequency number is '0', the term weight is '0' for temperature very high and low, brightness high, humidity low and smoke low. However, there is a slight difference in weight values between the two methods when the frequency number starts to decrease from 289 to 41, when the weight attributes are between 0.86867769 and 0.13309486 for the search engine method, and for Naïve Bayes are between 0.8757576 and 0.1242424. Therefore, this investigation shows that the weights for the context-aware computing service using Naïve Bayes and EF-ICF-IF are the same when the frequency number is very high or zero, but are only slightly similar when the frequency numbers start to reduce from 289 to 1 (see Table Ac-1 Appendix C).

## The Smart Home Scenario and Statistical-Based Rules Performance

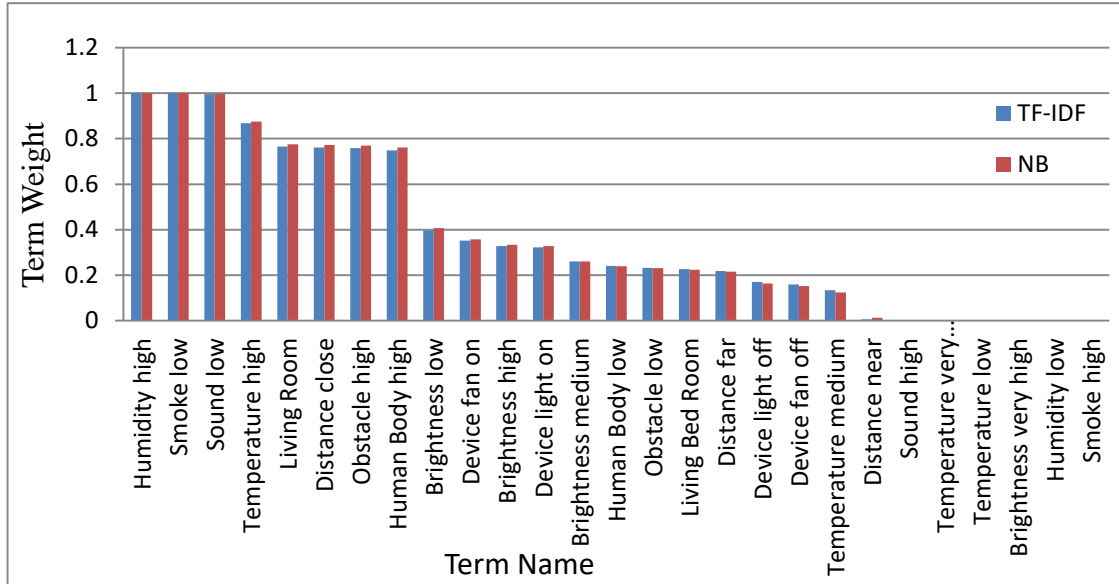

Figure 6-3 Results of weighting context-aware terms using statistics-based rules

### 6.3 Naïve Bayes Decision Making Results

The Naïve Bayes algorithm, which is typically expected to work efficiently, is regularly utilised in practice because of its simplicity and the small amount of classification of terms required. In general, this system is utilised for classification-based decisions. Depending on the attributes of the class variables intended for a certain occurrence, the class of that occurrence is the one most likely to exist. In addition, it is necessary to calculate the evidence to make an appropriate decision between class decisions  $A_1$  and  $A_2$  within the range of the model. Both needs can be addressed by the following relationship.

#### 6.3.1 Probability of each attribute

Actions and attributes are recorded in the database of the computer system. According to Equation 5-25, it is very important to find the probability value of each item of activity (action) and attribute (evidence) on the right side of the equation  $P(A=a_i)$ . This gives the decision-making action probability, while  $P(C_n | A_a)$  is the conditional independence of evidence  $C_n$  from class (action)  $A$  given an action  $a_i$ . As a first step, it is necessary to calculate the action probability of each item  $P(\text{Action})$  for all actions relating to devices,

## The Smart Home Scenario and Statistical-Based Rules Performance

such as window ON (WO), window OFF (WF), fan ON (FO) and fan OFF (FF). The records and the probability of these four actions are as shown in Figure 6-4.

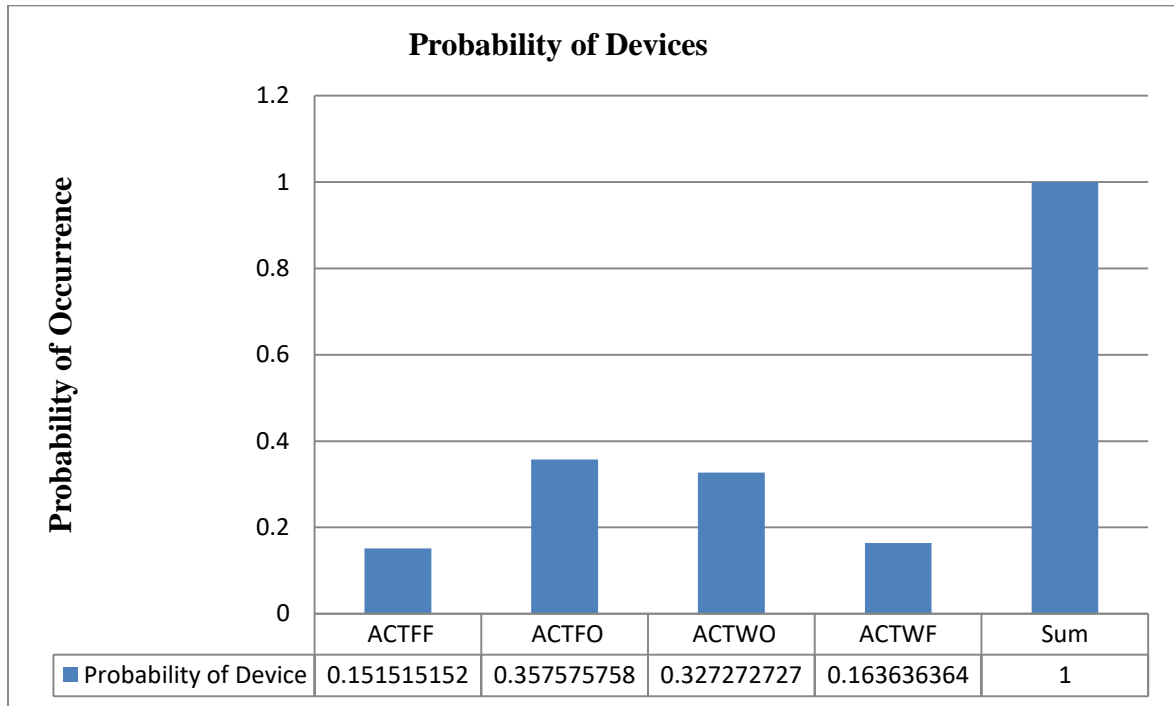

Figure 6-4 Action probability for window and fan

Next, all the probability evidence must be computed to find the highest weight for each item  $P(C_n = k_i)$ . For example, the light sensor, which has the results  $Ll = 0.74242424242424$ ,  $Ml = 0.23636363636364$  and  $Hl = 0.018181818181818$ , can record the probability values for three items. The same probability calculation can be made for the other attributes, including the temperature, humidity, sound, ultrasound distance measurement, human body, obstacle avoidance and location sensors.

### 6.3.2 Conditionally independent probability

The second step is to calculate the conditionally independent probability using this equation:

$$P(A = a_i | C_1 = c_{1i}, C_2 = c_{2i} \dots C_n = c_{ni}) = P(C_1 = c_{1i} | A = a_i), P(C_2 = c_{2i} | A = a_i) \dots P(C_n = c_{ni} | A = a_i) \quad 6-1$$

In this step it is necessary to find  $P(c_{1i} | a_i)$  for each  $a_i$ , and for each  $C_{1i}$  that has the highest probability in each attribute, where the sum of all the items of each attribute  $P(C_1=c_{1i} | A=a_i)$



## The Smart Home Scenario and Statistical-Based Rules Performance

= 1. For example, the conditionally independent probability of the temperature sensor value (Ht) must be found in relation to the four action probabilities WO, WF, FO and FF, using the attribute results for all records to find the conditional independence as performed below. Similarly, the calculation of step two must be repeated for each attribute of each item to find which has the highest probability, using the probability values of the four actions to compute the rest of the conditionally independent probability, as illustrated in Figure 6-5. In this figure it is clear that the fan ON has the highest conditionally independent probability results in contrast with the other actions fan OFF, window ON and window OFF.

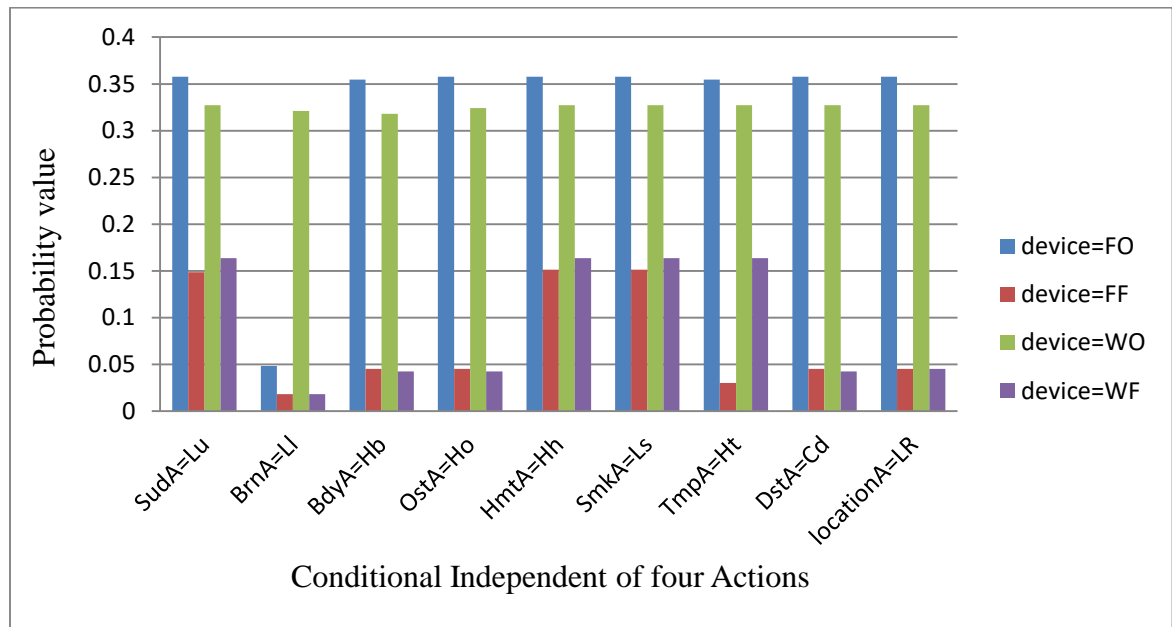

Figure 6-5 Results of conditionally independent probability for four actions

### 6.3.3 Maximum Likelihood

The last step is computing the Naïve Bayes maximum likelihood decision rule for each action to achieve the appropriate decision in the smart home automation. The Naïve Bayesian model associated with a decision-making rule is identified as the Maximum ‘a Posteriori’, or MAP, decision-making model. This is done by substituting steps one and two in Equations 5-28 and 5-29 to calculate the specific probability rule-based decision for each item of context-aware data in the database history. This will enable the test experiments to observe which decision action has the greatest probability of executing and controlling the

## The Smart Home Scenario and Statistical-Based Rules Performance

smart home environment successfully. Decision rules are generated for each activity relating to electrical devices (window and fan) in order to create the actions. For example, the Naïve Bayes decision rule is based on the first results of conditionally independent prior evidence of ‘fan ON’ values.

In Appendix B Table Ab-1, the highest probability of conditions and attributes in the smart home environment, as well as the human body, have been detected by different kinds of sensors such as the human body sensor, the obstacle avoidance sensor and the ultrasonic distance measurement sensor. These obey the rule of C= (probability [Bdy], probability [Ost], probability [Hmt], probability [Tmp], probability [Dst] and probability [location]), and the decision actions are A= [window ON], [window OFF], [fan ON], [fan OFF]. The home appliances are controlled according to the results of the highest probability between the rules. For example, in a situation where Bdy=High, Ost=High, Hmt=High, Tmp=High, Dst=Closed, Location=Living Room, the rules used to calculate the Maximum a Posteriori in order to execute the decision-making action can be formulated as shown below:

$$P [FO|C_n] = \frac{(P(FO)*P(Bdy|FO)*P(Ost|FO)*P(Hmt|FO)*P(Tmp|FO)*P(Dst|FO)*P(Locat|FO))}{P(Bdy)*P(Ost)*P(Hmt)*P(Tmp)*P(Dst)*P(Locat)} \quad 6-2$$

$$\begin{aligned} \text{Resulttable}[FO] &= \frac{0.35758 (0.35455 * 0.35758 * 0.35758 * 0.35455 * 0.35758 * 0.35758)}{0.40606 * 0.76060 * 0.76969 * 1 * 0.87576 * 0.77273 * 0.77576} \\ &= 0.0023909387663368 \end{aligned}$$

$$\begin{aligned} \text{Resulttable}[FF] &= \frac{0.15151(0.04545 * 0.04545 * 0.15151 * 0.03030 * 0.04545 * 0.04545)}{0.40606 * 0.76060 * 0.76969 * 1 * 0.87576 * 0.77273 * 0.77576} \\ &= 9.6625496505964E - 9 \end{aligned}$$

$$\begin{aligned} \text{Resulttable}[WO] &= \frac{0.32727(0.31818 * 0.32424 * 0.32727 * 0.32727 * 0.32727 * 0.32727)}{0.40606 * 0.76060 * 0.76969 * 1 * 0.87576 * 0.77273 * 0.77576} \\ &= 0.0012603133826165 \end{aligned}$$

$$\begin{aligned} \text{Resulttable}[WF] &= \frac{0.16364(0.04242 * 0.04242 * 0.16364 * 0.16364 * 0.04242 * 0.04545)}{0.40606 * 0.76060 * 0.76969 * 1 * 0.87576 * 0.77273 * 0.77576} \\ &= 4.9481554994845E - 8 \end{aligned}$$

## The Smart Home Scenario and Statistical-Based Rules Performance

Figure 6.6 illustrates the maximum likelihood results of the Naïve Bayes decision-making algorithm using Equation 5-28 when the temperature is high, and the human body performance produces the final set of rules in the undertaking of fan and window control. As a result, the rule is considered to obtain consistency when using four devices based on maximum likelihood in a practical situation with four comparative methods: window ON, window OFF, fan ON and fan OFF. The statistical algorithm for action FO confirms that the maximum likelihood of fan ON has the highest probability when the temperature and the humidity are high, with about  $2.39 \text{ E-}3$  and a rate of 65%. This is compared with the same device action fan OFF, which has the maximum likelihood of  $9.66\text{E-}9$  with a rate of  $2.646\text{E-}6\%$  approximately '0' percentage.

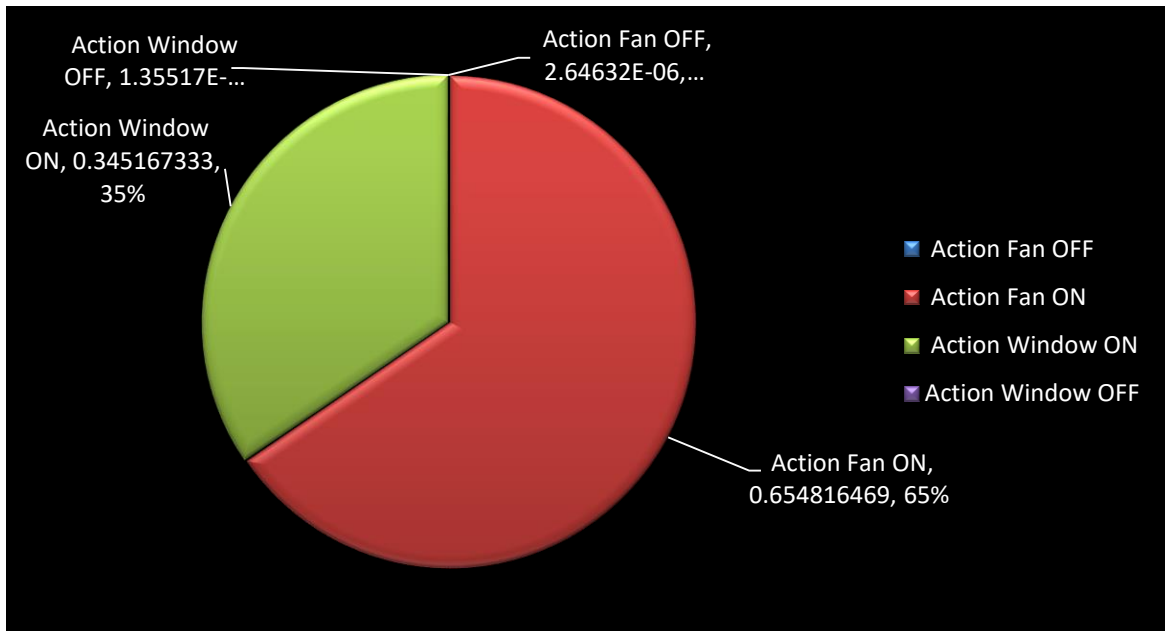

Figure 6-6 Maximum likelihood of executing the decision-making action (PHP)

The statistical algorithm for class action WO confirms that the maximum likelihood of window ON has the probability value when the temperature and the humidity are high, with about  $1.26 \text{ E-}3$  and a rate of 35%. This is compared with the same device action window OFF, which has the maximum likelihood of  $4.95\text{E-}8$  with a rate of  $1.355\text{E-}5\%$  approximately '0' percentage. The maximum likelihood of a light open and light close appliance, but because of the absence of the context-aware values of brightness sensor and

## The Smart Home Scenario and Statistical-Based Rules Performance

sound sensor results in this rule, the posterior probability of light ON and OFF is not important in this rule except as class actions. Figure 6.6 and 6.7 shows the maximum a probability calculated by Equation 5-26 in section 5.2.3. This formula is used to compute the likelihood that a decision will make from the same data history and normalising the results between ( $0 \leq \text{MAP} \leq 1$ ) to generate the maximum a probability rule to control the home facilities. In order to show which action decision has the highest probability using rules generated from the context-aware data. This algorithm function must have probability results for each rule between 0 and 1, and the total sum of the four rules must be 1. This illustrates how the fundamental algorithm of the Naïve Bayes decision-making rule may be used to calculate the maximum likelihood in order to decide on an appropriate action.

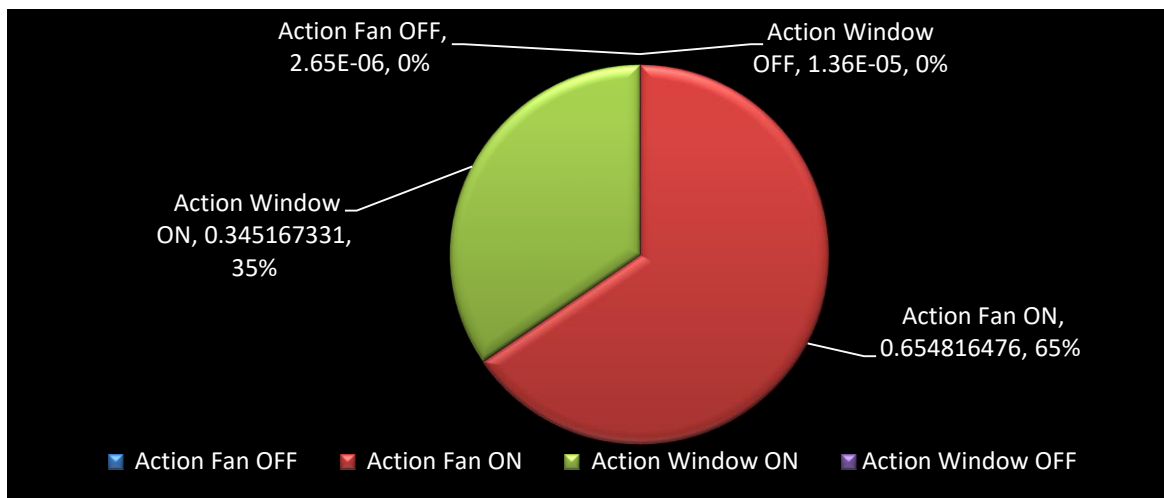

Figure 6-7 Maximum likelihood of executing the decision-making action (.NET)

### 6.4 Weka Confusion Matrix (Error Matrix) Results

This section concentrates on performance evaluation of the use of context-aware database history in smart home automation. This evaluation is based on the Weka tool. In the field of machine learning, and particularly in relation to probability-based rules, the supervised decision system has four options which are employed in the confusion matrix to allow the algorithm to visualise their performance, as illustrated in Table 6.1. The Naïve Bayes classifier has previously been widely utilised in different areas of smart home application problems, as well as in decision making (Babakura et al., 2014). In addition, three different

### The Smart Home Scenario and Statistical-Based Rules Performance

classifier methods have been tested using the Weka tool to compare them as decision-making methods; for example, the Support Vector Machine and K-Nearest Neighbour algorithms have been compared with the Naïve Bayesian model. These methods have all been extensively used in smart home problems, especially for regulating the activities of daily life (Bourobou & Yoo, 2015), but the Naïve Bayesian model has illustrated the most promising results in context-aware automated services, particularly from a practical perspective (B. Das et al., 2012). For that reason, it was chosen as the training method in this study.

Table 6-1 Confusion matrix

		Predicted Condition	
		Classified as Positive	Classified as Negative
Actual Condition	Condition Positive	$TP = \frac{\sum \text{True positive}}{\sum \text{Condition positive}}$	$FP = \frac{\sum \text{False positive}}{\sum \text{Condition negative}}$
	Condition Negative	$FN = \frac{\sum \text{False negative}}{\sum \text{Condition positive}}$	$TN = \frac{\sum \text{True negative}}{\sum \text{Condition negative}}$

The True Positive (TP) rate is calculated as ‘sensitivity’; that is, the number of positive cases of actions that were properly classified as positive actions. The False Negative (FN) rate is the number of positive cases that were wrongly classified as negative actions. False Positive (FP) is the number of negative cases that were wrongly classified as positive actions, and the True Negative (TN) rate is calculated as ‘specificity’; that is, the number of cases of negative actions that were properly classified as negative. A number of evaluation metrics can result from the confusion matrix: Where the calculation of the total number of test models of any decision action class is the sum of the corresponding row, it means that  $TP+FN$  for that class needs to be measured.

## The Smart Home Scenario and Statistical-Based Rules Performance

1. The calculation of the total number of FNs for a decision action class is the sum of values in the corresponding row (excluding TP).
2. The total number of FPs for a decision action class is the sum of values in the corresponding column (except TP).
3. The total number of TNs for a certain decision action class will be the sum of all columns and rows excluding that class's column and row.
4. Precision (P) is the rate function of correctly retrieved context-aware decision instances that are relative to all instances classified as decision making, and is considered as a positive predictive value in Equation 6-3:

$$Precision = \frac{TP}{TP+FP} \quad 6-3$$

5. Recall (R) is the rate function equivalent to TPR (sensitivity) and is calculated as in formula 6-4:

$$TPR = \frac{TP}{TP+FN} \quad 6-4$$

6. The F-measure (F-score) is the harmonic mean for both precision and recall, and can be used as a weighted value. The F-measure is derived from both the FP and FN rate values, and is computed as in Equation 6-5. In this evaluation of the weights matrix, both R and P are important, and good decision-making will maximise both P and R instantaneously. Therefore, reasonable performance will be rated with the best score as '1' and the worst performance as '0'.

$$F1 = \frac{2 \textit{Precision} * \textit{Recall}}{\textit{Precision} + \textit{Recall}} \quad 6-5$$

7. Accuracy (ACC) is the total rate of correct instances of decision-making actions in relation to the total number of occurrences in the context-aware database history. It is assessed as shown in Equation 6-6:

$$Acc = \frac{TP+TN}{TP+FP+TN+FN} \quad 6-6$$

8. Specificity (SPC) corresponds to the true negative rate of the considered class action decision, where the total number of calculations of true negative and false positives for the considered action class can be calculated as in Equation 6-7.

## The Smart Home Scenario and Statistical-Based Rules Performance

$$SPC = \frac{TN}{TN+FP} \quad 6-7$$

where TN is the total number for a certain class action decision. It is the sum of all columns and rows excluding that class action decision from the column or row, as shown in Table 6.2 and Equation 6.8.

$$TN_{WO} = TP_{FO} + E_{FO/WF} + E_{FO/FF} + E_{WF/FO} + TP_{WF} + E_{WF/FF} + E_{FF/FO} + E_{FF/WF} + TP_{FF} \quad 6-8$$

Table 6-2 Calculation of  $TN_{WO}$

Predicted Condition					
		FO	WF	FF	WO
Actual Condition	FO	$TP_{FO}$	$E_{FO WF}$	$E_{FO FF}$	$E_{FO WO}$
	WF	$E_{WF FO}$	$TP_{WF}$	$E_{WF FF}$	$E_{WF WO}$
	FF	$E_{FF FO}$	$E_{FF WF}$	$TP_{FF}$	$E_{FF WO}$
	WO	$E_{WO FO}$	$E_{WO WF}$	$E_{WO FF}$	$TP_{WO}$

### 6.5 Training set for creating the prediction models

One of the main targets of this section is to investigate how the rules for conditions can be defined so that these rules can be compared against the model's predicted conditions when the database is updated; this will enable the accuracy of each class action to be determined. An error, or confusion, matrix is utilised with decision-making systems for class actions, since the response results are explicit. For every observation condition rule, the system predicts one of the reaction results in the classifier training set. In addition, for each observation, the predicted condition response is compared to the model's actual condition response for that observation. Subsequently, an error matrix evaluates the accuracy of class actions constructed by the predictive system.

Due to the difficulty of the physical smart home environment, the actual condition rules for evaluating the database history of this model are very complex. Additionally, the process

## The Smart Home Scenario and Statistical-Based Rules Performance

involves some other techniques that make the system more complex during testing and evaluation of the model's training data.

The database history of user attributes including the human body sensor, obstacle avoidance sensor, temperature sensor, humidity sensor, location and approved service devices. The fan, light and window were chosen as cases for the examination of context-aware home automation in this study. Four class actions were considered, namely, fan ON (FO), fan OFF (FF), window ON (WO) and window OFF (WF), where the class action was the decision attribute and others were conditional attributes. At this stage, the model was implemented using functions from the training database history to control the smart home devices.

The concepts used here, which are concerned with the conditional rules for smart home automation, can be used as actual conditions for context-aware automated control of the real-world environment. The machine learning uses a supervised Naive Bayesian approach, which can be described as data generation based on database history. The model has been built according to the database given to the algorithm, which is called training data. It can be used to estimate the accuracy of the class action when the system determines the differences between predicted conditions and the actual conditions of the target attributes of the testing model.

### 6.5.1 The condition system to test the trained models

Utilising a method based on classification, IF- ELSE rules can be used to classify the actual conditions and impact of defective attributes. This logic method is based on the presence of a human body, and the impact on this body using IF- ELSE is expressed in the formulae specified below: Table 6-3 defines the rules for actual conditions in the case study environment, determined according to the smart home scenario where elderly people can live independently.



## The Smart Home Scenario and Statistical-Based Rules Performance

Table 6-3 Rules (Actual Conditions and Decisions Attributes)

Rule	Rules (Actual Conditions and Decisions Attributes)	Explanation of the condition
S1=	$(C_{Human} \text{ is Low}) \wedge (C_{Ost} \text{ is Low}) \wedge (C_{Hmt} \text{ is High}) \wedge (C_{Tmp} \text{ is Medium}) \wedge (C_{Dst} \text{ is Far}) \wedge (C_{Location} \text{ is Bedroom}) \Rightarrow \text{Fan OFF}$	Nobody in the sensing area of the bedroom location, therefore the device action is to switch OFF the Fan.
S2=	$(C_{Human} \text{ is High}) \wedge (C_{Ost} \text{ is High}) \wedge (C_{Hmt} \text{ is High}) \wedge (C_{Tmp} \text{ is High or } C_{Tmp} \text{ is Very High}) \wedge (C_{Dst} \text{ is Close}) \wedge (C_{Location} \text{ is Living room}) \Rightarrow \text{Fan is ON}$	A human body has been detected by sensors and the temperature and humidity are high, therefore the action is to switch ON the Fan.
S3=	$(C_{Human} \text{ is Low}) \wedge (C_{Ost} \text{ is Low}) \wedge (C_{Hmt} \text{ is High}) \wedge (C_{Tmp} \text{ is High or } C_{Tmp} \text{ is Very High}) \wedge (C_{Dst} \text{ is Far}) \wedge (C_{Location} \text{ is Bedroom}) \Rightarrow \text{Window is OFF}$	No human body has been detected by sensors, and the temperature and humidity are high and very high, but the location is bedroom so the action is Windows OFF.
S4=	$(C_{Human} \text{ is High}) \wedge (C_{Ost} \text{ is High}) \wedge (C_{Hmt} \text{ is High}) \wedge (C_{Tmp} \text{ is High or } C_{Tmp} \text{ is Very High}) \wedge (C_{Dst} \text{ is Close}) \wedge (C_{Location} \text{ is Living room}) \Rightarrow \text{Window is ON}$	Somebody has been detected by sensors, the temperature and humidity are high and very high, and the location is the living room; therefore, execution of device is Window ON.
S5=	$(C_{Human} \text{ is Low}) \wedge (C_{Ost} \text{ is Low}) \wedge (C_{Hmt} \text{ is Low}) \wedge (C_{Tmp} \text{ is Low or } C_{Tmp} \text{ is Medium}) \wedge (C_{Dst} \text{ is Far}) \wedge (C_{Location} \text{ is Bedroom}) \Rightarrow \text{Fan OFF}$	When no human has been detected by any sensor, the temperature is low or medium and humidity is low, and the location is the bedroom, then the fan device is switched OFF.
S7=	$(C_{Human} \text{ is Low}) \wedge (C_{Ost} \text{ is Low}) \wedge (C_{Hmt} \text{ is High}) \wedge (C_{Tmp} \text{ is Low or } C_{Tmp} \text{ is Medium}) \wedge (C_{Dst} \text{ is Far}) \wedge (C_{Location} \text{ is Bedroom}) \Rightarrow \text{Window is OFF}$	No human body has been detected in the location of the bedroom, the humidity is low and the temperature is low or medium, so the window appliance is switched OFF.
S8=	$(C_{Human} \text{ is High}) \wedge (C_{Ost} \text{ is High}) \wedge (C_{Hmt} \text{ is Low}) \wedge (C_{Tmp} \text{ is Low or } C_{Tmp} \text{ is Medium}) \wedge (C_{Dst} \text{ is Close}) \wedge (C_{Location} \text{ is Living room}) \Rightarrow \text{Window is ON}$	If a human body has been sensed in the area of the living room, with high humidity and medium temperature, then the windows should be switched ON

The presence of an inhabitant can be detected by the function of sensors such as the human body sensor ( $C_{Human}$ ), obstacle avoidance sensor ( $C_{Ost}$ ) and ultrasonic distance measurement sensor ( $C_{Dst}$ ). Thus, if  $C_{Human}$  is High,  $C_{Ost}$  is High and  $C_{Dst}$  is Close, and the temperature is high or very high ( $C_{Tmp}$  is High or  $C_{Tmp}$  is Very High), the fan is turned

## The Smart Home Scenario and Statistical-Based Rules Performance

on automatically. This situation would provide the actual condition attributes in the smart home system as:

$C = \{CHuman, CDistance, CObstacle, CTemperature, CBrightness, CHumidity, CLocation\}$ .

The actual condition decision attributes for smart home devices control,  $A = \{aLight, aFan, aWindow\}$ , are decided according to the total weight and data ranking of the context attributes. In order to establish how the decision making using the classification rules works in the smart home environment, a set of context-aware data from the model's database history was selected as the existing context of actual conditions:

$CV_i = \{High, Close, High, High\ or\ Very\ high, Low\ or\ Medium, Living\ Room\}$ .

The context rules ( $CV_i, Condition$ ) represent the actual condition between the context sample  $CV_i$  and the *Class Action* rule.

### 6.5.2 Rule Matching between actual condition and prediction condition

The target of this model is to determine the conditions of successful device control according to the situation of the data-gathering environment. The predicted sensor value and class action conditions from the database history are compared with the sensor value and class action conditions for an actual instance. The proposed method has been tested in the real-world environment of a smart home database and compared with existing methods.

An error matrix is a convenient method of evaluating a model if the response values are known as actual conditions. However, it is difficult to know which of the evaluations are True Positive, True Negative, False Positive or False Negative without a built model on which to test the actual condition results. The main goal of the confusion matrix is to determine the values of sensitivity, specificity, ROC curve, precision and accuracy of each class action.

Based on the scenario of the smart home environment, the training database history has been generated in the form of 330 samples of data from the sensors. Unless the model is created by a cross-validation programme, training data must be used to enable such a model to achieve the necessary level of accuracy. Then the system has been applied to the 10 samples

## The Smart Home Scenario and Statistical-Based Rules Performance

in the database history. Naive Bayes, supported by vector machine and k-NN, has been implemented within the Weka tool for the decision-making process of smart home automation. The database consists of 330 records with eight attributes, which have been utilised for classifying and analysing the smart home facilities database. The accuracy of the class actions should be compared with these algorithms; then, the number of attributes should be reduced according to the scenario of the smart home facilities.

The confusion matrix is utilised for presenting the number of true and false condition predictions made, compared with the actual conditions classified in the test database history. The error matrix is presented in an  $N \times N$  format, where  $N$  is the number of class actions for each approved physical service. Therefore, the accuracy of all classes can be computed from the confusion matrix. According to the actual system conditions, it is important to assess which of the home facilities is needed or not, and also whether it is necessary to implement control of the devices. In addition,

$C = \{CHuman, CDistance, CObstacle, CTemperature, CBrightness, CHumidity, CLocation\}$ .

The actual condition decision attributes for smart home devices control,

$A = \{aLight, aFan, aWindow\}$ , are decided according to the total weight and ranking of data among the context attributes.

From the actual condition rules, it is possible to evaluate which of the smart home facilities needs to be switched ON or OFF, and whether execution of this action is required. In addition, with the help of new, updated rules, it is possible to predict conditions and compare them with the actual conditions in order to determine the accuracy of the model. This will improve the ability of the model to decide the right action to execute. Then, an efficient and effective machine-learning algorithm is necessary for decision making in the smart home environment. The Naive Bayesian network is a convenient method in which only the class action is considered in the algorithm. The resultant formula can be expressed as  $C \rightarrow A$ , where  $A$  is the class action. It is essential to define the class action problem in a suggested model framework:

## The Smart Home Scenario and Statistical-Based Rules Performance

Let the training database history set  $C$  have  $i$  attributes  $C = [C_1, C_2, C_3, \dots, C_n]$  with  $n$  ( $n > 1$ ) items; let  $c_i = [c_{1i}, c_{2i}, c_{3i}, \dots, c_{ni}]$  be an observation of  $C$  and let  $A$  be a concept of the class action which is labelled by supervised machine learning, where  $A = [A_1, A_2, A_3]$ .

All concept values should be categorised as a finite set, which compares the actual context condition with the currently predicted condition to improve accuracy and provide a suitable context computing service.

**Step 1:** The current context row or training value in  $C$  can be labelled as a mixture of attribute  $C_i$  and values  $c_{ij}$ , as well as a class action defined by  $a_j$ .

**Step 2:** The context item can be defined as a feature named  $C_i$  and a value  $c_{ij}$ .

**Step 3:** The context item database set can be defined as a set of items included in a training database history.

**Step 4:** A condition rule  $S$  is in the formula of  $\langle \text{item set}, a \rangle$ , where  $a \in A$  is the class action.

**Step 5:** The actual condition detection (*actcond*) of a rule  $s$  in  $C$  is the number of rows in  $C$  that match the item set defined in  $s$ .

**Step 6:** A rule  $s$  is presented by a *total weight* threshold if  $(\text{totweig}(s)/\text{actcond}(s)) \geq \text{totweig}$ .

**Step 7:** An actual condition class collection rule is characterised by the method:  $(C_{11} \text{ or } C_{12}) \wedge \dots \wedge (C_{21} \text{ or } C_{22}) \rightarrow a_{11}$ , where the class action is of the formula  $S : C \rightarrow A$ , where  $C$  is a set of items and  $A$  is the class action. The main idea of the training data is to prepare a set of rules (system) that is capable of predicting the class actions of a previously unobserved database history, which is known as the test, as precisely as possible. Therefore, the objective is to observe a classifier  $s \in S$  that maximises a probability (MAP) that  $s(c) = a$ , for each of the test attributes  $(c, a)$ .

In order to utilise the Weka tool for prediction, context training data and test data would be required. Metrics from only one release were gathered, but used with both stratified holdout (split 66.0% train) and 10-fold cross validation methods. Once the model had been created, it would be possible to create the predicted conditions for a database history, whether the context data included valid class action values or not. The output results would include both the predicted and actual condition class actions for each instance. The columns in Table 6-4 show predicted and actual values where instances 13, 20, 46, 63, 76, 87 and 109 are

### The Smart Home Scenario and Statistical-Based Rules Performance

predicted to be of class action ‘FO’, with the value ‘WF’. In addition, instances 1, 62 and 92 are predicted to be a class action ‘WF’, whose value is ‘FF’. Therefore, error predictions were being achieved on a labelled context-aware database set for instances where the actual value of class action ‘WF’ was 0.615, and the error prediction for the class action ‘FF’ was 0.896. In Appendix D, Table Ad-13 shows the actual, prediction and error prediction results using holdout 66.0% train.

Table 6-4 Sample output for both actual and predicted class actions

Instance	Actual	Predicted	Error prediction
1	3:FF	2:WF	+ 0.893
13	2:WF	1:FO	+ 0.615
20	2:WF	1:FO	+ 0.615
46	2:WF	1:FO	+ 0.615
62	3:FF	1:FO	+ 0.615
63	2:WE	1:FO	+ 0.615
76	2:WF	1:FO	+ 0.615
87	2:WF	1:FO	+ 0.615
92	3:FF	2:WF	+ 0.893
109	2:WF	1:FO	+ 0.615

#### 6.5.3 Experimental Results of Naïve Bayes Decision Making using Weka Tool

This section aims to evaluate decision-making performance in various context-aware databases through two tests, 10-fold cross-validation and the holdout method’s percentage split, using Weka tool 3-8, as mentioned in section 2.10. Both methods’ results after assessment are described here. Since performance may differ depending on how the 10-folds are apportioned, this technique was repeated three times for each algorithm, in order to obtain a passable statistics-based rule for the decision-making model using six types of sensors to perform the class actions accurately. The results of the algorithms employed are scheduled in Table 6.3 for the performance of confusion metrics, classification accuracy and recall rate. It was found that the statistics-based rule showed a progressively improving performance in decision-making. This is because utilising the conditional independence on which Naïve Bayes is based seldom produces incorrect outcomes in practical physical applications.

## The Smart Home Scenario and Statistical-Based Rules Performance

### 6.5.3.1 10-fold cross-validation

There are a number of studies employing 10-fold cross validation to train Naïve Bayes decision making for the smart home environment, and for context-awareness using the smartphone (Babakura et al., 2014; Guinness, 2015; Wang et al., 2012; Q. Wu et al., 2005). One earlier work used 5-fold cross-validation to determine which sub-class action would be triggered by the device in intelligent home facilities (Shahi et al., 2015). In another study, (Kohavi, 1995) estimated the accuracy of the Naïve Bayesian classifier through the holdout method, where the data are split into two parts: 66% for training and 34% as a test set.

In this work, the prototype system used to control facilities for smart home automation in the example scenario of elderly people involves the use of four electrical devices, which are fan and window. Opening and closing the window and switching the fan on and off are actions dependent on the home environment's temperature and brightness. Focusing on a four action (class) problem with the class actions of window ON (WO), window OFF (WF), fan ON (FO) and fan OFF (FF), the confusion matrix as shown in Table 6.3 was followed as the model was run. The algorithm used in this experiment was the Naïve Bayesian classifier tool. This model could be run by different services such as local host Visual Studio or Remote Apache/MySQL/PHP. These codes are decided by the researcher or another editor can learn a database history utilising a learning model provided in the Weka tool.

In order to make an accurate decision, the relative accuracy percentage of each class was measured to give information on how the statistics-based rule is likely to perform when the electrical devices are involved in real-world context-aware situations. The experiment to evaluate the ability of Naïve Bayes decision making to select appropriate actions in smart home automation was performed using two methods. Both methods showed the accuracy of the decision making for all classes to be very high. Therefore, it was necessary to concentrate on the effectiveness of the practical performance of the Naïve Bayes network for the computing context-aware service.

## The Smart Home Scenario and Statistical-Based Rules Performance

Table 6-5 Confusion matrix in smart home decision making

Predicted Condition					
Actual Condition		FO	WF	FF	WO
	FO	TP <sub>FO</sub> =118	$E_{FO WF}=0$	$E_{FO FF}=0$	$E_{FO WO}=0$
	WF	$E_{WF FO}=14$	TP <sub>WF</sub> =40	$E_{WF FF}=0$	$E_{WF WO}=0$
	FF	$E_{FF FO}=5$	$E_{FF WF}=5$	TP <sub>FF</sub> =40	$E_{FF WO}=0$
	WO	$E_{WO FO}=0$	$E_{WO W}=1$	$E_{WO FF}=0$	TP <sub>WO</sub> =107

Using the above confusion matrix results, the accuracy of decision making for each action should be assessed by calculating the four options (True Positive, True Negative, False Positive and False Negative).

Table 6-6 Detailed accuracy by class using 10-fold

Class	TP Rate	FP Rate	Precision	Recall	F-Measure	MCC	ROC Area	PRC Area
<b>FO</b>	1.000	0.090	0.861	1.000	0.925	0.886	0.999	0.999
<b>WF</b>	0.741	0.022	0.870	0.741	0.800	0.768	0.977	0.779
<b>FF</b>	0.800	0.000	1.000	0.800	0.889	0.879	0.969	0.901
<b>WO</b>	0.991	0.000	1.000	0.991	0.995	0.993	0.999	0.999
<b>Weighted Average</b>	0.924	0.036	0.929	0.924	0.922	0.900	0.991	0.948

The above error matrix demonstrates the classes of decision-making utilising the Naïve Bayesian model based on database history. These have been evaluated through the Weka tool, where the attributes have been chosen randomly using 10-fold cross validation. To calculate the rate of each class it is necessary to compute the total number of TP, TN, FP and FN.

## The Smart Home Scenario and Statistical-Based Rules Performance

### 6.5.3.2 Holdout method using Naïve Bayes

The holdout method was also used to calculate the accuracy of Naïve Bayes decision making for each action in the smart home environment. This was done by following the same steps as those in the above method of 10-fold cross-validation. The confusion matrix below was generated for the same context-aware class actions, namely, window ON (WO), window OFF (WF), fan ON (FO) and fan OFF (FF).

Table 6-7 Detailed accuracy by class

<b>Class</b>	<b>TP Rate</b>	<b>FP Rate</b>	<b>Precision</b>	<b>Recall</b>	<b>F-Measure</b>	<b>MCC</b>	<b>ROC Area</b>	<b>PRC Area</b>
<b>FO</b>	1.000	0.107	0.822	1.000	0.902	0.857	1.000	1.000
<b>WF</b>	0.696	0.022	0.889	0.696	0.780	0.740	0.936	0.798
<b>FF</b>	0.833	0.000	1.000	0.833	0.909	0.899	0.980	0.917
<b>WO</b>	1.000	1.000	1.000	1.000	1.000	1.000	1.000	1.000
<b>Weighted Average</b>	0.911	0.040	0.918	0.911	0.908	0.883	0.984	0.945

This section presents the outcomes of the analysis of Naïve Bayes decision making in smart home automation, achieved using both 10-fold cross-validation and the holdout method with the Weka tool. The experimental results illustrated in this study concern the accuracy of decision-making classification of suitable actions regarding switching ON or OFF appliances according to weighted context-aware attributes gathered from a variety of sensors and class actions from actuator devices. Table 6-8 show a contrast between the results of using 10-fold and holdout methods to evaluate the performance of the proposed algorithms in terms of recall, precision, F-measure, True Positive rate and False Positive rate. The aim of the test and training was to evaluate the statistics-based rule system in the area of practical services in smart home automation. All the class actions had highly positive results, which means that the functionality of Naïve Bayes is very accurate and gives a high level of performance in making correct decisions about the use of smart home electrical appliances according to information retrieved from the home environment. The results of accuracy and specificity according to both 10-fold cross-validation and holdout methods are presented in Table 6-8.



## The Smart Home Scenario and Statistical-Based Rules Performance

Table 6-8 Evaluation of accuracy of Naïve Bayesian use of database history

Class Action	10-fold cross-validation		Holdout method	
	Accuracy (%)	Specificity (%)	Accuracy (%)	Specificity (%)
<b>FO</b>	94.2	91.0	92.9	89.3
<b>WF</b>	93.9	97.8	91.9	97.8
<b>FF</b>	97.9	100	97.3	100
<b>WO</b>	99.7	100	100	100
<b>Average</b>	96.425	97.2	95.525	96.775

Both procedures were used to train and test Naïve Bayesian decision making. Because performances may differ depending on how the folds are divided, this technique was repeated 10 times for k-fold, and with 66% percentage split for the holdout process, with the purpose of finding reliable statistics related to decision-making accuracy. Table 6-6 shows the accuracy for all class actions. The 10-fold cross-validation and holdout percentage split results are approximately similar and the accuracies of both methods are high. In the case of 10-fold cross-validation of decision making for class actions, both FF and WO perform very well at 97.9% and 99.7%. This is slightly higher than the accuracy of FO and WF using the same method. However, the accuracy results using the holdout method for the class actions WO and FF are a little higher than those for WF and FO, with 100% and 97.3%. It can also be observed that all decision classes show nearly the same accuracy for each action according to both methods. This is because there are correctly classified instances in 305 rows, which is 92.4242% of the total 330 rows. Moreover, the F-measure functions as a weighted value in relation to precision and recall in both methods (10-fold and holdout). Precision and recall have weighted averages of 92.9 % and 92.2% respectively, which are very acceptable results.

### 6.5.3.3 Visualisation of threshold ROC curve

The experiment was separated for this process into four different classes of activity, namely, window ON/OFF and fans ON/OFF. These activities were used as training data to predict the best context-aware decision service in the home automation field. All such actions in the

## The Smart Home Scenario and Statistical-Based Rules Performance

whole database history were tested, with the purpose of proving which would produce the optimal outcomes in a scenario, and all possible data were used to train for execution of the best class action.

The Weka tool can create an error matrix and generate a graph plot named Receiver Operating Characteristic curves (McCarthy et al., 2006), which depends on the likelihood gathered throughout an assessment of a classifier's 'actions'. With the aim of visualisation, the graph plot curves are created to conduct investigations. For example, threshold ROC curves can be used to generate confusion matrix data based on evaluation of predictions collected from class actions utilising the Weka tool package. Table data can be set up into a graph plot as an instance of two dimensions of class action, and the plot curve can be enhanced to provide visualisation of data to demonstrate a particular instance.

The ROC curve is related to a fraction of chosen instances. In addition, the threshold curve shows the necessity for decision making to be selected from the whole database history used for a context-aware computing service, in order to determine the predicted maximum probability of an 'action'. An ROC graph plot curve can be structured for trained decision-making classifiers utilising various threshold results. Such a plot curve investigates the capability of the employed classifier to make decisions by showing the False Positive rate against the True Positive rate according to the changing threshold for classification value (Fawcett, 2006).

Figures from 6-9 to 6-16 illustrate graph plots of ROC McCarthy et al. (2006). The graph plots, which are acquired from threshold results between actions, can be used to analyse the performance of each class. The plot data were collected from Table Ad-1 and Table Ad-3 (see Appendix D), which show the confusion matrices from 10-fold cross-validation and holdout percentage split using Naïve Bayesian decision making. The best model result for decision-making is achieved when the value of the True Negative proportion is insignificant compared with the True Positive proportion. Consequently, the important values should be located in the top left-hand side of the graph plot curve, which indicates the capability of a class action to produce better instance results.

## The Smart Home Scenario and Statistical-Based Rules Performance

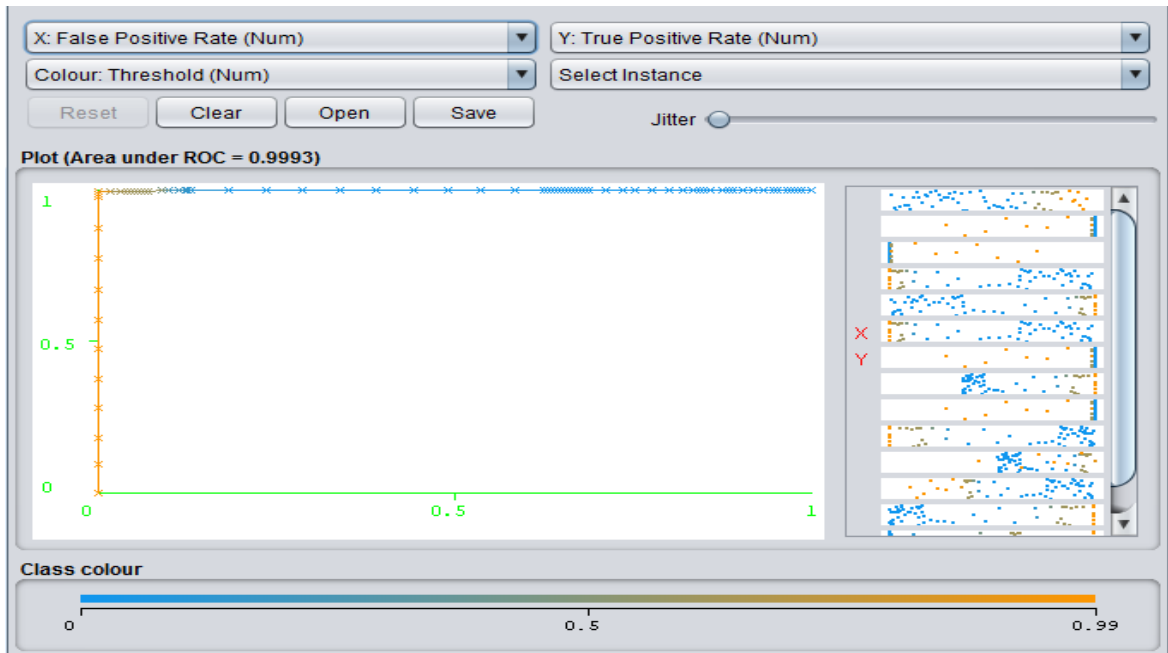

Figure 6-9 Class area OF under ROC curves (10-fold cross-validation of context-aware performance using NB)

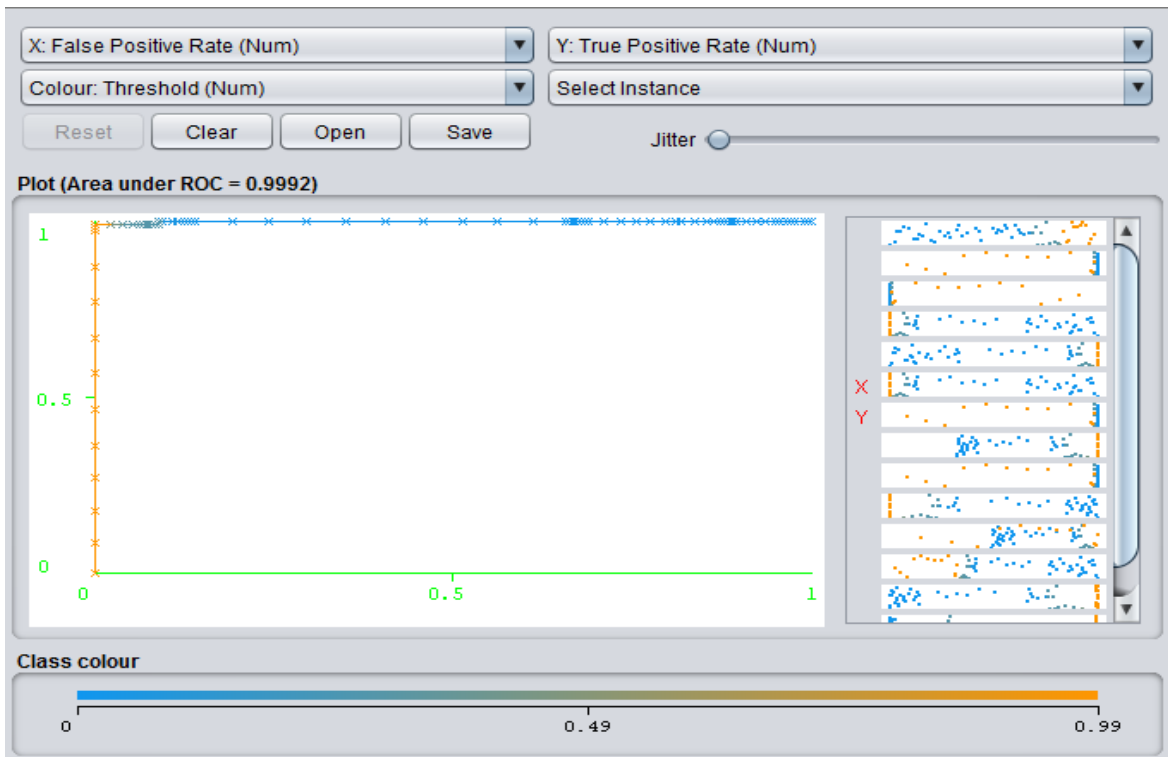

Figure 6-10 Class area WO under ROC curves (10-fold cross-validation of context-aware performance using NB)

# The Smart Home Scenario and Statistical-Based Rules Performance

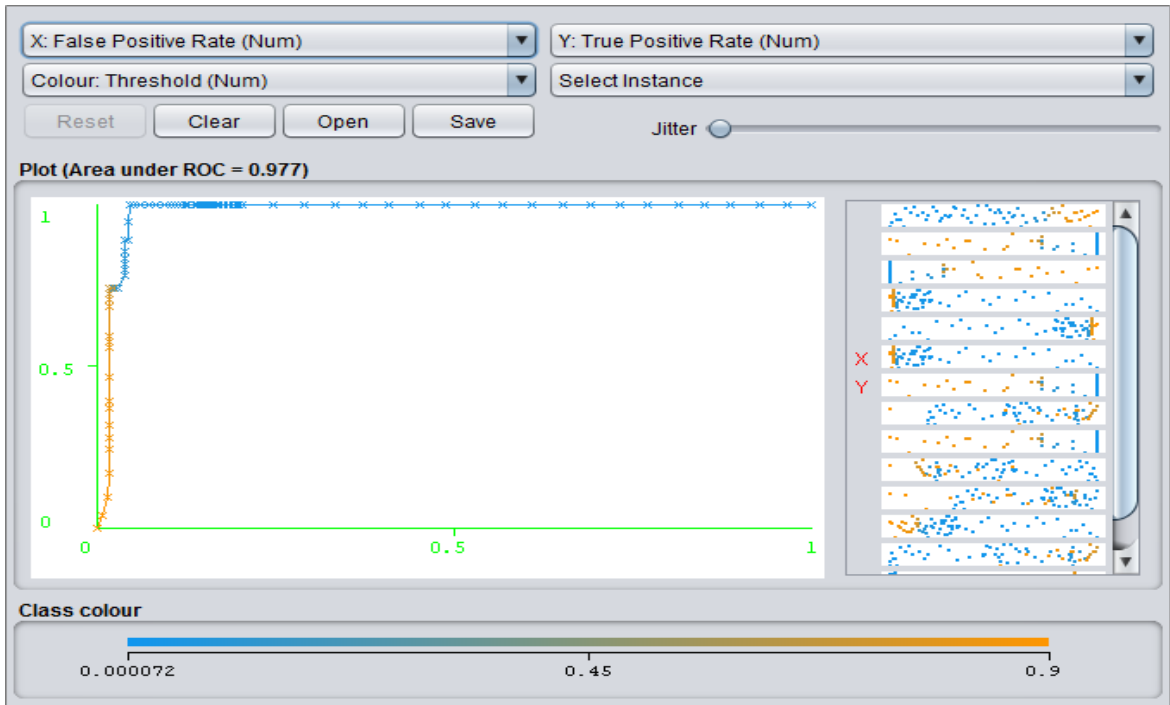

Figure 6-11 Class area WF under ROC curves (10-fold cross-validation of context-aware performance using NB)

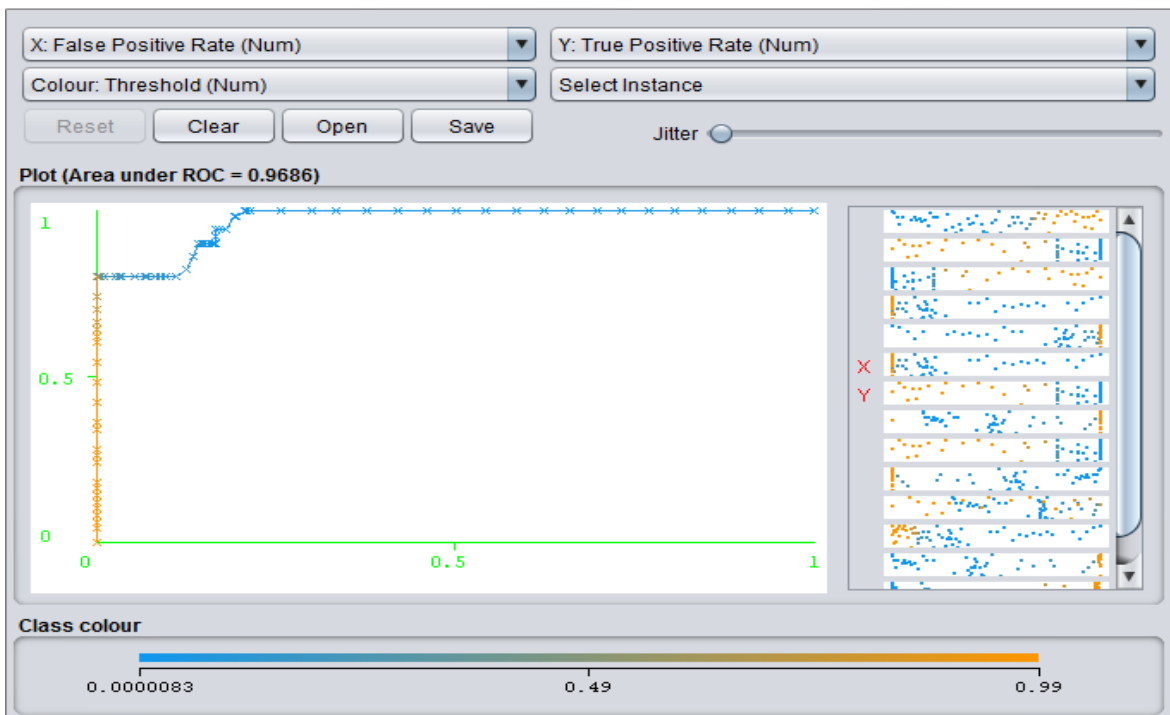

Figure 6-12 Class area FF under ROC curves (10-fold cross-validation of context-aware performance using NB)

## The Smart Home Scenario and Statistical-Based Rules Performance

The graph curves for Naïve Bayes decision results, using both 10-fold cross-validation and holdout percentage, are very similar for class actions Fan ON, Fan OFF, Window ON, and Window OFF. The ROC curves in Figures 6-9, 6-10, 6-11 and 6-12 indicate that Fan ON and Window WO have the highest performance, with ROC=0.9993 and ROC=0.9992 for the 10-fold method, as compared with the other actions FF and WF. The class action of Fan OFF for the same method has the weakest performance, with ROC curve=0.9686. Moreover, compared with other performances of class actions from holdout %, as shown in Figures 6-13 , 6-14, 6-15 and 6-16, the class action Fan ON is slightly above and has better performance, with ROC=1.000, while the action Window OFF indicates the lowest performance in terms of ROC curve, with only 0.9361. After testing all class actions using the Naïve Bayesian classifier as decision method for context-aware computing service actions, and evaluating them with the ROC curve tool, the results illustrate that all the trained class actions were of very high performance and over ROC=0.96, except for the class action Window OFF, with ROC=0.93.

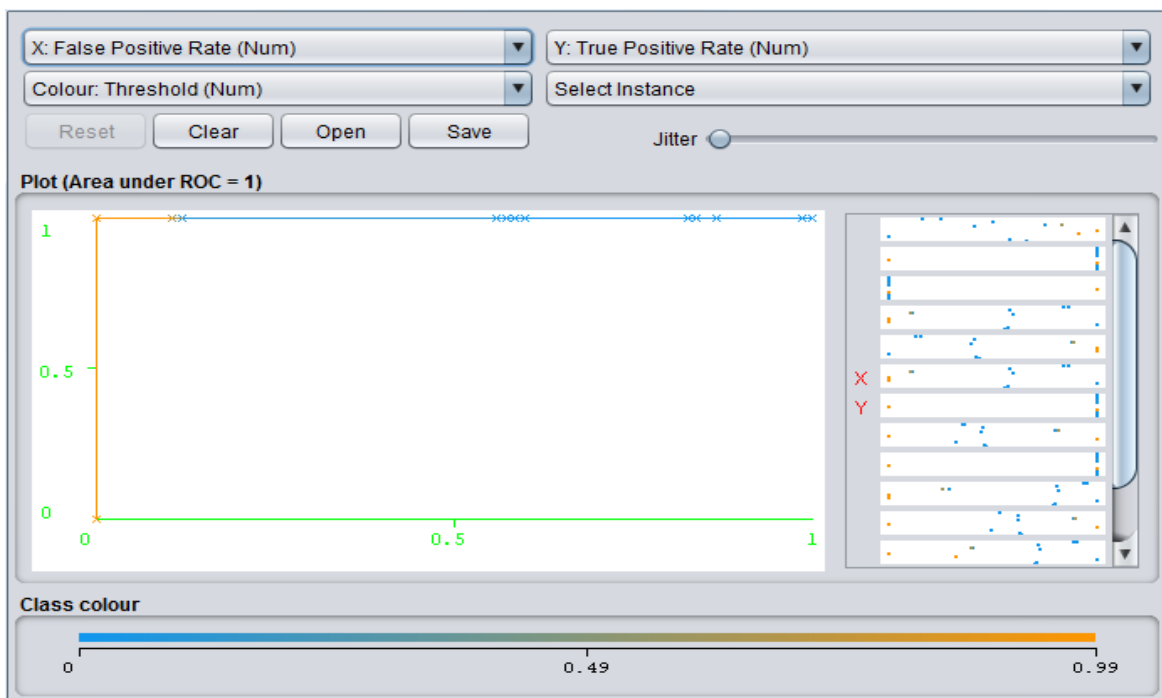

Figure 6-13 Class areas FO under ROC (holdout 66% validation of context-aware performance using NB)

# The Smart Home Scenario and Statistical-Based Rules Performance

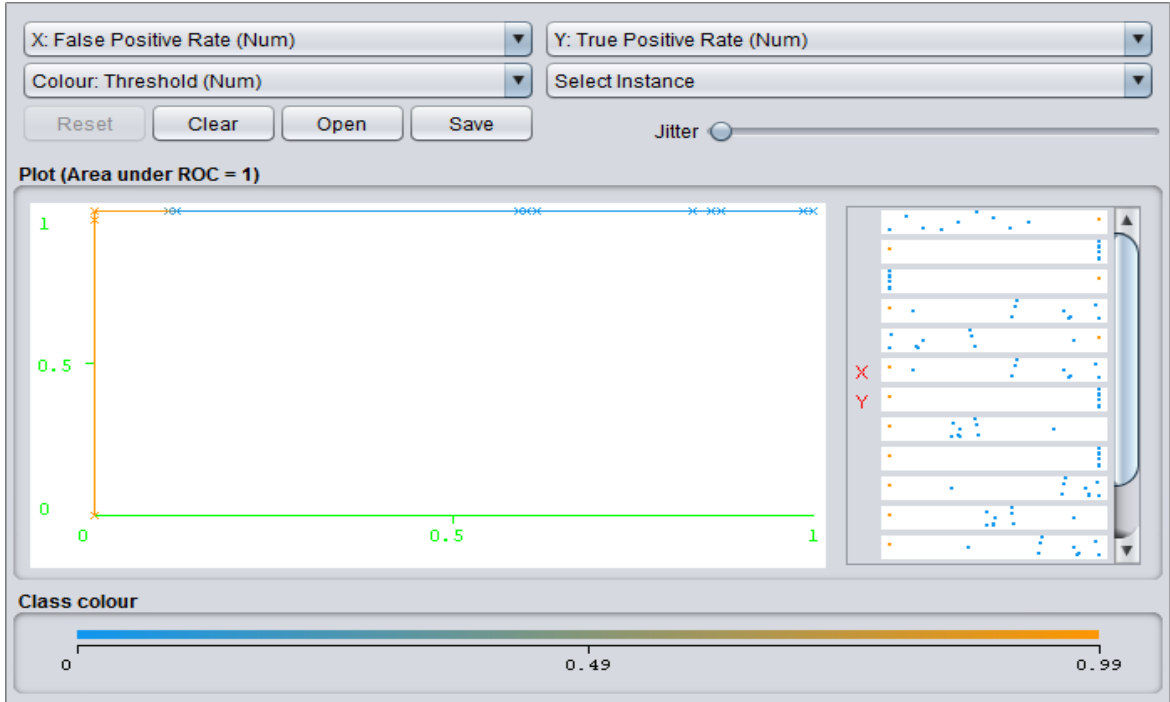

Figure 6-14 Class areas WO under ROC (holdout 66% validation of context-aware performance using NB)

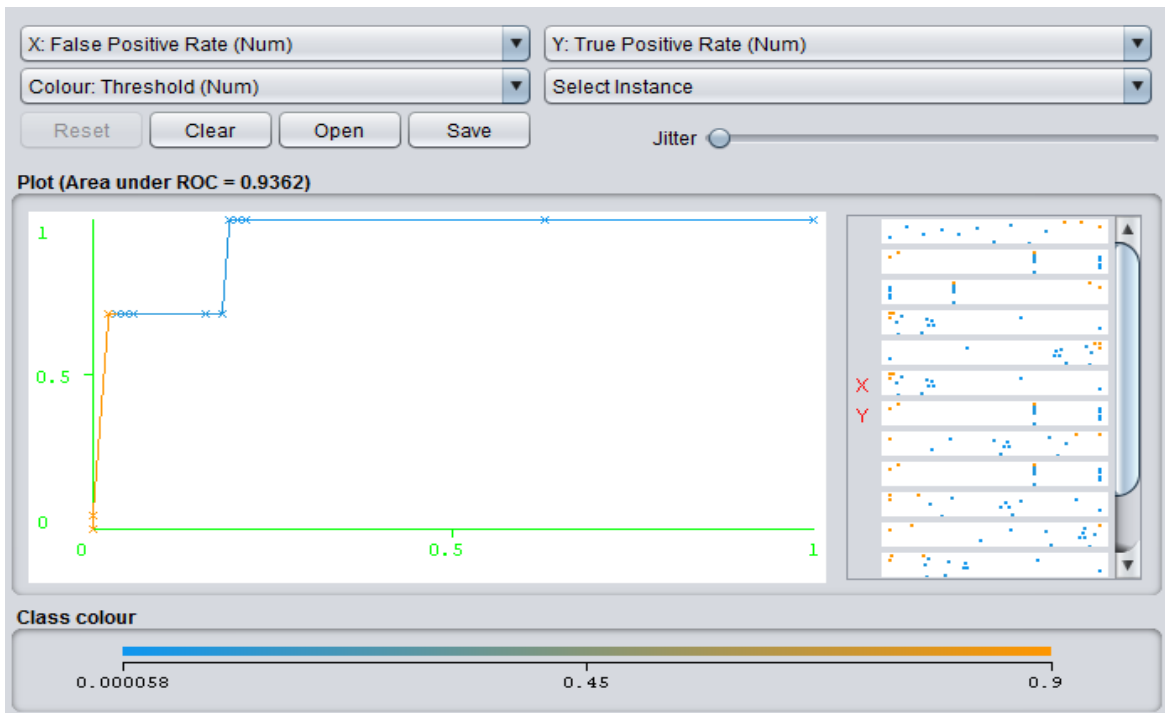

Figure 6-15 Class areas WF under ROC (holdout 66% validation of context-aware performance using NB)

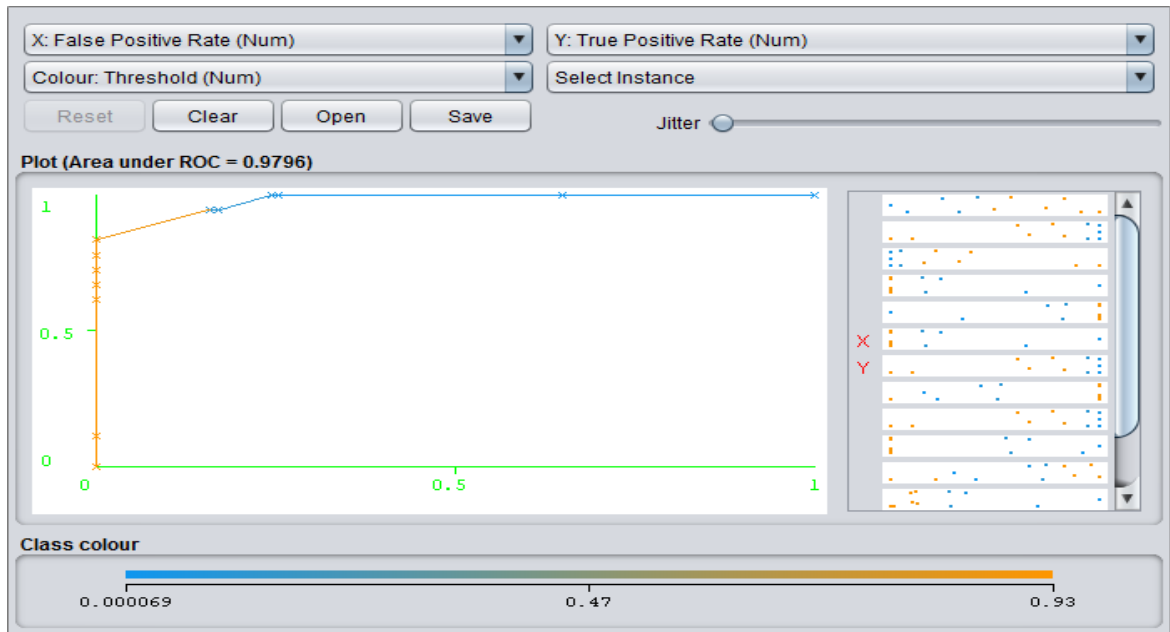

Figure 6-16 Class areas FF under ROC (holdout 66% validation of context-aware performance using NB)

## 6.6 Summary

This chapter has focused on the context-aware performance of statistics-based rules. A comparison between the weights of context attributes in both EF-ICF-IF and Naïve Bayes classifier methods has been presented. Results of Naïve Bayes decision-making rules for action probability, conditionally independent probability and maximum likelihood of each action have been investigated. Machine learning, and particularly the issues of statistics-based rules, have been discussed using the confusion matrix. Moreover, through the Weka tool, training for decision-making classification from a context history database has been validated utilising both k-fold cross-validation and holdout 66%. The visualised threshold ROC curve, taken from the confusion matrix of 10-fold cross-validation and holdout percentage, has also been performed in relation to the Naïve Bayes classifier method. The next chapter will evaluate and discuss four-action decision making based on maximum efficiency of the probability approach implemented in two interface platforms. In addition, it will present the experimental outcome using the Weka tool to evaluate the accuracy of context data.

## **Chapter 7 Evaluation and Discussion**

### **7.1 Evaluation of Naive Bayesian Decision Making Method**

With the aim of achieving maximum efficiency in use of the probability-based algorithm, a service implementation case has been applied and is examined in this chapter. In order to evaluate the time consumption and efficiency of the two different kinds of rules used in the algorithms mentioned in sections 5.2.1 and 5.2.2 (Chapter 5), it is very important to test on two platforms and two interfaces. This will enable the results to be compared in order to determine which has the best efficiency and time complexity. A Previous study which experimented with sensors and actuators in smart home facilities described how the outcomes of repeated tests of the execution of certain actions with different platforms were computed an average of five times for each sample (Dunkels, 2009). Another study reported that all tests of the performance of a mobile device for remote control were repeated five times to demonstrate the continued effectiveness with an increase of sample size (Schneider-Fontan & Mataric, 1998). Consequently, the tests in this research have been repeated five times in order to calculate the accuracy and efficiency of the experiments on the context-aware computing system.

The Naïve Bayesian decision-making method has been tested on two interface platforms, the first being a remote Apache/MySQL/PHP (XAMPP 1.8.1) service on an iMAC machine with 2.16 GHZ Intel Core 2 Duo, 2 GB 667 MHz DDR2 SDRAM, and Mac OS X Lion 10.7.5 (11G63) software. The second platform was a local host Visual Studio/C Sharp 2013 (ASP.NET) framework service on an Intel (R) Corei5 CPU 650@3.20GHz with 16GB installed memory (RAM). The statistics-based algorithm was authorised with the ability to create new maximum probabilities according to the highest weight of context-aware home automation attributes; this would enable the model to adapt to dynamic, real-time smart home facilities. The experiment was carried out in the laboratory at Huddersfield University over a period of five months, which would allow an evaluation of the time complexity for smart home facilities. Due to the complexity of the physical situation in the intelligent building, practical evaluation of this model was associated with many difficulties, particularly as the system involved different kinds of technologies and methods. In this



## Evaluation and Discussion

assessment, the context-aware computing service was executed using methods of probability-based rule control, which is not commonly utilised in this area of research.

IF-statements were used as decision-making logic rules to control the home devices based on maximum-probability functions. Moreover, the experiments concentrated on time consumption (time complexity) in order to determine the effectiveness of the probability methods of the research in the area of supervised home automation. Tables 7-1 and 7-2 illustrate the association between time consumption in executing management of the home facilities and the number of rows in the context-aware database history. This association was considered in order to generate a probability algorithm using both the iMAC machine and Inter Core i5 platform, together with the different functions of eight sensors, to produce the context-aware attributes of the fan and window as in the scenario of the case study. It is also apparent that MAP can then be added to the rule library to supervise the context-aware automation service.

Table 7-1 Time consumption for dynamic, real-time smart home facilities using iMAC

<b>Number of Rows (Samples)</b>	<b>Algorithm Consumer Time (second)</b>	<b>Data Time (second)</b>	<b>Total Time (second)</b>
<b>30</b>	0.006116	0.003324	0.00944
<b>60</b>	0.006908	0.004055	0.010963
<b>90</b>	0.007812	0.004892	0.012704
<b>120</b>	0.008678	0.005695	0.014373
<b>150</b>	0.00932	0.006687	0.016007
<b>180</b>	0.010212	0.007084	0.017295
<b>210</b>	0.011551	0.008074	0.019625
<b>240</b>	0.012147	0.008517	0.020664
<b>270</b>	0.013225	0.009362	0.022588
<b>300</b>	0.014135	0.010099	0.024234
<b>330</b>	0.015891	0.010989	0.02688

## Evaluation and Discussion

Table 7-2 Time consumption for dynamic, real-time smart home facilities using Core i5

<b>Number of Rows Samples</b>	<b>Algorithm Consumer Time (second)</b>	<b>Data Time (second)</b>	<b>Total Time (second)</b>
<b>30</b>	0.015928	0.021122	0.033717
<b>60</b>	0.017273	0.026636	0.045909
<b>90</b>	0.018673	0.030465	0.049138
<b>120</b>	0.020033	0.031229	0.051261
<b>150</b>	0.022552	0.033567	0.056119
<b>180</b>	0.02465	0.036554	0.061204
<b>210</b>	0.026307	0.040764	0.067072
<b>240</b>	0.028255	0.050706	0.07896
<b>270</b>	0.030851	0.057258	0.088109
<b>300</b>	0.035723	0.085317	0.121039
<b>330</b>	0.040492	0.106053	0.146545

These line charts show the change in time complexity of Naïve Bayesian decision making for between 30 and 330 context-aware data rows. Figure 7-1 illustrates decision making using the maximum probability-based rule; generally, the time consumption is shorter when the sample is very small and increases when the number of context row samples rises. However, the increase is more noticeable in Figure 7-2. As the first few rows show, the time taken for algorithm and data preparation increases slightly when the number of samples rises from 30 to 180, when the time consumption is between approximately 0.015 and 0.025 seconds. When the number of context samples reaches almost 270, the time consumption continues to increase slightly, up to 0.03 seconds for data preparation time, but the algorithm time reaches only 0.057 seconds. After that, there is a dramatic increase in data time from 0.057 to 0.1 seconds, though the algorithm time reaches only about 0.04 seconds for data samples between 280 and 330. It is therefore clear that data initiation consumes more time than the algorithm, and that the difference increases sharply with the number of context-aware attributes. Thus, using the Inter Core i5, the total time consumption increases from 0.033 to 0.14 seconds according to the number of context rows.

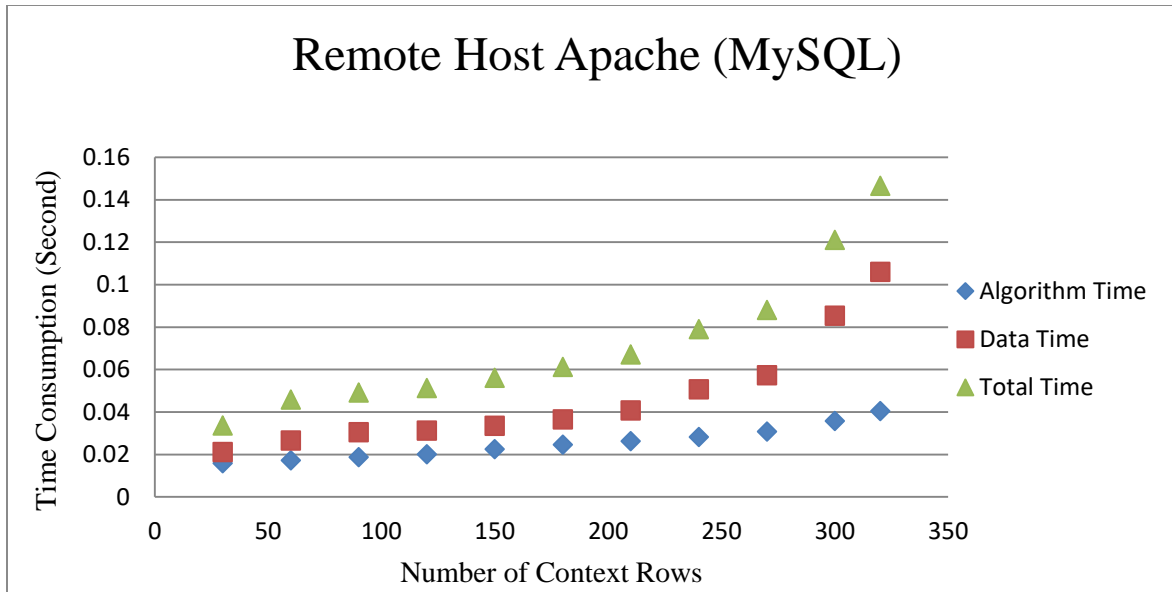

Figure 7-1 Time complexity of Naive Bayes rules on iMac with Apache/MySQL/PHP

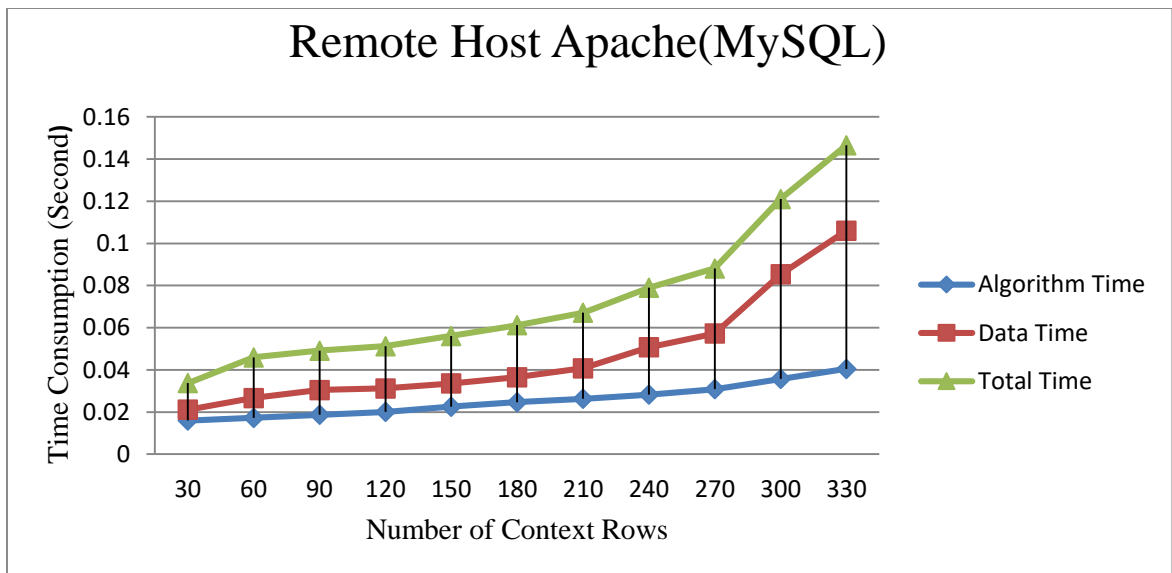

Figure 7-2 Time complexity of Naive Bayes rules on iMac with Apache/MySQL/PHP

The line graph in Figure 7-3 shows the changes in time consumption for both the algorithm and data in Remote Visual Studio. It is faster in comparison with the time consumption of Remote Apache/MySQL/PHP, and the graph is almost linear with the increase in number of context-aware data row samples. The graph also shows a generally slow increase in time consumed, with the algorithm time going up from about 0.006 seconds for the 30 context row samples to approximately 0.016 seconds when the number of rows increases to 330.

## Evaluation and Discussion

Consequently, the processing for execution of home automation using Naïve Bayesian decision making can be achieved within a realistic time for real-world utilisation of a context-aware workstation system.

There is a noticeable difference in the line chart curves between Figures 7-3 and 7-4. The reason for that is possibly that each workstation has a different computation processor; more rapid processors can hold more calculations per second. Moreover, once the computer processing unit is large enough, the execution of the probability-based rule will have better and quicker results.

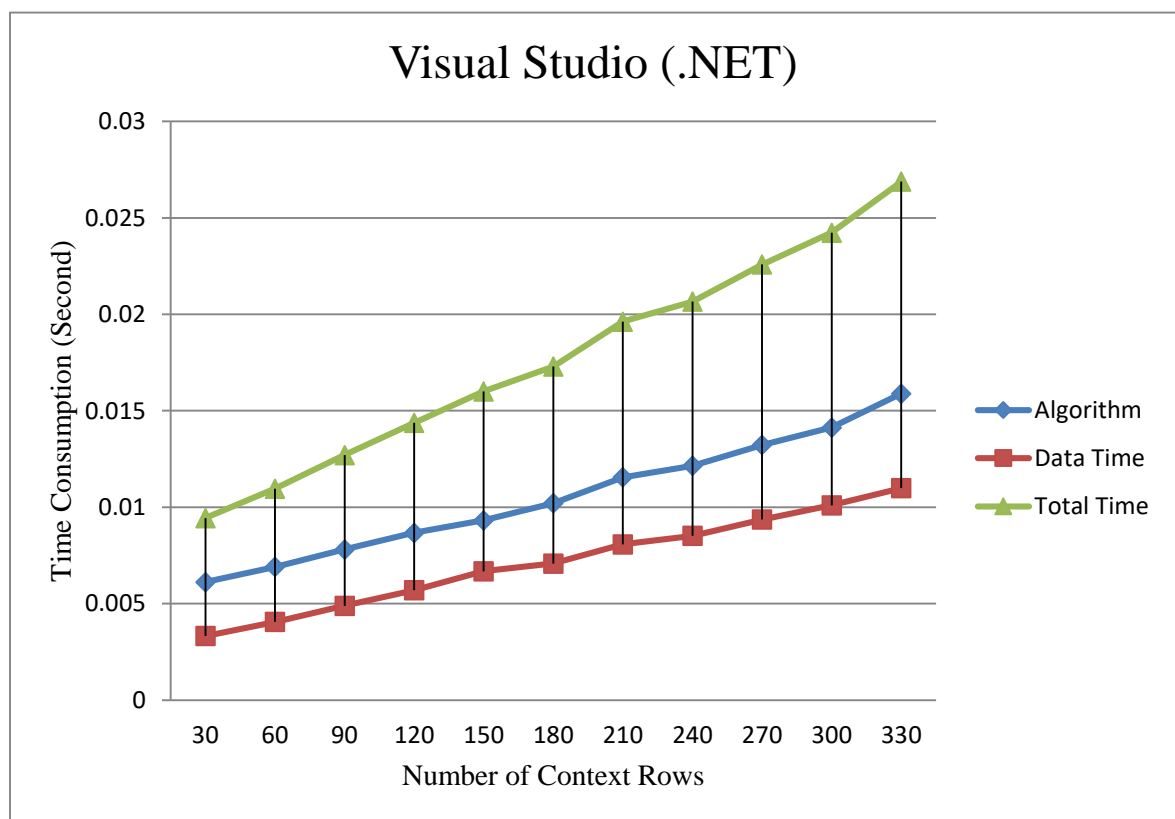

Figure 7-3 Time complexity of Naïve Bayes rules on remote Core i5

## Evaluation and Discussion

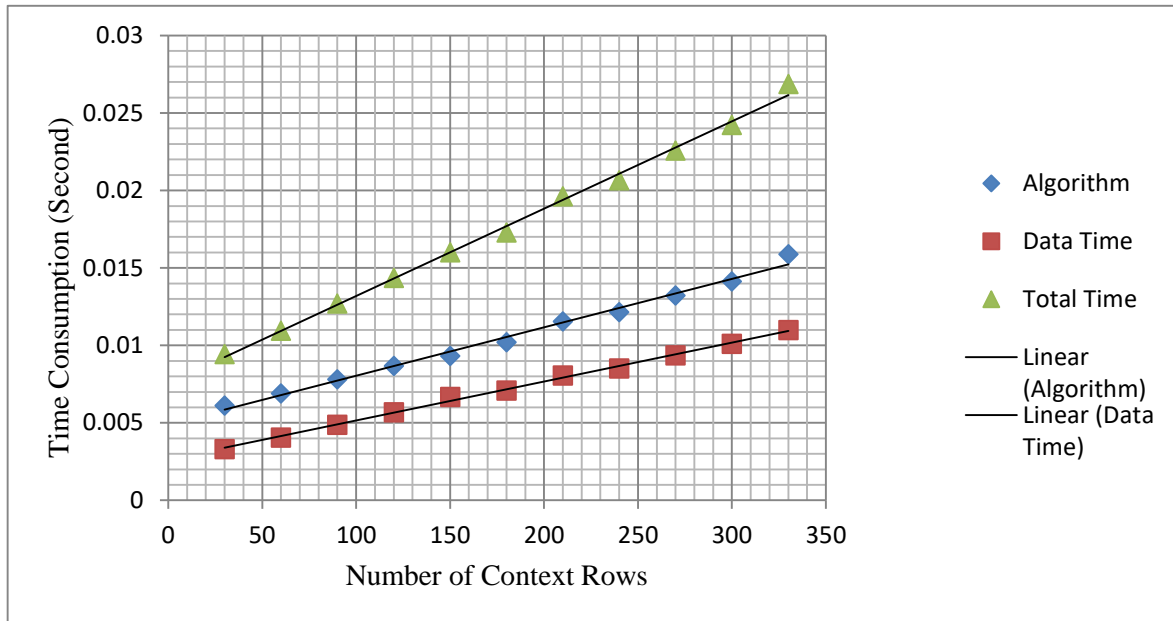

Figure 7-4 Time complexity of Naïve Bayes rules on Core i5

It is apparent that the performance of the system is considerably better on a remote control using Visual Studio (ASP.NET) interface than when using remote Apache/MySQL/PHP. This means that execution of the statistics algorithm is strongly related to the calculation power of the experimental machine and the employment of User Interface (UI) applications. As a result, the examination of probability-based rule processing and procedures of data analysis has been divided into two evaluations: (Vazirgiannis) database history initiation, and (Vazirgiannis) statistics-based rule methods. The database history initiation procedure is the process of database weighting and data query, while the statistics-based algorithm is the procedure of method generation calculation using memory storage which is retrieved from the database history.

Visual Studio 2013 (.NET) and Apache PHP/MySQL have been proposed for implementation of the context-aware computing service for smart home facilities. ASP.NET was utilised to provide a resident interface, which required running C# applications to create some tools and link them with the database history. This interface service was created to collect context sensor data from the database, implementing the statistical computing

## Evaluation and Discussion

methods EF-ICF-IF and Naive Bayesian decision making to execute the home automation service. The interface has been used to investigate the efficiency of the system architecture by measuring the time consumption for operation of electrical devices, and these results have been compared with the execution time using Apache/MySQL.

This approach has been evaluated and discussed in Chapter 7, where the results show that the main target of controlling home facilities through Wi-Fi wireless technology, using both an infrastructure network with the Remote Apache/MySQL/PHP service and an ad-hoc network with the ASP.NET service, has been achieved. Having compared the two existing interface systems, the outcome indicates that the time-consumption utilising Visual Studio/C Sharp is better than the response time using Apache/MySQL service to control the actions of home appliances.

### **7.2 Comparison of the Context-aware Class Action**

The evaluation of class ‘actions’ to investigate decision-making has been mentioned in the previous chapter. Furthermore, these actions have been tested in the Weka tool environment by comparing the Naïve Bayes (NB) with, K-Nearest Neighbour (K-NN) and Support Vector Machine (SVM) algorithms (Fahad, Ali, & Rajarajan, 2015; Ponciano, Pais, & Casal, 2015). This study has utilised the context-aware database history to investigate the performance of action decision-making in the smart home automation service. Various methods have been adopted in an attempt to evaluate and analyse the performance of action factors; for example, the ROC curve and accuracy have been investigated using two cross-validation methods, 10-fold and holdout percentage.

#### **7.2.1 Class Action Accuracy**

This section represents the experimental results for context-aware database sensors in the smart home scenario. Before the database history is implemented, it needs to be organised according to the resident behaviour scenario in order to achieve the best home automation service for the case study, as mentioned in Chapter 6, section 6.1. This scenario describes the actions of the electrical devices, which is important in characterising the elderly people’s activity. This, in turn, is related to the service required in the smart home environment.

## Evaluation and Discussion

The assessment of performance accuracy is performed by the Weka tool and achieved by applying NB, K-NN and SVM to the automated service for whoever lives in the residence. As seen in the graph in Figure 7-5, with 10-fold cross-validation, K-NN provides the greatest performance accuracy in the class actions of switching OFF the window mechanism and fan, but has the weakest performance accuracy of all the algorithms for the class action Window ON. In terms of average performance accuracy, the K-NN method achieves an average result of 0.983, NB decision-making gives an average performance accuracy of 0.9643, and finally the SVM algorithm gives a performance outcome with an average result of 0.982. Appendix D shows further results in Tables Ad-1, Ad-5 and Ad-9.

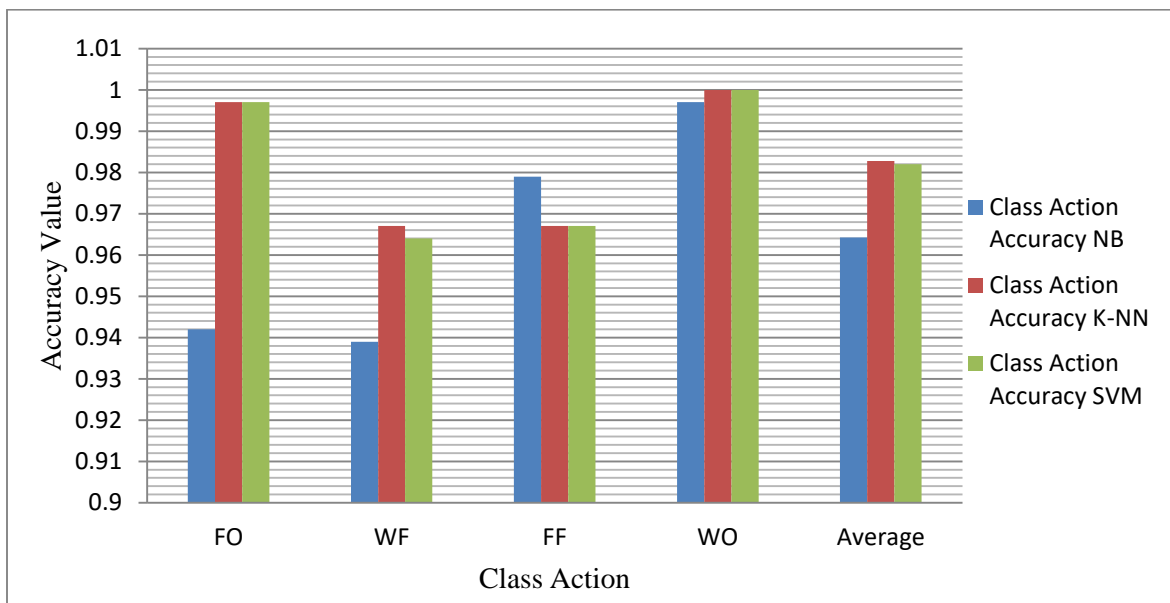

Figure 7-5 Evaluation of accuracy from database history using 10-fold cross-validation

Figure 7-6 shows a plot graph of the performance accuracy of the three different algorithms using holdout method cross-validation. The highest performance outcome among all the methods is in the class action Window ON, with the accuracy result nearly the same, 1.000, for the computing context action service using NB, K-NN and SVM. However, the lowest performance among the methods is in the class action of Window OFF, with accuracy results of around 0.929, 0.973 and 0.964, consequently. These performance outcomes also illustrate that the K-NN and SVM methods have the same accuracy result for the class actions Fan OFF and Window OFF, with a value of 0.973 and 0.964, while Naïve Bayes has a

## Evaluation and Discussion

performance result of 0.973 for the class action Fan OFF and 0.929 for Window OFF. Overall, the K-NN method gives an average accuracy performance of 0.982, the NB decision gives a performance result with average accuracy of 0.958, and finally the SVM algorithm gives a performance outcome with an average result 0.977.

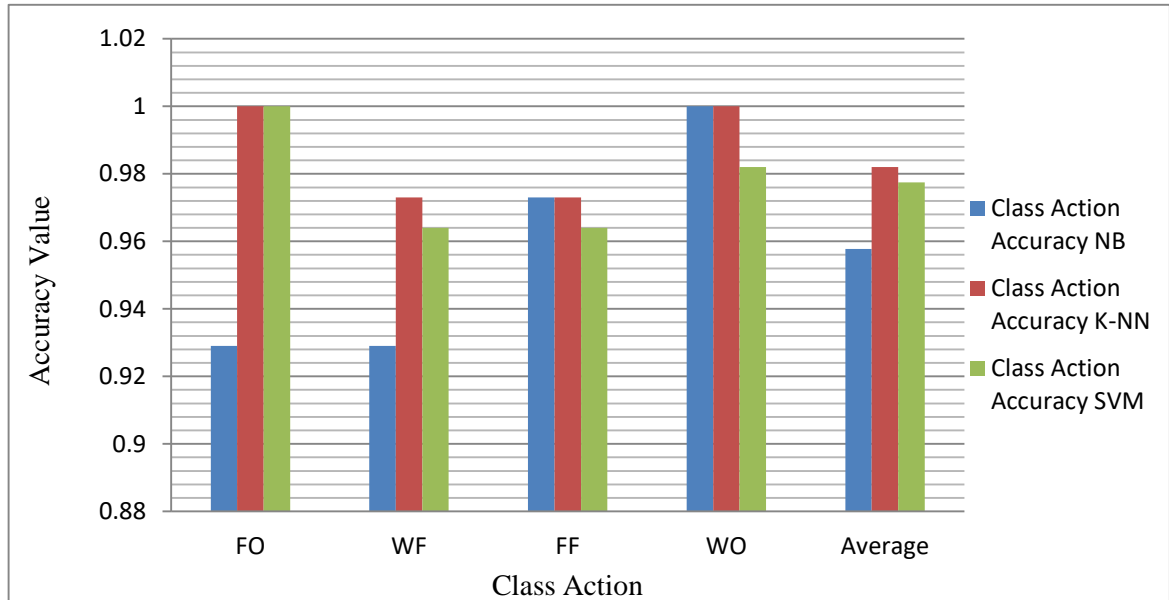

Figure 7-6 Evaluation of accuracy from database history using holdout method

### 7.3 Comparison of the Context-aware Class Action Results Using Weka

The training of classifiers creates the best class actions. All the methods produced sophisticated results, and achieved impressive performances in terms of the ROC curve, especially the Naïve Bayes approach using 10-fold cross-validation. Among the tests constructed utilising various collections of context-aware database history, as seen in Figure 7-7, it is clear that the ROC results from the Naïve Bayes method using 10-fold cross-validation reflect the best performance for the class action Fan ON. The K-NN results are approximately similar to the SVM ROC values in most class actions, such as Fan OFF and Window ON, but slightly different in the class action of Window OFF, with values of 0.979 and 0.976 respectively. Overall, the ROC results using 10-fold cross-validation show that the K-NN method has a higher performance in all class actions, with an average value of 0.993. See Tables Ad-3, Ad-7 and Ad-11 in Appendix D, where more results are illustrated.



## Evaluation and Discussion

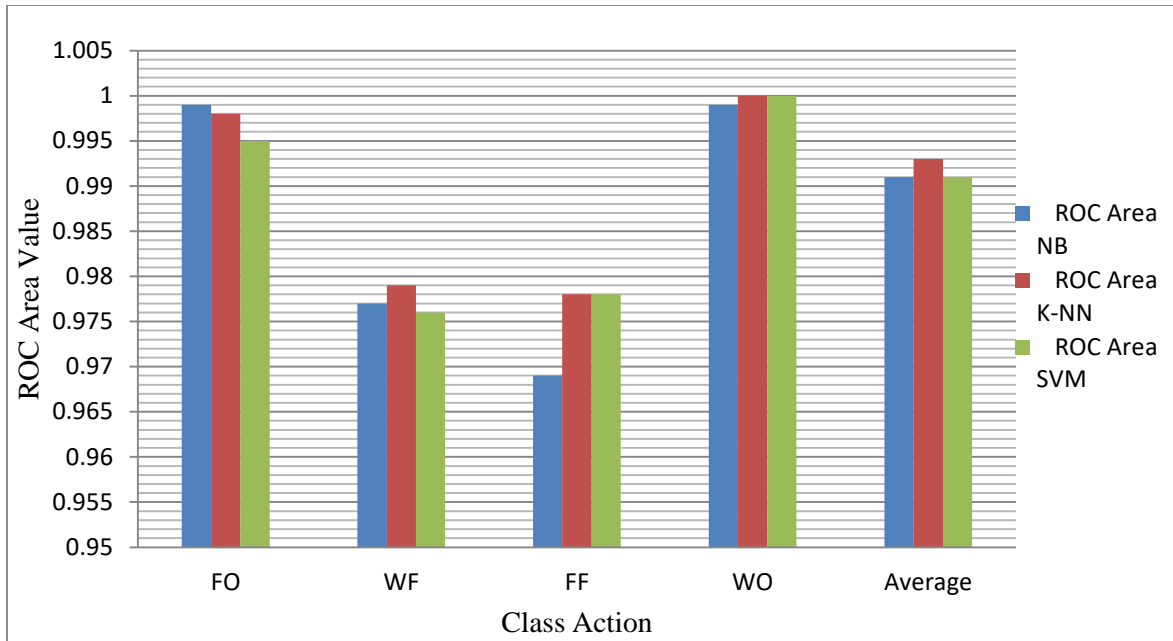

Figure 7-7 Evaluation of ROC area from database history using 10-fold cross-validation

Figure 7-8 shows that using the holdout 66% method, the ROC area performances of all class actions have different results. The class action of turning ON the window-opening mechanism using the Naïve Bayes method has the best performance result, with 1.000. The K-NN and NB methods have the highest performance in the class action of turning ON the fan and Window ON with similar values of 1.000. Additionally, the SVM method has the best ROC performance in Fan ON, with 1.000, while the K-NN and NB models have an identical performance of 0.98 for the Fan OFF class action.

## Evaluation and Discussion



Figure 7-8 Evaluation of ROC area from database history using holdout method

The purpose of analysing the context data using the 10-fold and holdout training tests is to produce an assessment of how effectively the class actions will perform in home automation. In addition, the analysis will provide an approximate level of confidence with a small amount of database history retrieved from the context sensors. Assessment of the three algorithms using both cross-validation methods reveals that the overall results in terms of ROC curve performance using 10-fold cross validation are approximately the same for Naïve Bayes, K-NN and SVM. Close comparison of the results shows that the average ROC curve for each algorithm has values of 0.991, 0.993 and 0.991 respectively. However, the outcome using the holdout method demonstrates that the K-NN method has the highest average value, with 0.991, whereas the NB algorithm has 0.979. [Q14]

### 7.4 Discussion Using Decision-Making Automation and Cross-validation

The work involved in statistics-based personalisation in the smart home can be separated into three stages of computing service. The first stage is the use of a search engine to cross-check the weight of each context-aware attribute value, in order to cross-check the database history record. The second stage is the generation of maximum probability rules based on conditional independence, while the third is the computation of the decision-making service.

## Evaluation and Discussion

The probability model can be utilised to control different appliances in the smart home according to recent context-aware information, after which a new probability rule can be generated with regard to new context data from the home environment sensors. The next calculation in this progression method is to find the maximum probability, after computing the new records using a search engine to find the maximum weight of each attribute value to be used as the items of a new probability rule. The computation of the decision making is easier because of the use of the conditional independence model.

Compared with several existing models, the statistics-based rule can overcome the drawbacks of the decision-making logic rule 'IF-ELSE-STATEMENT' by constructing a model and making the system more typical of the decision rules in the context-aware database history. Moreover, the Naïve Bayesian probability rule solves the problems of data reconstruction and time complexity, thereby guaranteeing accuracy and decreasing the amount of computation. This method is compatible with varied data and is very simple compared with rough set theory, traditional Bayes network, fuzzy logic, and the hidden Markov model. By categorising the data history according to the highest probability in order to generate the rules, only a few samples of context are needed to make the correct action decision. Furthermore, the use of an algorithm to combine two statistical models, EF-ICF-IF and Naïve Bayes decision making, makes the relationship between the two models more accurate in the smart home environment.

When comparing the results of this study with other research work, it is clear that the performance of the probability-based rule gives improved results, especially in terms of time consumption. Meng and Lu (2015) investigated a rule-based service using rough set theory with 100 data samples, for which the time consumption was nearly 0.067 seconds. Another study used a Naïve Bayes classifier to solve the issue of interoperability between heterogeneous devices in smart home automation, and illustrated the response time of the ECA rule using CCTV and main door sensors (Shahi et al., 2015). The experiment was performed for six runs of k-fold cross-validation, and average training data times of 0.1191ms and 0.1344ms were produced for the CCTV and door respectively. In contrast, the performance of the context-aware, statistics-based computing service in this study has

## Evaluation and Discussion

shown the response time using Remote Visual Studio to be approximately 0.016 seconds when the number of samples increases to 330. Using Remote Apache/MySQL, however, the total time consumption increases by 0.033 seconds as the sample number goes up to 330. The combination of a probability-based decision-making service and search engine rules can make executing the service easier when the data has been invoked into an algorithm, as well as very fast in terms of computational performance and implementation. From previous studies in the area of computing services in smart home automation using a model structure, it appears that the relationship between different attributes may be more complicated.

### **7.5 Discussion Using Cross-Validation Methods**

Exploring the accuracy of database history for statistics-based methods and decision making in practical context-aware computing services is generally faced with some difficulties. Context-aware information that is gathered from the home environment by smartphones, or directly from the smart space then transferred to the server, needs to be reduced to fewer samples in order to ensure less computation and greater accuracy. This can be achieved with probability-based algorithms. For instance, data related to the safety, location, activities and home environment of the users should be weighted before being used in the home automation applications. Most investigators seem to be unaware of the significance of investigating the time complexity and effectiveness of context-aware data, because there is insufficient consideration of it in their studies. The speed of computation is a major consideration for real-life scenarios.

This study, which offers decision-making in smart home automation by invoking several devices, could in fact exploit all of them at the same time or only one device, depending on information retrieval from the home environment according to a statistics-based rule. The model consists of sensors with different functionalities and relays to trigger the appliances. The attributes chosen are consistent with representation of the residents' daily activities, and designed to work together with permitted features in the context-aware database history in order to create a proposed model for smart home automation.

Some existing research has already focused on statistics-based rules for making suitable decisions in a smart home automation system. However, there is a need to demonstrate how

## Evaluation and Discussion

the rule for classification of actions can be utilised in training data to generate a computing service model for inhabitants. Adaptation of the Naïve Bayesian method has to be explored in order to execute better decision-making systems. Performance evaluation of error matrices is also required, using two methods, 10-fold cross-validation and holdout percentage split, to measure the accuracy, F-measure, recall and precision of the system and algorithm. Furthermore, it is essential to contrast the performance results with other confusion matrices to enhance the model. This approach can avoid the restrictions present in other decision-making methods regarding the provision of relevant operation among the many devices of the prototype system.

From the experimental results of this research, as well as others' work, it is clear that the number of correct instances for this study's proposed model is high: 92.4242% using 10-fold cross-validation and 91.0714% using the holdout method. The overall average accuracy of all class actions using both methods is 96.425% and 95.525%, respectively. All the outcomes have been mentioned in section 6.5.2. In contrast, the results for NB in a study by (Bin Abdullah et al., 2012) show a correct instance outcome of about 67.67% using 10-fold cross-validation. This percentage will also be reflected in other results such as F-measure, recall and accuracy, because of the calculation of True Positive and False Positive. Generating the confusion matrix by utilising two methods gives a more precise evaluation for the same algorithm than using only one method. This approach shows the accuracy of the database history in all decision-making classes separately. Another piece of research by Ueda et al. (2015) used the Weka tool Meacham learning test with the SVM method, which was also evaluated by 10-fold cross-validation. The result shows that the classification accuracy achieved was 86.9% for ten kinds of activities in room-level position. In a study by (Babakura et al., 2014), the authors proposed the utilisation of HMM and NB to evaluate the accuracy and time consumption of smart home monitoring. They found that for the HMM method, the accuracy was 95.7%, with a time consumption of 0.008ms, while the NB method produced an accuracy of 90.7% and a response time of 0.02ms. Context-aware smartphone music was researched by Wang et al. (2012) for ADL using the Naïve Bayesian model. Their result shows an overall activity classification accuracy of 89.3%.

## Evaluation and Discussion

The performance of this study's model was compared with the outcome of other algorithms from the Weka tool using Naïve Bayes decision making. The experimental work has illustrated that the accuracy outcomes produced using both the 10-fold and holdout methods are very high and promising for efficient decision making in the field of smart home facilities. This is firstly because the database history has been trained many times in order to determine the best model, and secondly, the context data has been gathered from a prototype system, not from the data sets of other work. Thirdly, using both methods of cross-validation to train data, namely 10-fold and holdout, makes it possible to investigate which class action has the highest accuracy and ROC curve performance.

### 7.6 Limitations and Open Subjects

According to the proposed algorithms that are implemented through the scenario of the case study, this research can be supported by a proof of attribute demonstration stage. Subsequently, only one particular computation task has been implemented to find out the feasibility of the algorithms used. The weakness of the general model evaluation is that the accuracy of the context-aware service using Naïve Bayes classification is not as high as for some other methods. Also there are further open issues which need comprehensive investigations. These include:

- 1- The limitations of smartphone devices such as power wastage, small screen size and the affordability and availability of bandwidth for the computing of context data. However, the time response is appropriate for successful smartphone applications.
- 2- The context-aware computing service applications relate to specific domains; therefore, the performance of context-aware applications depends on their characterising of data construction in the real world situation. The specific domain method is utilised to fill the gap between context information and the real world in the prototype system, for which sharing of knowledge and understanding are important.
- 3- Virtually, the context-aware events have made various contributions in the field of computing service decision making. However, it is essential to model the context items by ontology to create a semantic domain for real world situations.

## Evaluation and Discussion

- 4- The statistical-based rules have been implemented on selected samples of context database history to investigate the effectiveness of probability-based rule and real time performance of the system service, which is the most significant task of the prototype system.

Therefore, it is an important investigation task that the context-aware computing services should include the context information to support the machine system in recognising the needs and necessities of residents in order to provide suitable services. The improvement in this related field is typically encouraged by involving different methods and technologies. Thus, further work that addresses the problems mentioned above may encourage the researcher to focus attention on solutions.

### 7.7 Summary

This chapter has outlined how the Naïve Bayesian decision making has been evaluated using two interfaces, i.e., Remote Apache/MySQL/PHP and local host Visual Studio/ C Sharp. The statistical algorithm provided to compute the context-aware automated service was used to evaluate the time complexity of each class action in the smart home facilities. After implementation of the database history in various algorithms according to the smart home scenario, class actions were evaluated to measure the accuracy of each. A comparison was then made of the ROC curve results using both 10-fold and holdout cross-validation applied to the Naïve Bayes, K-NN and SVM machine learning methods.

Finally, the outcomes of practical work and Weka tool experiments have been investigated and discussed. Physical work has been undertaken to measure time complexity using the decision-making logic rule 'IF-ELSE-STATEMENT', where the database history is addressed by the Naïve Bayes classifier method and compared with other results using rough set theory and traditional Bayes network algorithms. With regard to the Weka tool outcome, by considering previous work using cross-validation methods to measure F-measure and recall, it can be said that an impressive level of accuracy has been achieved. In the next chapter, conclusions regarding the objectives and contributions of this thesis will be presented, and possibilities for future work and research in smart home automation will be discussed.

## **Chapter 8 Conclusions and Future Work**

This chapter has been divided into two main sections. The first section forms conclusions about the work accomplished in this research and considers the fulfilment of the early objectives identified in Chapter 1, section 1.5. These first objectives related to how to characterise the technologically advanced architecture for a prototype system. This section, therefore, summarises the use of different layers and the relevant techniques developed for the design, implementation, investigation and evaluation of a context-aware automated service for domestic environments. In the second section, recommendations for further work have been set out and these concentrate on how the architecture model can be improved.

### **8.1 Conclusion**

This thesis began by defining the different kinds of context-aware information, equipment technologies and related to the design of applications to monitor and control smart home services. Such systems are operated through a smartphone and personal computer to perform routine activities; they are also able to sense unusual patterns during daily activity. This research has offered a comprehensive wireless system from the smartphone host user to the end appliances used by an older or disabled person in the home. In addition, different matters such as methodology and technologies in the smart home have been explored. Four levels of model framework design have been described according to their implementation in the smart home environment. The system architecture has been integrated by means of technology for building software and hardware systems, as well as a user interface consisting of a smart phone and PC designed to be simple to utilise for ageing people. The literature review has considered recent studies in the area of smart home environments and scenarios, particularly those concerned with activities of daily life for the elderly, which are discussed in Chapter 2, sections 2.5, 2.6 and 2.11. As part of the research, the literature review has also involved a consideration of several sensor techniques, wireless adapters and the methodologies adopted, as well as the challenges associated with this sector, such as the cost of technologies to design and implement a prototype system for smart home automation.



## Conclusions and Future Work

- 1- To design a general prototype system architecture using raw context data from sensors (second objective)*

Many investigations have been carried out in this study in order to design the prototype system and thus achieve the main target of the research. Firstly, work has been done on the design of the model system, such as the process of gathering data from sensors and transferring it to the PC through the MCU and Wi-Fly adapter. The second stage was the programming of the iPhone SDK using the TCP/IP socket to communicate between the Wi-Fly and iPhone 4 in collecting information from sensors. The third stage was to set up the network connection between the wireless adapter, wireless router and server. When this had been completed, it was necessary to create a MySQL database table and receive the script language code run by PHP. Finally, with this network connection, the sensor data from the mobile phone could be sent to the server and saved in the database for use in computing tasks. This process has effectively achieved the first objective, as mentioned in Chapter 3, sections 3.1 and 3.2, regarding design and implementation.

Rather than concentrating on one particular domain, such as system architecture or technologies, this work has aimed to implement a classified context-aware model utilising clear and explicit functions. This model has been designed according to the attributes of context raw data supervision and context provisioning services. The heterogeneous requirements of different devices in the low layer, as well as weaknesses in terms of efficiency and time complexity have been regarded as critical difficulties in this field. For that reason, it was important for the system architecture to be able to reduce the time consumption and improve the efficiency of the application. Moreover, the construction of the prototype system highlights the utilisation of context data by providing a database history to determine the weighting of context items, and to generate the maximum a posteriori probability for the decision-making service. The system outcomes achieved in this study are evaluated in section 7.1.

## Conclusions and Future Work

- 2- *To investigate the use of wireless adapter and Wi-Fi devices with both ad-hoc and infrastructure networks (third objective)*

Another important part of the prototype system presented by this thesis is the monitoring and remote control of appliances using smartphones and low-cost commercial sensor equipment. The model incorporates sensors, actuators, wireless adapter (Wi-Fly RN-370) and computer service for remote control in the smart home environment. This model has been investigated both theoretically and practically and therefore, some appliances are involved in the prototype, such as actuators to control the fan and window using the smartphone to assist the occupant. The ad-hoc and infrastructure wireless networks have been explained and the smartphone applications between the end user and computer service have been tested in practice. The use of an iPhone SDK, with a TCP/IP socket to communicate between the Wi-Fly and iPhone to collect information from sensors and control the home facilities from a range of distances, was successfully tested. This research then goes on to concentrate on the performance of the prototype context-aware system in the remote control of home appliances (testing and evaluation of the smartphone applications are discussed in Chapter 4, sections 4.6.1 and 4.6.3).

- 3- *To explore context-aware thresholds, modelling and computing service methods appropriate for smart home facilities (fourth objective)*

The use of a statistics-based rule within the context-aware computing service is described in Chapter 5. This research has investigated the potential of combining a statistics-based rule with a context-aware database history to provide a personalised service for control of electrical devices in the smart home. This has been achieved using low-cost commercial sensor technologies, wireless embedded systems, actuators and a smartphone. A context-aware system architecture has been modelled using low-level sensors together with adaptable smartphone applications based on inhabitants' situation and perceived context. The methodological approach adopted was to design the model with both low and high levels. The low level was used to extract important features from the smart home environment through various sensor technologies. A hybrid of machine learning and search-engine methods was then used to recognise an advanced, high-level, context-aware database

## Conclusions and Future Work

history in order to deploy it reliably for decision-making methods. The high-level work involves what is known as a statistics-based rule, utilising both the EF-ICF-IF method and Naïve Bayes decision making. This was achieved in three stages: (a) finding the algorithm that would extract accurate weights from context-aware attribute items; (b) gathering and re-ranking the frequency of items with respect to the smart home surroundings; and (c) designing and implementing the statistics-based rule. The processes in (a), (b) and (c) are presented in Chapter 5, sections 5.2.2 and 5.2.3. The aim of the investigation was to make the process more reliable, and to increase speed by reducing the computation of probability rules based on Naïve Bayesian decision making in accordance with the smart home inhabitants' situation (outlined and performed in section 6.3.3).

The statistics-based rule, based on EF-ICF-IF and Naïve Bayes decision algorithms, is utilised to achieve the maximum a posteriori probability from the context database history provided in the service repository. The statistics-based method using conditional independence is appropriate for coping with uncertain sensing and incomplete context data. Clearly, it is important to determine the best potential method which will allow the context-aware system to be flexible and suitable for adapting to changes in the smart home environment.

- 4. To classify in depth, the total weighted context data and the corresponding context acquisition method by applying a search engine using EF-ICF-IF (fifth objective)*

By deploying an appropriate search engine as the method for retrieving information and weighting context attributes, the context information from mobile sensing applications can be ranked and classified. The context-weighted items can be used within the evolving sensor information in the context-aware computing service model. The search engine's function is to derive the context items' weight using EF-ICF-IF, as described in Chapter 5, section 5.2. This achieves different, distributed information results from the physical real-world environment, and this information can be utilised as new context data, as in Chapter 6, section 6.2. An applicable method and design model was needed for well-organised management of context data and effective provision of the context-aware computing service.

## Conclusions and Future Work

The results of analysis have shown the planned method to be very suitable for future use in context-aware personalised services.

The proposed algorithms for context information retrieval consider the context weighting of items, where context attributes and resident activity are input and the context automation decision is output. The context-aware search engine compares the context probability classifications, using the ranking weight of items to search for the dynamic rule for decision making. This algorithm is appropriate for context data and for context-aware applications in the smart home situation. The planned method and the results of the analysis are very suitable for future use in the provision of context-aware automated services.

### *5. To deploy Naïve Bayesian classification to perform action decision-making in smart home automation (sixth and seventh objectives)*

The evaluation and results have demonstrated that the proposed probability-based methods are practicable for controlling the applicable computing service and computational complexity of the decision-making algorithm for a computerising context-aware service. The efficiency of the probability-based rule was tested with data, from a database history, using various platforms to determine the time complexity and effectiveness. The Naïve Bayesian decision making and search engine methods were found to be suitable choices for a prototype system to trigger related devices within the smart home without interaction from the residents. Finally, an evaluation of performance based on an experiment with 330 samples found that the process took slightly longer than 0.01 seconds. The test outcomes show that the proposed algorithms were successfully applied to the data with an initial time complexity of 0.003324 seconds only. These results are evaluated in Chapter 7, section 7.1, as one of the main contributions of this thesis.

In this research two aspects, the accuracy and the effectiveness of the system, have been evaluated, results of which can be found in Chapter 6, section 6.4. The proposed algorithm was tested using the Weka tool with both 10-fold cross-validation and holdout percentage split methods to measure the accuracy of the decision making for each class action. The algorithm is designed to be appropriate for any weighted value of an independent condition, based on the Naïve Bayes network approach. To ensure this, all weighted terms were

## Conclusions and Future Work

collected according to the case study of daily life in the smart home environment. Data were retrieved from eight types of sensors and saved in the database history according to the prototype system architecture, then trained and tested with regard to four class actions to discover confusion matrix problems. The outcomes of the experiment indicate that accuracy in data collection and in the statistics-based rule can increase the accuracy of performance in terms of action decision making.

In the experiments mentioned above, the outcomes were high for F-Measure, True Positive, Recall, Precision, Accuracy and ROC curve area. Moreover, simulations using both cross-validation methods illustrated that the Naïve Bayesian classification resulted in higher accuracy and specificity for Fan OFF (FF) and Window mechanism OFF (WF) than Fan ON (ON) and Window mechanism ON (WO). The proposed algorithm was performed in two environments to measure the time complexity and accuracy of the context-aware database history. The first experiment, which was done as a simulation with the Weka tool using 10-fold cross-validation and the holdout method, illustrated a significantly good rate of accuracy. The second experiment was implemented in a different practical prototype system, and the time complexity and effectiveness were compared to those achieved by other existing algorithms.

The results in this study have been obtained through construction of a context-aware database history and classification of actions, as well as through deployment of the Weka tool to analyse performance accuracy using two methods of cross-validation. Furthermore, these experiments have been tested in the smart home environment, utilising Naïve Bayes, K-Nearest Neighbour and Support Vector Machine, as mentioned in Chapter 7, section 7.2. One of the evaluations of this experiment illustrated that, for the four class actions employed in this test using the Naïve Bayes model, the run-time for execution was identically fast with both cross-validation methods. The Naïve Bayes model produced a number of actions from the context data and indeed, Naïve Bayes decision making may possibly be considered a better model because of the better values it achieved from performance evaluators, especially the ROC area curve and other accuracy results relating to class actions. The performance accuracy of class actions such as Window ON, Window OFF, Fan ON and Fan

## Conclusions and Future Work

OFF have been evaluated in accordance with the scenario of elderly people in the smart home environment.

### 8.2 Learning Skills

In this research, various devices, technologies and methods have been implemented in order to achieve a context-aware computing model. This model is described within a comprehensive system architecture and research methodology, as seen in Chapters 3 and 4. It deploys different technologies and tools, which include actuators, sensors, a microcomputer unit and a wireless adapter. In addition, this system includes a smartphone, which is built with two interfaces for monitoring and controlling the home environment and facilities.

#### 8.2.1 Devices and Wireless Communication Networks

##### 1- Actuators and sensors technologies

The main function of an actuator is as a controller to switch ON or OFF facilities such as an electrical appliance according to the context-aware computing service. Moreover, sensors are electrical appliances which are utilised to convert physical actions into digital form, and so collect information about the context. There are different kinds of context data; some are collected from the ADL environment, for example, the human body context, obstacle avoidance context and distance context. Several contexts are gathered from the home environment, for instance the brightness context, smoke context, temperature context, humidity context and distance context. The details of these are presented in Chapter 3, section 3.1.1. Moreover, the smartphone appliance is embedded with sensors to collect data about contexts such as the accelerometer context, microphone and sound context, and video context.

##### 2- The MCU controller

The MCU controller is used for pre-processing raw data, which is shared with In-system Programming (ISP) and the In-System Application (ISA), the Digital Signal Processor (DSP) and Advanced RISC Machine (ARM). These all co-operate in gathering the context data and communicating the sensor information into the Wi-Fi adapter to be adapted with a

## Conclusions and Future Work

Universal Asynchronous Receiver Transmitter (UART), as shown in Chapter 3, section 3.1.2.

### **3- Wireless communication adapter (Wi-Fly RN-370M)**

The Wi-Fly RN-370M converter is used to communicate the signal from analogue form to a digital form that allows the combination of various communication applications within the context-aware model. For example, the wireless adapter converts the signal from RS-232 raw data into a Wi-Fly signal. In the project, this is done in the low-layer (physical level), which is connected to Wi-Fly RN-370M (Network, 2011). Detail concerning this wireless adapter is presented in Chapter 3, section 3.1.4.

### **4- Smartphone appliances**

The smartphone device has been used for two interface applications, one that monitors the home environment, and one that controls home electrical devices. The mobile phone plays a very significant part in this research, as illustrated in section 3.15 and section 4.4.1. This is because it is used to characterise the human body preferences, resident context and home environment context; in other words, it is the phone which makes the service personalised. In this investigation, the smartphone is involved in interactions using any combination of touch screen, microphone, camera and internet network.

### **5- Wireless connection with Ad-hoc and Infrastructure Networks**

Ad-hoc and infrastructure networks have been used to enable the wireless communication of raw data in the context-aware model, so that sensors and appliances can be adapted to residents' daily lives and the home environment in the most convenient way. The raw context data is acquired and serviced to be performed in a wireless situation, as in section 3.2.3. In these communication networks, there are two kinds of connections, HTTP and TCP/UDP sockets, between the mobile phone and the PC. These techniques are utilised in the smart home prototype system with the aim of controlling home electrical devices within the scenario of elderly people.

### 8.2.2 Context-Aware Computing Service Platforms

In this research, the model context-aware computing service with mobile interfaces is provided with end-user computing service platforms. These platforms, where the raw context data is gathered and saved in storage as database history, are Apache HTTP, using the MySQL PHP service, and Visual studio (.NET) with C sharp. These kinds of services have been produced so that they will work with search engine (EF-ICF-IF) and machine learning (Naïve Bayes classifier) methods, depending on the existing context-aware data, database history and either human interaction or robotic supervision.

#### 1- Service application using Apache HTTP:

Apache is commonly utilised as web server software. Apache HTTP is open source software, accessible for any researcher to download. It can be easily and very flexibly adapted to meet the requirements of various environments and applications by using modules. In this research, the service model has been built to deal with the context-aware computing service and Microsoft internet data service. The sensor technologies and smartphone are used to interact through various methods, such as context update and context query. This information is stored in the database history for future reference.

#### 2- Service application using Visual Studio (.NET):

Visual Studio (.NET) is an integrated platform development environment. It is used to create applications services with various structures. It has many concepts, with an intelligent editor built into the compiler and a context computing service. C sharp is a platform language that can be used to build different types of frameworks. Here, the C sharp language has been used to interact with the iOS mobile phone and desktop applications. These applications have also been created to work with statistics-based rules in order to implement the information retrieval (EF-ICF-IF) method and Naïve Bayes decision-making algorithm based on the context-aware computing service, as mentioned in Chapter 5.

### 8.2.3 Basic Rules and Methods

Various theories are described in Chapter 5 relating to the personalisation and supervision of smart home conditions through a context-aware computing service. The collection of raw



## Conclusions and Future Work

context data, context reasoning and context distribution must be in a form compatible with the context-aware service, so that algorithms can address the context automatically. Thus, relevant models and methods have been implemented in this system in order to achieve a sufficient level of context information and the most effective outcome.

It was necessary to adapt the computing service to the smart home situation. This process required the efficient collection, evaluation and distribution of data. It was also necessary that the context-aware service had enough learning capacity to deal with a changing and developing context. Suitable theories and design models were therefore needed for efficient management of data and effective provision of the context-aware service.

### **1- Context-aware normalising**

Normalising has the aim of providing raw data within the context of human issues and transforming these into the context-aware automated service. The raw context data should be normalised before context distribution and computation. This normalising of data has been performed by the threshold method described in Chapter 5, section 5.1.1, in order to create data within the same range of values as the database history, as shown in Table 4-3.

### **2- Context-aware modelling and reasoning**

After normalising the context data, the next step is to classify the relevant information from the smart environment. Classification means that the data are consistent with their characteristics and sources. The raw data modelling processes are discussed, together with details of the design and implementation of the system architecture, in section 3.6 and section 5.1.2. Moreover, the context-aware service has been created in the high layer, which is not directly related to the source of the context data.

### **3- Context-aware personalised service**

The context-aware model and computing service have been implemented, according to the context environment and statistics-based rules, to be appropriate for one specific person. The theories adopted should be able to handle the heterogeneous context data and arrange a suitable computing service. The fundamentals of the context-aware computing model are mentioned in Chapter 5, section 5.2.4. The model has been implemented to provide a

## Conclusions and Future Work

framework of context-awareness which will enable personalisation of the service. Consistent with the computing service model, a statistical computing service rule has been proposed. The conditional independence requirements for a Naïve Bayesian classifier and decision-making algorithm, which affect the context-aware computing service in the smart home situation, are also described in Chapter 5.

### **4- Information retrieval using search engine**

The search engine utilised for information retrieval by EF-ICF-IF should be able to create new context data according to the weighted terms. The EF-ICF-IF term weight has been extended to enable the database to work with pages of context-aware information, rather than with documents. Each page consists of 30 rows, but each line has different values of sensor data which can describe the context-aware features, as explained in section 5.2.

### **5- Machine learning using supervised methods**

In addition to the previous rules, this system has been implemented with another method to enable supervised service provision, which is the Naïve Bayes decision approach described in section 5.2.3. This theory is used to create decision making in the smart home situation. Furthermore, two cross-validation methods, 10-fold and holdout percentage, are investigated in Chapter 6. The machine learning algorithms K-NN and SVM have been used to determine the confusion matrix in order to find out which has the higher accuracy, as illustrated in Chapter 7, sections 7.2.1 and 7.3. From the scientific knowledge, technologies, platforms and system architecture designs that have been investigated, this research has evaluated and formed conclusions in accordance with implementation of the model within the scenario of elderly people.

Effective interaction between two devices using machine learning has been created, and this relationship is dependent on classification. Raw sensor data from the smart home environment is used to determine the switching ON or OFF of actuators. The approach of pre-processing raw sensor data can be utilised to anticipate device actions. This prediction from pre-processed sensor data is then used to inform decision-making about the condition of the smart home facilities. Next, this decision-making is utilised to determine appropriate

## Conclusions and Future Work

commands for dynamic action by actuators. Finally, optimisation of the two aspects of decision-making and appliance control is derived from a clear loop construction between low-level and high-level system architecture.

### 8.3 Future Work

A number of concepts have been mentioned in this research which highlight important applications, such as context-aware smart home environments, statistics-based methods, smartphones and context-aware computing services. There are, however, still several aspects that deserve advanced consideration in future research related to this field. Context-aware computing services in the intelligent building is a significant research field, particularly for elderly people who live individual, and the target is to provide both a good service and low cost by employing advanced technologies and methods. In order to more comprehensively achieve the target of this study, there are still some difficulties which need to be further addressed, as summarised below.

- 1- The next stages should be to set up a new network connection Wi-Fi CC300 over the wireless router (TP\_Link\_48F3B8), and to use a more advanced embedded system such as Texas Instrument MSP-EXP430FR5739. Preliminary steps have been taken with regard to this MCU in order to use it in the next prototype. Moreover, it is important to investigate a variety of attributes that could be utilised as features of decision-making in the smart home facilities. These features include context data from sensors already built into smartphones, as well as information from web services.
- 2- The statistics-based rule for selecting the suitable frequency weight of items could be improved by optimising the hybrid methods based on real-world system performance and computation power of the workstation.
- 3- Quality of Context (QoC) is one of the most important concepts in the field of computational smart home services, and there should be further investigation of how effectively systems can adapt to residents in order to make appropriate decisions.
- 4- A comparison is needed between the context-aware computation methods required for designing a comprehensive model for execution of a personalised service, and

## Conclusions and Future Work

those appropriate to other changes in activity, such as wireless location, indoor navigation and responding to inhabitants' expectations. Another future piece of work could be to compute algorithms to investigate reliability and usability in relation to dealing with information from various sensors and the control of electrical devices.

- 5- In order to determine a more reliable prototype model in the future, further work is needed to make this framework relevant to the Internet of Things (IoT). This would enable it to deal with user activity, both indoor and outdoor, by using smartphone and context-aware decision making using raw data sensors.

Among the future works mentioned above, the main issue is to continue to increase the accuracy of decision-making, in order to increase the comfort of smart home residents. This suggests there are still some significant challenges ahead, which will rely on further use of probability-based rules and the most advanced technologies.

## References

### References

- Aggarwal, J. K., & Ryoo, M. S. (2011). Human activity analysis: A review. *ACM Computing Surveys (CSUR)*, 43(3), 16.
- Al Mehairi, S. O., Barada, H., & Qutayri, M. A. (2007). Integration of technologies for smart home application (pp. 241-246).
- Alam, M. R., Reaz, M. B. I., & Ali, M. A. M. (2012a). A review of smart homes—Past, present, and future. *IEEE Transactions on Systems, Man, and Cybernetics, Part C (Applications and Reviews)*, 42(6), 1190-1203.
- Alam, M. R., Reaz, M. B. I., & Ali, M. A. M. (2012b). A review of smart homes—Past, present, and future. *Systems, Man, and Cybernetics, Part C: Applications and Reviews, IEEE Transactions on*, 42(6), 1190-1203.
- Alemdar, H., & Ersoy, C. (2010). Wireless sensor networks for healthcare: A survey. *Computer Networks*, 54(15), 2688-2710.
- Alheraish, A. (2004a). Design and implementation of home automation system. *Consumer Electronics, IEEE Transactions on*, 50(4), 1087-1092.
- Alheraish, A. (2004b). Design and implementation of home automation system. *IEEE Transactions on Consumer Electronics*, 50(4), 1087-1092.
- Anagnostopoulos, C. B., Tsounis, A., & Hadjiefthymiades, S. (2007). Context awareness in mobile computing environments. *Wireless Personal Communications*, 42(3), 445-464.
- Anagnostopoulos, T., Anagnostopoulos, C., Hadjiefthymiades, S., Kyriakakos, M., & Kalousis, A. (2009). *Predicting the location of mobile users: a machine learning approach*. Paper presented at the Proceedings of the 2009 international conference on Pervasive services.
- Arlot, S., & Celisse, A. (2010). A survey of cross-validation procedures for model selection. *Statistics surveys*, 4, 40-79.
- Aswani, A., Master, N., Taneja, J., Culler, D., & Tomlin, C. (2012). Reducing transient and steady state electricity consumption in HVAC using learning-based model-predictive control. *Proceedings of the IEEE*, 100(1), 240-253.
- Ayodele, T. O. (2010). Types of machine learning algorithms *New advances in machine learning: InTech*.
- Babakura, A., Sulaiman, M. N., Mustapha, N., & Kasmiran, K. A. (2014). Comparison of Hidden Markov Model and Naïve Bayes Algorithms among Events in Smart Home Environment.

## References

- Behl, D., Handa, S., & Arora, A. (2014). *A bug mining tool to identify and analyze security bugs using naive bayes and tf-idf*. Paper presented at the Optimization, Reliability, and Information Technology (ICROIT), 2014 International Conference on.
- Bellavista, P., Corradi, A., Fanelli, M., & Foschini, L. (2012). A survey of context data distribution for mobile ubiquitous systems. *ACM Computing Surveys (CSUR)*, 44(4), 24.
- Bensi, M. T. (2010). A Bayesian network methodology for infrastructure seismic risk assessment and decision support.
- Bieber, G., Luthardt, A., Peter, C., & Urban, B. (2011). *The hearing trousers pocket: activity recognition by alternative sensors*. Paper presented at the Proceedings of the 4th International Conference on Pervasive Technologies Related to Assistive Environments.
- Bin Abdullah, M. F. A., Negara, A. F. P., Sayeed, M. S., Choi, D.-J., & Muthu, K. S. (2012). Classification algorithms in human activity recognition using smartphones. *International Journal of Computer and Information Engineering*, 6, 77-84.
- Bouckaert, R. R., Frank, E., Hall, M. A., Holmes, G., Pfahringer, B., Reutemann, P., & Witten, I. H. (2010). WEKA—Experiences with a Java Open-Source Project. *Journal of Machine Learning Research*, 11(Sep), 2533-2541.
- Bourobou, S. T. M., & Yoo, Y. (2015). User activity recognition in smart homes using pattern clustering applied to temporal ANN algorithm. *Sensors*, 15(5), 11953-11971.
- Brand, M., Oliver, N., & Pentland, A. (1997). *Coupled hidden Markov models for complex action recognition*. Paper presented at the Computer vision and pattern recognition, 1997. proceedings., 1997 IEEE Computer Society Conference on.
- Brezmes, T., Gorricho, J.-L., & Cotrina, J. (2009). Activity recognition from accelerometer data on a mobile phone. *Distributed computing, artificial intelligence, bioinformatics, soft computing, and ambient assisted living*, 796-799.
- Brown, B. A. M. a. S. J. (2006). Developing a well-being monitoring system—Modeling and data analysis techniques. *Elsevier*, 10.
- Buchanan, B. G., & Shortliffe, E. H. (1984). *Rule-based expert systems* (Vol. 3): Addison-Wesley Reading, MA.
- Carreira, P., Resendes, S., & Santos, A. C. (2014). Towards automatic conflict detection in home and building automation systems. *Pervasive and Mobile Computing*, 12, 37-57.
- Carreras, A., Delgado, J., Rodriguez, E., Barbosa, V., Andrade, M., Arachchi, H. K., . . . Kondo, A. (2010). A platform for context-aware and digital rights management-enabled content adaptation. *IEEE MultiMedia*, 17(2), 74-89.

## References

- Castilla, M., Álvarez, J., Berenguel, M., Rodríguez, F., Guzmán, J., & Pérez, M. (2011). A comparison of thermal comfort predictive control strategies. *Energy and buildings*, 43(10), 2737-2746.
- Castillejo, E., Almeida, A., López-de-Ipina, D., & Chen, L. (2014). Modeling users, context and devices for ambient assisted living environments. *Sensors*, 14(3), 5354-5391.
- Chahuara, P., Portet, F., & Vacher, M. (2012). *Context aware decision system in a smart home: knowledge representation and decision making using uncertain contextual information*. Paper presented at the The 4th International Workshop on Acquisition, Representation and Reasoning with Contextualized Knowledge (ARCOE-12).
- Chahuara, P., Portet, F., & Vacher, M. (2013). Making context aware decision from uncertain information in a smart home: A markov logic network approach *Ambient Intelligence* (pp. 78-93): Springer.
- Chan, M., Campo, E., Estève, D., & Fourniols, J.-Y. (2009). Smart homes—current features and future perspectives. *Maturitas*, 64(2), 90-97.
- Charlon, Y., Bourennane, W., Bettahar, F., & Campo, E. (2013). Activity monitoring system for elderly in a context of smart home. *IRBM*, 34(1), 60-63.
- Cheek, P., Nikpour, L., & Nowlin, H. D. (2005). Aging well with smart technology. *Nursing administration quarterly*, 29(4), 329-338.
- Chen, C., Das, B., & Cook, D. J. (2010). *Energy prediction based on resident's activity*. Paper presented at the Proceedings of the International workshop on Knowledge Discovery from Sensor Data.
- Chen, G., & Kotz, D. (2000). A survey of context-aware mobile computing research: Technical Report TR2000-381, Dept. of Computer Science, Dartmouth College.
- Chen, H., Han, D., Dai, Y., & Zhao, L. (2015). Design of automatic extraction algorithm of knowledge points for MOOCs. *Computational intelligence and neuroscience*, 2015, 2.
- Chen, J., Wu, W., Guo, H., & Wang, W. (2012). *Context-aware Search for Personal Information Management Systems*. Paper presented at the SDM.
- Chen, P., & Zhi, X.-l. (2011a). Smart home architecture based on event-driven DPWS. *Journal of Shanghai University (English Edition)*, 15(5), 386-390.
- Chen, P., & Zhi, X.-l. (2011b). Smart home architecture based on event-driven DPWS. *Journal of Shanghai University (English Edition)*, 15, 386-390.

## References

- Chen, Z.-Y., Wu, C.-L., & Fu, L.-C. (2006). *Using semi-supervised learning to build bayesian network for personal preference modeling in home environment*. Paper presented at the 2006 IEEE International Conference on Systems, Man and Cybernetics.
- Cheng, B.-C., Tsai, Y.-A., Liao, G.-T., & Byeon, E.-S. (2010). HMM machine learning and inference for activities of daily living recognition. *The Journal of Supercomputing*, 54(1), 29-42.
- Cheng, S.-T., Wang, C.-H., & Horng, G.-J. (2012). OSGi-based smart home architecture for heterogeneous network. *Expert Systems with Applications*, 39(16), 12418-12429.
- Chernbumroong, S., Atkins, A. S., & Yu, H. (2011). *Activity classification using a single wrist-worn accelerometer*. Paper presented at the Software, Knowledge Information, Industrial Management and Applications (SKIMA), 2011 5th International Conference on.
- Choi, D., Kim, N., & Hung, D. T. (2012). Conceptual data modeling for realizing context-aware services. *Expert Systems with Applications*, 39(3), 3022-3030.
- Choi, J., Shin, D., & Shin, D. (2005). Research and implementation of the context-aware middleware for controlling home appliances. *IEEE Transactions on Consumer Electronics*, 51(1), 301-306.
- Cigler, J., & Prívará, S. (2010). *Subspace identification and model predictive control for buildings*. Paper presented at the Control Automation Robotics & Vision (ICARCV), 2010 11th International Conference on.
- Cook, D. J., & Das, S. K. (2007). How smart are our environments? An updated look at the state of the art. *Pervasive and Mobile Computing*, 3(2), 53-73.
- Cook, D. J., Youngblood, M., Heierman III, E. O., Gopalratnam, K., Rao, S., Litvin, A., & Khawaja, F. (2003). *MavHome: An agent-based smart home*. Paper presented at the 2003 IEEE International Conference on Pervasive Computing and Communications (PerCom).
- Coppola, P., Della Mea, V., Di Gaspero, L., Menegon, D., Mischis, D., Mizzaro, S., . . . Vassena, L. (2010). The context-aware browser. *Intelligent Systems, IEEE*, 25(1), 38-47.
- Cortes, C., & Vapnik, V. (1995). Support-vector networks. *Machine Learning*, 20(3), 273-297.
- Courtney, K. L., Demeris, G., Rantz, M., & Skubic, M. (2008). Needing smart home technologies: the perspectives of older adults in continuing care retirement communities.
- Crandall, A. S., & Cook, D. (2008). Attributing events to individuals in multi-inhabitant environments.
- Crandall, A. S., & Cook, D. J. (2013). Behaviometrics for identifying smart home residents *Human Aspects in Ambient Intelligence* (pp. 55-71): Springer.



## References

- Crepaldi, M., Sanginario, A., Ros, P. M., Grosso, M., Sassone, A., Poncino, M., . . . Demarchi, D. (2015). Towards multi-domain and multi-physical electronic design. *IEEE Circuits and Systems Magazine*, 15(3), 18-43.
- Damopoulos, D., Menesidou, S. A., Kambourakis, G., Papadaki, M., Clarke, N., & Gritzalis, S. (2012). Evaluation of anomaly-based IDS for mobile devices using machine learning classifiers. *Security and Communication Networks*, 5(1), 3-14.
- Das, B., Seelye, A. M., Thomas, B. L., Cook, D. J., Holder, L. B., & Schmitter-Edgecombe, M. (2012). *Using smart phones for context-aware prompting in smart environments*. Paper presented at the Consumer Communications and Networking Conference (CCNC), 2012 IEEE.
- Das, S. R., Chita, S., Peterson, N., Shirazi, B., & Bhadkamkar, M. (2011). *Home automation and security for mobile devices*. Paper presented at the Pervasive Computing and Communications Workshops (PERCOM Workshops), 2011 IEEE International Conference on.
- Davidovic, B., & Labus, A. (2015). A smart home system based on sensor technology. *Facta Universitatis, Series: Electronics and Energetics*, 29(3), 451-460.
- Demiris, G., Skubic, M., Rantz, M., Keller, J., Aud, M., Hensel, B., & He, Z. (2006). Smart home sensors for the elderly: a model for participatory formative evaluation. *human-computer interaction*, 6, 7.
- Dey, A. K. (2001). Understanding and using context. *Personal and ubiquitous computing*, 5(1), 4-7.
- Ding, D., Cooper, R. A., Pasquina, P. F., & Fici-Pasquina, L. (2011). Sensor technology for smart homes. *Maturitas*, 69(2), 131-136.
- Dobre, C., Manea, F., & Cristea, V. (2011). *CAPIM: A context-aware platform using integrated mobile services*. Paper presented at the Intelligent Computer Communication and Processing (ICCP), 2011 IEEE International Conference on.
- Duan, Q., Miao, D., Zhang, H., & Zheng, J. (2007). Personalized web retrieval based on rough-fuzzy method. *Journal of Computational Information Systems*, 3(3), 1067-1074.
- Dunkels, A. (2009). *Efficient application integration in IP-based sensor networks*. Paper presented at the Proceedings of the First ACM Workshop on Embedded Sensing Systems for Energy-Efficiency in Buildings.
- Dunstan, K., & Thomson, N. (2006). Demographic aspects of New Zealand's ageing population. *Statistics New Zealand, Wellington*.

## References

- Economic, U. N. D. o. (2010). *World population ageing 2009* (Vol. 295): United Nations Publications.
- ElecFreaks. (2013). New product post43 - Infrared sensor and speed module. Retrieved 30 March, 2014, from <http://www.elecfreaks.com/4360.html>
- ElecFreaks. (2014a). Specification of DYP-ME003. Retrieved 30 March, 2014, from <http://elec Freaks.com/store/download/datasheet/sensor/DYP-ME003/Specification.pdf>
- ElecFreaks. (2014b). Ultrasonic ranging module hc-sr04. Retrieved 30 March, 2015, from [http://www.elec Freaks.com/estore/.../EF03085-HC-SR04\\_Ultrasonic\\_Module\\_User\\_Guide](http://www.elec Freaks.com/estore/.../EF03085-HC-SR04_Ultrasonic_Module_User_Guide)
- Elkan, C., Berenji, H., Chandrasekaran, B., De Silva, C., Attikiouzel, Y., Dubois, D., . . . Klir, G. (1994). The paradoxical success of fuzzy logic. *IEEE expert*, 9(4), 3-49.
- Emartee. (2013a). Arduino mini sound sensor. Retrieved 30 March, 2014, from [www.emartee.com/product/42148/Mini%20Sound%20Sensor%20%20Arduino%20Compatible](http://www.emartee.com/product/42148/Mini%20Sound%20Sensor%20%20Arduino%20Compatible)
- Emartee. (2013b). HR202 humidity sensor module. Retrieved 30 March, 2014, from [http://www.elecrow.com/sensors-c-111/environment-c-111\\_112/hr202-humiditysensor-module-p-674.html](http://www.elecrow.com/sensors-c-111/environment-c-111_112/hr202-humiditysensor-module-p-674.html)
- Espada, J. P., Crespo, R. G., Martínez, O. S., G-Bustelo, B. C. P., & Lovelle, J. M. C. (2012). Extensible architecture for context-aware mobile web applications. *Expert Systems with Applications*, 39(10), 9686-9694.
- EZX, W. (2011). WIFLY GSX.
- Fahad, L. G., Ali, A., & Rajarajan, M. (2015). Learning models for activity recognition in smart homes *Information Science and Applications* (pp. 819-826): Springer.
- Fahim, M., Siddiqi, M. H., Lee, S., & Lee, Y.-K. (2010). *A multi-strategy Bayesian model for sensor fusion in smart environments*. Paper presented at the Computer Sciences and Convergence Information Technology (ICCIT), 2010 5th International Conference on.
- Fawcett, T. (2006). An introduction to ROC analysis. *Pattern recognition letters*, 27(8), 861-874.
- Franklin, D., & Flaschbart, J. (1998). *All gadget and no representation makes jack a dull environment*. Paper presented at the Proceedings of the AAAI 1998 Spring Symposium on Intelligent Environments.
- Gaddam, A., Mukhopadhyay, S. C., & Gupta, G. S. (2011). *Trial & experimentation of a smart home monitoring system for elderly*. Paper presented at the Instrumentation and Measurement Technology Conference (I2MTC), 2011 IEEE.

## References

- Gaddam, A., Mukhopadhyay, S. C., & Sen Gupta, G. (2011). *Trial & experimentation of a smart home monitoring system for elderly*. Paper presented at the Instrumentation and Measurement Technology Conference (I2MTC), 2011 IEEE.
- Garg, B. (2013). Design and Development of Naive Bayes Classifier. *Circulation*, 701, 8888.
- Gellersen, H. W., Schmidt, A., & Beigl, M. (2002). Multi-sensor context-awareness in mobile devices and smart artifacts. *Mobile Networks and Applications*, 7(5), 341-351.
- Ghabar, O., & Lu, J. (2014). The Designing and Implementation of a Smart Home System with Wireless Sensor/Actuator and Smartphone: IARIA.
- Ghabar, O., & Lu, J. (2015). Remote Control and Monitoring of Smart Home Facilities via Smartphone with Wi-Fly: IARIA.
- Gilks, W. R., Thomas, A., & Spiegelhalter, D. J. (1994). A language and program for complex Bayesian modelling. *The Statistician*, 169-177.
- Goossen, F., IJntema, W., Frasinca, F., Hogenboom, F., & Kaymak, U. (2011). *News personalization using the CF-IDF semantic recommender*. Paper presented at the Proceedings of the International Conference on Web Intelligence, Mining and Semantics.
- Goswami, A., Bezboruah, T., & Sarma, K. (2009). Design of an embedded system for monitoring and controlling temperature and light. *International Journal of Electronic Engineering Research*, 1(1), 27-36.
- Group, W. M. (2007). The waikato environment for knowledge analysis., The University of Waikato.
- Gu, T., Chen, S., Tao, X., & Lu, J. (2010). An unsupervised approach to activity recognition and segmentation based on object-use fingerprints. *Data & Knowledge Engineering*, 69(6), 533-544.
- Guinness, R. E. (2015). Beyond where to how: a machine learning approach for sensing mobility contexts using smartphone sensors. *Sensors*, 15(5), 9962-9985.
- Györfbiró, N., Fábrián, Á., & Hományi, G. (2009). An activity recognition system for mobile phones. *Mobile Networks and Applications*, 14(1), 82-91.
- Hall, M., Frank, E., Holmes, G., Pfahringer, B., Reutemann, P., & Witten, I. H. (2009). The WEKA data mining software: an update. *ACM SIGKDD explorations newsletter*, 11(1), 10-18.
- Han, T., Han, B., Zhang, L., Zhang, X., & Yang, D. (2012, 2012). *Coexistence study for WiFi and ZigBee under smart home scenarios*.
- Hand, D. J., & Yu, K. (2001). Idiot's Bayes—not so stupid after all? *International statistical review*, 69(3), 385-398.

## References

- Heinz, E. A., Kunze, K. S., Gruber, M., Bannach, D., & Lukowicz, P. (2006). *Using wearable sensors for real-time recognition tasks in games of martial arts-an initial experiment*. Paper presented at the Computational Intelligence and Games, 2006 IEEE Symposium on.
- Henricksen, K. (2003). *A framework for context-aware pervasive computing applications*: University of Queensland Queensland.
- Herrera, L., Mink, B., & Sukittanon, S. (2010). *Integrated personal mobile devices to wireless weather sensing network*. Paper presented at the Proceedings of the IEEE SoutheastCon 2010 (SoutheastCon).
- Hoareau, C., & Satoh, I. (2009). Modeling and processing information for context-aware computing: A survey. *New Generation Computing*, 27(3), 177-196.
- Hong, S. Y. C. Q. L. (2011). Smart home based on wireless sensor-actuator networks.
- Horvitz, E. J., Breese, J. S., & Henrion, M. (1988). Decision theory in expert systems and artificial intelligence. *International journal of approximate reasoning*, 2(3), 247-302.
- Hull, R., Neaves, P., & Bedford-Roberts, J. (1997). *Towards situated computing*. Paper presented at the Wearable Computers, 1997. Digest of Papers., First International Symposium on.
- Inventado, P. S., Legaspi, R., Cabredo, R., Moriyama, K., Fukui, K.-i., Kurihara, S., & Numao, M. (2013). *Identification of Effective Learning Behaviors*. Paper presented at the International Conference on Artificial Intelligence in Education.
- Isinkaye, F., Folajimi, Y., & Ojokoh, B. (2015). Recommendation systems: Principles, methods and evaluation. *Egyptian Informatics Journal*, 16(3), 261-273.
- Jensen, F. V. (1996). *An introduction to Bayesian networks* (Vol. 210): UCL press London.
- Jimenez, M. J., & Madsen, H. (2008). Models for describing the thermal characteristics of building components. *Building and Environment*, 43(2), 152-162.
- Joachims, T. (1996). A Probabilistic Analysis of the Rocchio Algorithm with TFIDF for Text Categorization: DTIC Document.
- Kadouche, R., Chikhaoui, B., & Abdulrazak, B. (2010). User's behavior study for smart houses occupant prediction. *annals of telecommunications-Annales des télécommunications*, 65(9-10), 539-543.
- Kang, W., Shin, D., & Shin, D. (2010). *Detecting and predicting of abnormal behavior using hierarchical markov model in smart home network*. Paper presented at the Industrial Engineering and Engineering Management (IE&EM), 2010 IEEE 17Th International Conference.

## References

- Kao, Y.-W., & Yuan, S.-M. (2012). User-configurable semantic home automation. *Computer Standards & Interfaces*, 34(1), 171-188.
- Kapitanova, K., & Son, S. H. (2012). Machine learning basics. *Intelligent Sensor Networks: The Integration of Sensor Networks, Signal Processing and Machine Learning*, 13.
- Karantonis, D. M., Narayanan, M. R., Mathie, M., Lovell, N. H., & Celler, B. G. (2006). Implementation of a real-time human movement classifier using a triaxial accelerometer for ambulatory monitoring. *IEEE transactions on information technology in biomedicine*, 10(1), 156-167.
- Khan, W. Z., Xiang, Y., Aalsalem, M. Y., & Arshad, Q. (2013). Mobile phone sensing systems: a survey. *Communications Surveys & Tutorials, IEEE*, 15(1), 402-427.
- Kohavi, R. (1995). *A study of cross-validation and bootstrap for accuracy estimation and model selection*. Paper presented at the Ijcai.
- Könönen, V., & Mäntyjärvi, J. (2008). Decision making strategies for mobile collaborative context recognition.
- Kononenko, I. (1990). Comparison of inductive and naive Bayesian learning approaches to automatic knowledge acquisition. *Current Trends in Knowledge Acquisition*, 190-197.
- Krishna, R. P., & De, S. K. (2005). *Naive-Bayes Classification using Fuzzy Approach*. Paper presented at the Intelligent Sensing and Information Processing, 2005. ICISIP 2005. Third International Conference on.
- Krishnan, N. C., & Cook, D. J. (2014). Activity recognition on streaming sensor data. *Pervasive and Mobile Computing*, 10, 138-154.
- Kuantama, E., Setyawan, L., & Darma, J. (2012). *Early flood alerts using short message service (SMS)*. Paper presented at the System Engineering and Technology (ICSET), 2012 International Conference on.
- Kuechler, B., & Vaishnavi, V. (2008). On theory development in design science research: anatomy of a research project. *European Journal of Information Systems*, 17(5), 489-504.
- Kuhn, T. S., & Hawkins, D. (1963). The structure of scientific revolutions. *American Journal of Physics*, 31(7), 554-555.
- Kühnel, C., Westermann, T., Hemmert, F., Kratz, S., Müller, A., & Möller, S. (2011). I'm home: Defining and evaluating a gesture set for smart-home control. *International Journal of Human-Computer Studies*, 69(11), 693-704.
- Kurihara, S., Moriyama, K., & Numao, M. (2013). *Context-aware application prediction and recommendation in mobile devices*. Paper presented at the Web Intelligence (WI) and

## References

- Intelligent Agent Technologies (IAT), 2013 IEEE/WIC/ACM International Joint Conferences on.
- Lakatos, I. (1980). *The methodology of scientific research programmes: Volume 1: Philosophical papers* (Vol. 1): Cambridge university press.
- Langhammer, N., & Kays, R. (2011). *Evaluation of wireless smart metering technologies in realistic indoor channels*. Paper presented at the Wireless Communication Systems (ISWCS), 2011 8th International Symposium on.
- Larrañaga, P., & Moral, S. (2011). Probabilistic graphical models in artificial intelligence. *Applied soft computing, 11*(2), 1511-1528.
- Larson, S. C. (1931). The shrinkage of the coefficient of multiple correlation. *Journal of Educational Psychology, 22*(1), 45.
- Lê, Q., Nguyen, H. B., & Barnett, T. (2012). Smart homes for older people: Positive aging in a digital world. *Future internet, 4*(2), 607-617.
- Lee, J., Oh, S., & Jeon, M. (2007). *A new context-aware learning system for predicting services to users in ubiquitous environment*. Paper presented at the International Symposium on Ubiquitous VR.
- Lee, S.-H., & Chung, T.-C. (2004). *System architecture for context-aware home application*. Paper presented at the Software Technologies for Future Embedded and Ubiquitous Systems, 2004. Proceedings. Second IEEE Workshop on.
- Lee, S.-H., Yang, K.-M., & Cho, S.-B. (2015). Integrated modular Bayesian networks with selective inference for context-aware decision making. *Neurocomputing, 163*, 38-46.
- Lenzerini, M. (2002). *Data integration: A theoretical perspective*. Paper presented at the Proceedings of the twenty-first ACM SIGMOD-SIGACT-SIGART symposium on Principles of database systems.
- Li, M., & Lin, H.-J. (2015). Design and implementation of smart home control systems based on wireless sensor networks and power line communications. *IEEE Transactions on Industrial Electronics, 62*(7), 4430-4442.
- Li, S.-F. (2006a). *Wireless sensor actuator network for light monitoring and control application*. Paper presented at the CCNC 2006. 2006 3rd IEEE Consumer Communications and Networking Conference, 2006.
- Li, S.-F. (2006b). *Wireless sensor actuator network for light monitoring and control application*. Paper presented at the Consumer Communications and Networking Conference, 2006. CCNC 2006. 3rd IEEE.

## References

- Lim, B. Y., & Dey, A. K. (2010). *Toolkit to support intelligibility in context-aware applications*. Paper presented at the Proceedings of the 12th ACM international conference on Ubiquitous computing.
- Lombriser, C., Bharatula, N. B., Roggen, D., & Tröster, G. (2007). *On-body activity recognition in a dynamic sensor network*. Paper presented at the Proceedings of the ICST 2nd international conference on Body area networks.
- Mafrur, R., Khusumanegara, P., Bang, G. H., Lee, D. K., Nugraha, I. G. D., & Choi, D. (2015). Developing and Evaluating Mobile Sensing for Smart Home Control. *International Journal of Smart Home*, 9(3), 215-230.
- Majeed, B. A., & Brown, S. J. (2006). Developing a well-being monitoring system—Modeling and data analysis techniques. *Applied soft computing*, 6(4), 384-393.
- Makonin, S., Bartram, L., & Popowich, F. (2013). A smarter smart home: Case studies of ambient intelligence. *IEEE pervasive computing*, 12(1), 58-66.
- Makonin, S., & Popowich, F. (2014). Home Occupancy Agent: Occupancy and Sleep Detection. *GSTF Journal on Computing (JoC)*, 2(1).
- Makris, P., Skoutas, D. N., & Skianis, C. (2013). A survey on context-aware mobile and wireless networking: on networking and computing environments' integration. *IEEE Communications Surveys & Tutorials*, 15(1), 362-386.
- Malik, N., Mahmud, U., & Javed, Y. (2007). *Future challenges in context-aware computing*. Paper presented at the proceedings of the IADIS International Conference WWW/Internet.
- Mann, W. C. (2005). *Smart technology for aging, disability, and independence: The state of the science*: John Wiley & Sons.
- Mann, W. C., & Milton, B. R. (2005). Home automation and smart homes to support independence. *Smart technology for aging, disability, and independence: The state of the science*, 32-66.
- Martin, D. J. J. H. (2016). Naive Bayes and Sentiment Classification. In S. Russell & a. P. Norvig (Eds.), *Speech and Language Processing: An Introduction to Natural Language Processing, Computational Linguistics, and Speech Recognition* (pp. 934 pp): Virginia Teller.
- Martin, E., Shia, V., Yan, P., Kuryloski, P., Seto, E., Ekambaram, V., & Bajcsy, R. (2011). *Enhancing context awareness with activity recognition and radio fingerprinting*. Paper presented at the Semantic Computing (ICSC), 2011 Fifth IEEE International Conference on.
- Maurer, U., Smailagic, A., Siewiorek, D. P., & Deisher, M. (2006). *Activity recognition and monitoring using multiple sensors on different body positions*. Paper presented at the

## References

- Wearable and Implantable Body Sensor Networks, 2006. BSN 2006. International Workshop on.
- Maximintegrated. (2008). Programmable Resolution 1-Wire Digital Thermometer. Retrieved 01 July, 2013, from <http://datasheets.maximintegrated.com/en/ds/DS18B20.pdf>
- McCarthy, J., Minsky, M. L., Rochester, N., & Shannon, C. E. (2006). A proposal for the dartmouth summer research project on artificial intelligence, august 31, 1955. *AI Magazine*, 27(4), 12.
- Medjahed, H., Istrate, D., Boudy, J., Baldinger, J.-L., & Dorizzi, B. (2011). *A pervasive multi-sensor data fusion for smart home healthcare monitoring*. Paper presented at the Fuzzy Systems (FUZZ), 2011 IEEE International Conference on.
- Melenhorst, A.-S., Fisk, A. D., Mynatt, E. D., & Rogers, W. A. (2004). *Potential intrusiveness of aware home technology: Perceptions of older adults*. Paper presented at the Proceedings of the Human Factors and Ergonomics Society Annual Meeting.
- Meng, Z., & Lu, J. (2015). A Rule-based Service Customization Strategy for Smart Home Context-aware Automation.
- Mitchell., T. M. (2015). Generative and discriminative classifiers: naive Bayes and logistic regression. *Manuscript available at <http://www.cs.cm.edu/~tom/NewChapters.html>* 17.
- Mohammad, R. M., Thabtah, F., & McCluskey, L. (2014). Intelligent rule-based phishing websites classification. *IET Information Security*, 8(3), 153-160.
- Mosteller, F., & Tukey, J. W. (1968). Data analysis, including statistics. *Handbook of social psychology*, 2, 80-203.
- Mrad, A. B., Delcroix, V., Piechowiak, S., Leicester, P., & Abid, M. (2015). An explication of uncertain evidence in Bayesian networks: likelihood evidence and probabilistic evidence. *Applied Intelligence*, 43(4), 802-824.
- Mukhopadhyay, S. C. (2015). Wearable sensors for human activity monitoring: A review. *IEEE sensors journal*, 15(3), 1321-1330.
- Neil, M., Fenton, N., & Nielson, L. (2000). Building large-scale Bayesian networks. *The Knowledge Engineering Review*, 15(03), 257-284.
- Network, R. (2011). WiFly Serial Adapter. Retrieved 01 March, 2016, from <https://www.google.co.uk/search?q=Roving+Network%2C+Wifly+serial+adapter-user+manual&oq=Roving+Network%2C+W>
- Networks, R. (2010). WiFly Serial Adapter RN-370 & RN-374. *Install Guide and User Manual*, 1.00, pp.1-21. [www.rovingnetworks.com](http://www.rovingnetworks.com)



## References

- Ni, Q., García Hernando, A. B., & de la Cruz, I. P. (2015). The elderly's independent living in smart homes: A characterization of activities and sensing infrastructure survey to facilitate services development. *Sensors, 15*(5), 11312-11362.
- Nichols, J., & Myers, B. A. (2006). Controlling home and office appliances with smart phones. *Pervasive Computing, IEEE, 5*(3), 60-67.
- Nogralles, H. A. H., Agbay, C. P. D., Flores, I. S. L., Manuel, A. L., & Salonga, J. B. C. (2014). *Low cost Internet based wireless sensor network for air pollution monitoring using Zigbee module*. Paper presented at the Digital Information and Communication Technology and its Applications (DICTAP), 2014 Fourth International Conference on.
- Oeppen, J., & Vaupel, J. W. (2002). Broken limits to life expectancy. *Science, 296*(5570), 1029-1031.
- Olanrewaju, O., & Jimoh, A. (2014). Review of energy models to the development of an efficient industrial energy model. *Renewable and Sustainable Energy Reviews, 30*, 661-671.
- Palmes, P., Pung, H. K., Gu, T., Xue, W., & Chen, S. (2010). Object relevance weight pattern mining for activity recognition and segmentation. *Pervasive and Mobile Computing, 6*(1), 43-57.
- Park, H.-S., & Cho, S.-B. (2012). A modular design of Bayesian networks using expert knowledge: Context-aware home service robot. *Expert Systems with Applications, 39*(3), 2629-2642.
- Pearl, J. (2014). *Probabilistic reasoning in intelligent systems: networks of plausible inference*: Morgan Kaufmann.
- Poitras, G. (2013). Richard Price, miracles and the origins of Bayesian decision theory. *The European Journal of the History of Economic Thought, 20*(1), 29-57.
- Pololu. (2013). Flammable gas & smoke sensor. Retrieved 30 March, 2014, from <http://www.pololu.com/product/1480>
- Ponciano, R., Pais, S., & Casal, J. (2015). Using accuracy analysis to find the best classifier for Intelligent Personal Assistants. *Procedia Computer Science, 52*, 310-317.
- Pourret, O., Naïm, P., & Marcot, B. (2008). *Bayesian networks: a practical guide to applications* (Vol. 73): John Wiley & Sons.
- Poveda Villalon, M., Suárez-Figueroa, M. C., García-Castro, R., & Gómez-Pérez, A. (2010). A context ontology for mobile environments.
- Privara, S., Široký, J., Ferkl, L., & Cigler, J. (2011). Model predictive control of a building heating system: The first experience. *Energy and buildings, 43*(2), 564-572.

## References

- Pung, H. K., Gu, T., Xue, W., Palmes, P. P., Zhu, J., Ng, W. L., . . . Chung, N. H. (2009). Context-aware middleware for pervasive elderly homecare. *IEEE Journal on Selected Areas in Communications*, 27(4), 510-524.
- Rabiner, L. R. (1989). A tutorial on hidden Markov models and selected applications in speech recognition. *Proceedings of the IEEE*, 77(2), 257-286.
- Ramparany, F., Benazzouz, Y., Gadeyne, J., & Beaune, P. (2011). Automated context learning in ubiquitous computing environments. *SEMANTIC SENSOR NETWORKS*, 1.
- Reed, J. W., Jiao, Y., Potok, T. E., Klump, B. A., Elmore, M. T., & Hurson, A. R. (2006). *TF-ICF: A new term weighting scheme for clustering dynamic data streams*. Paper presented at the Machine Learning and Applications, 2006. ICMLA'06. 5th International Conference on.
- Robles, R. J., & Kim, T.-h. (2010). Applications, systems and methods in smart home technology: a review.
- Rodgers, J., Bartram, L., & Woodbury, R. (2011). Challenges in sustainable human-home interaction. *XRDS: Crossroads, The ACM Magazine for Students*, 17(4), 42-46.
- Rohm. (2010). Digital 16bit sensor output type ambient light sensor IC. Retrieved 30 March,2014, from <http://www.elehouse.com/elehouse/images/product/Digital%20light%20Sensor/bh1750f vie. pdf>
- Roul, R. K., Devanand, O. R., & Sahay, S. K. (2014). Web document clustering and ranking using tf-idf based apriori approach. *arXiv preprint arXiv:1406.5617*.
- Saeedi, S., Moussa, A., & El-Sheimy, N. (2014). Context-aware personal navigation using embedded sensor fusion in smartphones. *Sensors*, 14(4), 5742-5767.
- Saizmaa, T., & Kim, H.-C. (2008). *Smart home design: Home or house?* Paper presented at the Convergence and Hybrid Information Technology, 2008. ICCIT'08. Third International Conference on.
- Sanchez, A., & Tercero, R. (2010). *Smart Home Technologies: Uses and Abuses*. Paper presented at the Artificial Intelligence (MICAI), 2010 Ninth Mexican International Conference.
- Santos, R., de Sousa, E., da Silva, F., da Cruz, S., & Fileti, A. (2013). *Real-Time Monitoring of Gas Pipeline through Artificial Neural Networks*. Paper presented at the 2013 BRICS Congress on Computational Intelligence and 11th Brazilian Congress on Computational Intelligence.
- Saponas, T., Lester, J., Froehlich, J., Fogarty, J., & Landay, J. (2008). ilearn on the iphone: Real-time human activity classification on commodity mobile phones. *University of Washington CSE Tech Report UW-CSE-08-04-02*, 2008.

## References

- Sashima, A., Inoue, Y., Ikeda, T., Yamashita, T., & Kurumatani, K. (2008). *CONSORTS-S: A mobile sensing platform for context-aware services*. Paper presented at the Intelligent Sensors, Sensor Networks and Information Processing, 2008. ISSNIP 2008. International Conference on.
- Schilit, W. N. (1995). *A system architecture for context-aware mobile computing*. Columbia University.
- Schneider-Fontan, M., & Mataric, M. J. (1998). Territorial multi-robot task division. *IEEE Transactions on Robotics and Automation*, 14(5), 815-822.
- Schneider, J. (1997). Cross validation. *A Locally Weighted Learning Tutorial Using Vizier*, 1.
- Shahi, A., Sulaiman, M. N., Mustapha, N., & Perumal, T. (2015). Naive Bayesian decision model for the interoperability of heterogeneous systems in an intelligent building environment. *Automation in Construction*, 54, 83-92.
- Soar, J., & Croll, P. R. (2007). Assistive technologies for the frail elderly, chronic illness sufferers and people with disabilities—a case study of the development of a smart home.
- Song, I.-J., & Cho, S.-B. (2013). Bayesian and behavior networks for context-adaptive user interface in a ubiquitous home environment. *Expert Systems with Applications*, 40(5), 1827-1838.
- Sposaro, F., & Tyson, G. (2009). *iFall: an Android application for fall monitoring and response*. Paper presented at the 2009 Annual International Conference of the IEEE Engineering in Medicine and Biology Society.
- Sriskanathan, N., Tan, F., & Karande, A. (2002). Bluetooth based home automation system. *Microprocessors and microsystems*, 26(6), 281-289.
- Stankovski, V., & Trnkoczy, J. (2006). Application of decision trees to smart homes *Designing smart homes* (pp. 132-145): Springer.
- STC MCU, L. (2011). STC89Cxx. STC89LExx Series MCU Data Sheet., *Data Sheet*.
- Strassner, J., & O'Sullivan, D. (2009). *Knowledge management for context-aware, policy-based ubiquitous computing systems*. Paper presented at the Proceedings of the 6th international workshop on Managing ubiquitous communications and services.
- Suryadevara, N., Mukhopadhyay, S., Rayudu, R., & Huang, Y. (2012). *Sensor data fusion to determine wellness of an elderly in intelligent home monitoring environment*. Paper presented at the Instrumentation and Measurement Technology Conference (I2MTC), 2012 IEEE International.

## References

- Tajika, Y., Saito, T., Teramoto, K., Oosaka, N., & Isshiki, M. (2003). Networked home appliance system using Bluetooth technology integrating appliance control/monitoring with Internet service. *Consumer Electronics, IEEE Transactions on*, 49(4), 1043-1048.
- Tapia, E. M., Intille, S. S., Haskell, W., Larson, K., Wright, J., King, A., & Friedman, R. (2007). *Real-time recognition of physical activities and their intensities using wireless accelerometers and a heart rate monitor*. Paper presented at the Wearable Computers, 2007 11th IEEE International Symposium on.
- Tapia, E. M., Intille, S. S., & Larson, K. (2004). *Activity recognition in the home using simple and ubiquitous sensors*. Paper presented at the Pervasive Technologies, C. ( 2012). Ultrasonic Ranging Module HC-SR04. *User's Manual, v1.0*, 7.
- Teranishi, T. (2007). Tear Term Version 2.3. Retrieved February, 2013, from <http://logmett.com/index.php?/products/teraterm.html>
- Teymourzadeh, R., Ahmed, S. A., Chan, K. W., & Hoong, M. V. (2013). *Smart gsm based home automation system*. Paper presented at the Systems, Process & Control (ICSPC), 2013 IEEE Conference on.
- Thomas, B. L., & Cook, D. J. (2016). Activity-Aware Energy-Efficient Automation of Smart Buildings. *Energies*, 9(8), 624.
- Trappeniers, L., Feki, M. A., Kawsar, F., & Boussard, M. (2013). The internet of things: the next technological revolution. *Computer*, 46(2), 0024-0025.
- Trstenjak, B., Mikac, S., & Donko, D. (2014). KNN with TF-IDF based Framework for Text Categorization. *Procedia Engineering*, 69, 1356-1364.
- Ueda, K., Suwa, H., Arakawa, Y., & Yasumoto, K. (2015). *Exploring accuracy-cost tradeoff in in-home living activity recognition based on power consumptions and user positions*. Paper presented at the Computer and Information Technology; Ubiquitous Computing and Communications; Dependable, Autonomic and Secure Computing; Pervasive Intelligence and Computing (CIT/IUCC/DASC/PICOM), 2015 IEEE International Conference on.
- Van Hoof, J., Kort, H., Rutten, P., & Duijnste, M. (2011). Ageing-in-place with the use of ambient intelligence technology: Perspectives of older users. *International journal of medical informatics*, 80(5), 310-331.
- Van Kasteren, T., Englebienne, G., & Kröse, B. J. (2010). An activity monitoring system for elderly care using generative and discriminative models. *Personal and ubiquitous computing*, 14(6), 489-498.

## References

- Van Nguyen, T., Woo, Y. C., & Choi, D. (2009). *CCBR: Chaining case based reasoning in context-aware smart home*. Paper presented at the Intelligent Information and Database Systems, 2009. ACIIDS 2009. First Asian Conference on.
- Vasilis, V. (2015). *Machine Learning Tutorial: The Naive Bayes Text Classifier*.
- Vazirgiannis, C. D. N. L. M. (2006). *A System Architecture for Context-Aware Service Discovery*. Elsevier.
- Von Alan, R. H., March, S. T., Park, J., & Ram, S. (2004). Design science in information systems research. *MIS quarterly*, 28(1), 75-105.
- Wang, X., Rosenblum, D., & Wang, Y. (2012). *Context-aware mobile music recommendation for daily activities*. Paper presented at the Proceedings of the 20th ACM international conference on Multimedia.
- Wazir Zada Khan, Y. X., Aalsalem, M. Y., & Arshad, Q. (2013). Mobile phone sensing systems: A survey. *IEEE Communications Surveys Tutorials*, 15(1), 402-427.
- Weiser, M. (1991). The computer for the 21st century. *Scientific american*, 265(3), 94-104.
- Whittaker, J. (2009). *Graphical models in applied multivariate statistics*: Wiley Publishing.
- Wolpert, D. M., & Ghahramani, Z. (2005). Bayes rule in perception, action and cognition. *Oxford companion to consciousness*.
- Wu, H. C., Luk, R. W. P., Wong, K. F., & Kwok, K. L. (2008). Interpreting tf-idf term weights as making relevance decisions. *ACM Transactions on Information Systems (TOIS)*, 26(3), 13.
- Wu, Q., Bell, D., & McGinnity, M. (2005). Multiknowledge for decision making. *Knowledge and information systems*, 7(2), 246-266.
- Xia, F., Tian, Y.-C., Li, Y., & Sung, Y. (2007). Wireless sensor/actuator network design for mobile control applications. *Sensors*, 7(10), 2157-2173.
- Xiao, J., & Boutaba, R. (2013). The design and implementation of an energy-smart home in Korea. *Journal of Computing Science and Engineering*, 7(3), 204-210.
- Xu, Y. (2007). *Textual CBR system using domain specific ontology*. (Maste Thesis).
- Yan, S., Qiang, C., & Hong, L. (2011). Smart Home Based on Wireless Sensor-Actuator Networks. *中国通信*, 8(1), 102-109.
- Yap, G.-E., Tan, A.-H., & Pang, H.-H. (2007). Discovering and exploiting causal dependencies for robust mobile context-aware recommenders. *IEEE Transactions on Knowledge and Data Engineering*, 19(7), 977-992.
- Yongli, G., Yin, O. S., & Han, P. Y. (2012). State of the art: a study on fall detection. *World Academy Science, Engineering and Technology*, 62, 294-298.

## References

- Zaidi, N. A., Cerquides, J., Carman, M. J., & Webb, G. I. (2013). Alleviating naive Bayes attribute independence assumption by attribute weighting. *The Journal of Machine Learning Research, 14*(1), 1947-1988.
- Zdziarski, J. (2009). *iPhone SDK Application Development: Building Applications for the AppStore*: " O'Reilly Media, Inc."
- ZENG, Z. (2012). Research on Context-aware Information Recommendation Service for the Ubiquitous Web. *Journal of Computational Information Systems (JCIS), 8*(9), 8.
- Zhang, J., Song, G., Wang, H., & Meng, T. (2011). Design of a wireless sensor network based monitoring system for home automation (pp. 57-60).
- Zhang, L., Leung, H., & Chan, K. C. (2008). Information fusion based smart home control system and its application. *IEEE Transactions on Consumer Electronics, 54*(3).
- Zhanguo, M., Jing, F., Liang, C., Xiangyi, H., & Yanqin, S. (2011). *An improved approach to terms weighting in text classification*. Paper presented at the Computer and Management (CAMAN), 2011 International Conference on.
- Zheng, Y., Mobasher, B., & Burke, R. (2014). *Context recommendation using multi-label classification*. Paper presented at the Web Intelligence (WI) and Intelligent Agent Technologies (IAT), 2014 IEEE/WIC/ACM International Joint Conferences on.
- Zwartjes, A., Havinga, P. J., Smit, G. J., & Hurink, J. L. (2012). Distribution Bottlenecks in Classification Algorithms. *Procedia Computer Science, 10*, 960-967

## Appendix A

### 1- Context Data Command Switching On/Off the Home Facilitates

<pre> #include &lt;reg52.h&gt; #include "string.h" sbit RELAYF1 = P1^0; sbit RELAYF2 = P1^1; sbit RELAYL1 = P1^2; sbit RELAYL2 = P1^3; sbit LED4 = P1^4; sbit LED5 = P1^5; sbit LED6 = P1^6; sbit LED7 = P1^7; unsigned char buffer[96]; unsigned int qmFlag=0; unsigned char UART_buff; unsigned char OnOff_Received='0'; void delay_nms(unsigned int m) {     unsigned int i,j;     for(i=0; i&lt;m; i++)         for(j=0; j&lt;100; j++); } void init232(void) {     SCON=0x50;// serial port control register     TMOD=0x20; // or 20 set timer1 as 8bit auto     reload mode     TH1=0xFA;// set auto-reload value     IE  =0x90; // interrupt permit register     PCON=0x80;// power control register     TR1=1; // timer1 start run     ET1=0;//timer1 interrupt will be disabled     ES=1;//enable UART interrupt     PS=1;     EA=1; } void send_charac_com(unsigned char char) {     SBUF=char;     while (TI== 0);     delay_nms(5000);     EA=0;     send_string_com("light");     EA=1; if(OnOff_Received =='0') RELAYF1 = 0x00; </pre>	<pre> TI=0; // clear TI flag ES=1; } void send_string_com (charact *string) {     While (string &amp;&amp; *string){         send_charact_com (*string++);     } } void main(void){     init232();     ES=1;     EA=1;     ET0=1;     TR0=1;     P1= 0xFF;     RELAYF1=0;     RELAYF2=0;     RELAYL1=0;     RELAYL2=0;     while(Vazirgiannis)     { if(OnOff_Received=='0') RELAYF1 = 0x00; if(OnOff_Received=='a') RELAYF1 = 0xFF; if(OnOff_Received=='1') RELAYF2 = 0x00; if(OnOff_Received=='b') RELAYF2 = 0xFF; if(OnOff_Received=='2') RELAYL1 = 0x00; if(OnOff_Received=='c') RELAYL1 = 0xFF; if(OnOff_Received=='3') RELAYL2 = 0x00; if(OnOff_Received=='d') RELAYL2 = 0xFF; if (OnOff_Received=='\$') { RELAYF1 = 0x00; RELAYF2 = 0x00; RELAYL1 = 0x00; RELAYL2 = 0x00; }if(OnOff_Received=='&amp;') { RELAYF1 = 0xFF; RELAYF2 = 0xFF; RELAYL1 = 0xFF; RELAYL2 = 0xFF; }  if(RI == 1){ RI=0; </pre>
--	--

## Appendix A

<pre> if(OnOff_Received == 'a') RELAYF1 = 0xFF; if(OnOff_Received == '1') RELAYF2 = 0x00; if(OnOff_Received == 'b') RELAYF2 = 0xFF; if(OnOff_Received == '2') RELAYL1 = 0x00; if(OnOff_Received == 'c') RELAYL1 = 0xFF; if(OnOff_Received == '3') RELAYL2 = 0x00; if(OnOff_Received == 'd') RELAYL2 = 0xFF; if (OnOff_Received == '\$') {     RELAYF1 = 0x00;     RELAYF2 = 0x00;     RELAYL1 = 0x00;     RELAYL2 = 0x00; } if(OnOff_Received == '&amp;') {     RELAYF1 = 0xFF;     RELAYF2 = 0xFF;     RELAYL1 = 0xFF;     RELAYL2 = 0xFF; } delay_nms(5000); EA=0; send_string_com("fan"); EA=1; }} void ser_int(void)interrupt 4 { </pre>	<pre> UART_buff = SBUF; // write to send characters if(UART_buff != '?') qmFlag=1; if((qmFlag== 1)&amp;&amp;(UART_buff != '?')){     OnOff_Received=UART_buff;     qmFlag=0; if (OnOff_Received == '0') RELAYF1 = 0x00; if (OnOff_Received == 'a') RELAYF1 = 0xFF if (OnOff_Received == '1') RELAYF2 = 0x00; if (OnOff_Received == 'b') RELAYF2 = 0xFF if (OnOff_Received == '4') LED4 = 0x00; if (OnOff_Received == 'e') LED4 = 0xFF if (OnOff_Received == '5') LED5 = 0x00; if (OnOff_Received == 'f') LED5 = 0xFF; if (OnOff_Received == '6') LED6 = 0x00; if (OnOff_Received == 'g') LED6 = 0xFF; if (OnOff_Received == '7') LED7 = 0x00; if (OnOff_Received == 'h') LED7 = 0xFF; if (OnOff_Received == '\$') P1 = 0x00; if (OnOff_Received == '&amp;') P1 = 0xFF; } } else     TI=0; //Clear to Send flag } </pre>
--	---

## 2- Context Data Collection and Monitoring

<pre> #include &lt;reg52.h&gt; #include "string.h" #include &lt;math.h&gt; #include &lt;stdio.h&gt; #define UnCharacter unsigned charact #define uint unsigned int #define SlaveAddress 0x46 sbit sensor1=P2^0; sbit sensor2=P2^1; sbit sensor3=P2^2; sbit sensor4=P2^3; sbit sensor5=P2^4; sbit SCL=P1^0; sbit SDA=P1^1; sbit DQ =P2^5; sbit echo=P2^6; </pre>	<pre> uchar i; for(i=11;i&gt;0;i--); } void Delay5ms() {     uint k;     for(k=0;k&lt;560;k++){;} } void Delay5us() {     uint k;     for(k=0;k&lt;16;k++){;} } void sDelay(int num) {     while(num--); } </pre>
---	---



## Appendix A

<pre> sbit trig=P2^7; unsigned dataSensor; unsigned char UART_buff; unsigned char buffer[64]; unsigned char tempt[8]; unsigned char temp[8]; unsigned char tempd[6]; unsigned int dis; unsigned char levelD[2]; char tempt_string[]; uchar BUF[8]; int dis_data; char mysqli[32]; int mysqlLocation =1; int mysqlDevice = 1; void delay_nms(uint k) {     uint i,j;     for(i=0;i&lt;k;i++)         for(j=0;j&lt;121;j++){;} } void delay10ns() { uint getDistance() {     uint i=29412;//65535;     TR0=0;     TH0=0;     TL0=0;     echo=0;     trig=1;     delay10ns();     trig=0;     while(!echo&amp;&amp; i&gt;0)     {         i--;     }     if(i&gt;0)     {         TR0=1;         while(Mrad et al.);         TR0=0;         return(uint)((TH0*256+TL0)*2.45)/100;     }     else         return 0; } </pre>	<pre> } void init() {     TMOD=0x01;     TR0=0;     ET0=1;     trig=0;     echo=0;     TH0=0;     TL0=0;     EA=0; } void Init_DS18B20(void) {     unsigned char x=0;     DQ=1;     sDelay(Vazirgiannis);     DQ=0;     sDelay(60);     DQ=1;     sDelay(Vazirgiannis);     x=DQ;     sDelay(15); }     DQ=0;     DQ=dat&amp;0x01;     sDelay(Vazirgiannis);     DQ=1;     dat&gt;&gt;=1; } } unsigned character * Read_Temperature(void) {     Write_One_character (0xCC);     Write_One_character (0x44);     unsigned character a=0;     unsigned character b=0;     unsigned character Data_L=0;     unsigned character num=0;     Init_DS18B20();     Write_One_character(0xCC);     Write_One_character(0xBE);     sDelay(500);     a=ReadOneChar();     b=ReadOneChar();     Data_L=a&amp;0x0F ; } </pre>
--	--

## Appendix A

<pre> } unsigned character Read_One_Character (void) {     unsigned character i=0;     unsigned character data =0;     for(i=8;i&gt;0;i--)     {         DQ=0;         data&gt;&gt;=1;         DQ=1;         if(DQ)             data =0x80;         sDelay(4);     }     return(data); } void Write_One_Character (unsigned character data) {     unsigned character j=0;     for(j=8;j&gt;0;j--){ void BH1750_Stop() {     SDA = 0;     SCL = 1;     Delay5us();     SDA = 1;     Delay5us(); } void BH1750_Send_ACKN(bit ackn) {     SDA = ackn;     SCL = 1;     Delay5us();     SCL = 0;     Delay5us(); } bit BH1750_Recv_ACKN() {     SCL = 1;     Delay50usecond();     SCL = 0;     YM = SDA;     Delay50usecond();     return YM; } void BH1750_SendByte(uchar dat) </pre>	<pre> tempt[0]=(a/16+b*16)/10+'0'; tempt[1]=(a/16+b*16)%10+'0'; tempt[2]=0x2E; tempt[3]=Data_L*10/16+'0'; tempt[4]=(Data_L*10%16)*10/16+'0'; tempt[5]='\0'; return tempt; } void BH1750_Start() {     SDA = 1;     SCL = 1;     Delay5us();     SDA = 0;     Delay5us();     SCL = 0; } uncharater j;     uncharacter data = 0;      SDA = 1;     for (j=0; j&lt;8; j++)     {         data &lt;&lt;= 1;         SCL = 1;         Delay50usecond();         data  = SDA;         SCL = 0;         Delay50usecond();     }     return dat; } void SingleWriteBH1750(ucharacter REG_Address) {     BH1750_Start();     BH1750_SendByte(SlaveAddress);     BH1750_SendByte(REG_Address);     BH1750_Stop(); } void Init_BH1750(void) {     Single_Write_BH1750(0x01); } void Multiple_Read_BH1750(void) {     uchar j; </pre>
---	--

## Appendix A

<pre> {   uchar j;   for (j=0; j&lt;8; j++)   {     data &lt;&lt;= 1;     SDA = CY;     SCL = 1;     Delay50usecond();     SCL = 0;     Delay50usecond();   }   BH1750_Recv_ACKN(); } uchar BH1750_RecvByte() { void Init232(void){   SCON = 0x50;   TMOD = 0x20;   TH1 = 0xFD;   TL1 = 0xFD;   TR1 = 1; } void conversion(uint temp_data) {   templ[0]=temp_data/10000+'0';   templ[1]=(temp_data%10000)/1000+'0';   templ[2]=(temp_data%1000)/100+'0';   templ[3]=(temp_data%100)/10+'0';   templ[4]=(temp_data%10)+'0';   //templ[5]=0x0A;   templ[5]='\0'; } float brightnessGet(){   float tempv;   Single_Write_BH1750(0x01);   Single_Write_BH1750(0x10);   delay_nms(180);   Multiple_Read_BH1750();   dis_data=BUF[0];   dis_data=(dis_data&lt;&lt;8)+BUF[1];   tempv=(float)dis_data/1.2;   return tempv; } void send_character_comm(unsigned char ch) {   SBUF=ch; </pre>	<pre> BH1750_Start(); BH1750_SendByte(SlaveAddress+1); for (j=0; j&lt;3; j++) {   BUF[j] = BH1750_RecvByte();   if (j == 3)     BH1750_Send_ACKN(Vazirgiannis);   else     BH1750_Send_ACKN(0); } BH1750_Stop(); Delay5ms();} {   TMOD  = 0x02;   TL0 = 0xF0;   TH0 = TL0;   ET0 = 1;   EA = 1;   TR0 = 1; } void dataConvert(uint dist){   tempd[0]=dist/1000+'0';   tempd[1]=(dist%1000)/100+'0';   tempd[2]=(dist%100)/10+'0';   //tempd[3]=(dist%10)/10+'0';   tempd[3]=dist%10+'0';   //tempd[5]=0x0A;   tempd[4]='\0'; } void main (void) {   float temp;   uint distance=0;   init();   Timer0_Init();   Init232();   Init_BH1750();   ES = 1;   EA = 1;   while(Vazirgiannis) {     dataSensor=0;     P2=0xFF; //NEW LINE FOR CHECK     sensor1=0x1;     sensor2=0x1;     sensor3=0x1;     sensor4=0x1; </pre>
--	--

## Appendix A

<pre> while (TI== 0); TI=0; ES=1; } void send_string_comm(character *string) { while(string &amp;&amp; *string){ send_character_comm(*string++); }} void Timer0_Init(void) mysqlLocation++; if(mysqlLocation &gt; 4    mysqlLocation == 6) { mysqlLocation = 1; } strcat(buffer,"A="); sprintf(mysqlcli, "%d", mysqlDevice); strcat(buffer,mysqlcli); strcat(buffer,"&amp;"); mysqlDevice++; if(mysqlDevice &gt; 2    mysqlDevice == 6) { mysqlDevice = 1; } strcat(buffer,"O="); if(dataSensor &amp;0x01)strcat(buffer,"Lo&amp;"); else strcat(buffer,"Ho&amp;"); strcat(buffer,"B="); if(dataSensor &amp;0x02)strcat(buffer,"Lb&amp;"); else strcat(buffer,"Hb&amp;"); strcat(buffer,"S="); if(dataSensor &amp;0x04)strcat(buffer,"Ls&amp;"); else strcat(buffer,"Hs&amp;"); strcat(buffer,"H="); if(dataSensor &amp;0x08)strcat(buffer,"Lh&amp;"); else strcat(buffer,"Hh&amp;"); strcat(buffer,"U="); if(dataSensor &amp;0x10)strcat(buffer,"Lu&amp;"); else strcat(buffer,"Hu&amp;"); temp=brightnessGet(); conversion(temp); </pre>	<pre> sensor5=0x1; dataSensor=0x1F; dataSensor = P2; strcpy(buffer,"RN="); sprintf(mysqlcli, "%d", mysqlLocation); strcat(buffer,mysqlcli); strcat(buffer,"&amp;"); ReadTemperature(); strcat(buffer,"T=");  //strcat(buffer, ReadTemperature()); strcat(buffer, tempt); strcat(buffer, "&amp;"); distance=getDistance(); dataConvert(distance); strcat(buffer,"D="); // strcat(buffer, readLevelD()); strcat(buffer, tempd); strcat(buffer,"&amp;");  send_string_com(buffer); delay_nms(5000); } } </pre>
---	---

## Appendix A

<pre>strcat(buffer,"L="); strcat(buffer,templ); strcat(buffer,"&amp;");</pre>	
---	--

### 3- Decision Making of the Maximum Probability

```
$resulttable['FF'] = (float) ($pactions['FF']*$scondprob['BdyA']*$scondprob['OstA']
*$scondprob['HmtA']*$scondprob['TmpA']*$scondprob['DstA']*$scondprob['locationA']) /
($probabilityHb['Hb']*$probabilityHo['Ho']*$probabilityHh['Hh']*$probabilityHt['Ht']
*$probabilityCd['Cd']*$probabilityLR['LR']);
echo "Probability of FF|(Lo,M,Lb,Lo,Hh,Ls,H,Cd,LR):". $resulttable['FF']. "<br><br>";
$resulttable ['FO'] = (float) ($pactions ['FO']*$scondprob ['OstA']*$scondprob ['HmtA']
*$scondprob ['TmpA']*$scondprob ['DstA']*$scondprob ['locationA']) / ($probabilityHb
['Hb']*$probabilityHo['Ho']*$probabilityHh['Hh']*$probabilityHt['Ht']*$probabilityCd['Cd']
*$probabilityLR ['LR']);
echo "Probability of FO|(Lu,Ml,Lb,Lo,Hh,Ls,Ht,Cd,LR):". $resulttable['FO']. "<br><br>";
$ mysqli_close ($conDB);
$ idstring = "FF";
$ idvalue = $resulttable [$ idstring];
if ($resulttable["WO"] > $resulttable[$ idstring])
{
    $ idstring = "WO";
    $ idvalue = $resulttable ["WO"];
    echo '&';
}
if ($resulttable["WF"] > $resulttable[$ idstring])
{
    $ idstring = "WF";
    $ idvalue = $resulttable ["WF"];
    echo '$';
}
if ($resulttable["FO"] > $resulttable[$ idstring])
{
    $ idstring = "FO";
    $ idvalue = $resulttable ["FO"];
    echo '&';
}
echo "Maximum Probability Action:
". $ idstring. "(Lu,Ml,Hb,Ho,Hh,Ls,Hh,Cd,LR):". $resulttable[$ idstring]. "<br>";
echo '$'
```

## Appendix A

- 4- Smartphone to remote control server: The HTTP requests (POST, SPLIT and SWITCH) are used as example request as following:

- **POST**

```
-(IBAction)postString:(id)sender{
    NSString *url=[NSString stringWithFormat:@"http://localhost/work2/allsensors.php"];
    NSString *postString = [NSString
stringWithFormat:@"lab2=% @&lab3=% @&lab4=% @&lab5=% @&lab6=% @&lab7=% @&lab8=
8=% @", lab2str, lab3str, lab4str, lab5str, lab6str, lab7str, lab8str];
    NSMutableURLRequest *request = [NSMutableURLRequest requestWithURL:[NSURL
URLWithString:url] cachePolicy:NSURLRequestUseProtocolCachePolicy timeoutInterval:60.0];
    [request setHTTPMethod:@"POST"];
    [request setHTTPBody:[postString dataUsingEncoding:NSUTF8StringEncoding]];
    postConnection =[[NSURLConnection alloc] initWithRequest:request delegate:self
startImmediately:YES];
}
```

- **SPLIT**

```
-(IBAction)stringSplit:(id)sender{
    NSString *resultString = [NSString string];
    NSString *texttosplit = textView.text;
    for(int currentCharacterIndex = 0; currentCharacterIndex < texttosplit.length;
currentCharacterIndex++) {
        unichar currentCharacter = [texttosplit characterAtIndex:currentCharacterIndex];
        BOOL isLessThan48 = resultString.length < 48;
        BOOL isNewLine = (currentCharacter == '\n');
        if(!isNewLine && isLessThan48) {
            resultString = [resultString stringByAppendingFormat:[NSString stringWithFormat:@"%C",
currentCharacter]];
        }
        else {
            break;
        }
    }
    NSArray *firstSplit = [texttosplit componentsSeparatedByString:@"&"];
    NSArray *ID = [firstSplit[0] componentsSeparatedByString:@"="];
    label0.text = ID[1];
    NSArray *RN = [firstSplit[1] componentsSeparatedByString:@"="];
    label1.text = RN[1];
    NSArray *O = [firstSplit[2] componentsSeparatedByString:@"="];
    label2.text = O[1];
    NSArray *B = [firstSplit[3] componentsSeparatedByString:@"="];
    label3.text = B[1];
    NSArray *S = [firstSplit[4] componentsSeparatedByString:@"="];
    label4.text = S[1];
    NSArray *H = [firstSplit[5] componentsSeparatedByString:@"="];
    label5.text = H[1];
    NSArray *U = [firstSplit[6] componentsSeparatedByString:@"="];
    label6.text = U[1];
    NSArray *L = [firstSplit[7] componentsSeparatedByString:@"="];
}
```

## Appendix A

```
label7.text = L[1];
NSArray *T = [firstSplit[8] componentsSeparatedByString:@"="];
label8.text = T[1];
NSArray *D = [firstSplit[9] componentsSeparatedByString:@"="];
label9.text = D[1];
```

- **SWITCH**

```
-(IBAction) switchLedLightValueChanged:(id)sender
{
    NSString *typecode;
    if (redViewController.switchLedLight.on)
        typecode = @"1";
    else
        typecode = @"A";
    const char *data = [typecode UTF8String];
    if (connected == YES)
        send(CFSocketGetNative(_socket), data, strlen(data) + 1, 0);
    else {
        UIAlertView *alert = [[UIAlertView alloc] initWithTitle:@"Network Error"
        message:@"Please Setup Your Adhoc First!" delegate: nil cancelButtonTitle:@"OK"
        otherButtonTitles: nil];
        [alert show];
        [alert release];
    }
}
```

## Appendix B

### Appendix B

Table Ab-1 Specification parameters of the sensors

Sensor	Module	Resolution	Power	Analog Output	Digital Output	Temperature	Dimension
<b>Obstacle avoidance sensor</b> <b>(ElecFreaks, 2013)</b>	E15-D50 NK	<10cm-60cm>	4.5V~5V DC	/	High '1' or low '0'	-25 °C ~ +55 °C	Diameter: 17MM Length: 45 MM
<b>Human body sensor</b> <b>(ElecFreaks, 2014a)</b>	DYP-ME003	< 7m	4.5V~5V DC	/	High '1' or low '0'	<-15 °C - +70 °C >	Diameter: 23mm
<b>Light sensor</b> <b>(Rohm, 2010)</b>	LM393	Adjustable	3.3V~5V	1-5V			3mm/0.12"
<b>Smoke sensor</b> <b>(Pololu, 2013)</b>	ZYM-Q-2	Adjustable	3V~5V	0-5V	High '1' or low '0'	-20 °C ~ +55 °C	Dimension: 32mm*22mm*27mm
<b>Humidity sensor</b> <b>(Emartee, 2013b)</b>	HR202 LM393	Adjustable	5V	0-5V	High '1' or low '0'	0°C to +60 °C	32mm x 11mm x 20mm
<b>Temperature sensor</b> <b>(Maximintegrated., 2008)</b>	DSI2B20	9~12 Adjustable	3V~5.5V	0-1V	Digital value	-55 °C ~ +125 °C	6*30mm*100cm
<b>Sound sensor</b> <b>(Emartee, 2013a)</b>	CZN-15E	Adjustable	3.3~5 V	/	High '1' or low '0'		3.4cm x 1.6cm
<b>Ultrasonic distance measurement sensor</b> <b>(ElecFreaks, 2014b)</b>	HC-SR04	2cm – 400cm	5 V	10uS cycle burst at 40 kHz	Output TTL level signal	0°C to +70 °C	45 x 20 x 1.6 mm





## Appendix B

Table Ab-2 Features of three types of STC89Cxx MCU (STC MCU, 2011)

Parameter	STC89C51RC	STC89C52RC	STC89C54RC
<b>Operating voltage</b>	3.3V~ 5.5V	3.3V~5.5V	3.3V~5.5V
<b>UART</b>	1	1	1
<b>DPRT</b>	2	2	2
<b>A/D</b>	NO	NO	NO
<b>WDT</b>	YES	YES	YES
<b>Internal low voltage interrupt</b>	YES	YES	YES
<b>Program flash memory</b>	4KB	8KB	16KB

Table Ab-3 shows the interface pins between Wi-Fly and MCU STC89C52RC

DB9 (WiFly -RN370)		Signal Direction	Microcontroller
Pin	Signal		Signal
2	TXD		RXD
3	RXD		TXD
5	GND		GND

## Appendix B

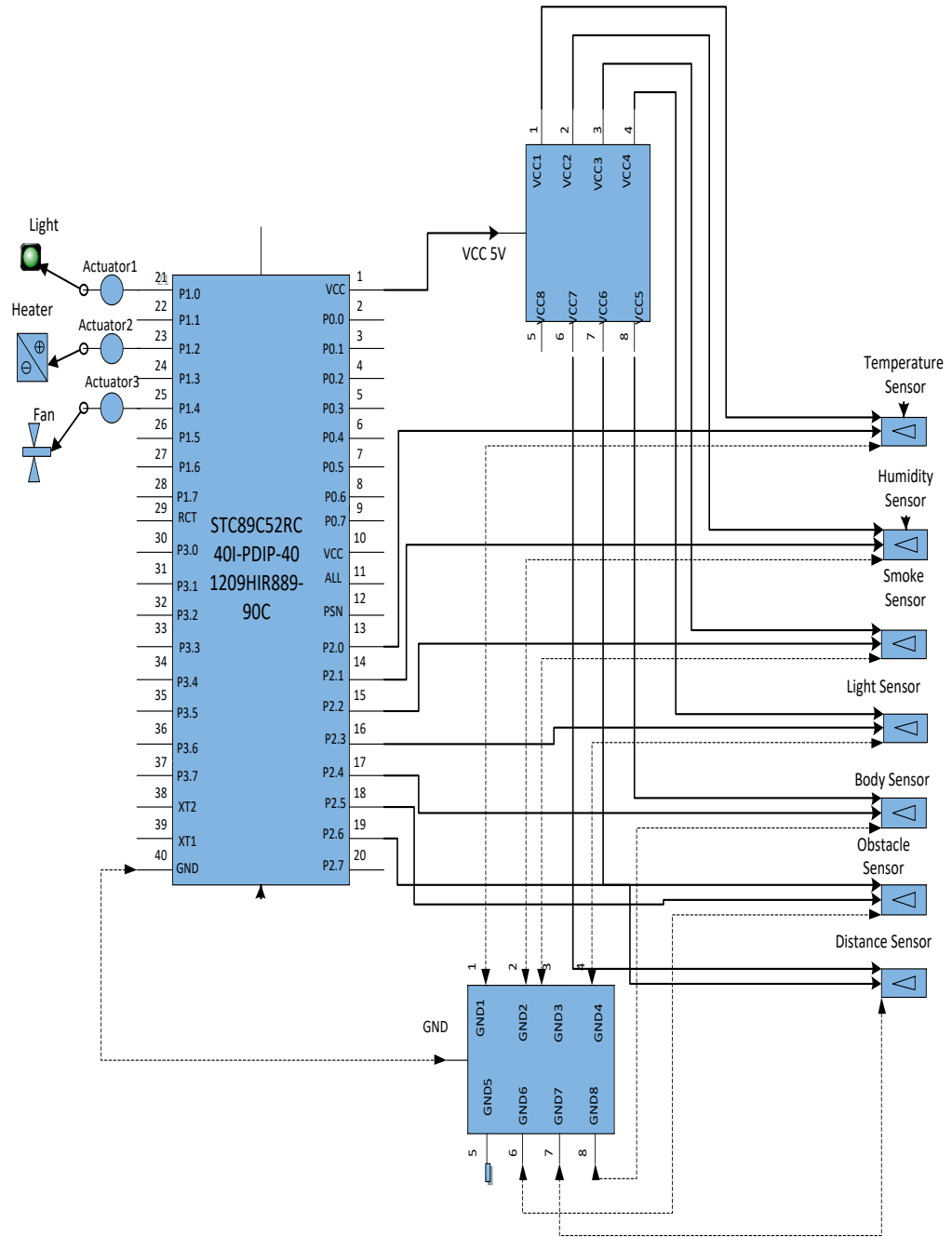

Figure Ab-1 Schematic for STC89C52RC and the connection of sensors

## Appendix B

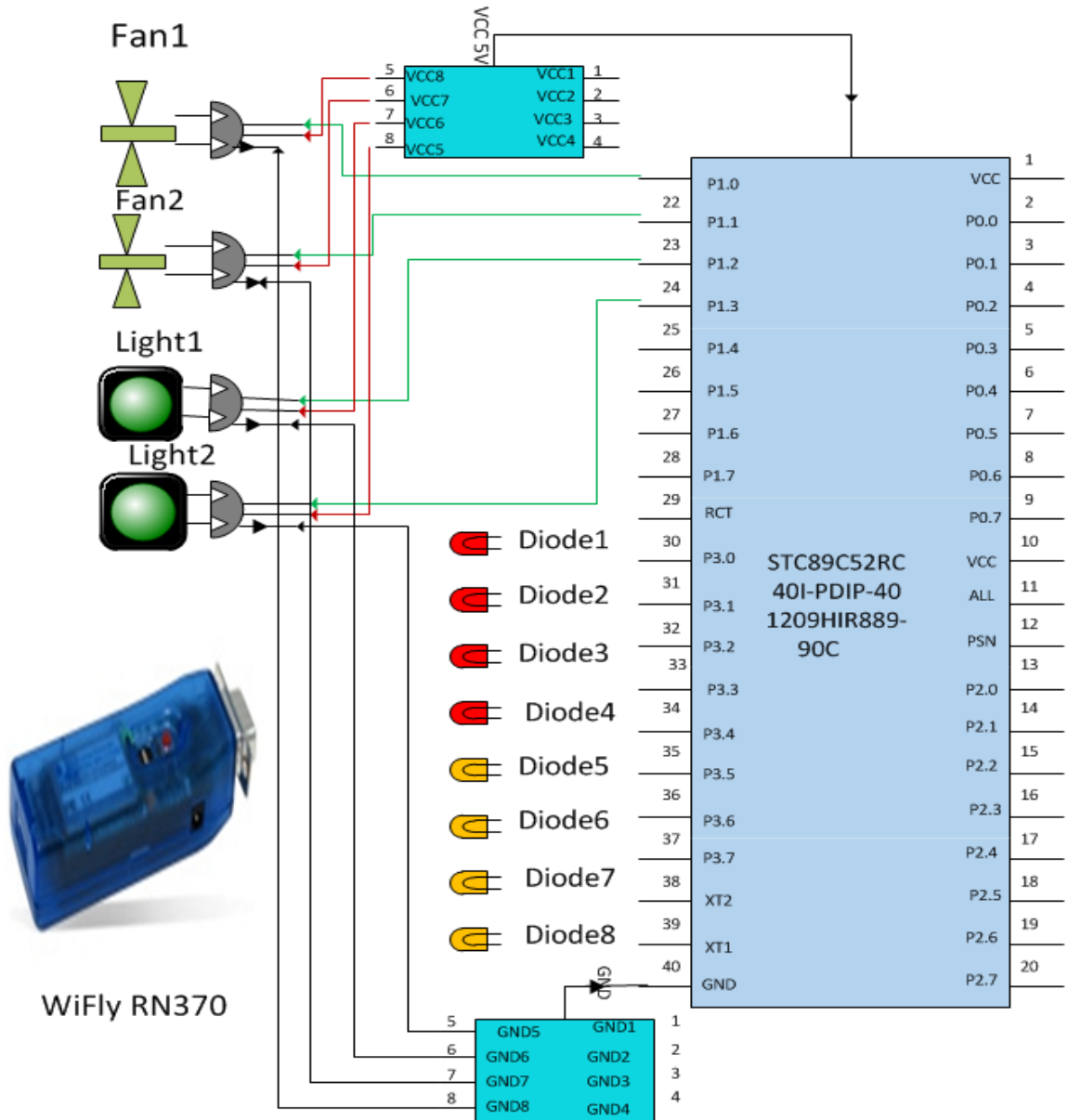

Figure Ab-2 Schematic for STC89C52RC and the connection of actuators and electrical devices

Appendix C

Appendix C

Table Ac-1 Search Engine Results (EF-ICF-IF)

ID	Terms	Total number	Total weight EF*ICF*IF	ICF	EF	IF	Total weight NB
	Total rows	330					
	Total pages	11					
1	Humidity high	330	1	1	1	1	1
1	Smoke low	330	1	1	1	1	1
2	sound low	329	0.9967711937 0263	1.001318041927 91	0.99848484848 4849	0.9969696969 69697	0.9969697
3	Temperature high	289	0.8686776915 9841	1.057616097121 34	0.93787878787 8788	0.8757575757 57576	0.8757576
4	Living Room	256	0.7647330604 61427	1.110273974566 04	0.88787878787 8788	0.7757575757 57576	0.7757576
5	distance close	255	0.7616101265 61289	1.111973759443 93	0.88636363636 3636	0.7727272727 27273	0.7727273
6	Obstacle high	254	0.7584888411 25764	1.113680223257 95	0.88484848484 8485	0.7696969696 9697	0.769697
7	Human Body high	251	0.7491349306 19977	1.118840218396 85	0.88030303030 303	0.7606060606 06061	0.7606061
8	Brightness low	134	0.3972096179 18812	1.391409141513 08	0.70303030303 0303	0.4060606060 60606	0.4060606
9	device fan ON	118	0.3511237395 93543	1.446631932571 76	0.67878787878 7879	0.3575757575 75758	0.3575758
10	Brightness high	110	0.3282491677 1548	1.477121254719 66	0.66666666666 6667	0.3333333333 33333	0.3333333
11	device window ON	108	0.3225468598 82593	1.485090184390 94	0.66363636363 6364	0.3272727272 72727	0.3272727
12	Brightness medium	86	0.2601916350 84396	1.584015488634 32	0.63030303030 303	0.2606060606 06061	0.2606061
13	Human Body low	79	0.2404613175 60647	1.620886848587 45	0.61969696969 697	0.2393939393 93939	0.2393939
14	Obstacle low	76	0.2320150685 28264	1.637700347597 1	0.61515151515 1515	0.2303030303 0303	0.230303
15	Living Bed Room	74	0.2263863234 78017	1.649282220146 91	0.61212121212 1212	0.2242424242 42424	0.2242424
16	Distance far	71	0.2179450593 934	1.667255591158 81	0.60757575757 5758	0.2151515151 51515	0.2151515
17	device window OFF	54	0.1700504502 0027	1.786120180054 92	0.58181818181 8182	0.1636363636 36364	0.1636364

### Appendix C

18	device fan OFF	50	0.1587297280 77574	1.819543935541 87	0.57575757575 7576	0.1515151515 15152	0.1515152
19	Temperature medium	41	0.1330948590 21665	1.905730083158 15	0.56212121212 1212	0.1242424242 42424	0.1242424
20	distance near	4	0.0050348332 6287773	2.916453948549 93	0.522222222 6667	0.0121212121 212121	0.0121212
21	sound high	1	0.0005007985 86483997	3.518513939877 89	0.51666666666 6667	0.0030303030 3030303	
22	Temperature very high	0	0	0	0.5	0	0
22	Temperature low	0	0	0	0.5	0	0
22	Brightness very high	0	0	0	0.5	0	0
22	Humidity low	0	0	0	0.5	0	0
22	Smoke high	0	0	0	0.5	0	0

Table Ac-2 Conditional Independent Probability Using Naive Bayesian Decision

	device=FO	device=FF	device=WO	device=WF
<b>SudA=Lu</b>	0.357576	0.148485	0.327272727	0.163636
<b>BrnA=Ll</b>	0.048485	0.018182	0.321212121	0.018182
<b>BdyA=Hb</b>	0.354545	0.042424	0.318181818	0.042424
<b>OstA=Ho</b>	0.357576	0.042424	0.324242424	0.042424
<b>HmtA=Hh</b>	0.357576	0.151515	0.327272727	0.163636
<b>SmkA=Ls</b>	0.357576	0.151515	0.327272727	0.163636
<b>TmpA=Ht</b>	0.354545	0.030303	0.327272727	0.163636
<b>DstA=Cd</b>	0.357576	0.042424	0.327272727	0.045455
<b>locationA=LR</b>	0.357576	0.042424	0.327272727	0.045455

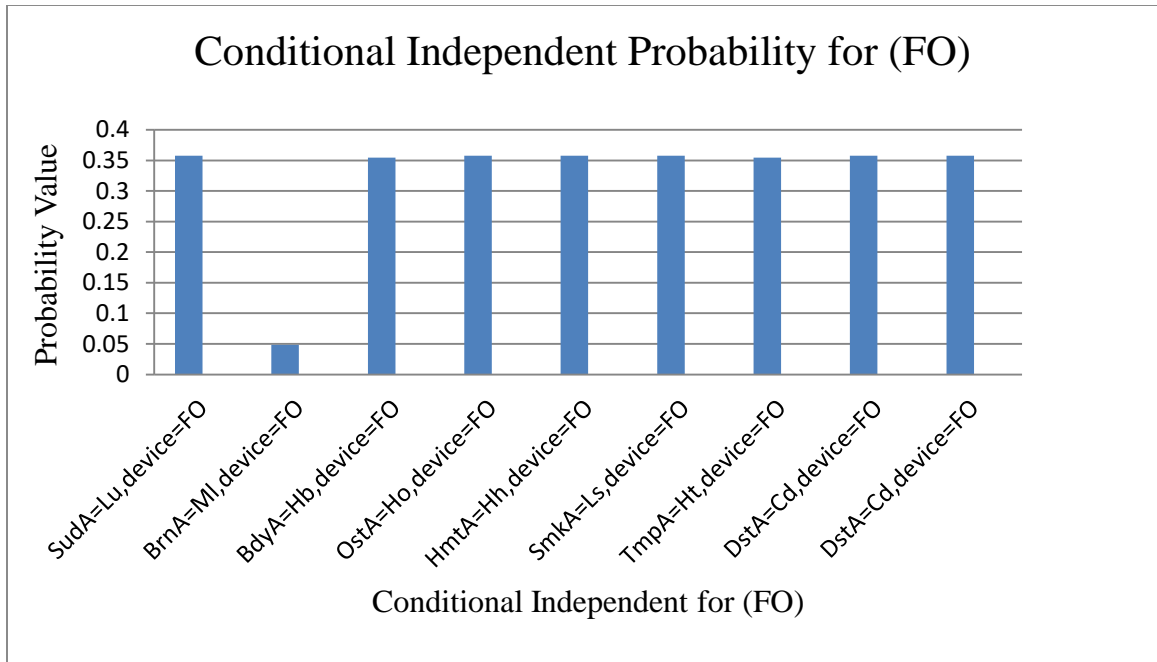

Figure Ac-1 Conditional Independent Probability Fan ON

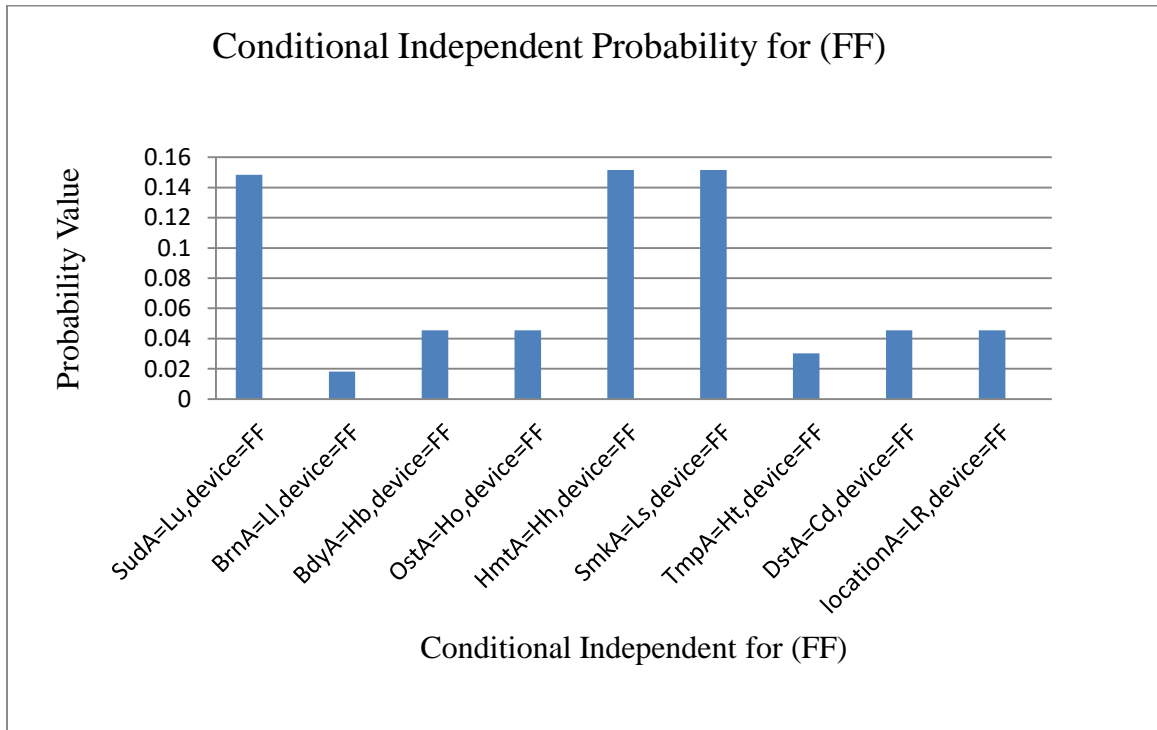

Figure Ac-2 Conditional Independent Probability Fan OFF

Appendix C

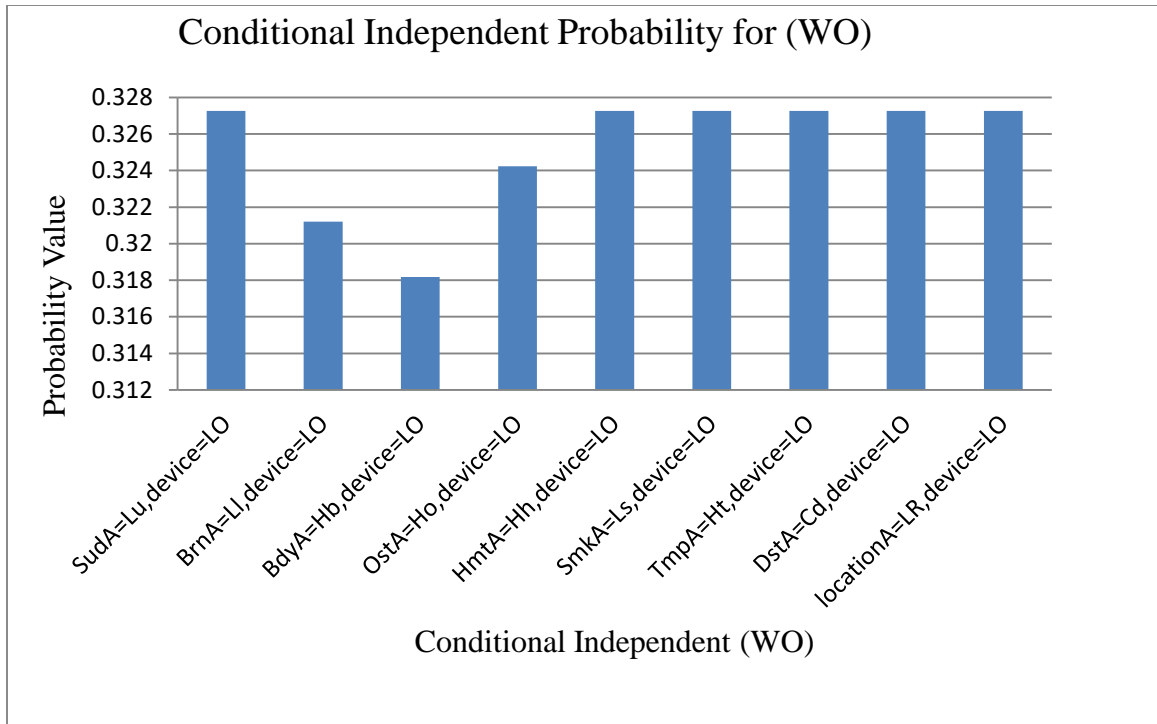

Figure Ac-3 Conditional Independent Probability Window ON

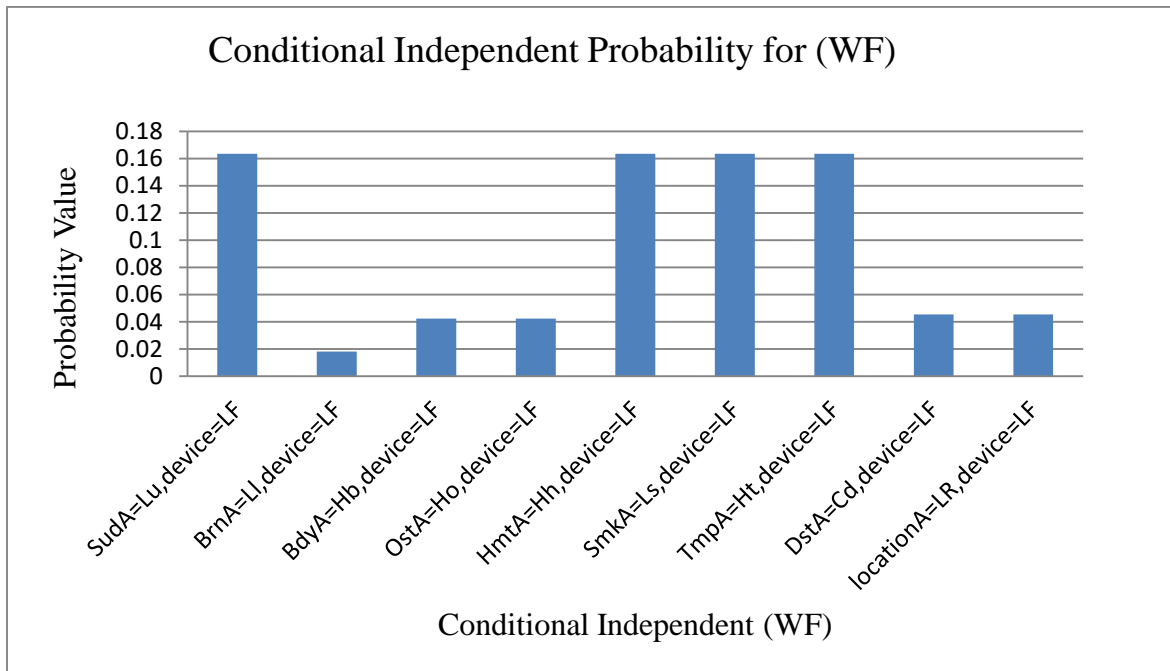

Figure Ac-4 Conditional Independent Probability Windows OFF

## Appendix D

### 1- Experimental Work and Results using Cross-validation in WEKA Tool

- **10-Fold Cross-validation Using Naive Bayes Method**

Time taken to build model: 0 seconds.

Stratified cross-validation

Correctly Classified Instances	305	92.4242 %
Incorrectly Classified Instances	25	7.5758 %
Kappa statistic	0.8924	
Mean absolute error	0.054	
Root mean squared error	0.1697	
Relative absolute error	15.0824 %	
Root relative squared error	40.1287 %	
Total Number of Instances	330	

Table Ad-1 detailed accuracy by class using NBD (10-folds)

Class	TP Rate	FP Rate	Precision	Recall	F-Measure	MCC	ROC Area	PRC Area
<b>FO</b>	1.000	0.090	0.861	1.000	0.925	0.886	0.999	0.999
<b>WF</b>	0.741	0.022	0.870	0.741	0.800	0.768	0.977	0.779
<b>FF</b>	0.800	0.000	1.000	0.800	0.889	0.879	0.969	0.901
<b>WO</b>	0.991	0.000	1.000	0.991	0.995	0.993	0.999	0.999
<b>Weighted Average</b>	0.924	0.036	0.929	0.924	0.922	0.900	0.991	0.948

Table Ad-2 Confusion Matrix classified

FO	WF	FF	WO	classified as
118	1	0	0	FO
14	40	0	0	WF
5	5	40	0	FF
0	0	0	107	WO



## Appendix D

The total number of TP for each class is:  $TP_{FO}=118$ ;  $TP_{WF}=40$ ;  $TP_{FF}=40$ ;  $TP_{WO}=107$ .

The total number of TN for each class according to equation 7.6 is:

$$TN_{FO}=40+5+40+1+107=193$$

$$TN_{WF}=118+5+40+0+107=270$$

$$TN_{FF}=118+14+40+0+1+107=280$$

$$TN_{WO}=118+14+40+5+5+40=222$$

The total number of FP for each class is:  $FP_{FO}=19$ ;  $FP_{WF}=6$ ;  $FP_{FF}=0$ ;  $FP_{WO}=0$

The total number of FN for each class is:  $FN_{FO}=0$ ;  $FN_{WF}=14$ ;  $FN_{FF}=10$ ;  $FN_{WO}=1$

**Precision (P):** from the precision equation

$$PPV_{FO} = \frac{TP}{TP+FP} = 118/118+19=0.861$$

$$PPV_{WF} = \frac{TP}{TP+FP} = 40/40+6=0.870$$

$$PPV_{FF} = \frac{TP}{TP+FP} = 40/40+0=1.000$$

$$PPV_{WO} = \frac{TP}{TP+FP} = 107/107+0=1.000$$

**Recall (R):**

$$TPR_{FO} = \frac{TP}{TP+FN} = 118/118+0=1.000$$

$$TPR_{WF} = \frac{TP}{TP+FN} = 40/40+14=0.741$$

$$TPR_{FF} = \frac{TP}{TP+FN} = 40/40+10=0.800$$

$$TPR_{WO} = \frac{TP}{TP+FN} = 107/107+1=0.991$$

**F1-measure (F1-score):**

$$F1_{FO} = \frac{2 \text{ Precision} * \text{ Recall}}{\text{ Precision} + \text{ Recall}} = 2 * 0.861 * 1.00 / 0.861 + 1.00 = 0.925$$

$$F1_{WF} = \frac{2 \text{ Precision} * \text{ Recall}}{\text{ Precision} + \text{ Recall}} = 2 * 0.870 * 0.741 / 0.870 + 0.741 = 0.800$$

$$F1_{FF} = \frac{2 \text{ Precision} * \text{ Recall}}{\text{ Precision} + \text{ Recall}} = 2 * 1 * 0.800 / 1 + 0.800 = 0.889$$

$$F1_{WO} = \frac{2 \text{ Precision} * \text{ Recall}}{\text{ Precision} + \text{ Recall}} = 2 * 1.000 * 0.991 / 1.000 + 0.991 = 0.995$$

**Accuracy (ACC):**

$$ACC_{FO} = \frac{TP+TN}{TP+FP+TN+FN} = 118 + 193 / 118 + 193 + 19 + 0 = 0.942$$

$$ACC_{WF} = \frac{TP+TN}{TP+FP+TN+FN} = 40 + 270 / 40 + 270 + 6 + 14 = 0.939$$

$$ACC_{FF} = \frac{TP+TN}{TP+FP+TN+FN} = 40 + 280 / 40 + 280 + 0 + 10 = 0.979$$

## Appendix D

$$ACC_{WO} = \frac{TP+TN}{TP+FP+TN+FN} = \frac{107+222}{107+222+0+1} = 0.997$$

Specificity (SPC):

$$SPC_{FO} = \frac{TN}{TN+FP} = \frac{193}{193+19} = 0.910$$

$$SPC_{WF} = \frac{TN}{TN+FP} = \frac{270}{270+6} = 0.978$$

$$SPC_{FF} = \frac{TN}{TN+FP} = \frac{280}{280+0} = 1$$

$$SPC_{WO} = \frac{TN}{TN+FP} = \frac{222}{222+0} = 1$$

- **Holdout (Percentage) Cross-validation Using Naive Bayes Method**

Time taken to test model on training split: 0 seconds

==== Summary ====

Correctly Classified Instances	102	91.0714 %
Incorrectly Classified Instances	10	8.9286 %
Kappa statistic	0.8761	
Mean absolute error	0.0591	
Root mean squared error	0.1823	
Relative absolute error	16.3848 %	
Root relative squared error	42.4704 %	
Total Number of Instances	112	

Table Ad-3 detailed accuracy by class using NBD (66%)

Class	TP Rate	FP Rate	Precision	Recall	F-Measure	MCC	ROC Area	PRC Area
<b>FO</b>	1.000	0.107	0.822	1.000	0.902	0.857	1.000	1.000
<b>WF</b>	0.696	0.022	0.889	0.696	0.780	0.740	0.936	0.798
<b>FF</b>	0.833	0.000	1.000	0.833	0.909	0.899	0.980	0.917
<b>WO</b>	1.000	1.000	1.000	1.000	1.000	1.000	1.000	1.000
<b>Weighted Average</b>	0.911	0.040	0.918	0.911	0.908	0.883	0.984	0.945

## Appendix D

Table Ad-4 Confusion Matrix classified

FO	WF	FF	WO	classified as
37	0	0	0	FO
7	16	0	0	WF
0	2	15	0	FF
0	0	0	34	WO

The total number of TP for each class is  $TP_{FO}=37$ ;  $TP_{WF}=16$ ;  $TP_{FF}=15$ ;  $TP_{WO}=34$ .

The total number of TN for each class according to equation 7.6 is:

$$TN_{FO}=16+2+15+34=67$$

$$TN_{WF}=37+1+15+34=87$$

$$TN_{FF}=37+7+16+34=94$$

$$TN_{WO}=37+7+16+1+2+15=78$$

The total number of FP for each class is  $FP_{FO}=8$ ;  $FP_{WF}=2$ ;  $FP_{FF}=0$ ;  $FP_{WO}=0$

The total number of FN for each class is  $FN_{FO}=0$ ;  $FN_{WF}=7$ ;  $FN_{FF}=3$ ;  $FN_{WO}=0$

Accuracy (ACC):

$$ACC_{FO}=\frac{TP+TN}{TP+FP+TN+FN} = 37 + 67/37+67+8+0 = 0.929$$

$$ACC_{WF}=\frac{TP+TN}{TP+FP+TN+FN} = 16+87/16+87+2+7 = 0.929$$

$$ACC_{FF}=\frac{TP+TN}{TP+FP+TN+FN} = 15+94/15+94+0+3 = 0.973$$

$$ACC_{WO}=\frac{TP+TN}{TP+FP+TN+FN} = 34+78/34+78+0+0 = 1.000$$

Specificity (SPC):

$$SPC_{FO}=\frac{TN}{TN+FP} = 67/67+8=0.893$$

$$SPC_{WF}=\frac{TN}{TN+FP} = 87/87+2=0.978$$

$$SPC_{FF}=\frac{TN}{TN+FP} = 94/94+0=1.000$$

$$SPC_{WO}=\frac{TN}{TN+FP} = 78/78+0=1.000$$

- **K-Nearest Neighbour Classifier Using 10-Folds**

Relation:       sensordata20

Instances:      330

Attributes:     8

## Appendix D

Test mode: 10-fold cross-validation

Correctly Classified Instances	319	96.6667 %
Incorrectly Classified Instances	11	3.3333 %
Kappa statistic	0.9534	
Mean absolute error	0.0288	
Root mean squared error	0.1218	
Relative absolute error	8.0448 %	
Root relative squared error	28.7906 %	
Total Number of Instances	330	

Table Ad-5 detailed accuracy by class using K-NN (10-folds)

<b>Class</b>	<b>TP Rate</b>	<b>FP Rate</b>	<b>Precision</b>	<b>Recall</b>	<b>F-Measure</b>	<b>MCC</b>	<b>ROC Area</b>	<b>PRC Area</b>
<b>FO</b>	0.992	0.000	1.000	0.992	0.996	0.993	0.998	0.998
<b>WF</b>	1.000	0.040	0.831	1.000	0.908	0.893	0.979	0.823
<b>FF</b>	0.800	0.000	1.000	0.800	0.889	0.879	0.978	0.926
<b>WO</b>	1.000	0.000	1.000	1.000	1.000	1.000	1.000	1.000
<b>Weighted Average</b>	0.967	0.007	0.972	0.967	0.967	0.962	0.993	0.959

Table Ad-6 Confusion Matrix classified

<b>FO</b>	<b>WF</b>	<b>FF</b>	<b>WO</b>	<b>classified as</b>
<b>117</b>	<b>1</b>	<b>0</b>	<b>0</b>	FO
<b>0</b>	<b>54</b>	<b>0</b>	<b>0</b>	WF
<b>0</b>	<b>10</b>	<b>40</b>	<b>0</b>	FF
<b>0</b>	<b>0</b>	<b>0</b>	<b>108</b>	WO

The total number of TP for each class is:  $TP_{FO}=117$ ;  $TP_{WF}=54$ ;  $TP_{FF}=40$ ;  $TP_{WO}=108$ .

The total number of TN for each class according to equation 7.6 is:

$$TN_{FO}=54+10+40+108=212$$

$$TN_{WF}=117+40+108=265$$

$$TN_{FF}=117+1+54+108=280$$

$$TN_{WO}=117+1+54+10+40=222$$

## Appendix D

The total number of FP for each class is:  $FP_{FO}=0$ ;  $FP_{WF}=11$ ;  $FP_{FF}=0$ ;  $FP_{WO}=0$

The total number of FN for each class is:  $FN_{FO}=1$ ;  $FN_{WF}=0$ ;  $FN_{FF}=10$ ;  $FN_{WO}=0$

Accuracy (ACC):

$$ACC_{FO} = \frac{TP+TN}{TP+FP+TN+FN} = 117+212/117+212+0+1 = 0.997$$

$$ACC_{WF} = \frac{TP+TN}{TP+FP+TN+FN} = 54+265/54+265+11+0 = 0.967$$

$$ACC_{FF} = \frac{TP+TN}{TP+FP+TN+FN} = 40+280/40+280+0+10 = 0.967$$

$$ACC_{WO} = \frac{TP+TN}{TP+FP+TN+FN} = 108+222/108+222+0+0 = 1.000$$

Specificity (SPC):

$$SPC_{FO} = \frac{TN}{TN+FP} = 212/212+0 = 1.000$$

$$SPC_{WF} = \frac{TN}{TN+FP} = 265/265+11 = 0.960$$

$$SPC_{FF} = \frac{TN}{TN+FP} = 280/280+0 = 1.000$$

$$SPC_{WO} = \frac{TN}{TN+FP} = 222/222+0 = 1.000$$

- **K-Nearest Neighbour Classifier Using 66%**

Instances: 330

Attributes: 8

Test mode: split 66.0% train, remainder test

Time taken to test model on training split: 0.01 seconds

Correctly Classified Instances	109	97.3214 %
--------------------------------	-----	-----------

Incorrectly Classified Instances	3	2.6786 %
----------------------------------	---	----------

Kappa statistic	0.9633
-----------------	--------

Mean absolute error	0.0337
---------------------	--------

Root mean squared error	0.1196
-------------------------	--------

Relative absolute error	9.3485 %
-------------------------	----------

Root relative squared error	27.8547 %
-----------------------------	-----------

Total Number of Instances	112
---------------------------	-----

## Appendix D

Table Ad-7 detailed accuracy by class using K-NN (66%)

Class	TP Rate	FP Rate	Precision	Recall	F-Measure	MCC	ROC Area	PRC Area
<b>FO</b>	1.000	0.000	1.000	1.000	1.000	1.000	1.000	1.000
<b>WF</b>	1.000	0.034	0.885	1.000	0.939	0.925	0.984	0.892
<b>FF</b>	0.833	0.000	1.000	0.833	0.909	0.899	0.981	0.922
<b>WO</b>	1.000	0.000	1.000	1.000	1.000	1.000	1.000	1.000
<b>Weighted Average</b>	0.973	0.007	0.976	0.973	0.973	0.968	0.994	0.965

Table Ad-8 Confusion Matrix classified

FO	WF	FF	WO	classified as
37	0	0	0	FO
0	23	0	0	WF
0	3	15	0	FF
0	0	0	34	WO

The total number of TP for each class is:  $TP_{FO}=37$ ;  $TP_{WF}=23$ ;  $TP_{FF}=15$ ;  $TP_{WO}=34$ .

The total number of TN for each class according to equation 7.6 is:

$$TN_{FO}=23+3+15+34=75$$

$$TN_{WF}=37+15+34=86$$

$$TN_{FF}=37+23+34=94$$

$$TN_{WO}=37+23+3+15=78$$

The total number of FP for each class is:  $FP_{FO}=0$ ;  $FP_{WF}=3$ ;  $FP_{FF}=0$ ;  $FP_{WO}=0$

The total number of FN for each class is:  $FN_{FO}=0$ ;  $FN_{WF}=0$ ;  $FN_{FF}=3$ ;  $FN_{WO}=0$

Accuracy (ACC):

$$ACC_{FO}=\frac{TP+TN}{TP+FP+TN+FN} = \frac{37+75}{37+75+0+0} = 1.000$$

$$ACC_{WF}=\frac{TP+TN}{TP+FP+TN+FN} = \frac{23+86}{23+86+3+0} = 0.973$$

$$ACC_{FF}=\frac{TP+TN}{TP+FP+TN+FN} = \frac{15+94}{15+94+0+3} = 0.973$$

$$ACC_{WO}=\frac{TP+TN}{TP+FP+TN+FN} = \frac{34+78}{34+78+0+0} = 1.000$$

Specificity (SPC):

## Appendix D

$$SPC_{FO} = \frac{TN}{TN+FP} = 75/75+0=1.0000$$

$$SPC_{WF} = \frac{TN}{TN+FP} = 86/86+3=0.966$$

$$SPC_{FF} = \frac{TN}{TN+FP} = 94/94+0=1.000$$

$$SPC_{WO} = \frac{TN}{TN+FP} = 78/78+0=1.000$$

- **Support Vectors Machine Classifier Using 10-Folds**

Relation:        sensordata20

Instances:       330

Attributes:      8

Test mode:    10-fold cross-validation

Number of kernel evaluations: 172 (71.044% cached)

Time taken to build model: 0.06 seconds

Correctly Classified Instances            318            96.3636 %

Incorrectly Classified Instances 12            3.6364 %

Kappa statistic                            0.9492

Mean absolute error                      0.2535

Root mean squared error                0.3138

Relative absolute error                 70.8381 %

Root relative squared error             74.1891 %

Total Number of Instances            330

Table Ad-9 detailed accuracy by class support vectors machine classifier (10-fold)

Class	TP Rate	FP Rate	Precision	Recall	F-Measure	MCC	ROC Area	PRC Area
<b>FO</b>	0.992	0.000	1.000	0.992	0.996	0.993	0.995	0.995
<b>WF</b>	1.000	0.043	0.818	1.000	0.900	0.885	0.976	0.818
<b>FF</b>	0.780	0.000	1.000	0.780	0.876	0.866	0.978	0.884
<b>WO</b>	1.000	0.000	1.000	1.000	1.000	1.000	1.000	1.000
<b>Weighted Average</b>	0.964	0.007	0.970	0.964	0.963	0.959	0.991	0.951

## Appendix D

Table Ad-10 Confusion Matrix classified

FO	WF	FF	WO	classified as
117	1	0	0	FO
0	54	0	0	WF
0	11	39	0	FF
0	0	0	108	WO

The total number of TP for each class is:  $TP_{FO}=117$ ;  $TP_{WF}=54$ ;  $TP_{FF}=39$ ;  $TP_{WO}=108$ .

The total number of TN for each class according to equation 7.6 is:

$$TN_{FO}=54+11+39+108=212$$

$$TN_{WF}=117+39+108=264$$

$$TN_{FF}=117+1+54+108=280$$

$$TN_{WO}=117+1+54+11+39=222$$

The total number of FP for each class is:  $FP_{FO}=0$ ;  $FP_{WF}=12$ ;  $FP_{FF}=0$ ;  $FP_{WO}=0$

The total number of FN for each class is:  $FN_{FO}=1$ ;  $FN_{WF}=0$ ;  $FN_{FF}=11$ ;  $FN_{WO}=0$

Accuracy (ACC):

$$ACC_{FO}=\frac{TP+TN}{TP+FP+TN+FN} = 117 + 212 / 117 + 212 + 0 + 1 = 0.997$$

$$ACC_{WF}=\frac{TP+TN}{TP+FP+TN+FN} = 54 + 264 / 54 + 264 + 12 + 0 = 0.964$$

$$ACC_{FF}=\frac{TP+TN}{TP+FP+TN+FN} = 39 + 280 / 39 + 280 + 0 + 11 = 0.967$$

$$ACC_{WO}=\frac{TP+TN}{TP+FP+TN+FN} = 108 + 222 / 108 + 222 + 0 + 0 = 1.000$$

Specificity (SPC):

$$SPC_{FO}=\frac{TN}{TN+FP} = 212 / 212 + 0 = 1.000$$

$$SPC_{WF}=\frac{TN}{TN+FP} = 264 / 264 + 12 = 0.957$$

$$SPC_{FF}=\frac{TN}{TN+FP} = 280 / 280 + 0 = 1.000$$

$$SPC_{WO}=\frac{TN}{TN+FP} = 222 / 222 + 0 = 1.000$$

- **Support Vectors Machine Classifier Using 66%**

Relation: sensordata20

Instances: 330

Attributes: 8

Test mode: split 66.0% train, remainder test BinarySMO



## Appendix D

Number of kernel evaluations: 172 (71.044% cached)

Time taken to build model: 0.06 seconds

Correctly Classified Instances            107            95.5357 %

Incorrectly Classified Instances        5            4.4643 %

Kappa statistic                            0.9386

Mean absolute error                    0.2537

Root mean squared error                0.3177

Relative absolute error                70.2897 %

Root relative squared error            74.0024 %

Total Number of Instances            112

Table Ad-11 detailed accuracy by class using support vectors machine classifier (66%)

Class	TP Rate	FP Rate	Precision	Recall	F-Measure	MCC	ROC Area	PRC Area
FO	1.000	0.000	1.000	1.000	1.000	1.000	1.000	1.000
WF	0.957	0.034	0.880	0.957	0.917	0.895	0.970	0.855
FF	0.778	0.000	1.000	0.778	0.875	0.864	0.974	0.878
WO	1.000	0.026	0.944	1.000	0.971	0.959	0.987	0.944
Weighted Average	0.955	0.015	0.958	0.955	0.954	0.944	0.986	0.934

Table Ad-12 Confusion Matrix

FO	WF	FF	WO	classified as
37	0	0	0	<b>FO</b>
0	22	0	1	<b>WF</b>
0	3	14	1	<b>FF</b>
0	0	0	34	<b>WO</b>

The total number of TP for each class is:  $TP_{FO}=37$ ;  $TP_{LF}=22$ ;  $TP_{FF}=14$ ;  $TP_{LO}=34$ .

The total number of TN for each class according to equation 7.6 is:

$$TN_{FO}=22+1+3+14+1+34=75$$

$$TN_{WF}=37+14+1+34=86$$

## Appendix D

$$TN_{FF}=37+22+1+34=94$$

$$TN_{WO}=37+22+3+14=76$$

The total number of FP for each class is:  $FP_{FO}=0$ ;  $FP_{WF}=3$ ;  $FP_{FF}=0$ ;  $FP_{WO}=2$

The total number of FN for each class is:  $FN_{FO}=0$ ;  $FN_{WF}=1$ ;  $FN_{FF}=4$ ;  $FN_{WO}=0$

Accuracy (ACC):

$$ACC_{FO}=\frac{TP+TN}{TP+FP+TN+FN} = 37 + 75 / (37+75+0+0) = 1.000$$

$$ACC_{WF}=\frac{TP+TN}{TP+FP+TN+FN} = 22+86 / (22+86+3+1) = 0.964$$

$$ACC_{FF}=\frac{TP+TN}{TP+FP+TN+FN} = 14+94 / (14+94+0+4) = 0.964$$

$$ACC_{WO}=\frac{TP+TN}{TP+FP+TN+FN} = 34+76 / (34+76+2+0) = 0.982$$

Specificity (SPC):

$$SPC_{FO}=\frac{TN}{TN+FP} = 75 / (75+0) = 1.000$$

$$SPC_{WF}=\frac{TN}{TN+FP} = 86 / (86+3) = 0.966$$

$$SPC_{FF}=\frac{TN}{TN+FP} = 94 / (94+0) = 1$$

$$SPC_{WO}=\frac{TN}{TN+FP} = 76 / (76+20) = 0.974$$

Table Ad-13 Predictions on Holdout 66.0% test context-aware database history

Instance	Actual	Predicted	Error Prediction	Instance	Actual	Predicted	Error Prediction
1	3:FF	2:WF	+ 0.893	57	1:FO	1:FO	0.988
2	2:WF	2:WF	0.893	58	4:WO	4:WO	0.986
3	1:FO	1:FO	0.988	59	3:FF	3:FF	0.986
4	4:WO	4:WO	0.986	60	1:FO	1:FO	0.988
5	1:FO	1:FO	0.988	61	1:FO	1:FO	0.988
6	4:WO	4:WO	0.893	62	3:FF	1:FO	+ 0.615
7	1:FO	1:FO	0.988	63	2:WF	1:FO	+ 0.615
8	1:FO	1:FO	0.988	64	1:FO	1:FO	0.988
9	1:FO	1:FO	0.988	65	1:FO	1:FO	0.988
10	1:FO	1:FO	0.988	66	3:FF	3:FF	0.924
11	4:WO	4:WO	0.986	67	4:WO	4:WO	0.986
12	4:WO	4:WO	0.986	68	1:FO	1:FO	0.988
13	2:WF	1:FO	+ 0.615	69	4:WO	4:WO	0.986
14	1:FO	1:FO	0.988	70	2:WF	2:WF	0.893
15	3:FF	3:FF	0.926	71	2:WF	2:WF	0.893
16	4:WO	4:WO	0.986	72	3:FF	3:FF	0.926
17	1:FO	1:FO	0.988	73	3:FF	3:FF	0.926
18	4:WO	4:WO	0.986	74	4:WO	4:WO	0.986
19	2:WF	2:WF	0.893	75	4:WO	4:WO	0.986
20	2:WF	1:FO	+ 0.615	76	2:WF	1:FO	+ 0.615
21	1:FO	1:FO	0.988	77	4:WO	4:WO	0.986

## Appendix D

22	2:WF	2:WF	0.893	78	3:FF	3:FF	0.926
23	2:WF	2:WF	0.893	79	4:WO	4:WO	0.986
24	2:WF	2:WF	0.893	80	1:FO	1:FO	0.988
25	2:WF	2:WF	0.893	81	1:FO	1:FO	0.988
26	4:WO	4:WO	0.986	82	2:WF	2:WF	0.893
27	3:FF	3:FF	0.926	83	1:FO	1:FO	0.988
28	2:WF	2:WF	0.893	84	1:FO	1:FO	0.988
29	2:WF	2:WF	0.893	85	4:WO	4:WO	0.986
30	2:WF	2:WF	0.896	86	1:FO	1:FO	0.988
31	1:FO	1:FO	0.988	87	2:WF	1:FO	+ 0.615
32	1:FO	1:FO	0.988	88	4:WO	4:WO	0.986
33	2:WF	2:WF	0.893	89	3:FF	3:FF	0.923
34	1:FO	1:FO	0.988	90	3:FF	3:FF	0.883
35	3:FF	3:FF	0.923	91	4:WO	4:WO	0.986
36	3:FF	3:FF	0.935	92	3:FF	2:WF	+ 0.893
37	1:FO	1:FO	0.988	93	3:FF	3:FF	0.926
38	1:FO	1:FO	0.988	94	4:WO	4:WO	0.986
39	2:WF	2:WF	0.893	95	3:FF	3:FF	0.926
40	1:FO	1:FO	0.988	96	1:FO	1:FO	0.988
41	4:WO	4:WO	0.986	97	4:WO	4:WO	0.986
42	2:WF	2:WF	0.893	98	2:WF	2:WF	0.893
43	4:WO	4:WO	0.986	99	4:WO	4:WO	0.986
44	4:WO	4:WO	0.986	100	1:FO	1:FO	0.988
45	1:FO	1:FO	0.988	101	1:FO	1:FO	0.988
46	2:WF	1:FO	+ 0.615	102	4:WO	4:WO	0.986
47	4:WO	4:WO	0.986	103	1:FO	1:FO	0.988
48	1:FO	1:FO	0.988	104	4:WO	4:WO	0.986
49	3:FF	3:FF	0.926	105	4:WO	4:WO	0.986
50	1:FO	1:FO	0.988	106	1:FO	1:FO	0.988
51	4:WO	4:WO	0.986	107	4:WO	4:WO	0.986
52	3:FF	3:FF	0.926	108	4:WO	4:WO	0.986
53	1:FO	1:FO	0.988	109	2:WF	1:FO	+ 0.615
54	4:WO	4:WO	0.986	110	4:WO	4:WO	0.986
55	1:FO	1:FO	0.988	111	1:FO	1:FO	0.988
56	4:WO	4:WO	0.985	112	4:WO	4:WO	0.986