



University of HUDDERSFIELD

University of Huddersfield Repository

Ngigi, R. W., Pislaru, Crinela, Ball, Andrew and Gu, Fengshou

Modern techniques for condition monitoring of railway vehicle dynamics

Original Citation

Ngigi, R. W., Pislaru, Crinela, Ball, Andrew and Gu, Fengshou (2012) Modern techniques for condition monitoring of railway vehicle dynamics. *Journal of Physics: Conference Series*, 364. 012016. ISSN 1742-6596

This version is available at <http://eprints.hud.ac.uk/id/eprint/13921/>

The University Repository is a digital collection of the research output of the University, available on Open Access. Copyright and Moral Rights for the items on this site are retained by the individual author and/or other copyright owners. Users may access full items free of charge; copies of full text items generally can be reproduced, displayed or performed and given to third parties in any format or medium for personal research or study, educational or not-for-profit purposes without prior permission or charge, provided:

- The authors, title and full bibliographic details is credited in any copy;
- A hyperlink and/or URL is included for the original metadata page; and
- The content is not changed in any way.

For more information, including our policy and submission procedure, please contact the Repository Team at: E.mailbox@hud.ac.uk.

<http://eprints.hud.ac.uk/>

Modern techniques for condition monitoring of railway vehicle dynamics

R W Ngigi, C Pislaru, A Ball and F Gu

The Centre for Diagnostic Engineering, University of Huddersfield, Queensgate, Huddersfield, HD1 3DH, UK

Email: roy.ngigi@hud.ac.uk

Abstract. A modern railway system relies on sophisticated monitoring systems for maintenance and renewal activities. Some of the existing conditions monitoring techniques perform fault detection using advanced filtering, system identification and signal analysis methods. These theoretical approaches do not require complex mathematical models of the system and can overcome potential difficulties associated with nonlinearities and parameter variations in the system. Practical applications of condition monitoring tools use sensors which are mounted either on the track or rolling stock. For instance, monitoring wheelset dynamics could be done through the use of track-mounted sensors, while vehicle-based sensors are preferred for monitoring the train infrastructure. This paper attempts to collate and critically appraise the modern techniques used for condition monitoring of railway vehicle dynamics by analysing the advantages and shortcomings of these methods.

1. Introduction

The 21st century has brought more pressures to the railway industry stakeholders to deliver more. Currently, there has been an increase in demand from rail commuters for affordable and high quality services. Since rail plays a crucial role in stimulating economic growth, legislators are demanding for a more sustainable industry. These challenges serve as an opportunity for the industry to invest more on the right technology. For example, a 24 x 7 railway requires the minimisation of disruptions caused by activities such as inspection, remedial, remove and reactive maintenance, and track renewal. So, it is necessary to conduct more effective inspection and maintenance in less time by optimising and automating these activities where possible. To avoid unplanned outage so as to meet the growing demands on cost efficiency, reliability and safety for railway vehicles, the argument for implementing intelligent condition monitoring systems is highly desirable.

The dynamics of a railway vehicle represents a balance between forces acting at the wheel-rail interaction, suspension forces and inertia forces. The excessive response of the rail vehicle to track irregularities can result in poor guidance and ride quality which may increase wear on the wheel and rail, and can lead to derailment [1]. The modern intelligent railway vehicle relies on sophisticated monitoring systems to foresee its overall dynamic behaviour during normal operation and identify imminent critical conditions. Several concepts and tested hypotheses have been developed to monitor these dynamics that are unique to railway vehicles.

A number of techniques have been utilised to perform fault detection in railway vehicles. They include, advanced filtering, system identification and signal analysis methods. These techniques are

used to detect and identify faults that deteriorate with time [2]. Although, the railway vehicle is a dynamically-complex multi-bodied system that is highly nonlinear, these approaches require less complicated mathematical models of the system and can overcome potential difficulties associated with nonlinearities and parameter variations.

The practical application of condition monitoring of the train dynamics are done either through the employment of track-based sensors or vehicle-based sensors. Mostly, the track bed-based sensors are used to monitor the condition of wheelset, whereas, the rolling stock-based sensors are concerned with the monitoring of the rolling stock infrastructure. Modern rolling stock is fitted with high-capacity communication buses and multiple sensors which require advance processing units for data collection and management. For instance, an on-board data processing unit should have decision-making capabilities, hence, should be able to decide how much data to store depending on the severity of the fault and priority of notification.

This paper aims to give an overview of the existing condition monitoring techniques applied to monitor railway vehicle dynamics. Section two presents the model-based techniques (Kalman filters; extended Kalman filter; sequential Monte Carlo method (Rao-Blackwellised particle filter)) used to estimate the dynamics of the rail vehicle systems. The section also describes the signal - based techniques (band-pass filter; spectral analysis, wavelet analysis; Fast Fourier Transform) which are used to detect the wheel faults. Section three describes some practical applications of condition monitoring systems employing vehicle based and track based sensors. Also the emerging technologies that may be available in the future for effective wheelset condition monitoring are analysed.

2. Condition monitoring techniques

The significance of employing advanced information technology for condition monitoring purposes in industries is highly appreciated. The condition monitoring technique has considerably evolved over the years since it began as a measurement-oriented strategy. More emphasis now has been placed on computer-based stratagem. More reliance on computer systems is as a result of their efficiency in sending, storing and analysing large amount of data. Measuring instruments are using standard computer components and operating systems in order to be cost effective. These changes offer new possibilities for utilising condition monitoring of various system parameters and also, the integration of several disciplines in the field of condition monitoring and diagnosis which existed independent of one another [3].

In order for the railway industry to successfully implement condition-based maintenance, a good condition monitoring tool which can predict or detect incipient faults in real time is required. It has been accepted that, when a fault is imminent, there is certainly parametric deviation within the system. In such instances, parameter and state estimation techniques are more likely preferred for information extraction. Quite often direct measurements of parameters, especially for the rail vehicle dynamic system are not readily available due to several limitations, for example, high cost of implementation, or lack of adequate technology. Generally, condition monitoring for railway vehicle systems aids in reducing unscheduled downtime by allowing appropriate maintenance to be scheduled.

A proper condition monitoring device to be implemented on a railway vehicle system requires added features like safety and reliability. Hence, the choice of condition monitoring technique is very important and should be selected based on how it can handle sever nonlinear system, robustness, sensitive to disturbances and computation performance. This section presents various techniques used to estimate unmeasurable parameters for the purpose of condition monitoring of the railway vehicle.

2.1. Model-based techniques

The model-based methodologies are preferred when there is no direct measurement of parameters but there is access to the relationship between the input and output signals [2]. The model-based diagnostic techniques have been used to identify faults in dynamic systems through the evaluation of residuals. One particular interesting technique among the model-based techniques is the observer-based fault detection filter design (see Figure 1). The observer-based methods are effective in

detecting sensor, actuator, and system component failure but present difficulties when applied to systems which are subjected to unknown disturbances and model uncertainties [4]. A possible cause of these difficulties could be in the selection of the initial values and state vector when considering partial linearization. Even so, there is no guarantee that the estimated parameters will converge [5].

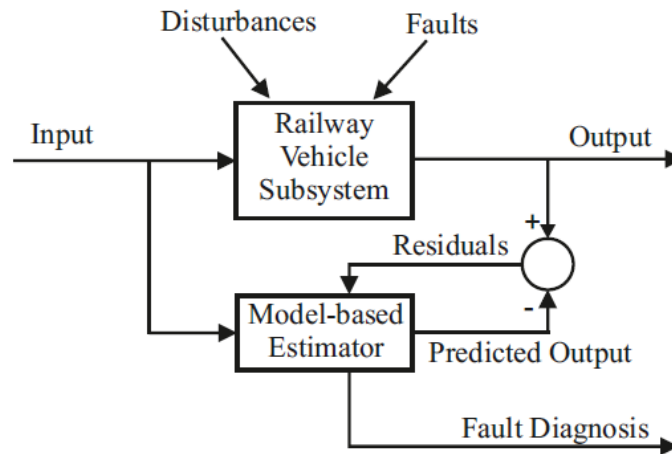

Figure 1. Observer-based fault detection method [5].

The commonly studied method for estimation of dynamic systems that uses an observer for fault detection is the Kalman filter (KF) for linear systems and the extended Kalman filter (EKF) for nonlinear stochastic systems [6]. Nowadays, the Kalman filter is one of the most popular methods used for state and parameter estimation. It utilises measurements linearly related to the state and error covariance matrices to generate a gain referred to as Kalman Gain. This gain is applied to the prior state estimate, thus, creating a posterior estimate. The estimation process continues in a predictor-corrector manner while maintaining a statistically minimal state error covariance matrix. The interaction between the wheel and the rail profiles influences the dynamic behaviour of a railway vehicle. This dynamic interaction is nonlinear and is due to the complication arising from the contact patch, geometry and creep. Typically these dynamics are usually analysed using the creep coefficients and the conicity. Charles et al [7] used the Kalman filter approach to estimate the nonlinear geometries as a nonlinear conicity function. Their estimator tracked the parameters well but there were some degree of uncertainties especially for lower conicity values. Thus, the authors pointed out that incorporating multiple Kalman filter models was best suited for the investigation. Tsunashima and Mori [8] demonstrated the possibility of detecting railway vehicle suspension failure using the multi-model approach. Their method incorporated a set of mathematical models in the initial step (model design to represent different failure modes) before designing model-based filters based on each model. They examined the validity of the approach by investigating the secondary lateral damper and spring failure in railway vehicles using Kalman filter as a mode-matching filter. Despite their simulation result showing that the mode probability in the interacting multiple model (IMM) is effective for fault detection, the number of model history increases exponentially with time which can bring implementation problems [5]. Other notable applications that use Kalman filter approach for parameter estimation includes creep force [9-10], creep coefficients [11] and suspensions [12].

Another method is the sequential Monte Carlo (also known as particle filter) which in principle takes the Bayesian approach to estimate the states and parameters, whereby one attempts to accurately represent the probability distribution function of the parameters of interest. Though it is relatively new, it has taken many forms over the years and this has made it popular particularly for solving estimation problems for nonlinear systems. Li et al [13] implemented the Rao-Blackwellised particle filter to estimate the secondary lateral and anti-yaw damping coefficients of the railway vehicle dynamic

model then compared the findings with that of EKF. The idea behind Rao-Blackwellisation is to reduce the computational requirement and increase the efficiency of the particle filter by reducing the size of the augmented state space through marginalizing out some of the variables. Their simulations indicated that there was some degree of uncertainty in the wheelset conicity estimates. This could have been because of the track roughness and the wheel profile, thus, they concluded that, an explicit non-linear estimate would suffice

System identification technique entails fitting parametric values to a set of measured states or regressors to minimise the square of the error of the estimated output to the real output. Due to unavailability of prior knowledge, 'black box' model is used, but if there is some knowledge of the system then 'grey box' model is employed for parameter identification of the unknown state or regressor. Charles et al [14], proposed a least-square approach to estimate the conicity function shape. A piecewise cubic function approach was used to estimate the nonlinear function. The parameters for the cubic functions were estimated using the least squared approach from measured data collected from the system. Even though the method estimated the nonlinear wheel geometry function, one of the assumptions they made was that the track input noise was white, which is normally coloured.

Predicting models developed by Shafiullah et al [15] using regression algorithms were used to investigate the vertical acceleration behaviour of railway wagons that are attached to a moving locomotive using modern machine learning techniques. Different types of models were built using a uniform platform to evaluate their performance. The set of attributes that were used to evaluate the estimation algorithm are; correlation coefficient, root mean square error, mean absolute error, root relative squared error, relative absolute error and computational complexity. Both front and rear body vertical acceleration conditions were predicted using ten common regression algorithms. Although, the accuracy of the models varied based on several factors, the linear regressor algorithm performed better overall than any other algorithm.

2.2. Signal-based techniques

In some instances, the output signal is the only signal available; therefore, the signal-based methodologies are relevant in such instances. The measured signals are analysed in response to some form of disturbance. The extraction of fault-relevant signal characteristics can in many cases be restricted to the amplitudes or amplitude densities within a certain bandwidth of the signal. Parametric signal models can be used to estimate the parameters by analysing the changes in the frequencies and their amplitudes. The signal processing methods used are spectral analysis, wavelet analysis and band-pass filters [5].

These methods are useful for extracting the frequency range related to faults. However, it is difficult to detect faults as the characteristics can vary with conditions and the acceleration state of the running vehicle. For instance, Oba et al [16] developed a condition monitoring algorithms for fault detection in Shinkansen bogies. The two algorithms proposed are based on statistical analysis of vibration acceleration during certain periods. One algorithm analysed the peak vibration distribution of operation with non-faulty parts and with faulty parts. The vibration states of the front and rear bogies were compare using the other algorithm for one faulty bogie. One of the assumptions made was that the faults in the rotating parts on the bogie are related to their rotational frequencies. The faults were successfully detected by applying an appropriate band-pass filter and evaluating the difference in the shape of the distribution for the vibration states.

A diagnostic tool is presented by Belloti et al [17] which use wavelet transform to detect wheel-flat defect of a test train. The rail was instrumented with four accelerometers and an inductive axle-counter block for assessing the train speed and health status of the wheel. The technique was found to have a high efficient in detecting damaged wheels as well as measuring the train speed. The estimation method considered that the impact force from the wheel-flat and the wheel-flat length to be linear for which they are highly nonlinear.

Zhang et al [18] set an online test to monitor the vibration characteristics of a train wheelset. They analysed the impacts of vibrations on the axle box bearings using characteristic spectral analysis. The

vibration sensors were mounted on the axle box bearings to extract the vibration signals then sent to a data acquisition circuit through the signal condition and demodulation circuit. Another signal detected by a photo-electric speed sensor was sent to a measurement and sampling unit for analysis. The measured signals were then transformed from time to angle domain discrete signals and then to characteristic domain signals. From this characteristic signal, the fault in the axle box bearing was identified. Their studies showed that, the diagnostic system performed as expected and as far much better than the conventional spectral analysis method.

In the paper by Mehrpouya and Ahmadian[19], a superelement technique is proposed to identify the forces that are exerted on the wheelset. A finite element (FE) model of a railway freight vehicle was adopted for the analysis. The model developed comprised of two-axle bogies and a freight wagon. In their studies, the model update was performed in two stages. The first stage, the bogie model was updated using data measured from the actual bogies, and the second stage, the whole vehicle model was updated from data obtained from the actual vehicle system. Due to the increased computational cost of their technique, a superelement analysis method was found to be appropriate in order to reduce the model to an acceptable level for computational purposes. The resultant model was applied for force identification scheme conducted on the frequency domain. Their results indicated that the procedure gave acceptable estimates of the low frequency range forces. They concluded by indicating that the technique investigate is suitable for detecting forces during normal operation of the rail vehicle and also viable in predicting parts of the track where the forces exceed the permissible range.

3. Examples of practical applications of condition monitoring systems employing vehicle-based and track-based sensors

Today, most of the commercially available products for condition monitoring of railway vehicles are predominantly focused on the bogie system; this is because some of its critical components change their parameters rapidly when in operation and can pose safety related issues. The key concept here is the ability of the existing technology to monitor and identify these parameters in real time for condition monitoring and predictive maintenance purposes. Different sensor configurations are currently being implemented in the industry for monitoring railway vehicle parameters; but they mainly fall as either on-board (vehicle-based) or track-based systems (see Figure 2a and 2b).

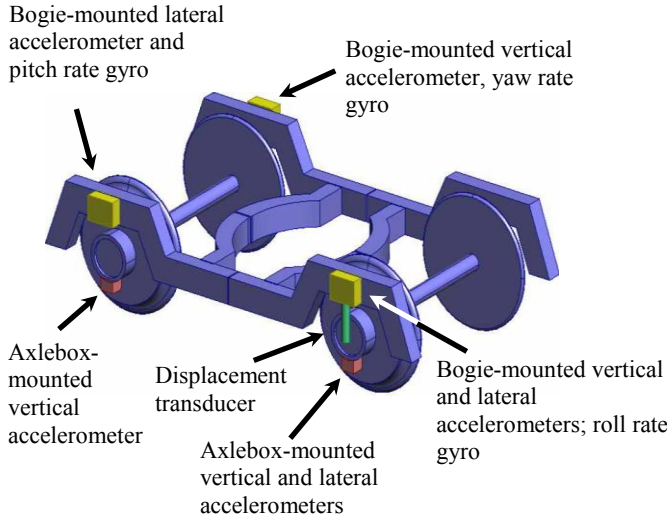

Figure 2a. Bogie and wheelset sensor position [2].

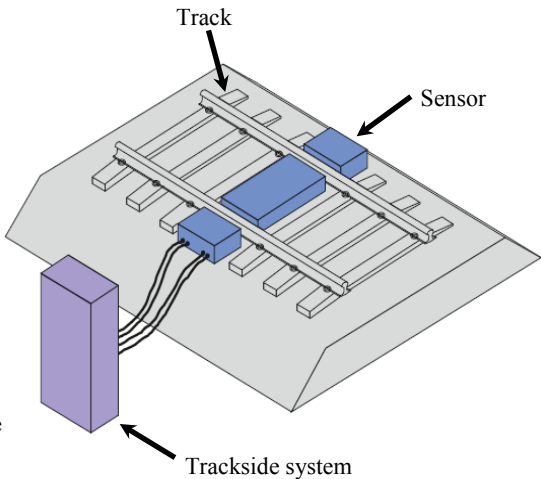

Figure 2b. Trackside sensor configuration.

Condition monitoring technology within the railway industry has proliferated in recent years; this is due to the continuous improvement of electronic-based systems. This has created a unique situation

for implementing proactive condition monitoring technology in the railway industry. This approach will create the possibilities of identifying failing systems while the asset is in operation before they create catastrophic damage. Economically, most of these proactive products are wayside condition monitoring systems and very few sensors are directly mounted on the vehicles. Another reason is that the cost of monitoring the condition of the bogie will be expensive than the faults they are handling. There are enormous amount of trains in operations and to equip them with several detectors is a challenge in regards to cost and maintaining the overall detector technology [20].

3.1. Vehicle-based sensors

Sensors mounted on a railway vehicle can be used to identify track irregularities, bogie dynamic performance and absolute train speed. The sensor networks on the bogies are instrumental in identifying track irregularities [2]:

- Pitch rate gyro can be used to obtain the mean vertical alignment of the track at longer wavelength.
- Axlebox accelerometers can be used to measure the vertical track irregularities at shorter wavelength.
- Bogie roll rate gyro are used to approximate the track cross level for longer wavelength.

The combination of the roll and yaw rate gyro together with the lateral sensing accelerometer can be used to estimate the absolute roll of the track. The use of these sensors allows the twist from the design transitions to be included in the absolute twist estimate [2]. The speed of the vehicle is very important while acquiring the data because it is necessary for performing conversion between time and displacement along the track.

In spite of the fact that the bogie mounted sensors are adequate for monitoring track irregularities, they can also be used to identify deviation in the rail vehicle performance. Mei and Li [21] used the inertial sensors which were mounted on the bogie to monitor the vehicle dynamic response to track excitation. The advantage of this method is that, it eliminates the inaccuracy inherent with position encoders especially when the wheel is in slip/slide mode. The rail vehicle pitch and bounce accelerations were successfully estimated using two separate filters. This approach was used for filter design simplification by decoupling the interactions in the system. The drawback with this scheme is that at high speeds the time shift (delay) between two signals is small, thereby introducing large errors in the measurement.

In another application Monje et al [22], developed an intelligent sensor that can measure the rolling contact fatigue at the wheel rail interaction. The technique comprised of an optical sensor (emitter and detector photodiodes) attached to the bogie (i.e. positioned facing the wheels) and a radio transmitter for sending radio frequency to a configuration circuit. In the analysis, the detectors were able to detect the sliding effect at the wheel rail contact point. The test deduced that the wheels do not roll evenly at all time. The major bottlenecks of using the optical sensors for such applications is that it can only be used for short term application and that things like dirt and dust clogging on the detector may induce measurement disparities.

Matsumoto et al [23] adopted a different approach to estimate the forces at the wheel-rail interface. The proposed method relied on non-contact gap sensors to detect wheel distortion rather than strain gauges or load cells. Unlike conventional sensors which are usually attached to the wheel rim, the gap sensors are mounted on the non-rolling part of the bogie (sensor base is attached on the bearing box) but close to wheel rim. Since the movement of the wheelset cannot be neglected, two gap sensors were employed to compensate for the movement. Although, the measuring unit could be improved by inclusion of more gap sensors to compensate for contact point difference and the structure of the wheel surface, their results showed that the method can be used to extract satisfactory data.

Bleakley and Senini [24] presented an online tool for analysing the acceleration signals acquired from accelerometers mounted on the body frame of a wagon. The dual-axis sensors were configured to measure the lateral and vertical accelerations. The signals were converted from time to frequency domain using fast Fourier transform (FFT) in order to establish their spectral composition. Though, the

detection method developed provided a set of coefficients according to the frequencies interest, the results they obtained were similar to the short term RMS value via its frequency domain. From their results, there was some significant improvement on the signal to noise ratio (from 5/4 to 4/2) thereby making it suitable for online detection. Even though their approach performed as expected, they pointed out that a further improvement on the weighting and summation vector could enhance the detection capabilities significantly.

3.2. Track-based sensors

Incorporating sensors on the track for condition monitoring purposes is to ensure the smooth running of rail vehicle and no sudden disruption on the railway line. However, these systems are not that reliable and in most cases the inspection of railway vehicles takes place in the depot before it leaves for operation. Such inspections are time-consuming and prone to human error. These techniques have been around for many years, but an increase in damaged wheelset due to higher speeds, heavier loads and modified operating conditions has led the rail stakeholders to re-evaluate these inspections strategies.

Brickle et al [25] produced a report on the current and emerging state-of-art automated systems that employ track-based sensors for wheelset condition monitoring (WCM). The research commissioned by the Rail Safety and Standard Board (RSSB) UK identified the following functional categories of automated WCM inspection systems:

- *Wheel profile monitoring systems* – these systems extracts data from the actual wheel profile which will be used to compare with measurement from a new wheel profile so as to make key analysis. Most of the available wheel profile measuring systems employs non-contact technique to monitor the wear on the wheel as the train passes. A laser line or high-intensity strobe light illuminates the wheels and the images are captured using high-speed digital cameras. The extraction of the wheel parameters is done using specialized computer software. The problem with such systems is the ability to identify cracks in the plate, rim, and flange and tread region. Some of the current systems that are commercially available for wheel profile measurement include DeltaRail's Treadview, ImageMap's WheelSpec, Beena Vision's WheelView and LynxRail's ATEx. The treadView developed by DeltaRail (UK) comprises of a series of lasers and cameras installed on the track. As the train passes by at low-speed (less than 10mph) the images of the wheel are captured then sent to a computer for image analysis. The wheel parameters (flange height and width, tread hollow and rim thickness, for example) are calculated and then stored so as to build each wheel wear history [26].
- *Wheel impact load detectors (WILD)* – This type of measuring system detect the presence of a defective wheel by measuring the magnitude of the load (amount of force the wheel exerts to the rail) and comparing it to the specified threshold. WILD depend on optical sensor, accelerometers, load cells or strain gauges to measure and detect wheel defects. Out-of-round, shelling or flat spots characteristics on the wheels induce excessive impact on the rail and can contribute to wear and tear of track and vehicle. The rail deflection caused by the vertical forces exerted by the wheels is measured and analysed to determine the wheel tread irregularities. The available systems in market are GE Transportation's MATTILD, DeltaRail's Wheelchex, Teknis' WCM and Salient System's WILD. Also Gotcha-QuoVadis by Baas R&D is another WILD product that uses optical sensors to measure wheel defects. The force applied by the wheels as the rail vehicle passes is measured through the deflection of the rails. The data collected from the sensors is analysed using Gotcha software to identify the overall quality of the wheel.
- *Bogie performance detectors* – These are wayside systems implemented to identify the level of performance for railway vehicles. Different systems employ different measurement strategies, for instance, the hunting truck detector (HTD) by Salient systems measures the lateral force exerted on the rail in order to identify vehicles that shows excessive hunting

motion through the evaluation of the hunting index (railway safety technology). Some other systems like the TBOGI by wayside inspection devices (WID) uses laser technology to assess the bogie wheelset angle of attack and its respective position on the track. The data collected from the TBOGI system is analysed to detect faults in bogie like misalignment, skewed or warped. Even though such systems are effective in their applications but they fall short in monitoring defective springs. Other available systems include GE Transportation system's MATTILD, LynxRail's ATE_x and Salient systems' truck performance detector (TPD) [26].

- *Tread condition detectors* – Most systems in this category applies the non-destructive ultrasonic sensor technology, to detect the presence of any discontinuity caused by surface breakings/cracks on the tread surface of the wheel. The ultrasonic waves transmitted by the detector transducers propagates through the wheel, and in case there is a crack, then the signal will be attenuated which will be sensed by the transducers. Lasers have been successfully implemented in ultrasonic wave generations which are detected by non-contact ultrasonic transducers. For example the Module 2000 DSR by Talgo utilizes the nondestructive ultrasonic detection technique to measure the wheel tread surface. The system (DSR) is adequate in determining surface breaking or cracks on the wheel as the train moves at speed of 6mph or less. Another detector that uses ultrasonic detection is the Argus by Hegenscheidt MFD.
- *Hot axle bearing* – They are used to detect anomalous hot wheel bearings. Thermal sensors extract heat signature from the bearings to establish any indication of failure. The hot axle bearing detection technology has developed over the years since it started in the early 1960s. The systems then depend on thermal sensitive resistors to detect infrared radiation. On the contrary, current systems utilize infrared image processing techniques to obtain more accurate measurement while the train is operating at speeds of about 310mph maximum. The Pegasus by ITSS is a good example of a hot bearing detector that uses multi-element sensors configuration to provide thermal data of bearings, wheel discs and brakes. The pegasus can measure bearing temperatures between 0 to 150C when the train is travelling at 310mph. Additional systems that are available include, Harbin VEIC's HTK 499 hot bearing detector system, GE Transportation system's micro hot bearing detector and Schenck's MULTIRAIL hot box detector system.
- *Hot and cold wheel detectors* – The technology used for hot and cold wheel detection is quite similar to that of hot bearing detectors because both techniques rely on infrared images for wheel temperature analysis as the train is moving at high speed. When the rail vehicle's brakes are stuck or fully released during normal operation this is an indication of hot wheel temperature whereas for cold wheel temperature, the brakes have malfunction (failed to apply). The systems that are current used in the railway industry are mostly provided as an add-on module to the hot bearing detector, however, the GE Transportation systems' micro hot wheel detector can be supplied as an add-on or standalone module for brake inspection.
- *Acoustic bearing defect detectors* – Microphone array detector are used to record the characteristic of sound made by bearings as the train passes. Noise and excessive vibration of the bearings will be produced as they start to fail. This type of detectors are more mature than the hot axle bearing by reason of, that they are highly sensitive and can predict failing bearings in advance. According to [], the recent acoustic detectors should be able to detect at least 35 % of hot bearing failures. Examples of acoustic bearing defect detectors are TTCI's Trackside Acoustic Detection System (TADS®) and VIPAC's RailBAM®.
- *Automatic vehicle identification (AVI) systems* – The substantial use of AVI system is significant as it helps in transmission of data from rail vehicles with defective components to the maintenance crew at the depot for corrective action. For instance, rail vehicles are equipped with radio frequency identification (RFID) tags which are preprogrammed for

specific vehicles. As the train passes an area with vehicle identification reader, radio frequency energy is sent to a certain area of the track to analyse the tread and wear patterns of moving trains. When the train has passed, the data is sent back via GPRS to centralized database for optimization and analysis. TransCore and TagMaster are some of the leading manufacturers of RFID tags and readers used in the railway industry for AVI systems.

- *Brake pad inspection systems* – This type of inspection system captures digital images of brake pads and then use the current machine vision technology to ascertain the wear rates, uneven wear and also detect missing brake pad. PadView by DeltaRail uses cameras and strobe light mounted beneath the track to assess the condition of the brake pad. Other systems that use machine vision technology include; Brake block measurement system by MRX Technologies and FactIS by Lynxrail and TTCL.

The identified technologies by Brickle et al [25] identified several emerging technologies that utilise track-based sensors for effective railway vehicle condition monitoring.

- *Train fault detection system (TFDS)* – TFDS is a system that integrates high speed digital image acquisition, real-time image data processing and pattern recognition technology to assess various safety critical components of railway vehicles. The machine vision technology is used to capture images of the bogie system to detect key parts that are essential for safe operation. The components that are inspected include springs, brake shoe and pin, bearings adapter and end cap, brake beam, and coupling components. High speed video cameras collect the images of a moving train, analyse and process them using computer-aided technology to detect deficiency, fractures, and other faults on the train. The apparent application of TFDS has transformed from manual detection and maintenance to computer-based detection and manual maintenance.
- *Laser-based ultrasonic cracked axle detection* – This state-of-art technology for crack axle detection utilises a laser in conjunction with standard ultrasonic transducer to detect flaws on the axle. The ultrasonic waves generated by the high-energy pulsed laser introduces high frequency sound waves to the axle, the feature of the received signal by air-coupled transducer is sent to a signal processing unit for analysis to determine cracks across the axle circumference. In order to achieve a comprehensive measurement data, multiple inspections are done on the axle.
- *Automated ultrasonic-based cracked wheel detection* - This is a trackside oriented system for monitoring railway wheels using ultrasonic sensor approach. The wayside cracked wheel detection system by Dapco utilises the ultrasonic technology to detect cracked wheels as the train travels at speeds of up to 5mph. The data collected from the four test stations is analysed using pattern recognition technique so as to provide real-time evaluation of the flaw size, type, and location. The system is designed to identify cracked/shattered wheels which are above 0.5 inches. In consequence of the fact that the detector needs to access the wheel tread for maximum data extraction, a flange bearing rails is supplied on the track and a couplant (to facilitate ultrasonic wave transmission) that is pumped through the coupling of the ultrasonic sensor and wheel. This type of system is robust and can be applied to different environmental conditions.
- *Displacement sensor-based bogie hunting detection* – Excessive hunting experienced by a train during high-speed operation can cause derailment, thus, a wayside system proposed by LynxRail that utilises an array of inductive displacement sensors is used to detect the hunting phenomenon. The displacement sensors used are capable of providing quality information about various wheelset parameters relative to the track. The LynxRail system is capable of detecting hunting for railway vehicle traveling at lower speeds.

Wei et al [27] presented a real-time wheel defect monitoring system that used Fibre Bragg Grating (FBG) sensors. The sensors were mounted on the track to measure the wheel-rail interaction in relation to the strain imposed on the track by this interface. The strain signal of the wheels collected from the sensors was analysed using a condition index (CI) system. The problem of using the CI is that, if one of the wheels was in bad condition, the system will not be able to make a distinction of which wheel is faulty. One way round it, is by using low-pass filter to filter out the low-frequency of the strain signal. Nevertheless, the condition monitoring system using FBG sensors was able to identify wheel defects in real time and that the FBG sensors were immune to the electromagnetic interference. Nenov et al [28] proposed an improvement of a measuring system to detect unusual wheel loading for railway vehicles in motion. The measurement device incorporates two specialised force sensors which were attached to both sides of the track. Figure 3 shows the set-up of the force sensor on one side of the track. The sensors comprised of two strain gauges which measure the tangential forces at the wheel-rail contact. Due to the power lines interference with the measured data, a notch filter was used to cancel out the 50Hz harmonics.

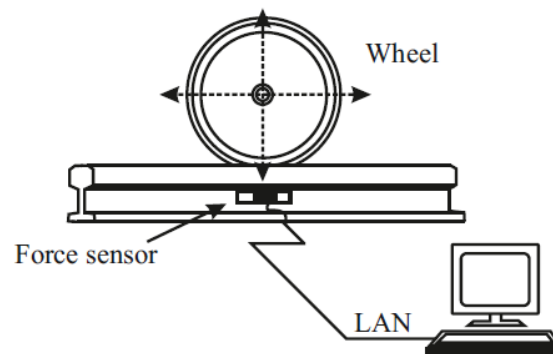

Figure 3. Wheel loading measuring device [28].

The data collected as the railway vehicle passes through the sensors was analysed and the errors in loads due to the non-perfect track were determined. The improvements made to the wheel load measuring system are:

- Adopting an appropriate notch filter to cancel the power-line interference on the signal.
- Errors in the load due to the non-perfect track section measured.

4. Conclusions

The modern intelligent railway relies on sophisticated monitoring systems to allow informed decision making on asset management actions especially in maintenance and renewals activities. An overview of the existing techniques used for condition monitoring of railway vehicle dynamics have been presented. Some of the existing condition monitoring techniques presented performs the fault detection in railway based problems (critical wheel/rail contact area, for example) by using advanced filtering, system identification and signal analysis methods. Other techniques are focussing on the fault detection and condition monitoring of vehicle suspensions by analyzing the dynamic interactions between different vehicle modes caused by component failures in the system and leading to simple but effective solutions. These approaches do not require complex mathematical models of the system and can overcome potential difficulties associated with nonlinearities and parameter variations in the system. This paper will study the feasibility of implementing these theoretical approaches in practical condition monitoring systems.

The practical monitoring of wheel defects for trains could be done through track mounted sensors and the measured data processed by an advanced calculation programme before being combined with the identification tag of a locomotive or a coach. This technique is employed by existing condition

monitoring systems and determines precisely which part of the train is faulty/damaged, and to what extent. Some of these wayside monitoring devices have encouraged the adoption of condition-based maintenance thereby saving the industry valuable time and costs. Sensors can also be mounted on the rolling stock in order to monitor the condition of the railway vehicle infrastructure. So modern rolling stock is fitted with high-capacity communication buses and multiple sensors and will result in the potential for advanced processing of collected data. This approach requires intelligent image acquisition and analysis systems capable of processing large amounts of data and various ongoing research projects are tackling this task. This paper was an attempt to collate and critically appraise the techniques used for condition monitoring of railway vehicle dynamics.

The challenge is to find the right measurement technologies, since reliable and valid measurements are a necessity for an effective condition monitoring approach. There is the question of finding relevant and correct parameters that can be measured to provide the most relevant measuring data, because the measured data must then be transformed into relevant and understandable information that can then be used as decision support in the maintenance management process. Conclusively, these are some of the corner stones that are needed to be able to arrive at a condition-based maintenance strategy.

References

- [1] Wickens A H *Fundamentals of Rail Vehicle Dynamics: Guidance and Stability* Taylor & Francis, 2003
- [2] Ward C P Weston P F Stewart E J C Li H Goodall R M Roberts C Mei T X Charles G and Dixon R Condition monitoring opportunities using vehicle-based sensors *Proceedings of the Institution of Mechanical Engineers Part F: Journal of Rail and Rapid Transit* vol 225 no 2 pp 202–218 Mar 2011
- [3] Rao B K N *Handbook of condition monitoring* Elsevier 1996
- [4] Chen J and Patton R *Robust model-based fault diagnosis for dynamic systems* Kluwer Academic Publishers 1999
- [5] Bruni S Goodall R Mei T X and Tsunashima H Control and monitoring for railway vehicle dynamics *Vehicle System Dynamics* vol 45 no 7–8 pp 743–779 2007
- [6] Kalman R A new approach to linear filtering and prediction problems *Transactions of the ASME – Journal of Basic Engineering* no 82 (Series D) pp 35–45 1960
- [7] Charles G Goodall R and Dixon R Wheel-rail profile estimation in *Railway Condition Monitoring 2006 The Institution of Engineering and Technology International Conference on 2006* pp 32 – 37
- [8] Tsunashima H and Mori H Condition monitoring of railway vehicle suspension using adaptive multiple model approach in *Control Automation and Systems (ICCAS) 2010 International Conference on 2010* pp 584 –589
- [9] Christopher W Goodall R M Dixon R Contact force estimation in the railway vehicle wheel-rail interface pp 4398–4403 2011
- [10] Xia F Cole C and Wolfs P Grey box-based inverse wagon model to predict wheel–rail contact forces from measured wagon body responses *Vehicle System Dynamics* vol 46 no 1 pp 469–479 2008
- [11] Hussain I and Mei T X Multi kalman filtering approach for estimation of wheel-rail contact conditions in *In the proceeding of the UKACC International Conference on Control 2010* Coventry UK
- [12] Fan H Wei X Jia L and Qin Y Fault detection of railway vehicle suspension systems in *Computer Science and Education (ICCSE) 2010 5th International Conference on 2010* pp 1264 –1269
- [13] Li P Goodall R Weston P Seng L C Goodman C and Roberts C Estimation of railway vehicle suspension parameters for condition monitoring *Control Engineering Practice* vol 15 no 1 pp 43–55 Jan 2007

- [14] Charles G Goodall R and Dixon R A least mean squared approach to wheel-rail profile estimation in *4th IET International Conference on Railway Condition Monitoring* 2008 vol 1
- [15] Shafiullah G M Ali A B M S Thompson A and Wolfs P J Predicting vertical acceleration of railway wagons using regression algorithms *Intelligent Transportation Systems IEEE Transactions on* vol 11 no 2 pp 290–299 Jun 2010
- [16] Oba T Yamada K Okada N and Tanifuji K Condition monitoring for shinkansen bogies based on vibration analysis *Journal of Mechanical Systems for Transportation and Logistics* vol 2 no 2 pp 133–144 2009
- [17] Belotti V Crenna F Michelini R C and Rossi G B Wheel-flat diagnostic tool via wavelet transform *Mechanical Systems and Signal Processing* vol 20 no 8 pp 1953–1966 Nov 2006
- [18] Zhang J Zhou S and Huang C A new method for the fault diagnosis of the train wheelset based on characteristic spectrum analysis in *Control Conference (CCC) 2010 29th Chinese* 2010 pp 3988–3992
- [19] Mehrpouya M and Ahmadian H Estimation of applied forces on railway vehicle wheelsets from measured vehicle responses *International Journal of Vehicle Structures & Systems* vol 1 no 4 Nov 2009
- [20] Lagneback R Evaluation of wayside condition monitoring technologies for condition-based maintenance of railway vehicles Licentiate Thesis Luleå University of Technology Department of Civil Mining and Environmental Engineering Division of Operation and Maintenance Engineering Luleå Sweden 2007
- [21] Mei T X and Li H Measurement of vehicle ground speed using bogie-based inertial sensors *Proceedings of the Institution of Mechanical Engineers Part F: Journal of Rail and Rapid Transit* vol 222 no 2 pp 107–116 Mar 2008
- [22] Monje P Aranguren G Martinez B and Casado L Using bogie-mounted sensors to measure wheel rolling and sliding in railway tracks *Proceedings of the Institution of Mechanical Engineers Part F: Journal of Rail and Rapid Transit* Dec 2011
- [23] Matsumoto A Sato Y Ohno H Tomeoka M Matsumoto K Kurihara J Ogino T Tanimoto M Kishimoto Y Sato Y and Nakai T A new measuring method of wheel–rail contact forces and related considerations *Wear* vol 265 no 9–10 pp 1518–1525 Oct 2008
- [24] Bleakely S and Senini S Autonomous time frequency analysis of wagon body accelerations in *Proceedings of the Fifth Asia Pacific Industrial Engineering and Management Systems Conference 2004* Gold Coast Australia 2004 pp 34.6.1–34.6.12
- [25] Brickle B Morgan R Smith E Brosseau J and Pinney C Identification of existing and new technologies for wheelset condition monitoring TTCI Ltd UK RSSB Report for Task T607 Jul 2008
- [26] Moynihan T W and English G W Railway safety technologies Canada Research and traffic group Jul 2007
- [27] Wei C Xin Q Chung W H Liu S Tam H and Ho S L Real-time train wheel condition monitoring by fiber bragg grating sensors *International Journal of Distributed Sensor Networks* vol 2012 pp 1–7 2012
- [28] Nenov N G Dimitrov E N Mihov G S Ruzhekov T G and Piskulev P M A study on sensors for measuring load of railway vehicle wheels in motion in *Electronics Technology 2008 ISSE '08 31st International Spring Seminar on* 2008 pp 550–555