

The Effects of Blockage on the Propagation of Acoustic Waves in the Liquid-Shell Coupled System

Wenbo Duan^{1,a}, Fengshou Gu^{2,b}, Iain Dupère^{3,c}, Shan Zhong^{3,d},
Andrew Ball^{2,e}

¹School of Mechanical, Aerospace and Civil Engineering,
The University of Manchester, Pariser Building, M13 9PL, UK

²School of Computing and Engineering, The University of Huddersfield, Queensgate, Huddersfield
HD1 3DH, UK

³School of Mechanical, Aerospace and Civil Engineering,
The University of Manchester, George Begg Building, M13 9PL, UK

^aWenbo.Duan@postgrad.manchester.ac.uk

^bf.gu@hud.ac.uk

^cIain.Dupere@manchester.ac.uk

^dshan.zhong@manchester.ac.uk

^ea.ball@hud.ac.uk

Keywords: fluid/structure coupling system; reflection and transmission characteristics; blockage detection.

Abstract. The free vibration of a fluid/structure system consisting of a cylindrical blockage submerged in a liquid enclosed by a cylindrical shell is investigated for the purpose of pipe line transportation monitoring. The wavenumbers are obtained and the reflection and transmission characteristics of these waves at the blockage interfaces are investigated theoretically. Reflection and transmission ratios are obtained in the axisymmetric mode, as functions of frequency. High order modes play an important role in the near field of the discontinuity and are taken into account.

Introduction

Pipelines are a very efficient method of transporting fluids in industry. A common problem of pipe transportation systems is associated with the occurrence of blockage. The existence of the blockage reduces the transporting efficiency of a pipeline system and endangers the safety of the system if the blockage is not cleared in a timely manner[1]. Acoustical signals are widely used for the detection of the blockage or leakage in a pipeline by various time delay estimation methods. However, the wave propagation behaviour at the blockage introduced discontinuities is poorly understood at present.

Harmonic wave propagation in the fluid-shell coupled system and in the cylinder has been studied by many authors. Fuller and Fahy [2] investigated the waves in a fluid-filled pipe by solving the coupled equations between the pipe and the fluid in the pipe. Wavenumbers in all circumferential modes are calculated, and physical interpretations of the results are presented in terms of shell motions, energy distributions, etc. Hudson et al[3, 4] comprehensively investigated the three-dimensional propagation of harmonic waves in an infinitely long circular cylinder. Fuller

investigated the reflection and transmission of flexural waves through various discontinuities in the walls of cylindrical shells[5]. The transmission loss curves are obtained for different wave modes in different circumferential orders. Muggleton et al investigated the transmission and reflection characteristics of two basic waves at a wall discontinuity in a fluid-filled piping system[6]. Simple expression for the wavenumbers of the two wave types were derived and used in the low frequency range.

In this paper, the vibration of the block, the acoustic field of the liquid and the vibration of the shell are studied separately, and the wavenumbers of the infinitely long coupling system are obtained by applying Snell's law at the coupling interfaces. Then, the effects of a finite length block are investigated. Due to the finite length of the block, acoustic waves will be reflected and transmitted at the two ends of the block. Two discontinuity interfaces can be drawn at the two ends of the block. Across the interfaces, it is required that the shell axial, radial, circumferential, and bending velocities and forces are equal because of the system equilibrium conditions. The liquid mass flow should be equal, and the normal velocity and pressure of the fluid equals the normal velocity and the stress of the block at the discontinuity interfaces.

High order modes are taken into account. Although high order modes don't transfer energy, they play an important role in the near field for the satisfaction of the boundary continuity equation.

Motion equations of the coupling system

The wavenumbers are obtained by considering the vibration of the block, the acoustic field of the liquid and the vibration of the shell separately, and combining them by applying appropriate boundary conditions at the coupling interfaces.

The co-ordinate system used in this analysis is shown in Fig. 1. The displacement components of the shell and the block are denoted by u_s, v_s, w_s , and u_b, v_b, w_b along the axial, x , circumferential, θ , and radial, r , directions respectively. Young's modulus, the Poisson ratio and mass density are denoted by E_i, ν_i, ρ_i ($i = s, b$) respectively, where the subscripts s and b refer to the shell ($i = s$) and the block ($i = b$) respectively. The radius of the block is denoted by R_1 and the radius of the middle surface of the surrounding shell is denoted by R_2 . The thickness of the shell is denoted by h .

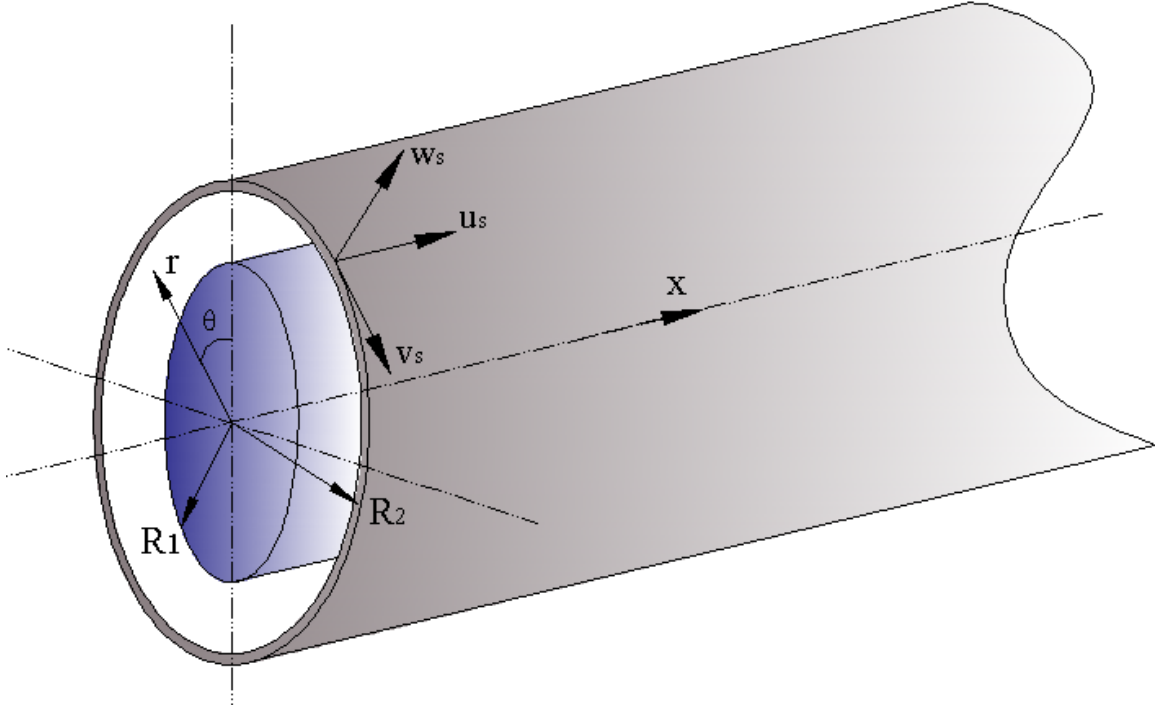

Fig. 1. A cylindrical block submerged in the liquid surround by a shell.

2.1 The vibration of the block

The displacement equation of motion of an isotropic, elastic block is given by:

$$\rho_b \frac{\partial^2 \vec{u}}{\partial t^2} = (\lambda + \mu) \nabla (\nabla \cdot \vec{u}) + \mu \nabla^2 \vec{u} \quad (1)$$

where $\vec{u} (u_b, v_b, w_b)$ is the vector displacement of the block, λ and μ are the Lamé constants of the block, and ∇^2 is the Laplace operator.

The most general solutions of Eq. (1) can be expressed in cylindrical co-ordinate as[4]:

$$\begin{aligned} u_b &= \frac{\partial \phi}{\partial x} + \frac{1}{r} \left(\frac{\partial (r H_\theta)}{\partial r} - \frac{\partial H_r}{\partial \theta} \right) \\ v_b &= \frac{1}{r} \frac{\partial \phi}{\partial \theta} + \frac{\partial H_r}{\partial x} - \frac{\partial H_x}{\partial r} \\ w_b &= \frac{\partial \phi}{\partial r} + \frac{1}{r} \frac{\partial H_x}{\partial \theta} - \frac{\partial H_\theta}{\partial x} \end{aligned} \quad (2)$$

where ϕ is a dilatational scalar potential and $\vec{H} (H_r, H_\theta, H_x)$ is an equi-voluminal (rotational) vector potential. The chosen value of \vec{H} has to satisfy the *gauge invariance* [7] of the field transformation described by Eqs. (2).

2.2 Acoustic field of the liquid

The wave equation for the liquid is described by the Helmholtz equation:

$$\nabla^2 p_f + k^2 p_f = 0 \quad (8)$$

The pressure field between the block and the shell is expressed as:

$$p_f = \left(P_{f1} J_n(k_f r) + P_{f2} Y_n(k_f r) \right) \cos(n\theta) e^{i(\omega t - kx)} \quad (9)$$

The fluid radial wavenumber k_f is related to the axial wavenumber k by

$$k_f^2 = \frac{\omega^2}{c_{(f)}^2} - k^2 \quad (10)$$

where $c_{(f)}$ is the free wavespeed in the liquid.

2.3 The vibration of the shell

The free, simple harmonic vibration of a thin-walled shell is described by Flügge's shell equations[8]:

$$\begin{aligned} & \frac{\partial^2 u_s}{\partial x^2} + \frac{1-\nu_s}{2R_2^2} \frac{\partial^2 u_s}{\partial \theta^2} - \frac{\rho_s(1-\nu_s^2)}{E_s} \ddot{u}_s + \frac{1+\nu_s}{2R_2} \frac{\partial^2 v_s}{\partial x \partial \theta} + \frac{\nu_s}{R_2} \frac{\partial w_s}{\partial x} + \beta^2 \left(\frac{1-\nu_s}{2R_2^2} \frac{\partial^2 u_s}{\partial \theta^2} - R_2 \frac{\partial^3 w_s}{\partial x^3} + \frac{1-\nu_s}{2R_2} \frac{\partial^3 w_s}{\partial x \partial \theta^2} \right) = 0 \\ & \frac{1+\nu_s}{2R_2} \frac{\partial^2 u_s}{\partial x \partial \theta} + \frac{1-\nu_s}{2} \frac{\partial^2 v_s}{\partial x^2} + \frac{1}{R_2^2} \frac{\partial^2 v_s}{\partial \theta^2} - \frac{\rho_s(1-\nu_s^2)}{E_s} \ddot{v}_s + \frac{1}{R_2^2} \frac{\partial w_s}{\partial \theta} + \beta^2 \left(\frac{3(1-\nu_s)}{2} \frac{\partial^2 v_s}{\partial x^2} - \frac{3-\nu_s}{2} \frac{\partial^3 w_s}{\partial x^2 \partial \theta} \right) = 0 \\ & \frac{\nu_s}{R_2} \frac{\partial u_s}{\partial x} + \frac{1}{R_2^2} \frac{\partial v_s}{\partial \theta} + \frac{w_s}{R_2^2} + \beta^2 \left(R_2^2 \frac{\partial^4 w_s}{\partial x^4} + 2 \frac{\partial^4 w_s}{\partial x^2 \partial \theta^2} + \frac{1}{R_2^2} \frac{\partial^4 w_s}{\partial \theta^4} \right) + \frac{\rho_s(1-\nu_s^2)}{E_s} \ddot{w}_s \\ & + \beta^2 \left(-R_2 \frac{\partial^3 u_s}{\partial x^3} + \frac{1-\nu_s}{2R_2} \frac{\partial^3 u_s}{\partial x \partial \theta^2} - \frac{3-\nu_s}{2} \frac{\partial^3 v_s}{\partial x^2 \partial \theta} + \frac{w_s}{R_2^2} + \frac{2}{R_2^2} \frac{\partial^2 w_s}{\partial \theta^2} \right) - \frac{p_f(1-\nu_s^2)}{E_s h} = 0 \end{aligned} \quad (11)$$

where β is the non-dimensional thickness parameter of the shell defined by $\beta = \sqrt{h^2 / 12R_2^2}$

The displacements of the shell wall are assumed to be:

$$\begin{aligned} u_s &= U \cos(n\theta) e^{i(\omega t - kx + \pi/2)} \\ v_s &= V \sin(n\theta) e^{i(\omega t - kx)} \\ w_s &= W \cos(n\theta) e^{i(\omega t - kx)} \end{aligned} \quad (12)$$

Substitution of Eqs. (9) and (12) into Eqs. (11) gives the motion equations of the shell.

2.4 The boundary conditions at the coupling interfaces

The boundary conditions at the inner and outer surfaces of the liquid have to be considered for the completion of the system characteristic equations. For an inviscid fluid-solid interface, the radial velocities of the fluid and the solid must be equal; however, the axial and circumferential velocities are allowed to be discontinuous. The three surface stresses must also be equal. Since the inviscid fluid cannot sustain shear stresses, the shear stresses at the inner and the outer surfaces of the liquid must be zero.

2.5 Wavenumbers of the coupling system

The system characteristic equation constitutes a relation between the axial wavenumber k , the circumferential order number n , and the wave frequency ω . For any value of circumferential order number n and wave frequency ω , the characteristic equation yields an infinite number of values of

k . The dispersion curves are obtained for the coupled system. The shell has a middle-surface diameter of 85mm and a thickness of 4mm.

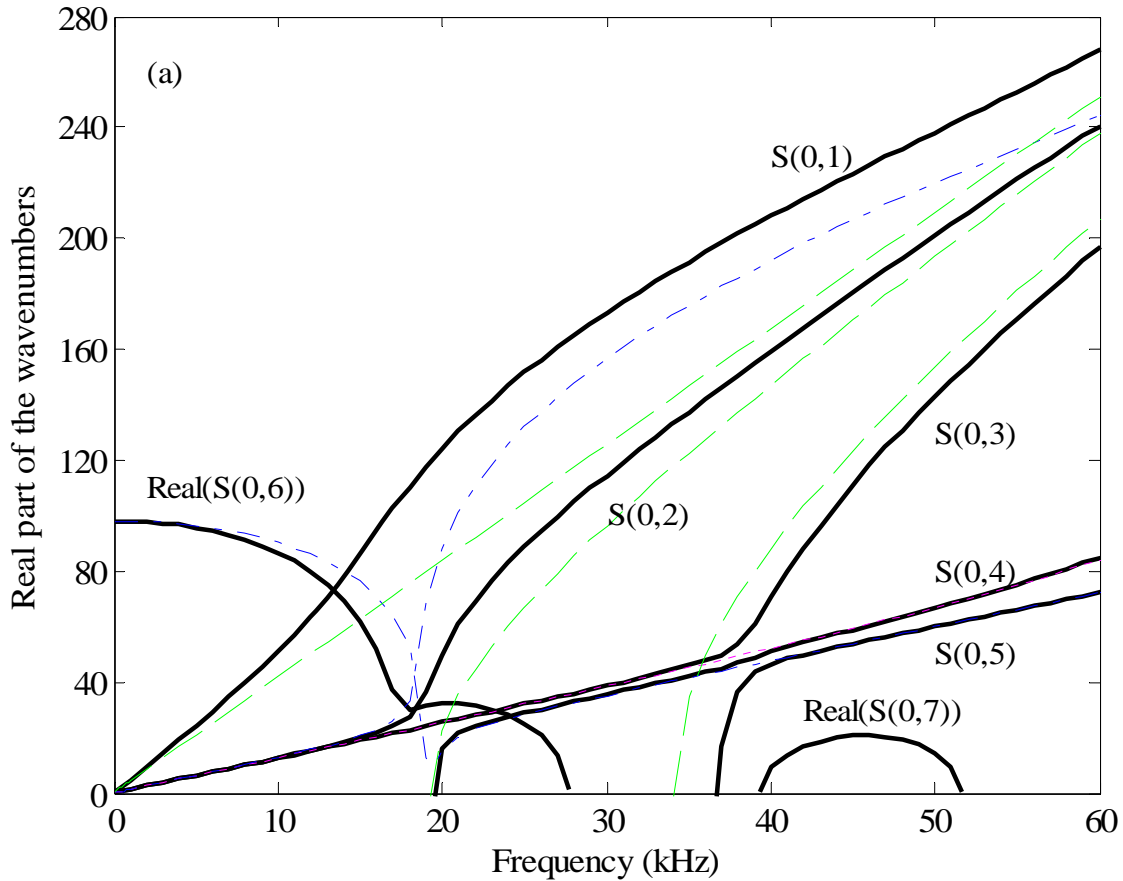

Fig. 2. (a) Wavenumbers of the travelling modes and the real part of the wavenumbers for the complex modes; (b) wavenumbers of the decaying modes and the imaginary part of the wavenumbers for the complex modes; solid line: wavenumbers of the block-liquid-shell coupled system; dashed line: wavenumbers of the liquid; dash-dotted line: wavenumbers of the shell; dotted line: wavenumbers of the block.

Fig. 2 shows the axial wavenumbers in the circumferential order $n=0$ for free waves in the coupling system with a 20mm radius block immersed in the centre of a pipe with radius 42.5mm, thickness 4mm. The axial wavenumbers represent the modes that can possibly propagate inside the coupling system. In the frequency range below 17kHz, there are three travelling modes representing the vibration of the fluid, shell and block mainly. However, as the frequency is increased, their coupling becomes stronger and the behaviour of the modes becomes extremely complicated. The wave modes for the vibration of an empty shell, the vibration of the liquid with a pressure release or a rigid boundary, the vibration of a block are also drawn on the figure for comparison. The torsional modes of the shell and the block have been omitted in the figure as it is uncoupled from all the other motions.

Wave reflection and transmission at the block interfaces

3.1 Continuity equations

The configuration of a finite length block immersed in a liquid surrounded by an infinitely long shell is shown in Fig. 3. The system is divided into three sections a, b and c. The characteristics of the wave propagation in section b are clearly different from those in sections a and c due to the inclusion of the vibration of the block. As a result, the incident wave will be partially reflected and partially transmitted at the discontinuity interfaces. Furthermore, it is assumed that an incident wave of mode order n will only produce reflected and transmitted waves with the identical mode order, since the system is symmetric with respect to its original configuration. The complex evanescent modes and the imaginary decaying modes play a very important role in the near field in order to satisfy the boundary conditions and, therefore, must be taken into consideration.

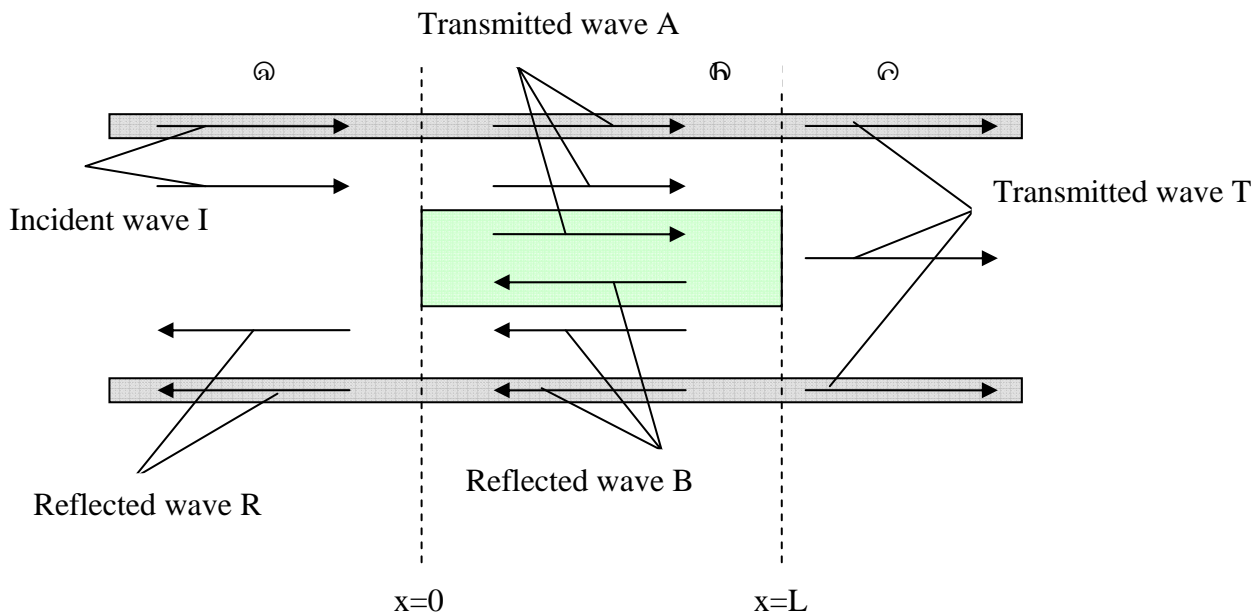

Fig. 3. Configuration of the discontinuity

The boundary conditions at each discontinuity in the shell wall are continuity of angular bending velocity, radial, axial and tangential velocity and continuity of angular bending moment, transverse shear, axial force and torsional shear. In the fluid, the boundary conditions to be satisfied are continuity of pressure at every point in the region $[R_1, R_2]$ of interfaces (1) and (2) and continuity of the volume velocity which indicates the equilibrium of the mass flow since the mean density of the water considered is assumed to be constant. In the block, the normal velocity of the block is assumed to be equal to the axial velocity of the fluid at every point in the region $[0, R_1]$ of the interfaces.

In the present paper, all the travelling modes and a finite number of near-field modes with small wavenumbers are included. The continuity points in the fluid and in the block are distributed evenly. The pressure and velocity continuity conditions are verified by comparing their values at every

point across the interfaces. If the maximum error is larger than 10%, more near-field modes and boundary conditions are taken into consideration until the continuity conditions are satisfied.

Conclusions

In this paper, the wavenumbers of a block-liquid-shell coupled system are obtained and the reflection and transmission characteristics of two basic incident waves at the blockage interfaces are investigated. All the travelling modes and a finite number of decaying modes as well as complex modes excited by the discontinuity are considered in order to satisfy the boundary continuity equations at the near field. The coupled nature of these waves was taken into consideration.

Reflection and transmission ratios are obtained in the axisymmetric mode, as functions of frequency. It is found that the reflection ratios are very low at low frequency range up to 14kHz for both the $s(0,1)$ and the $s(0,2)$ incident waves. With a long wavelength compared to the size of the block, the incident wave passes around the block. At the resonance frequency both the $s(0,1)$ and the $s(0,2)$ incident waves have very strong reflection ratios due to the coupling between the shell and the fluid. At higher frequency, the reflection ratios are dependent on the type of the incident wave as well as the new cut-on travelling modes.

- [1] P.K. Mohapatra, M.H. Chaudhry, A.A. Kassem, J. Mooloo, Detection of Partial Blockage in Single Pipelines. *Journal of Hydraulic Engineering* **132** (2006) 200-206.
- [2] C.R. Fuller, F.J. Fahy, Characteristics of wave propagation and energy distributions in cylindrical elastic shells filled with fluid. *Journal of Sound and Vibration* **81** (1982) 501-518.
- [3] G.E. Hudson, Dispersion of Elastic Waves in Solid Circular Cylinders. *Physical Review* **63** (1942) 46-51.
- [4] A.E. Armenakos, Propagation of Harmonic Waves in Composite Circular-Cylindrical Rods *The journal of the Acoustical Society of America* **47** (1970) 822-837.
- [5] C.R. Fuller, The effects of wall discontinuities on the propagation of flexural waves in cylindrical shells. *Journal of Sound and Vibration* **75** (1981) 207-228.
- [6] J.M. Muggleton, M.J. Brennan, Axisymmetric wave propagation in buried, fluid-filled pipes: effects of wall discontinuities. *Journal of Sound and Vibration* **281** (2005) 849-867.
- [7] D.C. Gazis, Three-Dimensional Investigation of the Propagation of Waves in Hollow Circular Cylinders. I. Analytical Foundation *The journal of the Acoustical Society of America* **31** (1959) 568-573.
- [8] W. Flügge, Stresses in shells. 2nd Edition ed. 1973, New York: Springer-Verlag.
- [9] A.J. Romano, P.B. Abraham, E.G. Williams, A Poynting vector formulation for thin shells and plates, and its application to structural intensity analysis and source localization. Part I Theory *Journal of the Acoustical Society of America* **87** (1990) 1166-1175.
- [10] E.G. Williams, Structural intensity in thin cylindrical shells. *Journal of the Acoustical Society of America* **89** (1991) 1615-1622.