



# University of HUDDERSFIELD

## University of Huddersfield Repository

Khin, Zu Thane Mwae

Investigation into the use of High Temperature Impact Resistant Polymers for Turbocharger Compressor Covers

### Original Citation

Khin, Zu Thane Mwae (2020) Investigation into the use of High Temperature Impact Resistant Polymers for Turbocharger Compressor Covers. Masters thesis, University of Huddersfield.

This version is available at <https://eprints.hud.ac.uk/id/eprint/35486/>

The University Repository is a digital collection of the research output of the University, available on Open Access. Copyright and Moral Rights for the items on this site are retained by the individual author and/or other copyright owners. Users may access full items free of charge; copies of full text items generally can be reproduced, displayed or performed and given to third parties in any format or medium for personal research or study, educational or not-for-profit purposes without prior permission or charge, provided:

- The authors, title and full bibliographic details is credited in any copy;
- A hyperlink and/or URL is included for the original metadata page; and
- The content is not changed in any way.

For more information, including our policy and submission procedure, please contact the Repository Team at: [E.mailbox@hud.ac.uk](mailto:E.mailbox@hud.ac.uk).

<http://eprints.hud.ac.uk/>

# Investigation into the use of High Temperature Impact Resistant Polymers for Turbocharger Compressor Covers

Zu Thane Mwae Khin  
Student ID-U1676418

A thesis submitted to the University of Huddersfield in partial fulfilment of the requirements for the degree of Master by Research

August 2020

## Table of Contents

Abstract.....	7
<b>Chapter 1</b> .....	7
<b>Introduction</b> .....	7
1.1 Literature Review.....	7
1.2 Aim and Objectives .....	8
<b>Chapter 2</b> .....	9
<b>Design Requirements for development of plastic compressor housing</b> .....	9
2.1 Product performance.....	9
2.1.1 Literature Review.....	9
2.1.2 Conceptual design.....	10
2.2 Design tools and material data .....	13
2.2.1 Material properties.....	13
2.2.4 Performance parameters.....	13
2.2.3 Loading conditions and geometrical configurations.....	13
2.3 Conclusion of design requirements for development of plastic compressor housing .....	16
<b>Chapter 3</b> .....	17
<b>Manufacturability</b> .....	17
3.1 Literature Review.....	17
3.2 Injection Moulding.....	17
3.2.1 Pros and cons of injection moulding process.....	18
3.2.2 Design aspects .....	18
3.2.3 Quality Issues .....	18
3.2.4 Economic Considerations.....	18
3.2.5 Simulation of Injection Moulding.....	19
3.2.6 Considerations of product design on the injection moulding process.....	19
3.2.7 Considerations of mould design for thermoplastics .....	21
3.1.8 Principle of Injection Moulding Machine.....	22
3.1.9 Basic units of injection moulding characteristics(Biron, 2018) .....	23
3.3 Extrusion .....	24
3.3.1 Design Aspects .....	24
3.3.2 Quality Issues .....	25
3.3.3 Economic considerations .....	25
3.3.4 Modelling of the Extrusion.....	25
3.3.5 Considerations of die design of extrusion.....	25

3.4 Compression Moulding.....	26
3.4.1 Design Aspects .....	26
3.4.2 Quality Issues .....	26
3.4.3 Economic Consideration .....	26
3.5 Conclusion of manufacturing process.....	27
<b>Chapter 4</b> .....	<b>29</b>
<b>Material Selection</b> .....	<b>29</b>
4.1 Literature Review.....	29
4.2 High performance polymers .....	29
4.2.1 Factors contributing to high performance and high temperature.....	30
4.2.2 Comparative study between High Temperature Thermoplastics and Metals .....	30
4.2.3 Classification of high temperature thermoplastic .....	31
4.2.4 Fibre Reinforcement .....	33
4.3 Selection of high-performance thermoplastic .....	33
4.3.1 Polyetheretherketone (PEEK) .....	33
4.3.2 Polyphenylene Sulphide (PPS) .....	37
4.3.3 Polyimide (PI) .....	39
4.3.4 Acrylonitrile-butadiene-styrene (ABS) .....	42
4.3.5 Polybenzimidazole (PBI).....	45
4.4 Tools of selecting materials (Pugh Screening Method).....	47
4.5 Conclusion of Selection materials .....	49
<b>Chapter 5</b> .....	<b>50</b>
<b>Cost Analysis</b> .....	<b>50</b>
5.1 Literature Review.....	50
5.2 Moulding product cost analysis .....	50
5.3 Life cycle cost analysis .....	51
5.4 Life Cycle Cost Modelling .....	52
5.5 Material cost analysis .....	53
5.6 Tolerances analysis and cost evaluation .....	53
5.7 Conclusion of Cost analysis .....	53
<b>Chapter 6</b> .....	<b>54</b>
<b>Summary of Compressor Housing Requirements</b> .....	<b>54</b>
6.1 Behaviour of compressor housing under loading conditions .....	54
6.2 Moulded-Part Design Complexity .....	56
.....	59
6.3 Conclusion of compressor housing requirements .....	59

Chapter 7 .....	60
Discussion and Future Recommendation .....	60
7.1 Final analysis of material selection .....	60
7.2 Commercial feasibility of Manufacturing Methods for compressor covers .....	66
7.3 Recommendation for future .....	66

## List of Figures

Figure 1:Relationship between car weight and CO2 emission per unit distance(g/km)(Ishikawa et al., 2018).....	10
Figure 2: Conceptual Evaluation of Plastic Design(Dunk, 2001).....	11
Figure 3: Stress-Strain behaviour of polymers(C. Miehe, 2009).....	15
Figure 4 Plastic Injection Molding Machine(Karthikeyan, 2010).....	23
Figure 5:Pyramid of Plastics Performance (SpecialCham, 2020) .....	31
Figure 6: Design for molding product cost(Asiedu & Gu, 1998).....	51
Figure 7: Life Cycle Cost Model (R.Folgado, 2010).....	52
Figure 8: Structural analysis of original Borgwarner Casing .....	55
Figure 9: Front view of variable geometry for plastic compressor design .....	57
Figure 10: Back view of variable geometry for plastic compressor design.....	57
Figure 11: Relation between Shrinkage and Thickness .....	58
Figure 12: Draft Angle.....	58
Figure 13: Ribs, Wall Thickness and draft angle of the part design.....	59
Figure 14: Strength Comparison between Aluminium Alloy and Base Polymers at room temperature .....	63
Figure 15: Comparison of strength and elongation of between Aluminium alloy and reinforced polymers .....	64
Figure 16: Dependence of Strength of aluminium alloy and polymers at elevated temperature (a) Polymer (b) Aluminium Alloy (V. I. Vettegrena, 2005).....	65

## List of Tables

Table 1-Designer Checklists(Campo, 2006b).....	11
Table 2-Material Properties .....	13
Table 3-Basic Units of injection unit characteristics(Biron, 2018) .....	23
Table 4-Basic Unit of clamping characteristics(Biron, 2018) .....	24
Table 5-Processing Methods for the production of various types of geometry(Bonten, 2019) .....	27
Table 6-Pros and Cons of polymers over metals .....	30
Table 7-Comparative properties between amorphous and crystalline thermoplastics.....	32
Table 8-Well-known properties of PEEK (data from various resources).....	34
Table 9-Summary of reinforced properties of PEEK(SpecialCham, 2020) .....	36
Table 10-Well-known properties of PPS (data from various resources) .....	37
Table 11-Summary properties of Reinforced PPS(SpecialCham, 2020).....	39
Table 12-Well-known properties of PI (data from various resources) .....	40
Table 13-Summary of reinforced properties of PI(SpecialCham, 2020).....	41
Table 14-Well-known properties of ABS (data from various resources).....	43
Table 15-Summary of reinforced properties of ABS(SpecialCham, 2020).....	44
Table 16-Well-known properties of PBI(data from various resources).....	45
Table 17-Comparative properties between selected materials and aluminium alloy .....	47
Table 18 Selecting materials by Pugh Screening method.....	48
Table 19-Comparative properties between Reinforced polymers and Aluminium Alloy .....	48
Table 20-Selecting materials by Pugh screening method .....	49
Table 21-Operation conditions for compressor (Alshammari et al., 2019) .....	56
Table 22-Experimental data of turbocharger (Alexander Mankin, 2014) .....	56
Table 23 Comparative properties of selected thermoplastic materials ... <b>Error! Bookmark not defined.</b>	
Table 24-Comparative properties between Aluminium Alloy and Based polymers (data from various resources) .....	63
Table 25-Comparative properties between reinforced polymers (data from various sources) 64	

## Lists of Equations

Equation 1- True strain, $\epsilon = \ln(1 + \epsilon_{eng})$ .....	15
Equation 2- True stress=Engineering stress x true strain (Mavrodontis, 2017).....	15
Equation 3- $Dt = D_0 + \Delta D_1 - \exp(-tt_0n)$ .....	16
Equation 4- Clamping Force=Projection area x Average Pressure .....	24
Equation 5- $K = K_d N + K_e + K_m$ .....	50

## **Acknowledgements**

First of all, I would like to express my sincere appreciation and my deep gratitude to Professor John Allport, Professor of Automotive Engineering as well as my main supervisor for allowing me to undertake this study as a partial fulfilment towards the Master by Research Degree. His kind suggestions and encouragement greatly helped me to focus on this research. This thesis would not have been possible without full support from my supervisor.

I would respectfully express my heartfelt thanks to my co-supervisor, Professor Simon Barrans for his support and suggestion in ANSYS course during implementation process. His guidance helps me understand on the application of ANSYS software.

Furthermore, I would especially like to express my thanks to my colleagues, Dr. Sidharath Sharma, research assistant of Department of Engineering and Technology for his time and support by providing design model of proposed compressor housing and Dr. Azadeh Sajedin, research assistant for giving me mental support to carry on and complete my journey whenever I am in stress.

Finally, I would like to express my heartfelt indebtedness to my family who always allows me to choose to fulfil my dream and my friends who assist and share their knowledge to me to finish this research study.

By previous findings of engineering plastics in the field of turbocharging components, the options of high-performance polymers usage are found according to its properties, designs, function and manufacturing processes.

During this research, a design observation of compressor housing is done where different types of manufacturing methods and cost are analysed. This research paper relates the investigations of selected high temperature resistant polymers based on properties and their possibility of manufacturing methods. Since manufacturing high performance polymer product is more complicated than metal components, the comparison between pros and cons of polymers and aluminium alloy will be conducted in this paper.

Due to different material options, tool of material selection is used to choose the most relevant thermoplastics polymer for the compressor housing. The objective of this research paper is to observe design aspects of turbocharger compressor housing with thermoplastics and check the commercial feasibility of its manufacturing methods.

## Chapter 1

### Introduction

---

#### 1.1 Literature Review

Regulations on carbon dioxide emissions and greenhouse gas emissions have forced the automotive industry all over the world for a bigger challenge demanding of decreasing the fuel consumption of engines and reducing the environmental impact. The effort to pursue weight reduction has become a great challenge for worldwide automotive industries. Examples of alternative ways to reduce weight are: replacing heavy materials such as high-tensile steel and aluminium alloy with lighter materials, using innovative and functional components in the system design(Alshammari, Xypolitas, & Pesyridis, 2019).

Engineering thermoplastic materials provide consistent strength and stiffness, and outstanding impact performance, excellent creep resistance for metal replacement. They also have a better corrosion resistance than metal. Despite the fact that the lighter materials can reduce weights, they cannot be replaced in some applications which requires electrical conducting property, high strength and rigidity at elevated temperature. Therefore, manufacturing and new product development are more complicated than metal components (Dupont, 2020)

Turbocharging system are used in most of automotive engines today. They increase the energy efficiency of the engine. (Alshammari et al., 2019).Such systems have been used for a long time in the boosting of automotive Engines and each of the elements that make up the turbocharger has been gradually improved.

According to the high operating temperature, turbochargers are subjected to a hostile environment. Therefore, high temperature properties should be enhanced in order to use the materials at high temperature with increasing engine performance. For example, an austenitic cast steel, which has an excellent strengths and thermal fatigue properties above a typical exhaust-gas temperature of 950 degree C, have been used as turbocharger turbine housing

materials.(Yoo et al., 2019). However, a great amount of Ni makes cost of the steel more expensive (Wei Guo, 2014).

Polymeric materials have long been utilized in high temperature and high heat flux environments. According to the success in the field of synthetic polymer chemistry, polymers have increasingly met the high-performance challenge. As increasingly more stable polymers have become available, there is a dramatic increase of potential engineering applications for these materials (Rogers, 1995).

It is one object to provide a housing part, a housing for a radial flow compressor and a method for the manufacturing of the housing, whereby the housing to be created can also withstand the high impermeable requirements of such a compressor a simple production and a precise dimensioning of the housing (Setyowati & Pandelaki, 2018).

## **1.2 Aim and Objectives**

The aim of this project is the investigation of data analysis-based project for the design of polymer compressor housing by the improved understanding between polymer structure.

The main objectives of the projects are to observe the available materials based on the physical and mechanical properties and to identify manufacturing methods for the compressor impellers housing in automotive industry. The material and manufacturing method selection will base only on the independent research and literature research.

## Chapter 2

### Design Requirements for development of plastic compressor housing

---

A designated product can be distinguished into three different elements such as components, joints and in process structures. These elements of a product provide a function or feature of the product (Pfeifer, 2009). Furthermore, the product elements within a product should be developed to satisfy all of the product requirements such as the performance, reliability and cost, which mainly depend on the physical construction and the properties of materials.

When designing components with complexity of materials, it is essential to understand the variety of properties and the processing methods to obtain optimum results of the end product. Therefore, before a design analysis is done, it is important to understand what the requirements of the plastic components are and what circumstances they will operate.

#### Design Requirement

- Product Performance,
- Manufacturability
- Material Selection and
- Costs factor

### 2.1 Product performance

#### 2.1.1 Literature Review

Global warming has forced the regulatory authorities around the world to establish strict regulations on Carbon dioxide emissions and other greenhouse gas emissions. One of the regulations, so-called EURO 6 regulation, in which vehicles exceeding 95g/km of CO<sub>2</sub> emission will be charged a high tax from 2020 (Ishikawa et al., 2018). Due to high pressure of this regulation, automobile manufacturing industries have been trying to develop new technologies for carbon footprint reduction. The following figure shows that 100 kg weight saving in each automotive reduces 20 g/km of CO<sub>2</sub> emission.

Regarding to reducing CO<sub>2</sub> emissions, the weight reduction of automotive structures has become a great challenge for worldwide car manufacturers. Among several alternatives to pursue lighter-weight car, employment of lighter materials (high-tensile steel, aluminium alloy, composite, etc.) and transformation in the car system design with great functionality of components are the most effective ways of decreasing CO<sub>2</sub> emission.

This leads to designing more power and more sustainable products for reducing the environmental impact from automotive industries (Alshammari et al., 2019).

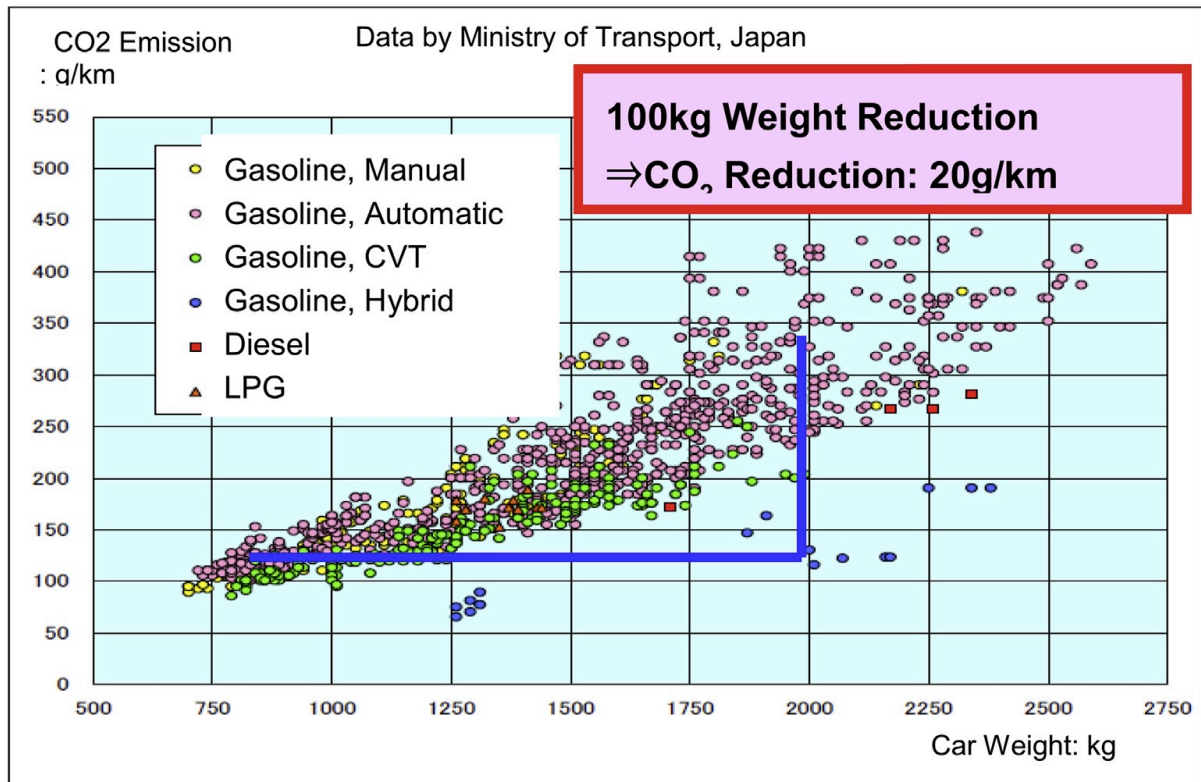

Figure 1: Relationship between car weight and CO<sub>2</sub> emission per unit distance(g/km)(Ishikawa et al., 2018)

### 2.1.2 Conceptual design

In term of physical construction of the product, it refers the shape and dimensions of the product and affects its characteristics and behaviours from the distribution of mechanical loads along the product element. While designing a product with a relatively complexity of material like polymer, it is very important to evaluate a design concept to satisfy the design requirements. The following figure explains how the design concept is evaluated into four main categories such as product, process, time and cost.

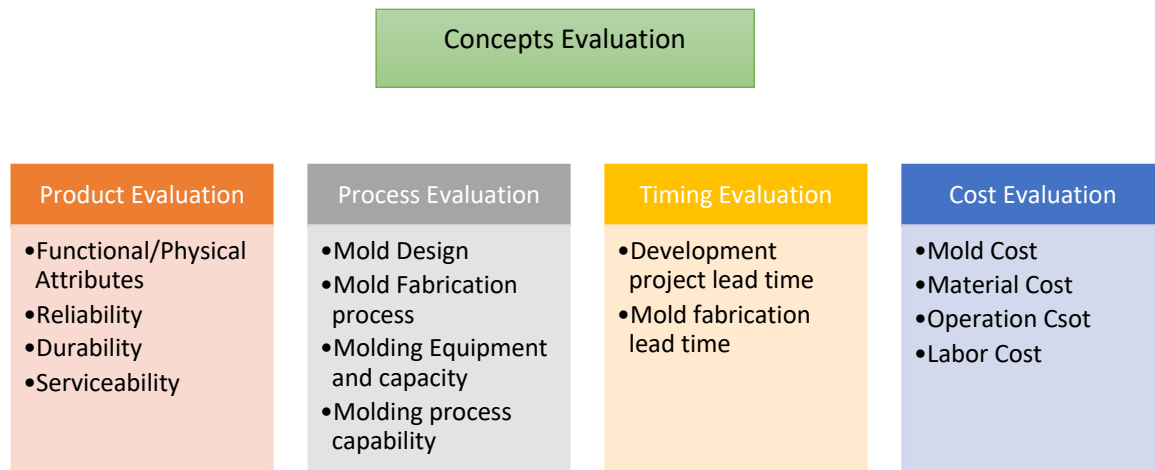

Figure 2: Conceptual Evaluation of Plastic Design(Dunk, 2001)

Depending on various industries, there can be a large difference between the properties, processing methods, and application of materials. The properties from various groups of polymeric materials should be compared by the product designer because each material has its specific applications, market, and different manufacturing processes required. The following table is shown that the requirements needs to be considered for a product as a product designer. The requirements are listed in details into five main categories such as general considerations, environmental requirements, design factor, quality control tests requirements, resin processing characteristics.

Table 1-Designer Checklists(Campo, 2006b)

<p>General Considerations</p>	<ul style="list-style-type: none"> <li>• Performance requirements (Structural, loading cycle, aesthetic, etc.)</li> <li>• Multifunction design</li> <li>• Product design for assembly</li> <li>• Structural load (static, dynamic. Cyclic, impact, etc.)</li> <li>• Product tolerance specifications</li> <li>• Life of product</li> <li>• Resin selection based on performance of similar applications and end use</li> <li>• Product design for assembly process</li> <li>• Quality of product vs process</li> <li>• Secondary operations</li> <li>• Packaging and shipping</li> </ul>
-------------------------------	--

Table 1 (Continued)

<p>Environmental requirement</p>	<ul style="list-style-type: none"> <li>• Type, frequency, direction of loads</li> <li>• Working stress selected (tensile, compression, flexural, combination)</li> <li>• Strain percentage selected</li> <li>• Load deformation</li> <li>• Correlating the test results to end use environment conditions</li> <li>• Safety factor</li> <li>• Design product for efficient moulding</li> </ul>
<p>Design Factors</p>	<ul style="list-style-type: none"> <li>• End use temperature</li> <li>• Time, weather, strain and stress cracks</li> <li>• Others (chemical, lubricants, water, humidity, pollution, gasoline, etc.)</li> </ul>
<p>Quality control tests required</p>	<ul style="list-style-type: none"> <li>• Tension</li> <li>• Compression</li> <li>• Flexural</li> <li>• Impact</li> <li>• Torsion, fatigue</li> <li>• Creep</li> <li>• Chemical resistance</li> <li>• Continuous service temperature</li> <li>• Temperature index</li> <li>• Final product approvals</li> </ul>
<p>Resin Processing characteristics</p>	<ul style="list-style-type: none"> <li>• Viscosity and crystallization</li> <li>• Difficulties in moulding the resin</li> <li>• Melt and mould temperature</li> <li>• Sensitivity to thermal degradation</li> <li>• Directional layout of reinforcements</li> <li>• Mould shrinkage control</li> <li>• Moulding problems</li> <li>• Material handling</li> <li>• Percentage of reground (runners and rejected moulded parts)</li> <li>• Drying resin and reground material</li> <li>• Prototype moulding the product (resin behaviour unknown)</li> </ul>

## 2.2 Design tools and material data

According to the relative complexity of polymer behaviour compared with metals which is mostly used for engineering design application, it is necessary to fully understand designing with polymers and to have sufficient knowledge about the mechanical properties of polymers (Gerdeen Pe & Rorrer Pe, 2011).

During selecting a systematic procedure of complex design such as compressor housing, the material selection includes as one of the most difficult parts in the designing procedure. To establish a material selection procedure, it would be easy to understand if necessary data are divided into four main categories:

- Material Properties
- Performance Parameters
- Loading conditions and geometrical configurations

### 2.2.1 Material properties

The material properties will be considered based on the particular design application. In the case of design complexity of polymer compressor housing design, the fundamental material properties will be under consideration. Cost of material is always important in selection procedure and will be measured by the price per unit weight,  $P$ . These listed properties below are important in the case of application involving high temperature changes.

*Table 2-Material Properties*

1. Density	$\rho$
2. Specific gravity	$\gamma$
3. Ultimate Strength	$S_u$
4. Yield Strength	$S_y$
5. Ultimate strain	$\epsilon$
6. Creep rupture strength and critical time	$S_c, t_c$
7. Creep strain limit	$\epsilon_c$
8. Modulus of elasticity	$E$
9. Flexural strength	$\sigma$
10. Thermal conductivity	$k$
11. Coefficient of thermal expansion	$\alpha$
12. Endurance limit in fatigue	$S_e$

### 2.2.4 Performance parameters

There are some ways to measure the performance of a design. In the design of compressor housing, the following performance parameters are considered such as material parameters, process parameters and geometrical parameters.

### 2.2.3 Loading conditions and geometrical configurations

According to plastic non-Linear Considerations, selected polymeric materials will be discussed in three categories such as non-linear materials and their analysis in the FEA method.

### ***2.2.3.1 Non-Linear Materials***

Unlike metals, polymers have dramatically different material properties depending on the direction, type, and speed of the loading conditions (Al-Rousan, Shbeeb, & Al-Masri, 2016). Polymeric materials, certain metals, all thermoplastic and thermoset elastomers are classified as nonlinear materials due to the fact that they cannot be fully recovered to its initial dimensions once load is removed (Tres, 2017). It means that these materials do not obey Hooke's law because the linear approximation of the stress-strain curve provides a significant error in the analysis.

Polymer shows viscoelastic behaviour resulting both elastic and plastic deformations when an external load is applied. Nonlinear materials have an ability to absorb short duration impact loads at higher rate. Most plastic components designers carry out a full non-linear characterization of the structural behaviour of a proposed design before releasing next manufacturing process. This intends to eliminate many failures, unanticipated part performance, and part functionality in a wide range of manufacturing tolerances.

### ***2.2.3.2 FEA Method Application***

As the structural analysis of nonlinear materials in the FEA method are complicated, the following mechanical properties are essential to do the analysis of nonlinear geometry.

### ***2.2.3.3 Stress-Strain behaviour***

Product design considers the stress response of the material based on Hooke's law which states that the strain is directly proportional to the stress for an elastic material. Unfortunately, Hooke's law does not accurately reflect the stress-strain behaviour of plastic components because plastic do not exhibit basic elastic behaviour. This can provide a poor guide to successful design (Sidney Levy, 1984). Besides, polymers possess a very complex nonlinear behaviour depending on external loads such as strain, temperature and structural parameter like crystallinity degree, molecular weights and cross-linking.

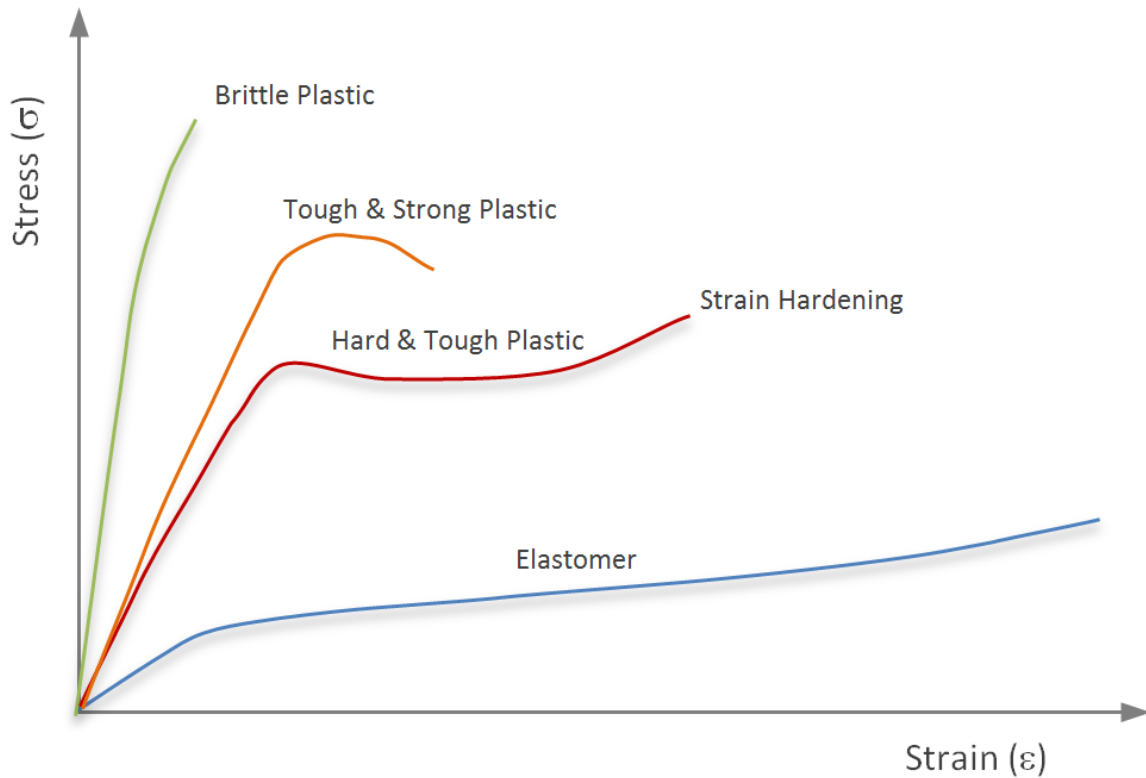

Figure 3: Stress-Strain behaviour of polymers(C. Miehe, 2009)

Because polymeric material is significantly influenced by temperature at a variable amount of time, it needs to be considered the effects of creep and nonlinear stress-strain relationships. In a variety of finite element analyses where nonlinear material analysis is carried out, both true stress and true strain are required to input as engineering material data. The logarithmic plastic strain can be given with the equation as:

$$\text{True strain, } \varepsilon = \ln(1 + \varepsilon_{\text{eng}}) \quad \text{Equation 1}$$

$$\text{True stress} = \text{Engineering stress} \times e^{\text{true strain}} \quad (\text{Mavrodontis, 2017}) \quad \text{Equation 2}$$

#### 2.2.3.4 Temperature

Once the temperature has exceeded the glass transition temperature, the polymeric material can suddenly change its mechanical behaviour.

#### 2.2.3.5 Creep and relaxation of polymer

A nonlinear viscoelastic model can be predicted as the time-dependent deformation of a polymer under a multiaxial stress. This explains that the mechanical properties of polymers can vary with time under an applied load, and the tensile creep compliances over a suitable time range and at different stress levels over which creep behaviour is nonlinear (Dean, McCartney, Mera, & Urquhart, 2011). Therefore, this needs to be considered in the designing procedure of a component in the finite element systems.

The phenomena of creep and relaxation in the thermoplastic materials are main concern for the plastic parts, in which creep can take place even at low loads and low temperature. Various mathematical functions have been developed to measure creep compliance. For semi-crystalline polymers, the function is taken as:

$$D(t) = D_0 + \Delta D \left[ 1 - \exp - \left( \frac{t}{t_0} \right)^n \right] \quad \text{Equation 3}$$

Here,  $D(t)$  is the time-dependent tensile compliance and  $D_0$  is the instantaneous compliance and is equal to the inverse of the tensile modulus in the limit of short times under load. Parameters  $t_0$  and  $n$  are analogous to the parameters  $t_m$  and  $Y$  respectively.  $\Delta D$  Is the magnitude of the relaxation process such that  $D_0 + \Delta D$  is the compliance in the limit of long times when the relaxation process is complete.

#### **2.2.3.6 Fracture toughness**

In the case of designing part with engineering plastics, the effect of elevated stress is therefore to increase molecular mobility, and therefore the polymer creeps faster. The determination of nonlinear shear behaviour and fracture toughness of materials are also necessary parameters in structural analysis of polymeric components in order to benefits in operating costs and performance (Tan & Falzon, 2016). Notched Izod impact test can be performed according to ISO-180 to achieve toughness value of different polymers by ASTM D256 test method (Yang et al., 2011).

### **2.3 Conclusion of design requirements for development of plastic compressor housing**

The project will be performed based on the conceptual design evaluations, which are process evaluation, product material evaluation, time evaluation as well as cost analysis in the following stages of projects. Mainly, the material selection and manufacturing processes will be analysed in detail according to the essential requirements which are suitable for the plastic moulding products.

## **Chapter 3**

### **Manufacturability**

---

#### **3.1 Literature Review**

Manufacturing of plastic parts can generally be categorized into the four following stages (Osswald & Hernández-Ortiz, 2017). First, shaping processes which includes transforming a polymer pellet, powder or resin into a final product or into a preform using moulding and extrusions processes such as injection, compression moulding, rotational moulding, and so on. The next stage of manufacturing is secondary shaping processes which involves converting a preform polymers such as a parison or sheet into a final product using processes such as thermoforming or blow moulding, etc. Thirdly, material removal processes which performs material removal from the mould by means of machining operations, stamping, laser drilling and so on. Last but not least, joining processes which bring two or more parts physically or by bonding or welding operations.

In this stage, shaping and forming processes take place by heating thermoplastic above glass transition or melting temperatures and freezing into the required final product shape by reducing the temperature. The common used processes for manufacturing parts from thermoplastics are listed below: (1) Injection Moulding, (2) Compression Moulding, (3) Continuous Extrusion, (4) Resin Transfer Moulding, (5) Blow Moulding, and (6) Rotational Moulding

However, we will discuss mainly about injection moulding process in details, which is the most suitable processes among other processing methods for complex product design structure. The facts that we chose injection moulding process will be furthered explained in this chapter.

#### **3.2 Injection Moulding**

One of the widely used moulding processes for thermoplastics is injection moulding process. The thermoplastic injection moulding process includes the usage of mould necessary to produce the end product. Therefore, it is essential to understand the detailed product design, thermoplastic resin, the injection moulding process, and the technical information which is required in building the mould of end product (Campo, 2006a).

The process includes melting thermoplastic, injecting it into the designated mould cavity and then cooled to solidify it. Depending on several shape and application of the product, there are different injection moulding processes such as reaction injection moulding, Microinjection moulding, gas-assisted injection moulding, powder injection moulding.

In this section, only standard injection moulding process will be discussed regarding classification of thermoplastic injection moulds, design aspects, quality issues, and economic considerations (Swift, 2013).

### **3.2.1 Pros and cons of injection moulding process**

- Allows total automation of the process and high output rates
- Having the highest mould and press prices, but the cheapest labour costs
- Suitable for high volume production
- Gives a good finish of whole surface of the part
- Difficulty of optimization of the moulding parameters, and prediction of part warpage and shrinkage
- Apart from particular cases of resins filled with fibres, the parts are isotropic if there is no residual constraints
- The mould size and machinery performances limit the part sizes
- Shot capacities cover a large range, for example, a few grams up to more than 100 kg

### **3.2.2 Design aspects**

During designing injected moulding components, there are different aspects approaching to detailed design. In the injection moulding method, it is possible to allow very complex shapes and very complicated detail which is included with holes, inserts, threads, lettering, colour, bosses and minor undercuts. However, narrow-necked container design is not recommended and also uniform section thickness should be maintained. Regarding of variation in thickness, it cannot be exceeded in the ratio of 2:1. Draft angle ranges and parting line are also essential for the purpose of avoiding placement across critical dimensions. Depending on the section depth, draft angle ranges from less than  $0.25^\circ$  to  $4^\circ$  (Bonten, 2019).

### **3.2.3 Quality Issues**

Using injection moulding method can be difficult for thick sections design (Baird & Collias, 2014). Design of running and gating system should be given full attention due to multiple cavities are used to fill die complete. To achieve the qualify products, there are critical processes, such as material control, mould temperature, injection pressure, speed, resin condition, dwell and cooling times, which needed to be given full attention on. Excessive feed in the mould can create flash, which can be prevented by adequate clamping force. Surface roughness can be the result of a function of die condition. In addition, dimensional allowances should be given  $\pm 0.1\text{mm}$  across the parting line.

### **3.2.4 Economic Considerations**

There are some basic economic considerations for using injection moulding process. Based on product size, high production rates will be approximately 1/60min despite complex dies can take many weeks for manufacturing. Even though equipment and tooling costs are high due to dies made from hardened tool steel, finishing costs are low. Gates and runners can be reused following lower material losses. In addition, trimming is needed to remove gates and runners. There is limited flexibility by dedicated dies because of die changeover and machine set-up times(Baird & Collias, 2014).

### **3.2.5 Simulation of Injection Moulding**

The design of injection moulding tooling is a complex process because tooling includes multiple cavities and several gates. Therefore, simulation needs to be capable in order to predict layout of cavity and runner, injection pressure, gate location, weld line positions, and cooling time. Besides, molecular orientation, morphology, residual stresses, warpage, and shrinkage are desirable to predict in the injection moulding simulation process (Baird & Collias, 2014).

### **3.2.6 Considerations of product design on the injection moulding process**

The product design is depending on the functional requirements such as moldability, productivity, and performance (Zhou, 2013). During designing process of injection moulded thermoplastic parts, the product designer must consider about some part configurations which can lead potential problems. Basic design requirements include wall thickness, Draft walls, parting plane, sharp corners, bosses and cored holes, and ribs, etc.

#### ***3.2.6.1 Wall thickness***

Injection moulding prefers uniform wall thickness. Thick walls will cool slower than thin walls and shrink away from the mould after the gates are frozen, resulting in sink marks, residual thermal stresses, warpage, part distortion, poor surface finish, and structural defects. Unavoidable thick-to-thin wall transition must be as gradual as possible and the ratio of thickness should be no more than 3:1. Dimension of wall thickness- Inside radius must be at least half of the primary wall thickness in the meanwhile outside radius should be the inside radius plus the wall thickness. Recommended wall thickness ranges from 0.8 to 4.8 mm related to material and process. The thinner wall thickness, the lower material costs and cooling time although the wall should be thick enough to resist ejection pin forces.

#### ***3.2.6.2 Draft***

Lack of draft in the thermoplastic mould can lead parts will stick to the mould cavity surface, resulting drag marks and surface finishing defects(Zhou, 2013). Draft angles are generally equal for both male and female parts of mould in order to maintain uniform wall thickness and to decrease adhesion of warm parts to the cavity. Due to the fact that it is desired for having the parts remain in the cavity when the mould is opened, knockout pins or slight undercuts should be added on the side of mould cavity in the case of little or no draft angle. Recommended draft angle for unreinforced thermoplastics is at least  $1/2^\circ$  and  $1.5^\circ$  for glass reinforced resins, which have lower moulding shrinkage.

#### ***3.2.6.3 Parting plane***

To minimize mould-making costs, the parting plane must be a single flat surface and make sure optimum sealing against injection pressures, simplify the venting air. The parting plane must be on the largest part dimension and at a right angle to the direction of mould closing and opening. In a proper operation, flash can be 0.02-0.03mm thick and it is easiest to deflash from a sharp corner. Recommend to have a small radius at the outer corner of the part.

#### **3.2.6.4 Sharp Corners**

On the thermoplastic part or within the mould cavity, internal or external sharp corners can create high stress concentrations, and can lead causing of failure in injection moulded thermoplastic parts. A radius from 0.25-0.31 mm is enough to break a sharp corner. Recommend to reduce the radii and polish the surface area for unavoidable sharp corner. Internal and external radii should be proportional to maintain uniform wall thickness. For highly reinforced parts or compression moulded composites, more generous radii are required in order to help the resin flow through the fibres and avoid appearance problems.

#### **3.2.6.5 Bosses and Cored Holes**

Bosses provide cored holes, which are used for mechanical fastener locations, distributes bearing loads and fastener loads to the main structure(Zhou, 2013). The boss height should not exceed twice the boss diameter because high bosses can trap air. The height of the unsupported core must not exceed four times the thickness of core base. However, cores with greater height should be supported via using core inserts to decrease mould failure and to get ease of repair. Avoid to use long and narrow cores due to the fact that the injection pressure will deflect the cores during the moulding process and causing the parting line opening and resulting early failure of the mould core insert (Karthikeyan, 2010).

#### **3.2.6.6 Threads**

Internal threads, undercuts and protrusions are needed for the collapsible core, which is a major breakthrough in injection moulding thermoplastics products. Especially for conventional internal threaded products, the automatic operation of the collapsible core is more likely to reduce the injection moulding cycle up to 30%.

-There are several types of standard thread developed for thermoplastic applications. Here are most useful thread designs:

- a) Buttress Threads, which have standard root radius ranging from 0.035 to 0.070 x pitch, are the preferred type of threads for thermoplastic applications.
- b) British Association Standard thread, which is recommended by the British Standards Institute for all screws smaller than 0.25inch diameter, is suited in thermoplastic applications according to its thread face angle of 47.5 degree and its large root radius of 0.180 x pitch.
- c) Whitworth thread is a very useful thread design, which reduces the stress concentration effect, and has a radius of 0.137 x pitch at the root of each thread(Karthikeyan, 2010).

#### **3.2.6.7 Structural Ribs Design**

Ribs are used to provide the stability of the walls. Ribs can also be used not only to increase melt flow into the section, such as a corner or a large boss, but also to improve flexural stiffness of the part. When the wall thickness  $W$  is increased, the section modulus increases in proportion to  $W^2$ . It means that fourfold increase in stiffness can double up the weight. So, it can also increase the material utilization and processing costs dramatically. The substituting with reinforcing ribs is essential to increase stiffness at this point. Adding stiffness can not only minimize deflection and creep strain but also increase natural frequency and impact resistance.

### **3.2.6.8 Gate**

The gate is used as a thermos-valve between the runner and the cavity and the location of gates determines the mould shrinkage, the melt flow, part dimension, warpage, and weld line strength(Karthikeyan, 2010). The melt injection speed, pressure, and temperature rise the temperature around the gate area. The hot gate permits the melt to enter the cavity without shearing off the polymer and the gate itself cools off when the melt stops moving.

### **3.2.7 Considerations of mould design for thermoplastics**

In the designing of thermoplastic injection mould, the main consideration of mould designs is: mould type, size, number of cavities, tolerances, runner layout, gating, venting, parting line, ejection system, surface finishing, steel hardness, and mould cooling system. There are many rules for designing moulds. The geometrical design of a thermoplastic injection mould, type of resin, the dimensional tolerances of the product, the part quality, and the volume of part production can have a great effect on the selection of mould material(Campo, 2006a). The basic considerations of mould design such as mould cavity, parting plane, runner system, cooling system, ejector system, and mould venting will be discussed in general in the following section.

#### **3.2.7.1 Mould Cavity**

As the melt is filled into the sections of the cavity, mould cavity should be built with dimensional allowances because of the shrinkage of the plastic. Usually, mould and cavity inserts are made from strong materials like steel as the high viscosity of the thermoplastic material needs high injection pressures. The number of cavities in a mould is decided by the economic restriction (part production costs and delivery date) and technical criteria (the size of each cavity and the maximum mould dimension, the moulding machine equipment and the part quality demands). Preferred number of cavities in building mould are:2,3,4,6,8,12,16,24,32,48,64,96, and 128 and it is for making designing and dimensioning easier.

#### **3.2.7.2 Parting Plane**

The separation plane between two mould halves called parting plane is used for ease of mould manufacturing. The parting line is normally at the widest circumference of the product for ejection of part from mould. Poorly finished parting line can result unsightly sharp projection or flash, which need to be removed after demoulding.

#### **3.2.7.3 Runner System**

It is essential to have a good design with a balanced runner system in a mould for filling the melt into the cavities with lower cycle time and best dimensional integrity to the mould product. Apart from the space of cavity in a mould, the runner system is comprised of three items:

- Sprue, the flow passages where the machine nozzle reaches the mould
- Runners, which lets the plastic melt flow into all sections of cavities, and
- Gates, the opening directing from the runner into the hollow cavities.

Based on the shape of runners, long and thin or half-moon runners need high injection pressure for the fact that the mould does not cool off early enough for causing part failure. Long and thick runners need more amount to reshape and decrease moulding efficiency.

There are two common runners, hot and cold runners, which are in use based on different processing requirements. With a cold runner, the melt moving from the sprue to the gate solidifies by the mould cooling action. With a hot runner, the melt flow will remain hot by heating the sprue to the gate with heater bands or by insulating from the cold cavity.

#### **3.2.7.4 Cooling system**

A good cooling system is very important for removing heat efficiently in injection moulding. A mould cooling system is playing essential roles for controlling dimensional integrity, surface finishing, warpage, weld line strength, physical properties and cycle time (Agazzi, Sobotka, LeGoff, & Jarny, 2013).

A common used cooling system includes the following parts such as temperature controlling unit, pump, supply manifold, hoses and collection manifold.

To design the best cooling layout, the designer can have an assistance from computer program. There are basic rules for setting up a cooling system. First, heat flow is only effective by moving coolant, which is same flow rate for all cavities and cores. Secondly, amount of removed heat depends on the coolant flow rate and it needs to have faster coolant flows, which needs to be ensured by calculated the cross sections of the channel sizes for all channels. Third, the coolant should have a turbulent flow pattern rather than in a laminar flow pattern. Last but not least, heavy sections of the product can cause potential shrinkage and sink marks and thin and slender core pins, blades, and sleeves should be considered carefully.

### **3.1.8 Principle of Injection Moulding Machine**

Injection moulding involves a wide variety of variables such as profile of cylinder temperature, mould temperature, injection rate, holding pressure, back pressure and speed of rotation of the screw (Gilbert, 2017)

Inside the injection-moulding machines, it can be characterized by clamping system type, shot capacity, plasticizing capacity, screw sizes Length/Diameter, maximum injection pressure and maximum mould sizes.

It consists of three main parts:

- An extruder with a heating device for melting resin. Depending on the injected material, the screw design and the temperature can vary.
- A ram system which allows dosed material under high pressure into the mould.
- A mould with a cooling device, which permits cooling of thermoplastic.

The following tables show some examples of injection and clamping unit characteristics.

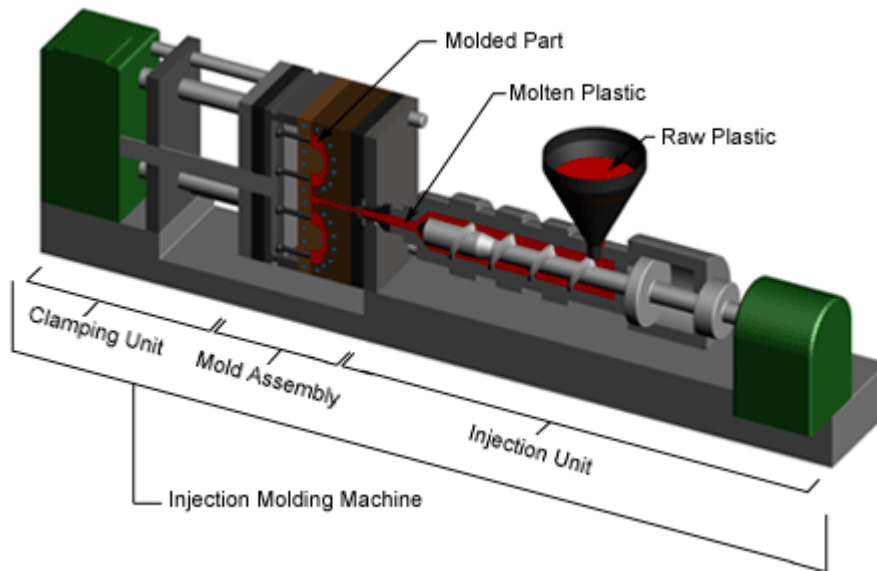

Figure 4 Plastic Injection Moulding Machine(Karthikeyan, 2010)

### 3.1.9 Basic units of injection moulding characteristics(Biron, 2018)

The basic characteristics of plastic injection moulding is meant to fill the molten polymer material in a closed mould with high pressure. The plasticizing rate is important because it will show the amount of time which is needed to melt the resin. Therefore, it is appropriate to have 130-190 g/s plasticizing rate with the injection pressure of 1750 Bar for the case of estimated plastic compressor housing design. The following basic units are for the plastic injection moulding depending on different parameter of moulding material and different shape of products.

Table 3-Basic Units of injection unit characteristics(Biron, 2018)

Injection pressure(bar)	Shot capacity(cm <sup>3</sup> )	Screw drive(rpm)	Plasticizing rate max(g/s)
2600	13	375/470	2
2400	23	375/470	4
1600	34	375/470	7
2500	50	480	12
2000	75	480	18
1500	100	480	24
1900	380	330-450	35-45
2400	770	200-300	50-70
1800	1050	200-300	70-100
2200	1500	200/280	100-150
1750	2000	200/280	130-190
1400	2400	200/280	160-230
1800	10,000	80-110	190-260
1500	12,000	80-110	250-350
1700	38,000	65	580

The average pressure within the mould added to the projection area is called the clamping force. When the mould is closed, the moulding material will be cooled off and solidified in the mould cavity. So, the mould will not be opened by the maximum clamping force when the injection is started. The clamping force is always different according to the shape of the forming materials and the shape of the product types. Generally, the mould can withstand the pressure of 392 bar and the clamping force can be calculated based on the parameter of materials.

$$\text{Clamping Force} = \text{Projection area} \times \text{Average Pressure}$$

Equation 4

In the case of plastic compressor housing moulding based on the difference between the parameters such as PEEK and PPS, the clamping force, which the mould needs to withstand, is between 300 and 500 for the product with high precision.

Table 4-Basic Unit of clamping characteristics(Biron, 2018)

Clamping force(kN)	Size of mould platens(mm)	Mould height min(mm)
300-500	540x540	200
650-800	600x600	250
1100	850x875	250
1800	900x900	350
2800	1000x1000	330
3800	1300x1200	380
4000	2000x1800	700
20,000	2600x2300	1000-1700
40,000	3300x2900	1100-2000
54,000	3800x3200	1400-2300

### 3.3 Extrusion

Extrusion is another popular manufacturing process among thermoplastic processing. It is feeding the raw material from a hopper into a heated barrel and pushing along a screw-type feeder, where plastic pellets are compressed. Then the molten polymer is forced into a die of the required shape, where the temperature is lower at the exit of the die. Raw plastic materials used in extrusion are in the form of pellet, granular or powder.

Extrusion process can be used not only for thermoplastics but also for some thermosets and elastomers. Most common used extruders are equipped with a single screw, but two or more screw extruders are also available. Coaxial fibres or tubes and multi-component sheets are produced. Moreover, plastic coatings can be manufactured by combining metal wire, strips and sections with extrusion process in an offset die (Osswald & Hernández-Ortiz, 2017).

#### 3.3.1 Design Aspects

There are some design aspects of extrusion method for thermoplastic polymers. This manufacturing process is suitable for long products with uniform cross-sections, which can be extremely intricate and also solid forms like re-entrant angles with closed or open sections.

Section profile designed to improve assembly efficiency by integrating part consolidation features. No draft angle is required. One of the difficulties of using this method is that secondary operations are needed for the product design which is included with grooves, holes and inserts, which are not parallel to the axis of extrusion.

### **3.3.2 Quality Issues**

Due to shrinkage and distortion, cooling rate and uniformity are important for dimensional control. Cause the alignment of molecules in solids. Surface roughness is good to excellent. Trapped gases have a detrimental effect on both the output and the quality of the extrusion. Die swell, where the extruded product has increasing size at the exit of the die, may be resulted by increasing haul-off rate compared with extrusion rate, decreasing extrusion rate, increasing the length of the die land, decreasing the melt temperature (Bonten, 2019).

### **3.3.3 Economic considerations**

There are some basic economic considerations for using injection moulding process. High production rates based on sizes, continuous lengths up to 60 m/min for some tubes sections and profiles, up to 5m/min for sheet and rod sections. Steeply increasing extruder costs at higher range of output. For high production rates, there can include several holds in die even though lead times are dependent on the die complexity. The tooling costs are not as high as injection moulding method, but equipment costs are still high. And finishing and direct labour costs are low.

### **3.3.4 Modelling of the Extrusion**

The designing of extrusion dies for production of complex geometries needs a wide knowledge. Moreover the extrusion die is the most essential part in the processing of extrusion and die design can provide very difficult process to execute, and/or the cost of die design is likely to be prohibitive, when complex geometry thermoplastic profiles are developed (Rauwendaal, 2014).

### **3.3.5 Considerations of die design of extrusion**

#### **3.3.5.1 Thickness**

Minimize wall thickness variations throughout the profile in order to reduce warpage, sinking, and residual stresses. According to the mechanical performances of the chosen material processed with the selected method, least thickness must be computed to satisfy regulations and specifications by safety margins. High thickness can result sinking, warpage and shrinkage, porosity and voids and need longer cooling time. Wall thickness can be reduced by designing ribs (Wilczyński, Nastaj, Lewandowski, Wilczyński, & Buziak, 2019).

#### **3.3.5.2 Flow velocity**

The difference in thickness provides large velocity differences. The average flow velocity can be calculated by dividing the volumetric flow rate by the cross-sectional area of the channel (Rauwendaal, 2014). The thickness differences of 50% the velocity difference can increase between 5:1 and 10:1, will cause resulting severe distortion in the final material part.

There is two ways to adjust die flow channel to make sure the average flow velocity is uniform, which are length of the channel and the height of the channel.

### **3.3.5.3 Ribs and partitions**

They can be used in the machine direction in order to increase rigidity. The shrinkage when cooling can be found as a longitudinal shrink marks on the opposite surface.

### **3.3.5.4 Tolerances**

Depending on the thicknesses, there can be distinguished into three tolerance classes; (1) easily controlled tolerances (For example, 0.3-0.85mm), (2) Difficult to control (For example, 0.45-1.2mm), (3) Very difficult to control (For example, 0.6-2mm)

## **3.4 Compression Moulding**

Compression moulding is typically used for thermoplastics which are difficult to process, such as fibre filled systems or thermoplastic elastomers. It is mainly used for thermosets but for the cast of thermoplastics which do not flow or do not melt due to highly filled systems and granular materials. Generally, the process involves very little flow but fuse under pressure. So, this process is suitable for the case of thermoplastic composite systems reinforced with long fibres.

Some of typical applications of compression moulding are dishes, housings, automotive parts, panels, handles, container caps, electrical components and fitting.

### **3.4.1 Design Aspects**

As compression moulding is selected for one of common manufacturing methods for difficult processing product, there are some design aspects which can be part of the considerations in the selecting appropriate processing method. Complex shape is recommended with relatively simple forms. Threads, ribs, inserts, lettering, holes and bosses are all possible. Moulding materials with reinforcing agents enable high strength directionality. Thin-walled parts with minimum warping and dimensional deviation is desired for moulding. Placing of parting line are important due to avoid placement across critical dimensions. Maximum section is 13mm meanwhile maximum area is 1.5m<sup>2</sup>. Minimum section is 0.8mm meanwhile minimum area is 3mm<sup>2</sup>. Typical maximum dimension is 450mm. Draft angle is required to be greater than 1°. Size range from several grams to 16 kg in weight.

### **3.4.2 Quality Issues**

There are also quality issues using compression moulding method. The weight variation in raw material charge results in variation of part thickness and scrap. Trapped air is possible. Internal stresses are minimal. In the direction of mould opening, dimensions and density of product can vary more than those perpendicular to the mould opening. Depending on various materials used, the achievable dimensional tolerances can be different and allowances should be added across the parting line, approximately  $\pm 0.1$ mm at least.

### **3.4.3 Economic Consideration**

There are always considerations for manufacturing method whether or not it is suitable for economic production. Depending on size and compounds, the production rates can be between 20 to 120hr. The thicker part design can give longer curing time. Mould maintenance is minimal. If die complexity is high, lead times can be several weeks. High material utilization

is occurred in this method. No sprues and runners are needed. Difference in shrinkage properties provides low flexibility of changes in material usage. Tooling costs are moderate to high and equipment costs are moderate. Direct labour costs are low to moderate and finishing costs are normally low. But flash removal is needed.

### 3.5 Conclusion of manufacturing process

According to the geometry of the compressor housing, the manufacturing process will be selected based on the design of the products. The following table shows that there are different processing methods for the various types of product geometry.

*Table 5-Processing Methods for the production of various types of geometry (Bonten, 2019)*

	Large-Area products	Housing-like products	Container-like products	Complex products without undercuts	Complex products with undercuts	Complex, thick-walled products	Complex products with internal contours
Pipe and profile extrusion				+			++
Sheet and film extrusion	++						
Extrusion blow moulding			++				
Thermoforming	++	+	+				
Conventional injection moulding		++	+	++		+	+
Injection moulding with sliders		++	+		++	+	++
Injection compression moulding	++					+	
Cascade injection moulding	++	+		++			
Assembly and composite injection moulding		++		++	+	++	
Fluid injection technology						++	++

Table 5 (Continued)

Injection stretch blow moulding			++				
Pressing	++						

In the case of plastic compressor housing, the process will be chosen based on the geometry such as housing like products and complex design. Among all of the manufacturing processes, conventional injection, injection moulding with sliders, cascade injection moulding and assembly and composite injection moulding are suitable for the proposed complex structural housings. Between all of the injection moulding methods, assembly and composite injection is the most appropriate manufacturing process according to two or more parts of housing components.

## Chapter 4

### Material Selection

---

#### 4.1 Literature Review

Polymeric materials have played an essential role in the development of this modern technology. These polymeric materials not only have an excessive versatility of properties but also provides several cost advantages. The structure of different polymeric materials is based on combination of different chemical elements such as carbon, oxygen, hydrogen, nitrogen, chlorine, and sulphur (Campo, 2006b). Therefore, it is possible to create different type of polymers with various property desired for the product.

Owing to various type of properties based on chemical structure, there are some plastic material which can melt at 200 °F, while other plastic materials can withstand high temperature above 1,000 °F. For example, there are some flexible plastic which is used in grocery products and there are rigid plastics which is used as support beams in construction. There are also polymers which have impact resistant and transparent properties used as windshields for airplanes, automobiles, and shower doors while there are also transparent packaging plastic materials which is used in protecting consumer items.

Modelling of high temperature heat transfer in polymeric materials has helped in the understanding of how polymers react to extreme environments (Institute of, 1992). With the understanding between polymer structures, physical and mechanical properties of polymeric materials, advances made in processing high temperature resistant polymers have showed the improvements in the performance in critical applications.

This chapter will discuss about very common high temperature thermoplastics and some of materials selection methods which need to be taken in developing a high temperature resistant polymer compressor housing.

#### 4.2 High performance polymers

High performance polymers are stated in various ways based on the applications and, on the organization developing or using material. Paul M. Hergenrother from NASA Langley Research Centre specifically defined high performance polymer as polymer which has unusual stability upon exposure to different type of harsh environment.(Hergenrother, 2003)

The most useful explanations of high performance are:

- a) Long-term durability (>10,000 h) at long term operation between the temperature of 150 and 177 degrees.
- b) Thermal decomposition temperature > 450°C, which is the temperature of 5% weight loss as measured by dynamic thermogravimetric analysis at a heating rate of 2.5 degree Celsius per minute
- c) Low weight loss rates at high temperature
- d) High heat deflection temperatures >177 ° C, which is temperature where 10% deflection can occur on a polymer specimen under a load of 1.52 MPa
- e) High aromatic content and relatively rigid segments that impart high glass transition temperature > 200 ° C and high mechanical properties

High temperature thermoplastics are utilized in special applications which need a combination of extraordinary properties. Based on their different application, there are short

term or long-term thermal stability, dimensional stability, flammability and other special mechanical properties which are considered as equal as metals. Even by using special reinforcing agents such as glass fibre, additives and graphite particles, the base polymer can further be improved to use in harsh environment (SpecialCham, 2020).

#### 4.2.1 Factors contributing to high performance and high temperature

Most of the factors provide high temperature resistance and performance in polymeric materials according to the polymeric structural analysis such as primary bond strength, resonance stabilization, secondary bonding forces, molecular weight and distribution, molecular symmetry (regularity of structure, crystallinity), rigid intrachain structure, crosslinking, purity, mechanism of bond cleavage and additives or reinforcement. In this paper, the detailed of polymer chemistry is not needed to discuss as the project will focus on the manufacturing processes.

#### 4.2.2 Comparative study between High Temperature Thermoplastics and Metals

In this section, the advantages and disadvantages of high-performance polymers over metals will be discussed. Because of light weight properties of polymers, high temperature thermoplastics which has continuous operating temperatures above 150 ° C are often considered for metal replacements in automotive applications (Ashby, 2010). However, there are also some disadvantages of plastics that cannot be competed with metal in some applications. Therefore, the pros and cons of high-performance polymers over metals will be summarized in the table below.

*Table 6-Pros and Cons of polymers over metals*

Advantages over Metals	Disadvantages over metals
<ul style="list-style-type: none"> <li>▪ High electrical and thermal insulation</li> <li>▪ Low density</li> <li>▪ Great noise and vibration damping</li> <li>▪ High adjustable conductivity</li> <li>▪ Moderate chemical and corrosion resistance</li> <li>▪ High design freedom</li> <li>▪ Adaptability to high volume production processes</li> <li>▪ Adaptability to modification of properties for specific applications</li> </ul>	<ul style="list-style-type: none"> <li>▪ Lower thermal resistance</li> <li>▪ Greater thermal expansion</li> <li>▪ Low creep resistance</li> <li>▪ Lower mechanical properties</li> <li>▪ Redesigned the part will be needed</li> <li>▪ Not considered to be a vapour barrier</li> <li>▪ Susceptible to UV, moisture and oxidation</li> <li>▪ Hard processing conditions</li> </ul>

### 4.2.3 Classification of high temperature thermoplastic

There are a variety of thermoplastics available for use as matrix resins in advanced composites and they have been described in the application of turbine engines, hot aircraft structures, and high speed aircraft structures (Rogers, 1995).

Among the engineering plastics category, high performance polymers have shown some exceptional properties compared to the majority to other plastic materials. Owing to their special properties, most of these thermoplastic are normally used as the base resins by combing with long glass and carbon fibres or high aspect filler (Mastro, 2016).

Based on their resin performance, the following thermoplastic are categorized into four groups as in the figure below (Ibeh, 2011):

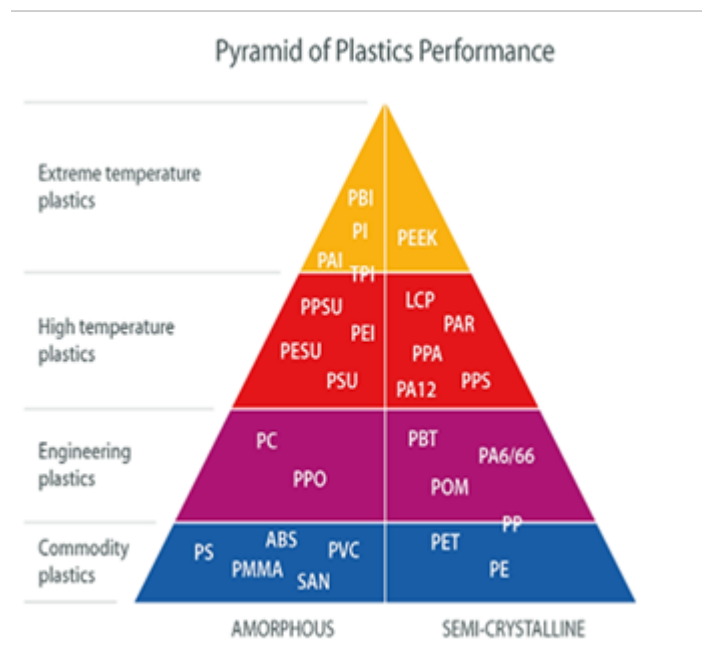

Figure 5: Pyramid of Plastics Performance (SpecialCham, 2020)

1. Commodity Thermoplastic
  - Acrylonitrile-butadiene-styrene (ABS)
  - Polymethylmethacrylate (PMMA)
  - Polyethylene terephthalate (PET)
  - K-resin
  - Styrene-acrylonitrile (SAN)
2. Engineering Thermoplastic Materials
  - Nylon
  - Polyacetal (PA)
  - Polycarbonate (PC)
  - Polyphenylene sulphide (PPS)
  - Cellulosic (acetate, butyrate, propionate)
  - Liquid crystalline polymers (LCPs)

3. Specialty Thermoplastic Materials
  - Polysulfone (PS)
  - Polytetrafluoroethylene (PTFE)
  - Polyphenylene oxide (PPO)
  - Polyimides (PI)
  - Polyetheretherketone (PEEK)
  - Liquid crystalline polymers (LCPs)
4. Extreme temperature Thermoplastic Materials
  - Functionalized Thermoplastics (FTPs)
  - Thermoplastic nanocomposites (TPNCs)
  - Polybenzimidazole (PBI)

For practical purpose, high performance polymers have either amorphous or semi-crystalline structure, which shows both amorphous and crystalline regions. There are two types of molecular structures: amorphous (Randomly ordered) and crystalline (Highly ordered) Both amorphous and crystalline polymers have been used in the various areas such as automotive, aerospace, medical and electronic industries where these properties are required.

*Table 7-Comparative properties between amorphous and crystalline thermoplastics*

Characteristics	Amorphous	Crystalline
1. Tensile strength	Lower	Higher
2. Tensile modulus	Lower	Higher
3. Ductility	Lower	Higher
4. Toughness	Lower	Higher
5. Isotropy	Isotropic	Anisotropic
6. Creep resistance	Higher	Lower
7. Maximum use temperature	Lower	Higher
8. Wear resistance	Lower	Higher
9. Mould shrinkage	Lower	Higher
10. Distortion	Lower	Higher
11. Specific gravity	Lower	Higher
12. Melting characteristics	Gradual flow above T <sub>g</sub>	Sharp melt transition at T <sub>m</sub>
13. Opacity	Transparent	Opaque
14. Chemical resistance	Lower	Higher

Among above listed high temperature resistant polymers, polymers which semi-crystalline structures have highly ordered molecular structure with high melting points and perform extremely well in applications including wear, bearings, and structural loads. As the comparative properties are listed in the above table, crystalline structure polymers provide very good stiffness and strength, higher toughness than amorphous polymers. Moreover, crystalline polymers also provide higher chemical resistance than amorphous polymers.

However, there are some negative points of crystalline polymers such as higher mould shrinkage and lower impact resistance compared to amorphous materials. It means that

crystalline polymers shrink more in the direction transverse to flow than along the direction of flow. Therefore, crystalline polymers result in dimensional instability rather than amorphous polymers.

From that point, some of the crystalline and semi-crystalline polymers such as PEEK, PPS, and PBT are initially selected for the high temperature applications according to the temperature requirement in the compressor housing design.

#### **4.2.4 Fibre Reinforcement**

Fibre reinforcement has been used for a long time in order to improve some mechanical and thermal properties of thermoplastic and thermoset materials, under various forms: short, long, or continuous fibres of glass, carbon, textile, natural fibres, and so on. Fibre reinforced composite materials involves polymer matrix with some typical reinforcements for plastic materials such as carbon fibres, glass fibres, and aramid fibres. Increasing number of high performance components utilize reinforced materials due to their superior characteristics such as high strength and stiffness, low weight and high fatigue resistance (Sathishkumar, Satheeshkumar, & Naveen, 2014).

For the purpose of better Tensile strength and tensile modulus, short glass fibres (GFs) are the most used fibres. Long glass fibre reinforced thermoplastic is used for demanding applications in automotive. Moreover, well ordered continuous fibres called UD composites or filaments winding are used for the purpose of highest performances. Despite Carbon fibre reinforced composites provide high performances, they have highest costs, which can lead to limitations of usage to metal replacement solutions concerning.

The process of reinforcement depends on the fibre level, the aspect ratio, the chemical linking and the wetting by the matrix. Typical fibre diameters range between 0.002 and 0.02 (0.0001 to 0.001 in), and the tensile strength of glass fibres vary between 3,000 and 5,000 MPa (435,000 to 725,000 psi). Young's modulus ranges from 70,000 to 90,000 MPa and ultimate strain range between 4 and 5%. Among available different forms of reinforcements, chopped fibres are most common used to reinforce a variety of resins used in the process such as injection moulding and compression moulding.

### **4.3 Selection of high-performance thermoplastic**

Each of high temperature thermoplastic resins has its own advantages and disadvantages relative to their processing characteristics and performance properties. The limitations, popular applications and processing conditions of selected high temperature thermoplastic resins will be analysed in details in this chapter. According to design requirement of final product, some of relevant thermoplastic resins have been selected based on high temperature resistance, up to 200 °C.

#### **4.3.1 Polyetheretherketone (PEEK)**

Polyetheretherketone is a semi-crystalline high performance engineering thermoplastic which has a combination of high mechanical strength, chemical resistance, wear, fatigue, creep resistance as well as high temperature resistance above 260° C (Ibeh, 2011).

Most of studies have showed PEEK as the most extensively used member among polymer classes (Garcia-Leiner, Reitman, El-Hibri, & Roeder, 2017). PEEK has both Tg and Tm at 145° C and 335 ° C, respectively. It can also withstand temperatures of 240-280 ° C for continuous use. PEEK can also be completely recyclable.

#### 4.3.1.1 Properties of PEEK

Owing to a great combination of specific strength, stiffness, low weight and high mechanical properties, PEEK shows the ability of surviving longer in harsh environments. There are specific properties of PEEK. First of all, its excellent tensile properties, which strength of 29,000 psi at temperature 299 degree by reinforcing with carbon fibres. Secondly, PEEK also has excellent wear, creep, and chemical resistance and fatigue performance. Moreover, it has high volume resistivity as well as surface resistivity. Great insulating is one of the useful properties in a wide range of temperature and environmental changes. High dimensional stability, high thermal stability and flammability resistance are benefits of PEEK materials. Last but not least, ease of processing and long life are the most beneficial parts of PEEK properties.

#### 4.3.1.2 Well-known properties of PEEK

In order to summarize all of the data, here are listed necessary properties for FEA analysis, which may be next step of this project.

*Table 8-Well-known properties of PEEK (SpecialCham, 2020) (data from various resources)*

<b>Polyetheretherketone (PEEK)</b>	
Properties	Unfilled
Density	1.33g/cc
Filler Content	0
Water Absorption	0.182%
Moisture Absorption	0.264%
Viscosity	183000cP
Linear Mould Shrinkage	0.0107cm/cm
Melt Flow	30.2g/10 min
Spiral Flow	150cm
Hardness, Rockwell	102
Tensile Strength, Ultimate	99.1MPa
Tensile Strength, Yield	97.7MPa
Elongation at Break	24.70%
Elongation at Yield	7.19%
Modulus of Elasticity(Young's)	3.90GPa
Flexural Yield Strength	155MPa
Flexural Modulus	4.23GPa
Flexural Strain at Break	5.22%

Table 8 (Continued)

Compressive Yield Strength	116MPa
Poisson's ratio	0.39-0.41
Bulk Modulus	5.48-5.75GPa
Fatigue Strength	28.1-41.2MPa
Shear Strength	75.2MPa
Izod Impact, Notched	5.62kJ/m <sup>2</sup>
Coefficient of Friction	0.271
K(wear) Factor	467x10 <sup>-8</sup> mm <sup>3</sup>
Electrical Resistivity	2.23e+16ohm-cm
Surface Resistance	1.77e+17ohm
Dielectric Constant	3.21
Dielectric Strength	38.7kV/mm
Melting Temperature	342°C
Glass Transition Temperature	146°C
Maximum Service Temperature	261°C
Minimum Service Temperature	(- 50.3°C)
Specific Heat Capacity	1.57J/g-°C
Coefficient of Thermal Expansion(CTE)	108µm/m-°C
Thermal Conductivity	0.293W/m-K
Deflection Temperature at 1.8 MPa	163°C
Flammability	self-extinguished
Processing Temperature	262°C
Nozzle Temperature	373°C
Melt Temperature	373°C
Mould Temperature	185°C
Drying Temperature	139°C

Due to reinforcement with glass or carbon fibres, PEEK can also provide an excellent balance of properties where the desired product is required to withstand high repetitive loadings over time to time periods at very high temperature without permanent deformations. Here are some comparative summarized properties between unfilled PEEK and reinforced PEEK.

Table 9-Summary of reinforced properties of PEEK (SpecialCham, 2020)

(PEEK)	Unfilled	Carbon Reinforced	Glass Reinforced
Filler content (%)	0	28.80%	30
Density(g/cc]	1.33	1.44	1.53
Tensile Strength( MPa)	99.1	258	162
Elongation at Break (%)	24.7	1.89	2.97
Flexural Modulus (GPa)	4.23	21.4	10.4
Izod notched Impact Strength (J/cm)	0.613	0.681	0.915
HDT/A (1.8 MPa)(°C)	163	296	289
Melting Point(°C)	342	342	343
Maximum Service Temperature (°C)	261	261	259

#### 4.3.1.3 Limitations of PEEK

Even though PEEK has an excellent combination of properties, there is a number of limitations. First of all, it can only be used for highly demanding application because of its expensive cost. Secondly, processing can be limited because of its high melting temperatures. PEEK can most likely be attacked by sulphuric, nitric acid and halogens and sodium. It has low resistance from UV light.

#### 4.3.1.4 Popular applications

**Automotive application-**Owing to an outstanding mechanical performance over a wide range of temperature, ease of processing compared to other thermoplastic resins, light weight and fatigue properties, PEEK has been chosen to replace metals in automotive applications. The most famous applications of PEEK in automotive are as bearings, piston parts, wire coating, seals, washers, braking and air-conditioning systems and various active components used in transmission

**Aviation and aerospace application-** PEEK has become a material choice in several areas of application in aviation and aerospace such as interior components, technical parts, structural elements and components for navigation propulsion engineering and satellite technology.

**Electrical and electronic application-** PEEK makes as an ideal electrical insulator because PEEK has an excellent insulating properties and long-term operating reliability over widely fluctuating ranges of temperature, pressure and frequency. For example, coaxial connector jacks used in hands-free telephone kits, surface-mounted trimming potentiometers, which are electro-mechanical devices known as SMDs, designed to correct voltage or resistance errors in

printed circuit boards, and as in insulators for connector ins on under-sea environment control equipment.

### 4.3.2 Polyphenylene Sulphide (PPS)

Polyphenylene Sulphide is a semi-crystalline material and exhibits an excellent balance of properties, including high temperature resistance, chemical resistance, flowability, dimensional stability and electrical characteristic. PPS has a rigid and opaque structure with a high melting point of 280 ° C. PPS polymer is made up of para-phenylene units alternating with sulphide linkages (Fink, 2008).

PPS shows its glass transition temperature Tg of 85-90° C. and melting temperature around 280-295 ° C. Owing to low melt viscosity characteristics, PPS resins can be moulded with high loadings of fillers or reinforcing materials and enhance its mechanical and thermal properties.

#### 4.3.2.1 Properties of PPS

PPS has low degradation characteristics even in high temperature conditions. Having brittle and notch sensitive behaviours, PPS needs to be added a rubber modifier to obtain a significant improvement in the notched Izod impact toughness.

As PPS is a high-temperature specialty polymer, PPS has a great thermal resistance to 260°C for short time and used below 200°C for a long time. Owing to high dimensional stability, PPS is an ideal material of choice to produce complex parts with very tight tolerances.

PPS has excellent electrical insulation properties, and the volume resistivity and the dielectric strength remain high up to 200 °C. PPS has good chemical resistance, however, a lower elongation to break, lower stability to UV light, higher cost and is rather brittle.

#### 4.3.2.2 Well-known properties of PPS

In order to summarize all of the data, here are listed necessary properties for FEA analysis, which may be next step of this project.

*Table 10-Well-known properties of PPS (SpecialCham, 2020) (data from various resources)*

<b>Polyphenylene Sulphide (PPS)</b>	
Properties	Unfilled
Density	1.33g/cc
Filler Content	0
Water Absorption	0.0617%
Moisture Absorption	
Viscosity	
Linear Mould Shrinkage	0.6-1.4%
Melt Flow	17.0g/10min
Spiral Flow	

Table 10 (Continued)

Hardness, Rockwell	89.7
Tensile Strength, Ultimate	114MPa
Tensile Strength, Yield	64-67.2MPa
Elongation at Break	21.20%
Elongation at Yield	10.00%
Modulus of Elasticity	3.12GPa
Flexural Yield Strength	109MPa
Flexural Modulus	3.32GPa
Flexural Strain at Break	
Young's Modulus	3.23-3.39GPa
Poisson's ratio	0.382-0.398
Bulk Modulus	4.89-5.14GPa
Compressive Yield Strength	105-116MPa
Fatigue Strength	19.3-34.5MPa
Shear Strength	19.9kJ/m <sup>2</sup>
Izod Impact, Notched	1.3-2.6kJ/m <sup>2</sup>
Coefficient of Friction	
K(wear) Factor	
Electrical Resistivity	9.68e+15ohm-cm
Surface Resistance	4.20e+15ohm
Dielectric Constant	3.17
Dielectric Strength	22.6kV/mm
Melting Temperature	280°C
Glass Transition Temperature	89.5°C
Maximum Service Temperature	226°C
Minimum Service Temperature	(-20°C)
Specific Heat Capacity	
Coefficient of Thermal Expansion(CTE)	62.8 µm/m-°C
Thermal Conductivity	0.256 W/m-K
Deflection Temperature at 1.8 MPa	131 °C
Flammability	Self-Extinguishing
Processing Temperature	300-350°C
Nozzle Temperature	
Melt Temperature	309°C
Mould Temperature	135-155°C
Drying Temperature(5hr)	120°C

In the market of high-performance polymers, PPS is more applicable when filled with glass fibre, carbon fibre and PTFE. The resin is reinforced with different reinforcing materials or blended with other thermoplastics to develop its significant properties. Here are some comparative summarized properties between regular PPS and reinforced PPS.

*Table 11-Summery properties of Reinforced PPS(SpecialCham, 2020)*

(PPS)	Unfilled	Carbon Reinforced	Glass Reinforced
Filler content (%)	0	31.30%	29.8
Density(g/cc)	1.33	1.48	1.56
Tensile Strength( MPa)	114	168	146
Elongation at Break (%)	21.2	1.23	1.77
Flexural Modulus (GPa)	3.32	21	11.3
Izod notched Impact Strength (J/cm)	1.03	0.617	0.908
HDT/A (1.8 Mpa)(°C)	131	264	257
Melting Point(°C)	280	279	277
Electrical Resistivity (ohm-cm)	9.68E+15	2000	3.90E+16

#### **4.3.2.3 Popular Applications**

**Automotive application-** Because of lighter weight and high corrosion resistance to salts and all automotive fluids, PPS has been used as an alternative of metals and thermosets. Some popular applications in automotive are fuel injection, coolant system, water pump impellers, thermostat holder, electric brakes, switches, bulb housing and so on.

**Electronic and electrical applications-**Due to having high temperature resistance, low density, corrosion and hydrolysis resistance, high toughness, good dimensional stability and good rigidity, PPS has been a great choice for electronic appliances such as heating and air conditioning components, fry pan handles, hair dryer grills, steam iron valves, toaster and dryer switches, microwave oven turntables, and so on.

#### **4.3.3 Polyimide (PI)**

One of the new class of specialty polymeric materials is polyimide (PI). PI is an amorphous thermoplastic resin with amber transparency. PI has an excellent combination of mechanical properties, therefore it is used to replace the conventional use of glass, metals and even steel in various industrial applications (Xiantao Feng, 2008).

PI exists in both formats such as thermosetting and thermoplastic and can also be categorized as aliphatic, aromatics, semi-aromatics thermoplastics and thermosets.

#### 4.3.3.1 Properties of Polyimide

Polyimide has a unique combination of high specific strength, rigidity, flexibility, exceptional dimensional strength etc. Polyimide resin can be used in an unreinforced grade for general purpose processing method (McKeen, 2019). However, after reinforced with glass fibre, it can also be improved to greater rigidity and dimensional stability meanwhile keeping up with original useful characteristics of basic PI. Glass reinforced PI yields a product with an excellent strength-to-weight ratio and increased tensile strength.

The overall properties of polyimide are; (a) Excellent tensile and compressive properties, (b) excellent electrical insulation, (c) outstanding chemical resistance, (d) good hydrolytic stability, (e) superior dimensional stability, (f) high viscosity, (g) good creep resistance and (h) good UV light resistance.

#### 4.3.3.2 Well-known properties of PI

In order to summarize all of the data, here are listed necessary properties for FEA analysis, which may be next step of this project.

*Table 12-Well-known properties of PI (SpecialCham, 2020) (data from various resources)*

<b>Polyimide (PI)</b>	
Properties	
Density	1.31g/cc
Filler Content	0
Water Absorption	0.41%
Moisture Absorption	0.70%
Viscosity	
Linear Mould Shrinkage	0.00940cm/cm
Melt Flow	9.36g/10min
Spiral Flow	
Hardness, Rockwell	91-100
Tensile Strength, Ultimate	81.6MPa
Tensile Strength, Yield	57.9MPa
Elongation at Break	19.00%
Elongation at Yield	90.00%
Modulus of Elasticity	3.73GPa
Flexural Yield Strength	98.9MPa
Flexural Modulus	2.82GPa
Flexural Strain at Break	
Poisson's ratio	0.391-0.407
Bulk Modulus	3.84-4.03GPa
Compressive Yield Strength	77.2MPa
Fatigue Strength	21.4MPa
Shear Strength	78.5MPa

Table 12 (Continued)

Izod Impact, Notched	0.848J/cm
Coefficient of Friction	
K(wear) Factor	
Electrical Resistivity	3.85e+17ohm-cm
Surface Resistance	3.68e+17ohm
Dielectric Constant	3.34
Dielectric Strength	16.3-22kV/mm
Melting Temperature	375-401°C
Glass Transition Temperature	250°C
Maximum Service Temperature	221-241°C
Minimum Service Temperature	(-248-((-238)))°C
Specific Heat Capacity	1.04J/g-°C
Coefficient of Thermal Expansion (CTE)	51.3µm/m-°C
Thermal Conductivity	0.246W/m-K
Deflection Temperature at 1.8 Mpa	200°C
Flammability	Self-Extinguishing
Processing Temperature	380-430°C
Nozzle Temperature	
Melt Temperature	390-393°C
Mould Temperature	170-210°C
Drying Temperature(5h)	200°C

In spite of the fact that polyimide has a group of very useful properties among high performance polymers, there are also certain limitations such as high manufacturing cost, high processing temperature requirement and sensitive to alkali and acid attacks

Table 13-Summary of reinforced properties of PI (SpecialCham, 2020)

(PI)	Unfilled	Carbon Reinforced	Graphite Reinforced
Filler content (%)	0	26.7	21.7
Density(g/cc]	1.31	1.48	1.48
Tensile Strength( Mpa)	81.6	158	59.9
Elongation at Break (%)	19	2.17	3.33
Flexural Modulus (GPa)	2.82	14.3	4.02

Table 13 (Continued)

Izod notched Impact Strength (J/cm)	0.848	0.921	0.298
HDT/A (1.8 Mpa)(°C)	-	316	347
Glass Transition Temperature(°C)	250	350	347
Maximum Service Temperature (°C)	-		298

#### 4.3.3.3 Popular applications

Due to its exceptional mechanical strength, electrically insulating properties and thermal stability, polyimide is widely used in electronic applications in aerospace and automotive industries (Liaw et al., 2012).

These popular electronic appliances include electroluminescent devices, polyelectrolytes, fuel cells, electrochromic materials, nanomaterials, polymer memory materials, liquid crystal alignments, test holders, chip trays, hard disk drive components, electrical connector, coil bobbins, wire insulators and digital copier and printer components etc.

Polyimide films are widely used for insulating circuit boards, high-temperature powder coating, and di-electric substrate in flexible solar cells where the desirable properties of high physical, electrical, mechanical properties and good dimensional stability over a wide temperature range are required.

Processing conditions

#### 4.3.4 Acrylonitrile-butadiene-styrene (ABS)

ABS is an amorphous polymer which has good impact resistant properties. ABS is combined with three monomers: acrylonitrile, butadiene and styrene. ABS has relatively low melting temperature compared with other high-performance polymers.

##### 4.3.4.1 Properties of Acrylonitrile-butadiene-styrene

ABS is an excellent material choice for structural applications because of its high rigidity properties. It also has good insulating properties, weldability, abrasion and strain resistance and impact resistance, even at low temperatures. Moreover, it shows high dimensional stability, which means mechanically strong and stable over time to time, surface brightness and excellent surface aspect.

Although ABS have poor resistance to aromatic hydrocarbons, halogenated hydrocarbons and alcohols, it has very great resistance to diluted acid and alkalis. It also has average resistance to aliphatic hydrocarbons.

Several physical and chemical properties will be summarized as follow. ABS have high rigidity and dimensional stability. It also has good impact resistance even at low temperature.

#### 4.3.4.2 Well-known properties of ABS

In order to summarize all of the data, here are listed necessary properties for FEA analysis, which may be next step of this project.

Table 14-Well-known properties of ABS (SpecialCham, 2020) (data from various resources)

<b>Acrylonitrile Butadiene Styrene(ABS)</b>	
Properties	
Density	1.18g/cc
Filler Content	0
Water Absorption	0.27%
Moisture Absorption	
Viscosity	159000cP
Linear Mould Shrinkage	0.00505cm/cm
Melt Flow	17.3g/10min
Spiral Flow	
Hardness, Rockwell	101
Tensile Strength, Ultimate	37.1MPa
Tensile Strength, Yield	40.5MPa
Elongation at Break	14.10%
Elongation at Yield	4.59%
Modulus of Elasticity	2.20GPa
Flexural Yield Strength	63.8MPa
Flexural Modulus	2.32GPa
Flexural Strain at Break	
Poisson's ratio(5mm/min)	0.4155
Bulk Modulus	
Compressive Yield Strength	
Fatigue Strength	
Shear Strength	
Izod Impact, Notched	17.0kJ/m <sup>2</sup>
Coefficient of Friction	
K(wear) Factor	
Electrical Resistivity	1.48e+15ohm
Surface Resistance	3.66e+14ohm
Dielectric Constant	2.99
Dielectric Strength	27.5kV/mm
Melting Temperature	
Glass Transition Temperature	

Table 14 (Continued)

Maximum Service Temperature	62.8°C
Minimum Service Temperature	
Specific Heat Capacity	
Coefficient of Thermal Expansion(CTE)	93.4µm/m-°C
Thermal Conductivity	
Deflection Temperature at 1.8 Mpa	86.6°C
Flammability	
Processing Temperature	220°C
Nozzle Temperature	208°C
Melt Temperature	204°C
Mould Temperature	61.4°C
Drying Temperature	81.7°C

Meanwhile ABS is useful for many applications in several fields, apart from its advantages, it also has limitations. They are poor weathering resistance, low continuous service temperature, poor solvent resistance, easy scratches, and low dielectric strength and can suffer from stress cracking in the presence of greases.

Table 15-Summary of reinforced properties of ABS (SpecialCham, 2020)

(ABS)	Unfilled	Carbon Reinforced	Glass Reinforced
Filler content (%)	0	30	29.3
Density(g/cc)]	1.18	1.2	1.28
Tensile Strength( Mpa)	37.1	115	80.7
Elongation at Break (%)	14.1	1.38	2.49
Flexural Modulus (GPa)	2.32	14.6	7.17
Izod notched Impact Strength (J/cm)	1.84	0.547	0.686
HDT/A (1.8 Mpa)(°C)	63.3	106	104
Electrical Resistivity(ohm-cm)	1.48E+15	179	6.46E+15

#### 4.3.4.3 Applications of ABS

Due to processing several properties such as high impact strength, high rigidity and high heat performance, ABS has been chosen in a great use in automotive applications and transportation, household appliances as well as electrical and electronics appliances.

Popular applications of ABS in various fields include pillar trim, dashboard components, door liners and handles, seat belt components, instrument panels, appliance panels, appliance control panels, computer keyboards keycaps and 3D printing. Due to corrosion resistance, ABS is also used in making pipes and fittings, sport equipment, gardening tools, medical applications, manufacturing nebulizers and compressors.

#### 4.3.5 Polybenzimidazole (PBI)

Polybenzimidazole (PBI) is an aromatic heterocyclic thermoplastic and known for high strength and extremely high temperature performance. Among high performance polymer family, PBI possesses the highest temperature resistance and mechanical properties with a glass transition temperature which is in the range 400-425 °C (Fink, 2008).

Due to lacks of the thermoplastic processability and relatively poor long-term thermooxidative stability, PBI is normally blended with other polymer resins and materials to be take advantage of the unique high performance properties for the desired end product which needs to be improved thermal, chemical, processability and mechanical targets (DeMeuse, 2014).

##### 4.3.5.1 Properties of Polybenzimidazole

PBI has remarkably high heat resistance with efficient mechanical properties, therefore it is suitable for the applications in hostile environments. Most ideal properties of PBI are listed below:

- Excellent thermal and chemical stability
- Excellent electrical insulating property
- Superior dimensional stability
- High tensile and compressive properties
- High wear resistance
- High load carrying capabilities at extreme temperatures
- Excellent flame resistance

##### 4.3.5.2 Well-known properties of PBI

In order to summarize all of the data, here are listed necessary properties for FEA analysis, which may be next step of this project.

*Table 16-Well-known properties of PBI (SpecialCham, 2020) (data from various resources)*

<b>Polybenzimidazole (PBI)</b>	
Properties	
Density	1.29-1.31
Filler Content	0
Water Absorption	0.40%
Moisture Absorption	
Viscosity	
Linear Mould Shrinkage	

Table 16 (Continued)

Melt Flow	
Spiral Flow	
Hardness, Rockwell	104
Tensile Strength, Ultimate	160
Tensile Strength, Yield	130-160MPa
Elongation at Break	3%
Elongation at Yield	3%
Modulus of Elasticity	5.90GPa
Flexural Yield Strength	
Flexural Modulus	6.50GPa
Flexural Strain at Break	215-226MPa
Poisson's ratio	0.368-0.369
Bulk Modulus	5.79-6.4GPa
Compressive Yield Strength	390MPa
Fatigue Strength	56.0MPa
Shear Strength	6.12-6.71MPa
Izod Impact, Notched	3-3.5kJ/m <sup>2</sup>
Coefficient of Friction	0.14
K(wear) Factor	
Electrical Resistivity	1e12-1e13μohm-cm
Surface Resistance	
Dielectric Constant	3.3
Dielectric Strength	23.0kV/mm
Melting Temperature	590-592°C
Glass Transition Temperature	427°C
Maximum Service Temperature	302-318°C
Minimum Service Temperature	(-51-(-48.8))°C
Specific Heat Capacity	1.27e3-1.41e3J/kg°C
Coefficient of Thermal Expansion (CTE)	23μm/m-°C
Thermal Conductivity	0.403W/m-K
Deflection Temperature at 1.8MPa	435°C
Flammability	Non-Flammable
Processing Temperature	
Nozzle Temperature	
Melt Temperature	547-589°C
Mould Temperature	
Drying Temperature	

#### 4.3.5.3 Applications

Polybenzimidazole is very useful for the production of high temperature stable moulded and extruded products such as films, fibres, coatings, moulded shapes, membrane, forms and composites. Owing to considerable mechanical and thermal insulating properties, those PBI films and foams provide as beneficial candidates for fabricating space suits.

Besides, due to the fact that PBI is a hydrophobic in nature and its powder or shaped articles cannot be wet with a hydrophilic solvent, other plastic in melt do not stick to PBI. Therefore, it is suitable for the application of contact seals and insulator bushings in production and moulding equipment of other types of plastic.

#### 4.4 Tools of selecting materials (Pugh Screening Method)

From the above the selected polymer materials, one of the selecting materials tools called Pugh Screening method will be used to filter the essential properties for the plastic compressor housing.

*Table 17-Comparative properties between selected materials and aluminium alloy*

Requirements	Baseline	ABS	PI	PEEK	PBI	PPS
Melting Point	677-816		375-401°C	373°C	590-592°C	309°C
Density	2.77g/cc	1.18g/cc	1.31g/cc	1.33g/cc	1.29-1.31	1.33g/cc
Processing Temperature	562 °C	220 °C	221-241°C	261°C	302-318°C	226°C
Specific Heat	0.963J/g-°C		1.04J/g-°C	1.57J/g-°C	1.27e3-1.41e3J/kg°C	1.33J/g-°C
Young's Modulus	71 GPa	2.20GPa	3.73GPa	3.90GPa		3.12GPa
Yield Strength	280MPa	40.5MPa	57.9MPa	97.7MPa	130-160MPa	64-67.2MPa
Tensile Strength	310MPa	37.1MPa	81.6MPa	99.1MPa	160	114MPa
Elongation	>=3.0%	14.10%	19.00%	24.70%	3%	21.20%
Fatigue Strength			21.4MPa	28.1-41.2MPa	56.0MPa	19.3-34.5MPa

Table 18 Selecting materials by Pugh Screening method

Requirements	Baseline(Aluminium Alloy)	ABS	PI	PEEK	PBI	PPS
Melting Point	677-816		+	+	+	+
Density	2.77g/cc		+	+		+
Processing Temperature	562 °C			+	+	+
Specific Heat	0.963J/g-°C			+		
Young's Modulus	71 GPa					
Yield Strength	280MPa			+	+	
Tensile Strength	310MPa				+	+
Elongation	>=3.0%					
Fatigue Strength	151 MPa			+		

According to the filtering the essential properties of selected materials, PPS and PEEK are seemed to be good options among five thermoplastic polymers. Especially, selecting materials are based on the temperature and strength. However, the properties of base polymer like PEEK and PPS themselves are not comparable with aluminium alloy. So, next stage of analysis will be carried out with reinforced polymers and aluminium alloy.

Table 19-Comparative properties between Reinforced polymers and Aluminium Alloy

	Baseline(Aluminium Alloy)	Carbon Reinforced PEEK	Carbon Reinforced PPS
Filler content (%)		28.80%	31.30%
Density(g/cc)]	2.77g/cc	1.44	1.48
Tensile Strength( Mpa)	310MPa	258	168
Elongation at Break (%)	>=3.0%	1.89	1.23
Melting Point(°C)	677-816	342	279
Maximum Service Temperature (°C)	562 °C	261	279

Table 20-Selecting materials by Pugh screening method

	Baseline(Aluminium Alloy)	Carbon Reinforced PEEK	Carbon Reinforced PPS
Filler content (%)			
Density(g/cc)	2.77g/cc		+
Tensile Strength( Mpa)	310MPa	+	
Elongation at Break (%)	>=3.0%		+
Melting Point(°C)	677-816	+	
Maximum Service Temperature (°C)	562 °C	+	+

#### 4.5 Conclusion of Selection materials

In comparison between reinforced polymers and alloy which has been used in compressor housing application, the results of properties are greater than base polymers. As the selecting materials are narrowed down to filter suitable and essential properties, the result has come out once Pugh screening method has used for two stages. The method filtered materials among base polymers as a first stage. Second stage is shown the comparison between reinforced polymers and alloy. The detail explanation will be followed in the final chapter with appropriate graphs and figures.

## Chapter 5

### Cost Analysis

---

#### 5.1 Literature Review

In the developing new product design, cost analysis is one of the main factor to be taken into consideration. When conducting cost analysis in the study, there are some key points which should be included in the comparative cost analysis(Campo, 2016).

Cost model can give an estimation the manufacturing cost of moulding components (Shehab & Abdalla, 2001). Most designers consider the design for cost effectiveness instead of performing the cost estimation after producing design parts (Irisarri, Macquart, Julien, & Espinassou, 2019). The characteristics of the product design development facilitate product cost analysis. Based on design for cost effectiveness, the cost model, which has the relationships between cost factors, product development activities and product geometry, must be proposed in the pre-design stage.

It is challenging for a designer of plastic components which is functionally acceptable, producible and cost effective at the design stage. The factors that affect the cost of a component includes material cost, tooling cost, manufacturing method, cost of tolerance and surface finishes for the selected manufacturing method(Chen & Liu, 1999). Most of the factors are also linked to the components geometric characteristics.

Generally, there are some considerations taken by the product designer, which is related to some relevant aspects such as the functional role of the part, the mechanical and thermal loads, and the part cost. Injection moulding is the most widely used in the fabrication of thermoplastic polymeric products, which gives high production rates, excellent quality and accuracy of products, and relevant manufacturing cost.

The part cost can be categorized by three main components: (1) the mould cost, (2) the equipment operation cost, and (3) the material cost. The injection moulded part cost can be expressed as the following formula (Turc, Cărauşu, & Belgiu, 2017):

$$K = \frac{K_d}{N} + K_e + K_m \quad \text{Equation 5}$$

The terms are referred to as:

$K_d$  – the mould cost

$N$  – the production volume

$K_e$  – the equipment operation cost

$K_m$  – the part material cost

#### 5.2 Moulding product cost analysis

*Mould Cost*-The main cost factor for a mould is its size and structure. The cost evaluation model of a mould can be developed by combining the cost structure and the moulding product design process. Other associated factors dealing with mould cost are the cost of mould base, the mould manufacturing costs, mould setup costs, which are related with the number of cavities, part size, and tolerances. The cost of mould depends on some factors including moulding material, part size, and the number of cavities(Turc et al., 2017).

The concerns of mould design include material filling, product functionality, mould quality as well as mould fabrication costs. General mould design can be determined by mould shrinkage,

cavity and core layout, parting line determination, feed system design, cooling system design, ejector design, and venting design.

*Processing Cost*- The operating cost per mould can be obtained by adding the machine rate per unit time and direct labour rate per unit time. The processing cycle time normally consists of solidification time, the machine operation time, which can be found in the database of machine. The processing design is depending on the geometric characteristics of the product and the mould design. Therefore, complicated geometric design part can affect the operation or manufacturing cost.

*Material cost*- Material cost can be calculated using the weight of the part multiplied by the cost of a unit weight of material including an allowance for material waste. The cost of allowance for material waste in moulding refers to tare costs, scrap costs and in-plant processing costs.

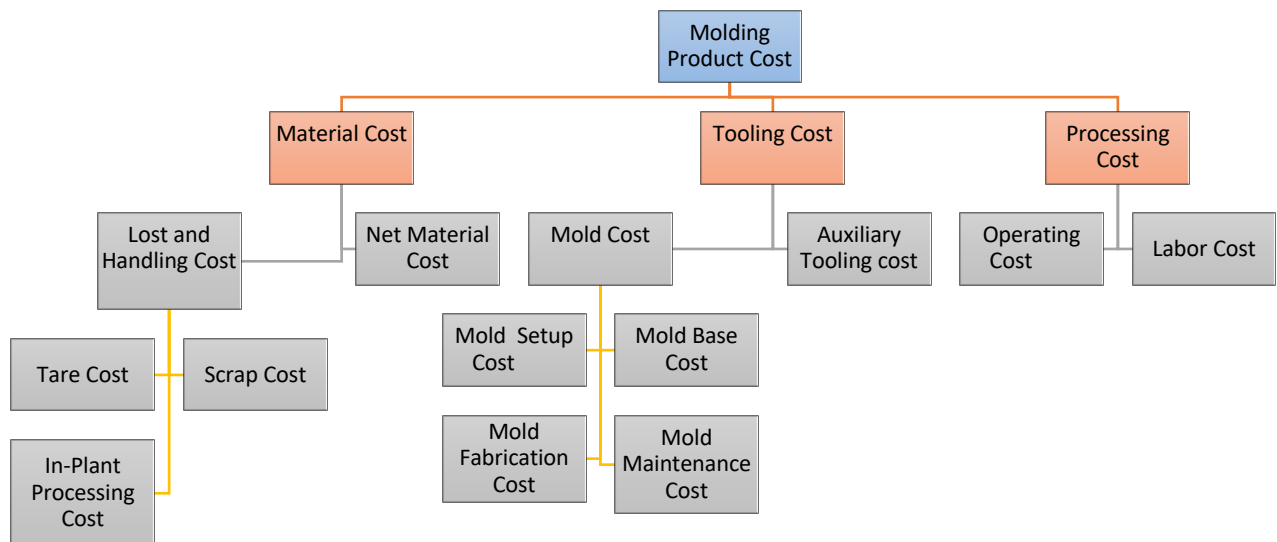

Figure 6: Design for moulding product cost (Asiedu & Gu, 1998)

### 5.3 Life cycle cost analysis

The life cycle cost analysis in the design of products has a massive potential to achieve a successful manufacturing process. A product designer should not only focus on a product description but also ensure the compatibility of the product design relating with its physical and functional requirements (Asiedu & Gu, 1998). Therefore, the life of product measured by its performance, effectiveness, producibility, reliability, maintainability, supportability, quality, recyclability, and cost, is important to consider in the design stage.

The reasons why life cycle cost is essential in the manufacturing processes are listed as follows(Dunk, 2001):

1. To have better the effectiveness of planning by comparing between actual budgeted life cycle costs and the distribution of those costs.
2. To increase the capacity to make better pricing analysis and decisions.
3. To enhance the assessment of product profitability.
4. To design more environmental friendly products.
5. To facilitate the environmental impact of products during manufacturing process and to understand potential recycling process.
6. To pay attention on factors which have a great percentage of life cycle costs, such as warranty, cost of parts, service and maintenance as well as customer's satisfaction on the pricing.

#### 5.4 Life Cycle Cost Modelling

Manufacturing and life cycle costs are obtained from a technical cost model modified for use and end of life costs, therefore resulting a more accurate basis for comparison than estimations. Basically, the determination of the cost model incurred within the overall life cycle is the sum of the several costs depending on the type and quantity of the used resources, materials and energy and their specific process costs (R.Folgado, 2010).

For application of cost model to the different processes, several data inputs, such as materials, part, machine tools, time, equipment, operator and part batch, are required. Therefore, the total cost is categorized by three types of costs;

1. The Process Costs ( including machine and labour costs)
2. The Materials Costs (raw materials consumptions and standard components, disposable tools)
3. The Energetic Costs(related with the amount of energy consumed by the equipment)

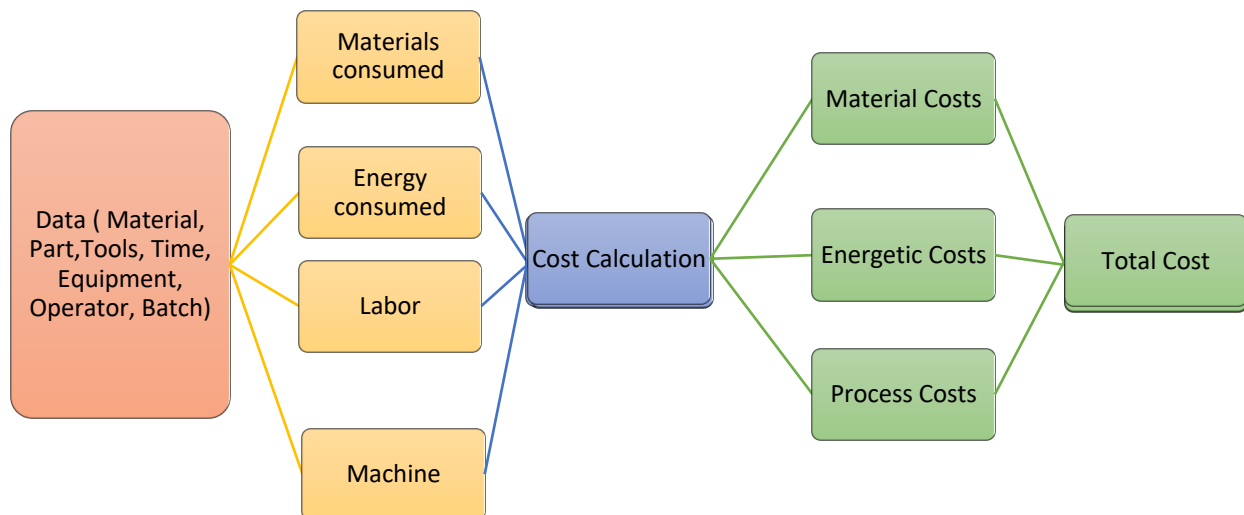

Figure 7: Life Cycle Cost Model (R.Folgado, 2010)

## **5.5 Material cost analysis**

The material selection process has generally been controlled by cost and determines the effects of materials and process change. As the designing of high performance component with lighter weight is aimed for the purpose of lower emissions, selecting materials on the basis of low cost is no longer appropriate (Witik, Payet, Michaud, Ludwig, & Månson, 2011). Therefore, the environmental performance of a material needs to be taken into consideration over the full life cycle of a product.

The life cycle cost related to light weight material has shown increases in materials and manufacturing costs. Despite the light weight material scenarios had weight reductions ranging between 62% and 69% compared to other heavy material component like steel, high performance materials have more of the materials and manufacturing. The relative success of light weight polymeric materials, which have higher performance areas with greater weight saving potential, has been limited by high costs.

## **5.6 Tolerances analysis and cost evaluation**

According to variability of the manufacturing process makes most of the characteristics of the product different, it becomes a quality loss in produced component. The more quality loss of the product occurs, the more variability of the product characteristics increases (Di Stefano, 2006). Therefore, limiting process variability results an increase in the manufacturing cost.

Process variables in the design stage are the specifications for the manufacturing process. Functional requirements of a design characteristic of a product are affected by design parameters, in which a target value and a design tolerance are included. In order to meet the design requirements, the maximum range of variation for a design parameter should be given in manufacturing qualified products.

## **5.7 Conclusion of Cost analysis**

To be concluded the cost analysis, the processing and material cost is the main factor for designing manufacturing of plastic compressor housing. As we discussed above, the cost of the selected material and production method can be very high. However, there can be a possible way to make it a balance between the advantages and disadvantages of the process. For instance, the cost of injection moulding machine can cost a fortune meanwhile it is still cost-effective if the manufacturing process is designated for mass production.

## Chapter 6

### Summary of Compressor Housing Requirements

---

#### 6.1 Behaviour of compressor housing under loading conditions

When the speeds and temperature reached by compressor wheels, the strength limit of the material becomes crucial for durability and safety. And the mechanical properties of polymers change with time under an applied load, therefore time-dependent material behaviour is generally needed to be characterized. In this project, the original casing geometry from BorgWarner was used in order to learn FEA static structural analysis by using different type of materials. Despite the fact that detail analysis of FEA structure is not done, the initial part of simulation is done using BorgWarner compressor cover in order to investigate the clear insights of complex design component before completion of physical model.

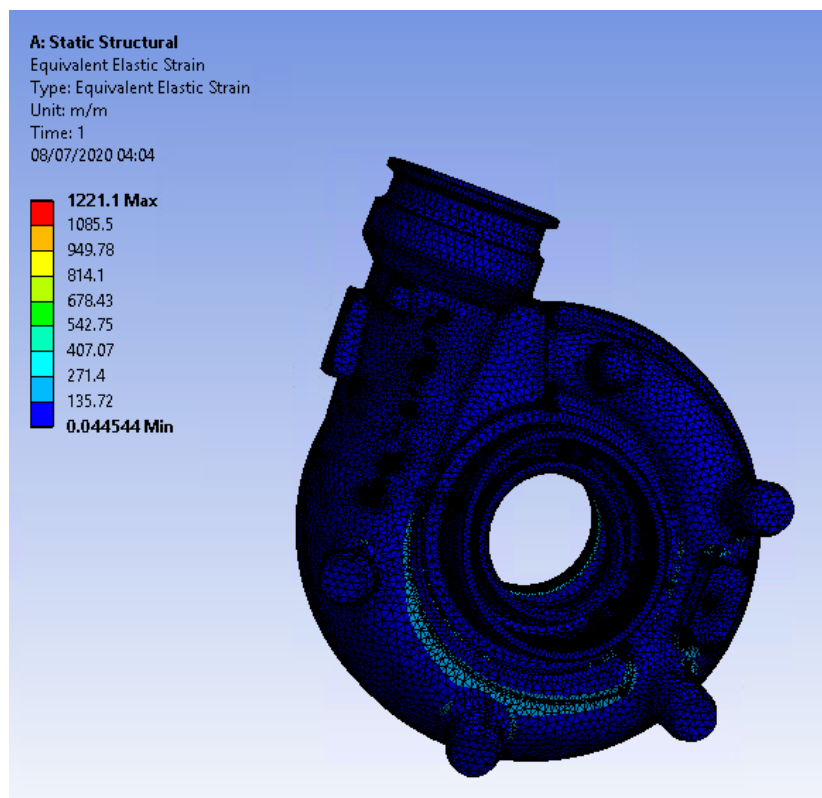
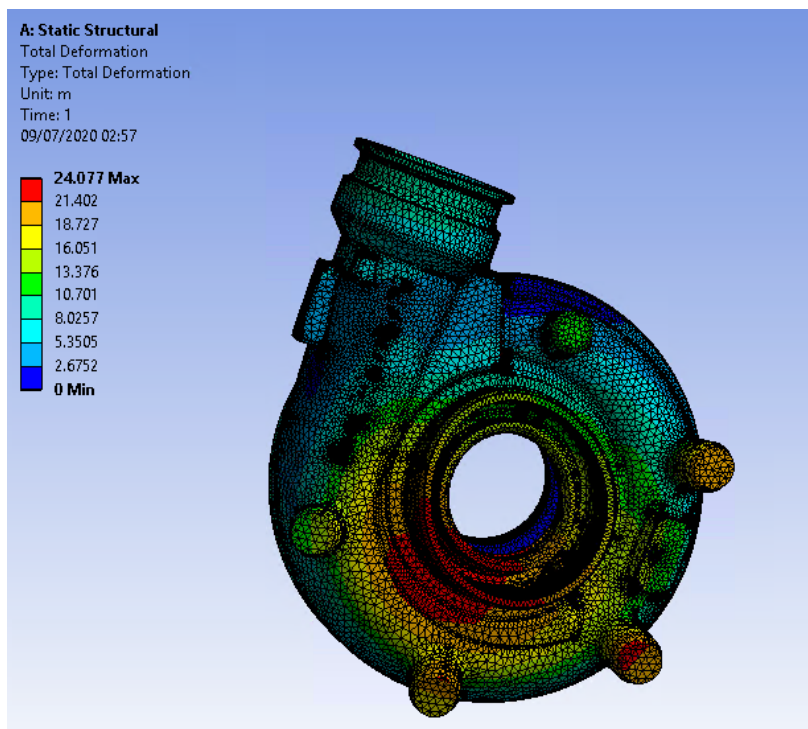
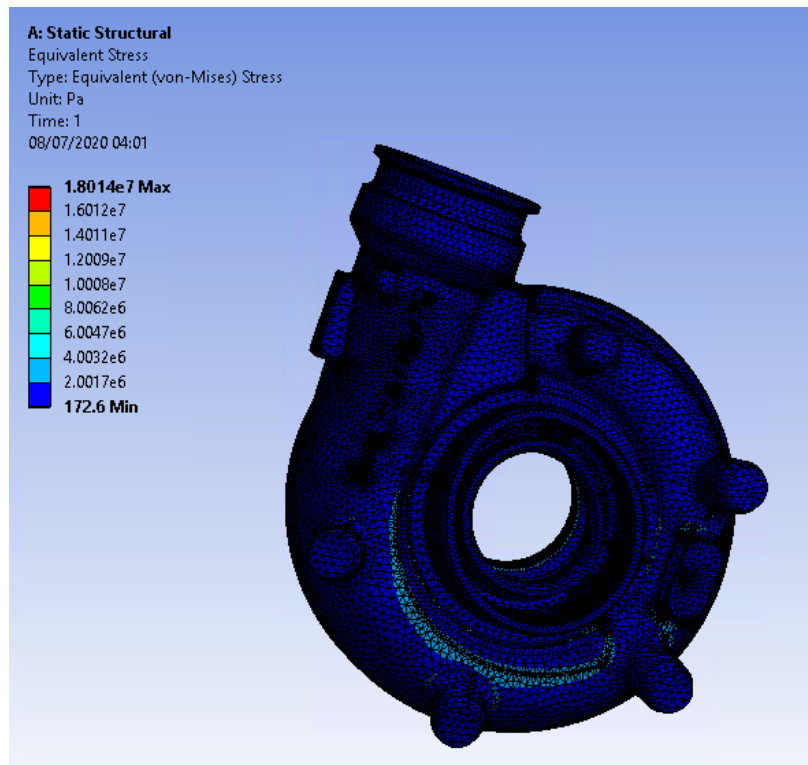

Figure 8: Structural analysis of original BorgWarner Casing



*Figure 8: Structural analysis of original BorgWarner Casing*

One of the significant finding from this FEA analysis is that there is some limitation of spontaneous deformation in most of the polymeric materials. Due to the increasing strain range, visco-elastic deformation processes are discovered. The deformation process increase

remarkably nonlinear. This experience notifies that it is less possible to demonstrate in the same way of stress-strain experiments like other linear materials in which the Hooke's law is obeyed. Therefore, the design calculation is definitely needed to justify in the case of thermoplastic polymeric material according to nonlinear deformation behaviour.

## 6.2 Moulded-Part Design Complexity

In the production of turbocharger compressor housing, it is necessary to follow the inspection requirements to verify the production housings retain equivalent material quality and dimensional accuracy to the housing which is utilized in the test. In the designing procedure of the compressor housing, the input parameters and the compressor geometry are basically required. Accordingly, the constraints given as design parameters are the inlet conditions such as ambient static pressure and temperature, maximum rotational speed, air mass flow rate and pressure ratio.

*Table 21-Operation conditions for compressor (Alshammari et al., 2019)*

Input Parameters	Metric Units
Ambient Static Pressure	2.5 bar
Ambient Static Temperature	295.15K
Maximum Rotational Speed	120,000 rpm

*Table 22-Experimental data of turbocharger (Alexander Mankin, 2014)*

	Governed Speed	Maximum Power	Peak Torque
Engine Speed	2,600 RPM	2,400 RPM	1,800 RPM
Output Power	235 kW	242 kW	192 kW
Torque	862 N-m	964 N-m	1,017 N-m
Inlet Air Flow	286 L/s	268 L/s	189 L/s
Change Air Flow	19.6 kg/min	18 kg/min	13 kg/min
Exhaust Gas Flow	564 L/s	554 L/s	438 L/s
Exhaust Gas Temperature	510°C	522°C	499°C
Heat Rejection to Coolant	138 kW	143 kW	107 kW
Radiator Coolant Flow	4 L/s	3.7 L/s	2.8 L/s
Turbo Comp. Outlet Pressure	188 kPa	195 kPa	161 kPa
Turbo Comp. Outlet Temperature	172°C	178°C	162°C

A rough idea of proposing the plastic compressor housing design will be analysed in terms of some parameters which are essential for compressor conditions. The housing strength is partially determined by the shape and thickness. We will discuss how the design is being approached for plastic casing in terms of constraints such as ribs, drafts, wall thickness and mould shrinkage.

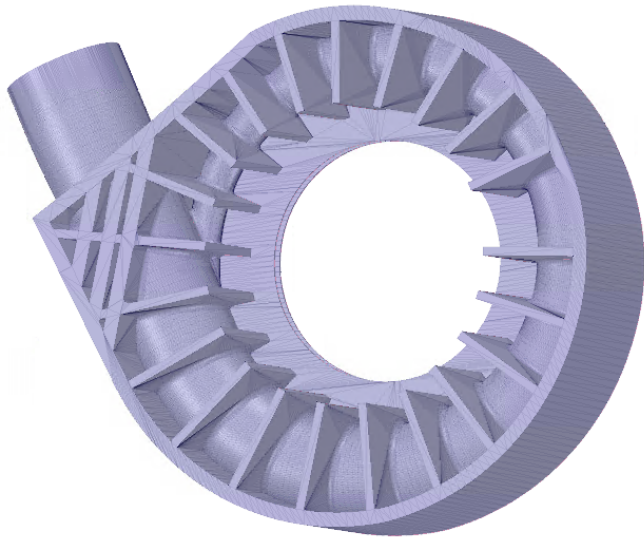

*Figure 9: Front view of variable geometry for plastic compressor design*

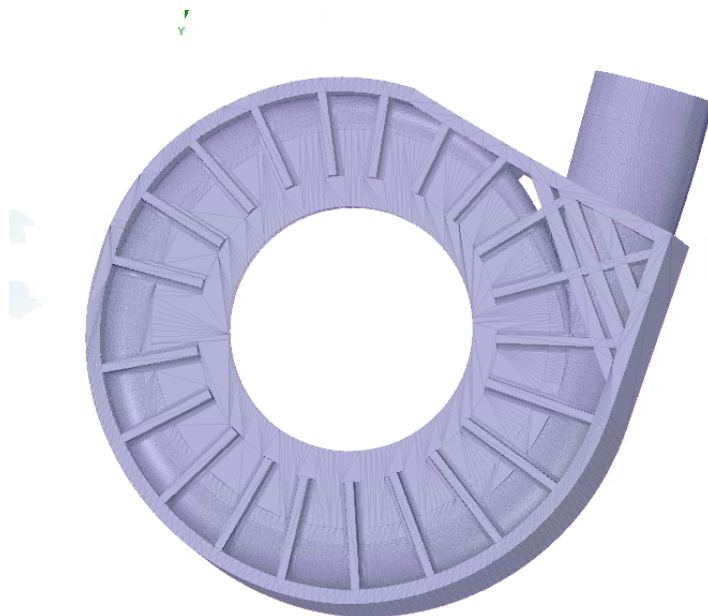

*Figure 10: Back view of variable geometry for plastic compressor design*

During designing process of injection moulded thermoplastic parts, the product designer must consider about some part configurations which can lead potential problems. Basic design requirements include wall thickness, Draft walls, parting plane, sharp corners, bosses and cored holes, and ribs, etc.

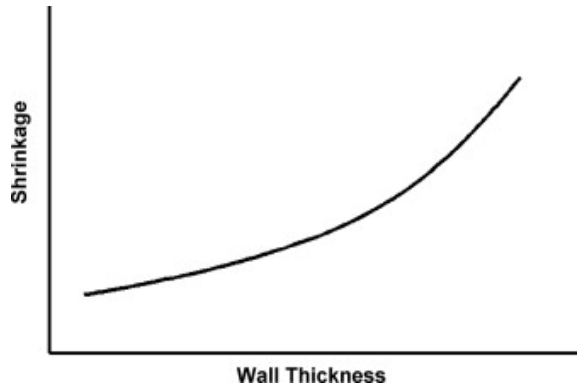

Figure 11: Relation between Shrinkage and Thickness(Campo, 2006b)

When the part is designed with two or more adjoining walls of different thickness, it is essential to consider about the shrinkage because most of thermoplastic material are semi-crystalline. The greater thickness the wall is, the greater shrinkage will result and more time is required for cooling.

In the proposed design, the part is designed with ribs for the structural rigidity. Secondly, ribs are added with round corners at the base of the ribs in order to enhance smoother filling which minimize consequent problems from abruptly changing contours. Third, draft angle are designed at least  $1/2^\circ$  and  $1.5^\circ$  for thermoplastic polymers because they have lower moulding shrinkage.

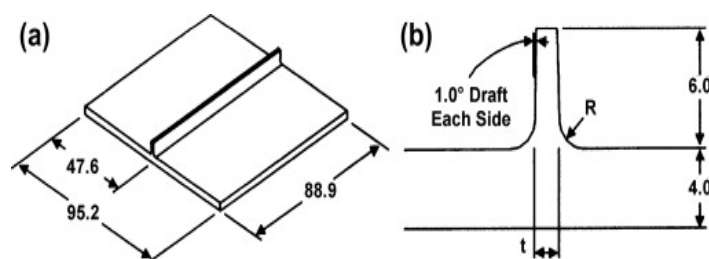

Figure 12: Draft Angle(Campo, 2006b)

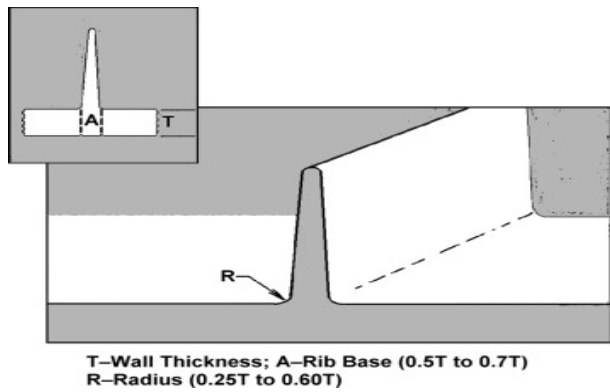

Figure 13: Ribs, Wall Thickness and draft angle of the part design(Campo, 2006b)

### 6.3 Conclusion of compressor housing requirements

As the proposed ideas of this project, the development activities of plastic compressor housing are analysed based on the meeting the criteria of the compressor housing in this chapter. All the measurements are done by analysing on previous findings and available materials data. Due to the fact that the particular type of compressor housing component with high complexity, detail mathematical modelling and simulation was not taken place according to the lack of properties data of thermoplastic materials, manufacturing facilities and expensive cost. However, future recommendation and product development will be discussed.

## Chapter 7

### Discussion and Future Recommendation

---

#### 7.1 Final analysis of material selection

The number of properties needed by the functions of a compressor housing were analysed on the fourth chapter called material selection in order to narrow down the selection of the appropriate materials. Moreover, it is necessary to define the specific type of polymer among the selected high performance materials for automotive applications.

Selecting housing material takes into consideration of the yield strength, ultimate tensile strength, and elongation percentage of the particular material. During choosing housing materials, it is important to look at not only the strength but also ductility and impact resistivity of the material. For instance, if the material strength is enough to be strong but brittle, it can break into pieces upon impact test and it would not be able to absorb the burst energy of the compressor wheel fragments without breaking.

Regarding of the dimensional accuracy of the compressor housing under high temperature conditions (200°), a component material needs to meet the requirements such as high dimensional stability, high aging stability under high temperature, thermal expansion properties similar to the material which will be replaced and low creep characteristics.

As the turbocharger compressor outlet temperature is not exceeding 200 °C, the polymers which has very high melting point will not be considered because of their design complexity and processing conditions. However, the dynamic pressure loads at high compressor outlet temperatures can create very particular requirements for the constructions and materials.

Materials	Overview			Price (GBP/Kg)	Physical Properties	Mechanical Properties					Impact Properties		Thermal Properties (°C)					Processing Properties			Recyclability
	Material Family	Base Material	Polymer code			Density(Kg/m <sup>3</sup> )	Young's Modulus modulus (GPa)	Yield Strength (MPa)	Tensile Strength (MPa)	Elongation % strain	Fatigue strength (MPa)	Fracture Toughness (MPa.m <sup>0.5</sup> )	Toughness (kj/m <sup>2</sup> )	Melting Point	Glass Temperature	Max Service Temperature	Min Service Temperature	Thermal Expansion Coefficient	Polymer Injection moulding	Polymer extrusion	
PI	Thermoset	PI(Polyimide, aromatic)	PI	29.1 - 31.6	1.5e3- 1.8e3	2.44 - 2.56	72- 158	72- 158	0.93 - 1.08	28.8 - 63.2	4.86 - 10.6	10.6 - 40.1	-	240 - 327	250 - 271	- 248- -238	27- 90	N	N	N	N
PI	Thermoplastic, amorphous	PI(Polyimide, aromatic)	PI	44.2 - 47.8	1.33e3- 1.43e3	2.07 - 2.76	86.2- 89.6	72.4 -118	7.5- 90	45- 50	2.16 -6.4	2.36 - 14.2	375 - 401	240 - 260	221 - 241	- 248- -238	81- 10 1	Y	Y	N	Y

Table 23 Comparative properties of selected thermoplastic materials (data from various resources)

Table 23 (Continued)

PEEK	Thermoplastic, Semi-crystalline)	PEEK	PEEK	75.3	1.3e3-1.32e3	3.76-3.95	87-95	70.3-103	30-150	28.1-41.2	2.73-4.3	2.02-4.6	322-346	143-157	239-260	-70-50	50-60	Y	Y	Y	Y
PBI	Thermoplastic, Semi-crystalline)	Polybenzimidazole	PBI	135-152	1.29e3-1.31e3	5.8-5.9	130-160	130-160	2.9-3.1	54.6-57.4	1.5-2	0.39-0.672	590-592	425-427	302-318	-51-48.8	23-25	N	N		N
PPS	Thermoplastic, Semi-crystalline)	Polyphenylene sulphide	PPS	5.11-5.81	1.34e3-1.36e3	3.23-3.39	64-67.2	48.3-86.2	1-6	19.3-34.5	1.23-1.75	0.46-0.9	285-290	81-97	250-271	-55-35	48.6-88.2	Y	Y	Y	Y

The comparative properties between three different materials are the data analysis result among selected five different polymers by the Pugh screening method, which is shown in the following table.

Table 24-Comparative properties between Aluminium Alloy and Based polymers (data from various resources)

Properties	Aluminium Alloy	PEEK	PPS
Density	2.77g/cc	1.33g/cc	1.33g/cc
Young's Modulus	71 GPa	3.90GPa	3.12GPa
Tensile Yield Strength	280MPa	97.7MPa	64-67.2MPa
Tensile Ultimate Strength	310MPa	99.1MPa	114MPa
Elongation at break	$\geq 3.0\%$	24.70%	21.20%
Thermal Conductivity	167W/m-K	0.293W/m-K	0.256 W/m-K
Melting Point	677-816°C	373°C	309°C
Specific Heat	0.963J/g-°C	1.57J/g-°C	1.33J/g-°C

PEEK and PPS have similar characteristic of existing aluminium alloy which is commonly used in the compressor housing. The main advantages of both polymers is their high strength at increasing temperature and the water absorption of PEEK of 0.182% and that of PPS is 0.0617%. It means that these polymers are dimensional stable even with large fluctuations in temperature and humidity.

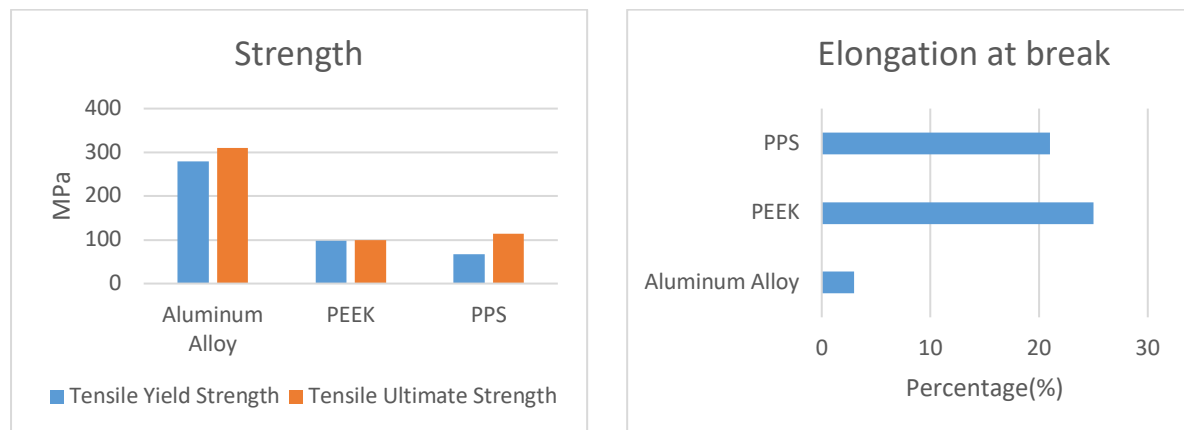

Figure 14: Strength Comparison between Aluminium Alloy and Base Polymers at room temperature

According to the above comparative graphs, it is clearly shown that the strength of base polymer is lower than aluminium alloy and it is less likely to use in the application of strong loading conditions like compressor housing. Therefore, the polymer will be filled with carbon in order to increase the overall mechanical strength. The properties of reinforced polymers will be analysed as follow.

Table 25-Comparative properties between reinforced polymers (data from various sources)

	Carbon Reinforced PEEK	Carbon Reinforced PPS
Filler content (%)	28.80%	31.30%
Density(g/cc]	1.44	1.48
Tensile Strength( Mpa)	258	168
Elongation at Break (%)	1.89	1.23
Flexural Modulus (GPa)	21.4	21
Izod notched Impact Strength (J/cm)	0.681	0.617
HDT/A (1.8 Mpa)(°C)	296	264
Melting Point(°C)	342	279
Maximum Service Temperature (°C)	261	200

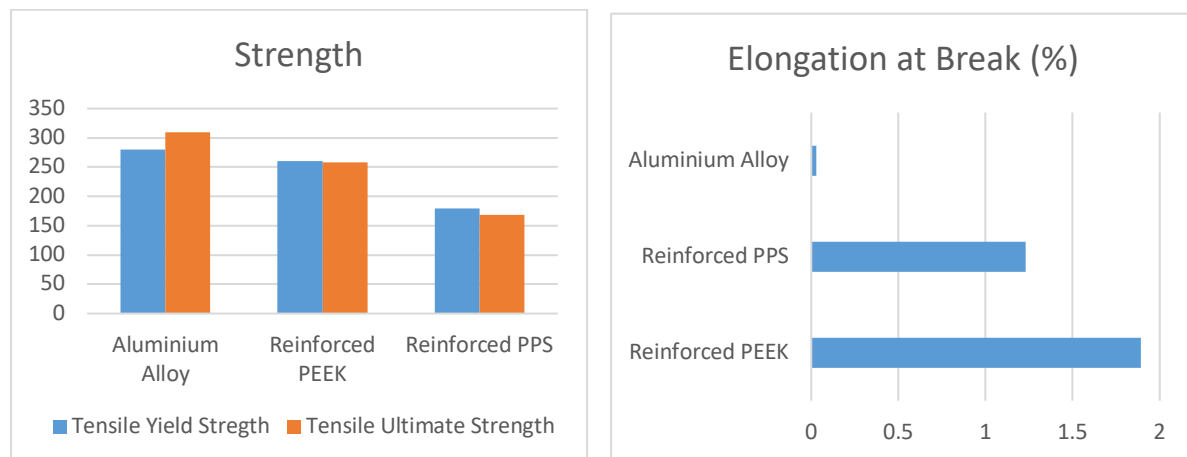

Figure 15: Comparison of strength and elongation of between Aluminium alloy and reinforced polymers

According to the comparison between the reinforced polymers and aluminium alloy, the strength has been increased due to the carbon fibre reinforcement. However, there is an important consideration dealing with the yield strength which can decrease at the elevated temperature.

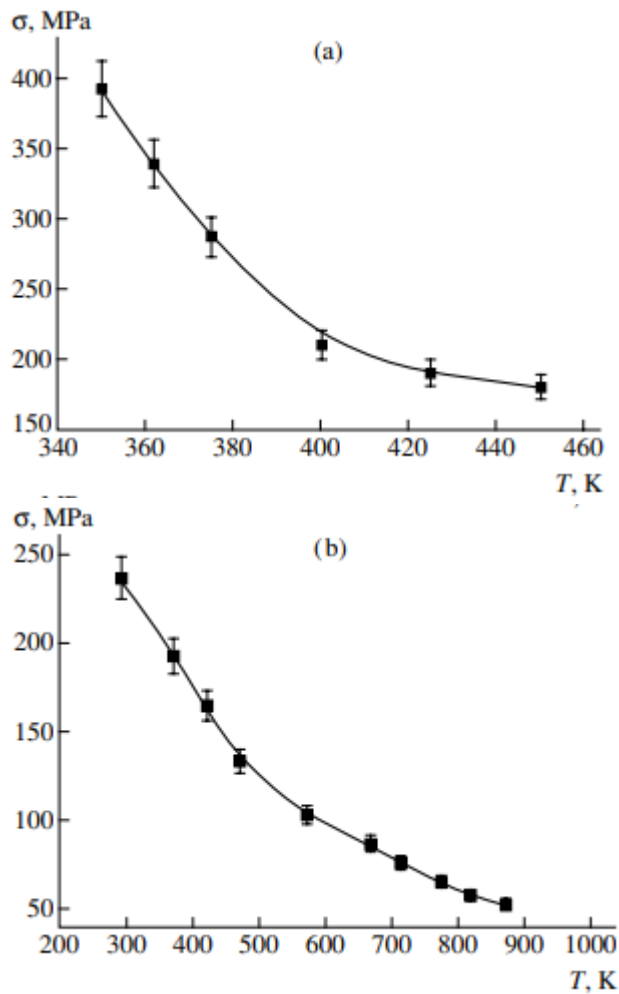

Figure 16: Dependence of Strength of aluminium alloy and polymers at elevated temperature (a) Polymer (b) Aluminium Alloy (V. I. Vettegreña, 2005)

According to the above comparative study of the relationship between yield strength and elevated temperature of different materials, it is clearly shown that the yield strength of the polymeric material is between 250 MPa at the temperature around 400 K (127 °C) while that of aluminium alloy is from 150 MPa and 200 MPa at the same temperature. After that, the strength of aluminium alloy is dramatically decreased as it is shown in figure (b). However, the strength of polymer will remain steady throughout elevated temperature while that of aluminium alloy decrease highly as the temperature increases. Therefore, the polymer has more consistent strength than aluminium alloy at the steadily increasing temperature environment.

Carbon Reinforced PEEK and PPS are found to be suitable alternative materials among selected high performance thermoplastics which can withstand the severe environment. The data used in each steps of project are based on online data resources and previous findings. During the developing activities, the major steps involved are material selection process, manufacturing like injection molding process and last but not least cost analysis on a particular product. The finite element analysis was also involved in the learning of structural analysis.

For the future reference, the advantages of the part design, weight saving and environment friendly components outweigh than the the cost factor. However, there could always be a more effective method of cost reduction in replacing aluminium compressor housings.

## **7.2 Commercial feasibility of Manufacturing Methods for compressor covers**

The relationship between mould complexity and manufacturability cost is very challenging in the developing activities of compressor housing. Although it is possible to provide the proposed design idea of compressor cover, more mathematical modelling and calculation needs to be taken. Moreover, some other important factors such as commercial profitability and cost reduction need to be considered.

As high-performance nature of thermoplastic material, their processing cost is more expensive than metal. Accordingly, the alternative material should have more effective way and be satisfied than the current material in use. Due to basic design requirements of manufacturing method, the advantages of the injection moulding process outnumber among all of the processing method if there is a possible way to provide design process for mass production. It is because equipment and tooling cost are very high because of dies which is needed to be made from hardened tool steel.

## **7.3 Recommendation for future**

First of all, it is essential to have the input data of materials for further simulation and the equipment required to test the selected material research. After finishing initial assessment in the design process of prototype with examples of data proposed, creating physical prototype is the next step to be conducted. After that, an investment evaluation of manufacturing facility plan can be performed.

The objectives of this research were to investigate into the use of high temperature resistant polymers in the turbocharger compressor cover and to provide a comparison of material choices and manufacturing methods. In the selecting of a suitable alternative material, the developing activities are very challenge because of selecting an alternative form of processing as well as calculating the manufacturing costs. From the price data from the international market, PPS and PEEK itself are three times more expensive than the current material, but the high-volume manufacturing could be cheaper because some automotive

plastic parts are focused for cost effectively manufacturing and the advantages of weight saving is around 30% and carbon emission will be reduced significantly.

To be concluded, during investigating into the injection moulded thermoplastic parts in the turbocharger, several ideas were collected from the analysis. The collective material data throughout this research can be used for the future calculation and simulation in designing process with thermoplastic polymer products. In further research study, it is also possible to plan material research and development by reinforcing materials for the better outcome of final products and testing activity can be performed.

## List of References

- 1) Agazzi, A., Sobotka, V., LeGoff, R., & Jarny, Y. (2013). Optimal cooling design in injection moulding process – A new approach based on morphological surfaces. *Applied Thermal Engineering*, 52(1), 170-178. <https://doi.org/10.1016/j.applthermaleng.2012.11.019>
- 2) Al-Rousan, R. Z., Shbeeb, N. I., & Al-Masri, R. (2016). Nonlinear finite element analysis of thermoplastic railroad bridge. *Journal of Thermoplastic Composite Materials*, 29(6), 850-866. <https://doi.org/10.1177/0892705716632859>
- 3) Mankin, A., Mclarty, H., Scott, R., & Oluwalowo, A. (2013). Final Presentation. Retrieved 11 December 2019, from <https://studylib.net/doc/5497776/final-presentation>
- 4) Alshammari, M., Xypolitas, N., & Pesyridis, A. (2019). Modelling of electrically-assisted turbocharger compressor performance. *Energies (Basel)*, 12(6), 975. <https://doi.org/10.3390/en12060975>
- 5) Ashby, M. F. (2011;2010;). *Materials selection in mechanical design* (4th ed.). Butterworth-Heinemann.
- 6) Asiedu, Y., & Gu, P. (1998). Product life cycle cost analysis: State of the art review. *International Journal of Production Research*, 36(4), 883-908. doi:10.1080/002075498193444
- 7) Baird, D. G., & Collias, D. I. (2014). *Polymer Processing : Principles and Design*. Somerset, UNITED STATES: John Wiley & Sons, Incorporated.
- 8) Biron, M. (2018). 5. Thermoplastic Processing. In *Thermoplastics and Thermoplastic Composites (3rd Edition)*: Elsevier.
- 9) Bonten, C. (2019). 5.2.6 Importance for the Choice of the Processing Method. In *Plastics Technology - Introduction and Fundamentals*: Hanser Publishers.
- 10) Campo, E. A. (2006a). 10.1 Classification of Injection Molds. In *Complete Part Design Handbook - For Injection Molding of Thermoplastics*: Hanser Publishers.
- 11) Campo, E. A. (2006b). *The complete part design handbook : for injection molding of thermoplastics*. Place of publication not identified: Hanser Gardner Publications.
- 12) Campo, E. A. (2016). 12. Thermoplastic Product Cost Analysis. In *Complete Part Design Handbook - For Injection Molding of Thermoplastics*: Hanser Publishers.
- 13) Chen, Y.-M., & Liu, J.-J. (1999). Cost-effective design for injection molding. *Robotics and Computer Integrated Manufacturing*, 15(1), 1-21. doi:10.1016/S0736-5845(99)00005-8

- 14) Dean, G. D., McCartney, L. N., Mera, R., & Urquhart, J. M. (2011). Modeling nonlinear viscoelasticity in polymers for design using finite element analysis. *Polymer Engineering & Science*, 51(11), 2210-2219. doi:10.1002/pen.21993
- 15) DeMeuse, M. T. (2014). 7.3 PBI Blends. In *High Temperature Polymer Blends*: Elsevier.
- 16) Di Stefano, P. (2006). Tolerances analysis and cost evaluation for product life cycle. *International Journal of Production Research*, 44(10), 1943-1961. doi:10.1080/00207540500465832
- 17) Dunk, A. S. (2004). Product life cycle cost analysis: The impact of customer profiling, competitive advantage, and quality of IS information. *Management Accounting Research*, 15(4), 401-414. <https://doi.org/10.1016/j.mar.2004.04.001>
- 18) Dupont. Innovative ideas for metal replacement. (2019). Retrieved 16 February 2020, from <https://www.dupont.com/knowledge/innovative-ideas-for-metal-replacement.html>.
- 19) Fink, J. K. (2008). 5.7.2 Abrasion-Resistant Poly(tetrafluoroethylene) Blends. In *High Performance Polymers (2nd Edition)*: Elsevier.
- 20) Garcia-Leiner, M., Reitman, M. T. F., El-Hibri, M. J., & Roeder, R. K. (2017). Structure-property relationships in commercial polyetheretherketone resins. *Polymer Engineering & Science*, 57(9), 955-964. doi:10.1002/pen.24472
- 21) Gerdeen Pe, J. C., & Rorrer Pe, R. A. L. (2011). *Engineering Design with Polymers and Composites*. Boca Roca, UNITED STATES: Taylor & Francis Group.
- 22) Gilbert, M. (2017). 9.2.5.4 The Injection Mold. In *Brydson's Plastics Materials (8th Edition)*: Elsevier.
- 23) Hergenrother, P. M. (2003). The Use, Design, Synthesis, and Properties of High Performance/High Temperature Polymers: An Overview. *High Performance Polymers*, 15(1), 3-45. doi:10.1177/095400830301500101
- 24) Ibeh, C. C. (2011). *Thermoplastic Materials : Properties, Manufacturing Methods, and Applications*. Baton Rouge, UNITED STATES: Taylor & Francis Group.
- 25) Irisarri, F. X., Macquart, T., Julien, C., & Espinassou, D. (2019;2018;). A novel design method for the fast and cost-effective manufacture of composite parts employing the quilted stratum process. *Composites. Part B, Engineering*, 158, 364-372. <https://doi.org/10.1016/j.compositesb.2018.09.070>
- 26) Ishikawa, T., Amaoka, K., Masubuchi, Y., Yamamoto, T., Yamanaka, A., Arai, M., & Takahashi, J. (2018). Overview of automotive structural composites technology developments in Japan. *Composites Science and Technology*, 155, 221-246. doi:10.1016/j.compscitech.2017.09.015

- 27) Karthikeyan, R. K. (2010). *Process planning for rapid manufacturing of plastic injection mold for short run production*. Iowa State University,
- 28) Liaw, D.-J., Wang, K.-L., Huang, Y.-C., Lee, K.-R., Lai, J.-Y., & Ha, C.-S. (2012). Advanced polyimide materials: Syntheses, physical properties and applications. *Progress in Polymer Science*, 37(7), 907-974. doi:10.1016/j.progpolymsci.2012.02.005
- 29) Mastro, P. F. (2016). *Plastics Product Design*. Hoboken, UNITED STATES: John Wiley & Sons, Incorporated.
- 30) Mavrontontis, N. (2017). Converting Engineering Stress-Strain to True Stress-Strain in Abaqus [Blog]. Retrieved from <https://info.simuleon.com/blog/converting-engineering-stress-strain-to-true-stress-strain-in-abaqus>
- 31) McKeen, L. W. (2019). *The effect of UV light and weather on plastics and elastomers* (Fourth ed.). Cambridge, MA: Elsevier.
- 32) Osswald, T., & Hernández-Ortiz, J. P. (2017). 3. Polymer Processes. In *Polymer Processing - Modeling and Simulation*: Hanser Publishers.
- 33) Pfeifer, M. (2009). *Materials enabled designs: the materials engineering perspective to product design and manufacturing*. Amsterdam; Boston; Butterworth-Heinemann.
- 34) Folgado, R., Peças, P., & Henriques, E. (2010). Life cycle cost for technology selection: A case study in the manufacturing of injection moulds. *International Journal of Production Economics*, 128(1), 368-378. <https://doi.org/10.1016/j.ijpe.2010.07.036>
- 35) Rauwendaal, C. (2014). 9.1 Basic Considerations. In *Polymer Extrusion (5th Edition)*: Hanser Publishers.
- 36) Rogers, M. (1995). *High Temperature Properties and Applications of Polymeric Materials* (1st ed., pp. 1-20). American Chemical Society.
- 37) Sathishkumar, T., Satheeshkumar, S., & Naveen, J. (2014). *Glass fiber-reinforced polymer composites – a review*. SAGE Publications. <https://doi.org/10.1177/0731684414530790>
- 38) Setyowati, E., & Pandelaki, E. E. (2018). The concept of sustainable prefab modular housing made of natural fiber reinforced polymer (NFRP). *IOP Conference Series. Materials Science and Engineering*, 316(1), 12004. <https://doi.org/10.1088/1757-899X/316/1/012004>
- 39) Shehab, E. M., & Abdalla, H. S. (2001). Manufacturing cost modelling for concurrent product development. *Robotics and Computer Integrated Manufacturing*, 17(4), 341-353. doi:10.1016/S0736-5845(01)00009-6
- 40) Sidney Levy, J. H. D. (1984). *Stress-Strain Behavior of Plastics Materials*. Boston.

- 41) SpecialCham. (2020). High Temperature Thermoplastics-Comprehensive Guide. Retrieved from <https://omnexus.specialchem.com/selection-guide/high-temperature-thermoplastics>.
- 42) Swift, K. G. (2013). *Manufacturing process selection handbook* (1 ed.). Oxford: Elsevier.
- 43) Tan, W., & Falzon, B. G. (2016). Modelling the nonlinear behaviour and fracture process of AS4/PEKK thermoplastic composite under shear loading. *Composites Science and Technology*, 126, 60-77. doi: 10.1016/j.compscitech.2016.02.008
- 44) Tres, P. A. (2017). *Designing Plastic Parts for Assembly* (8th Edition). In: Hanser Publishers.
- 45) Turc, C., Cărăușu, C., & Belgiu, G. (2017). Cost analysis in injection moulded plastic parts designing. *IOP Conference Series. Materials Science and Engineering*, 227(1), 12132. <https://doi.org/10.1088/1757-899X/227/1/012132>
- 46) Vettegren, V. I., Kulik, V. B., & Bronnikov, S. V. (2005). Temperature dependence of the tensile strength of polymers and metals at elevated temperatures. *Technical Physics Letters*, 31(11), 969-972. <https://doi.org/10.1134/1.2136968>
- 47) Guo, W., Guo, H., Du, X., & Wang, D. (2014). *Turbine Housing Boss Design in Turbocharger Application* [Ebook]. SAE International. Retrieved 16 February 2020, from <https://doi.org/10.4271/2014-01-2849>.
- 48) Wilczyński, K., Nastaj, A., Lewandowski, A., Wilczyński, K. J., & Buziak, K. (2019). Fundamentals of Global Modeling for Polymer Extrusion. *Polymers*, 11(12), 2106. doi:10.3390/polym11122106
- 49) Witik, R. A., Payet, J., Michaud, V., Ludwig, C., & Manson, J.-A. E. (2011). Assessing the life cycle costs and environmental performance of lightweight materials in automobile applications. *Composites Part A*, 42(11), 1694-1709. doi: 10.1016/j.compositesa.2011.07.024
- 50) Feng, X., & Liu, J. (2018). Thermoplastic polyimide (TPI). In V. PM, & S. AO (Eds.), (pp. 149-219). John Wiley & Sons, Inc. <https://doi.org/10.1002/9781119363910.ch6>
- 51) Yang, J., Wang, C. X., Yu, Z. S., Li, Y., Yang, K. K., & Wang, Y. Z. (2011). Impact behavior and fracture morphology of acrylonitrile-butadiene-styrene resins toughened by linear random styrene-isoprene-butadiene rubber. *Journal of Applied Polymer Science*, 121(4), 2458-2466. doi:10.1002/app.33773

- 52) Yoo, J., Choi, W., Lee, B., Kim, G., Kim, H., Choi, W., Oh, Y., & Lee, S. (2019). Replacement of ni by mn in commercial high-ni austenitic cast steels used for high-performance turbocharger housings. *Metallurgical and Materials Transactions. A, Physical Metallurgy and Materials Science*, 50(6), 2585-2593. <https://doi.org/10.1007/s11661-019-05205-0>
- 53) Zhou, H. (2013). *Computer Modeling for Injection Molding: Simulation, Optimization, and Control*. Somerset, UNITED STATES: John Wiley & Sons, Incorporated.