



University of HUDDERSFIELD

University of Huddersfield Repository

Chong, Kee Yong

Multi-layered ethnic and cultural influences in my musical compositions

Original Citation

Chong, Kee Yong (2016) Multi-layered ethnic and cultural influences in my musical compositions. Doctoral thesis, University of Huddersfield.

This version is available at <http://eprints.hud.ac.uk/id/eprint/31091/>

The University Repository is a digital collection of the research output of the University, available on Open Access. Copyright and Moral Rights for the items on this site are retained by the individual author and/or other copyright owners. Users may access full items free of charge; copies of full text items generally can be reproduced, displayed or performed and given to third parties in any format or medium for personal research or study, educational or not-for-profit purposes without prior permission or charge, provided:

- The authors, title and full bibliographic details is credited in any copy;
- A hyperlink and/or URL is included for the original metadata page; and
- The content is not changed in any way.

For more information, including our policy and submission procedure, please contact the Repository Team at: E.mailbox@hud.ac.uk.

<http://eprints.hud.ac.uk/>

**MULTI-LAYERED ETHNIC AND CULTURAL INFLUENCES IN MY
MUSICAL COMPOSITIONS**

KEE YONG CHONG

A thesis submitted to the University of Huddersfield
in partial fulfilment of the requirements for
the degree of Doctor of Philosophy

University of Huddersfield
CeReNeM, Centre for Research in New Music

July 2016

Table of Contents

Table of Contents	3
Copyright statement	5
Acknowledgements	7
Abstract	9
Chapter I. Introduction	11
1. East and Southeast Asian traditions	11
2. East-West intercultural exchange	13
3. Oral traditions	14
4. Vocalisation	15
5. Developing a personal style from the formal elements of Asian music	18
6. Collaboration	19
Chapter II. Influences of Chinese cultures and heritage on my composition	21
1. <i>Shui.Mo</i> 水。墨 (2007)	21
2. <i>Bie Ge</i> 別歌 (2012)	27
3. <i>Xun Feng</i> 尋風 (2013)	36
4. <i>Yun Yong</i> 雲湧 (2011)	42
5. <i>Timeless echoes</i> (2010)	48
Chapter III. My compositional philosophy and approach to an East-West aesthetics of today	55
1. “Water-image” symmetry	65
2. Coordinated control of articulation, inflections in pitch, ornamentation, timbre, and intensity in my compositions	70
3. Tuning systems	72
4. Use of vocalisation	79
5. Teacher-student mentorship in the study of music: Interplay and interchange of roles	82
6. Transformation of the standard instrumental setup to a more complex spatialisation in order to create greater sonic mobility in my compositions	86
Chapter IV. Conclusion	93
Appendix A. Lecture paper: Inspiration from Chinese cultural sources and Western contemporary musical techniques in my compositional practices	97
1. Introduction	97
2. <i>Metamorphosis VI-Wind prayer</i>	98
2.1. Instrumental setup and the soundscape of moving wind	98

2.2. Use of the 37-reed soprano sheng -----	99
2.3. Use of the gu zheng -----	101
2.4. Integration of the sheng, gu zheng, and pipa -----	105
3. <i>Endless whispering</i> -----	108
3.1. Instrumental setup -----	108
3.2. Playing techniques of the 37-reed soprano sheng in <i>Endless whispering</i> -----	110
4. <i>Horizon's chant</i> -----	114
4.1. Instrumental setup -----	115
4.2. Performing techniques applied in <i>Horizon's chant</i> -----	116
5. <i>Shui.Mo</i> 水。墨 (Water.Ink) -----	118
5.1. Spatialisation: Sonic mobility and possibilities created by instrumentation and instrumental setup -----	118
5.2. Performing techniques for the Chinese instruments in <i>Shui.Mo</i> -----	120
5.3. Orchestral instrumentation and echo effects in <i>Shui.Mo</i> -----	123
6. Summary -----	127
Bibliography -----	129
1. Cited references -----	129
2. General bibliography of books, articles and music scores -----	132
List of figures -----	139
Glossary -----	145
Portfolio of compositions -----	151
Accompanying compact discs: Track details -----	155
Supporting materials to Chapter III & Appendix A -----	157
Biography -----	159
Complete list of compositions (2010–2015) -----	161
Word count (excluding appendices but including footnotes):	18,824

Copyright statement

i. The author of this thesis (including any appendices and/or schedules to this thesis) owns any copyright in it (“the copyright”) and he has given The University of Huddersfield the right to use such Copyright for any administrative, promotional, educational and/or teaching purposes.

ii. Copies of this thesis, either in full or in extracts, may be made only in accordance with the regulations of the University Library. Details of these regulations may be obtained from the Librarian. This page must form part of any such copies made.

iii. The ownership of any patents, designs, trademarks and any and all other intellectual property rights for the Copyright (the “Intellectual Property Rights”) and any reproductions of reproductions of copyright works, for example graphs and tables (“Reproductions”), which may be described in this thesis, may not be owned by the author and may be owned by third parties. Such Intellectual Property Rights and Reproductions cannot and must not be made available for use without the prior written permission of the owner(s) of the relevant Intellectual Property Rights and/or Reproductions.

Acknowledgements

This study has been realised with the help and support of the following individuals and organisations:

I am deeply grateful to the University of Huddersfield for funding my study in this PhD by publication program with a full fee waiver scholarship. I would also like to thank my supervisor, Prof. Liza Lim, for the countless hours of support, advice, patience, inspiration, and encouragement she has kindly offered me during my intensive one-year doctoral study. This document also owes its existence to my mentors Prof. Wen Chung Chou and late Prof. Yu Yan Rao, who inspired me to compose music that is deeply rooted in my own cultural legacy. Without them, I might never have been able to pursue my musical journey.

I would like to express great appreciation to musicians Mr. Wei Wu and Ms. Feng Xia Xu for first introducing their instruments, the traditional 37-reed soprano sheng and gu zheng, to me. I learnt so much from their insightful knowledge of traditional and contemporary music and their creative ways of merging Eastern and the Western musical elements in our collaborations.

Enormous thanks are also due to the many performers and ensembles with whom I have had the privilege of working with for my compositions, and the many festivals that have programmed my music: Yoshiko Hannya, Wei Wu, Xiao Fen Min, Feng Xia Xu, Ed Spanjaard, Joël Bons, Ya-Ou Xie, Juan-Reng Yeh, Chung-Hsien Wu, Lung-Yi Huang, Chen-Ming Huang, Emilie-Anne Gendron, Adda Kridler, Stephanie Griffin, Michael Haas, Bor-Nien Hsu, Yun-Hung Chen, Arne Deforce, Sigrid Tanghe, Jean Marc Sullon, Bart Bouckaert, Jonas Alber, Nieuw Ensemble (the Netherlands), Ensemble Berlin PianoPercussion (Germany), Dragon Ensemble (Germany), Symfonie Orkest Vlaanderen (Belgium), ensemble Het Collectief (Belgium), Chai Found Music Workshop (Taiwan), The Serge Koussevitzky Music Foundation (USA), Momenta Quartet (USA), Forum Music Percussion ensemble (Taiwan), Taipei Chamber Singers (Taiwan), Centre Henri Pousseur (Belgium), and last but not least the Centre for Research in New Music at the University of Huddersfield (UK).

I must express my deepest gratitude to Kelly Poyu Chen, Ruo Xian Gan, and Tshiung Han See for their editorial assistance; to my friend Hong Chuan Thor who financially supports my trips to Huddersfield and the double-compact-disc production; to Yuan Shun Ong and Chow Shern Yeo for editing the audio recording; and to Tsu Ji Lam for designing the album of the double-compact-disc production for my portfolio.

Finally, and most important, I am grateful to my parents and family members—Ka Ling, Chuan Yi, and Chuan Le—for their unrelenting patience, support, and love that they have tirelessly given me throughout this period of my life.

This work would not exist without all the above mentioned people.

Abstract

In this doctoral thesis, I examine the influence of multi-ethnic cultures and heritage of East and Southeast Asia on my compositional development. Although the imitation of the outward features of other cultures is an important part of the attempt to compose cross-cultural pieces, such imitation is only one part of the learning process. The most difficult task is to make a meaningful cultural confluence out of these influences. My original contribution to music lies in the way in which I have activated the legacy of my multicultural Malaysian heritage and combined a strong focus on Chinese cultural traditions with a wider Malaysian context that involves theatre, philosophy, rituals, and spirituality.

Over the past few years, I have composed cross-cultural works for traditional East and Southeast Asian and Western instruments, collaborating with multiple musicians in Asia, the United States, and Europe. The compositions discussed in this thesis reveal the various elements of my writing for Chinese instruments that are at once original and eclectic. I am particularly interested in incorporating various East and Southeast Asian musical practices such as Chinese dialect folk songs (especially Hakka storytelling and mountain songs), Gamelan music from South East Asia, Indian ritual and ceremonial music, ancient Chinese court music, and chanting of classical Chinese poetry, Korean Pansori music, and Japanese Gagaku music to create my own compositional techniques and languages. Using my compositions as examples, I illustrate the incorporation of East and Southeast Asian vocal and instrumental techniques into Western musical languages. In the first two chapters, I focus more on the importance of Chinese sources of poetry and philosophical thinking in a number of large-scale works. In the third chapter, I examine the key compositional roles played by elements such as sonic mobility and spatialisation, the interplay and interchange of roles in instrumental writing, and the concept of “living ornamentation” in creating heterophony and vocalisation, and present a detailed analysis of one of my works *Yuan-Liu* (2009). I explain how sonic mobility and spatialisation, as realised through unique instrumental setups in my compositions, are deeply informed by my childhood experience of listening to the acoustics of nature in the woods. In the concluding chapter, I discuss how I use the concepts of time, narrative, and cultural confluence in my music.

Keywords: multiculturalism, spatialisation, interplay and interchange of roles, living ornamentation, vocalisation, heterophony.

Chapter I. Introduction

1. East and Southeast Asian traditions

East and Southeast Asian traditions involve diverse religions and an emphasis on the concepts of home and family. Religious diversity and the emphasis on home and family can be exemplified by my experience in Malaysia.

I am a Malaysian-Chinese composer born in the small town of Kluang at the heart of Malaysia's southern palm-oil plantation state of Johor, where my parents worked as farmers. I grew up in a traditional Malaysian-Chinese farmer family. My grandparents were Hakka¹ immigrants from the Southern part of China. They worked at a rubber plantation to meet the needs of the British colonial economy created by the British in the Malay Peninsula around 1907. My maternal grandfather, master Sak, was known as the legendary Hakka mountain song (山歌)² singer and storyteller in our village, although he also worked as a private Chinese traditional medical doctor during his free time. My parents are the first generation born locally in Malaysia. My parents did not have proper education because of the Japanese occupation and the poverty they had faced. They had to work in a rubber plantation at the early age of twelve in order to earn their daily living to sustain their family.

I had a unique childhood. My childhood is mostly related to rubber, vegetable, coco, and a palm oil plantation owned by my family. This plantation is fifty km away from our house at the village of Kampung Paya in Kluang. When I was four years old, my parents would bring me along in their old car to their rubber plantation at 4 o'clock every morning. I would sleep in the small "pondok" (hut) at the plantation and start playing and frolicking around the plantation when I woke up. I remembered how enjoyable it was to play in the stream, catching little fishes and shrimps, laying down to see the clouds surging, hearing "dialogues" between a group of monkeys, the wind blowing past the bamboo vegetation and rock mountains, birds calling from afar. As a young boy, I found myself surrounded by the sounds of nature that echoed from the distance across the rubber plantation. Growing up in this rustic environment has left an indelible mark in my artistic outlook, where the sounds and wonders of nature have never ceased to inspire me.

¹ The Hakka people, literally meaning "guest people," are referred to as being spatially mobile (Hsieh, 1929, p. 202). The Hakka people came from Guangdong and Fujian provinces of China. Large numbers of Hakka migrated to Malaysia and worked as miners in the 19th century. Later, many turned to the rubber industry settled in Kedah and Johor (principally in Kulai and Kluang) as the mining industries declined in the 20th century ("Malaysian Chinese," n.d.).

² "Hakka mountain songs and folk songs play a unique role in traditional performing arts and social culture. During their migrations, Hakka people had always chosen to settle near mountains. Since farming has also been their primary means of livelihood, when they were trailblazing in mountains or working on the farm, their life was always closely related to nature. Mountain songs were created in mountains and open fields. They were improvisations by Hakka forebears while tilling the land or just having fun at leisure. They are mostly depictions of life and praises of love; the emotions of happiness, anger, sorrow and joy are completely expressed in these creations" (Hakka Affairs Council, 2006).

Malaysia is a multi-ethnic society and multi-cultural country, home to many ethnicities from different backgrounds. The Malays, Chinese and Indians, form the three largest ethnic groups of Malaysia. In 2010, Malays and other Bumiputera³ accounted for 67.4%, Chinese 24.6% and Indians 7.3% of the total population of Malaysia (Saw, 2015, p. 64). Languages used in Malaysia are equally diverse. For example, when I was a boy, I spoke Hakka dialect at home and Mandarin, Bahasa Malaysia, and a little English at school.⁴ Given this cultural diversity, Malaysia is still coated with a tint of British colonial influence. In Malaysia, you still find that generations after generations of people are bound by traditional values. We value family ties and familial roots; we seek harmony with the universe and emphasise spiritual cultivation.

Religion has a prominent and strong impact on the traditions and values of Asian people; most of the people living in Asia find religion and language to be really important to them. The diversity of dress codes is conspicuous, and festivals are tremendously influenced by local religions. People in Malaysia are still bound to their roots, and most of all, they cherish their traditions. Malaysia has a socially mixed context that involves various religions and ethnicities. When I was growing up in a small Chinese village surrounded by Malay and Indian villages, my ears picked up all kinds of sounds, including the ritual and ceremonial music at local Hindu temples, the Buddhist chants at a Buddhist centre that I attended with my parents, the Cantonese and Hokkien opera performances held in the Chinese local feasts and ceremonies at local Taoist temples, the recitation of Quranic verses five times a day from a mosque beside our village, the Malay wedding performances at a field outside the neighbourhood, and of course, mainstream American and local pop music that permeated almost every shopping mall and radio station in Malaysia. I was lucky to be immersed in all these cultures. All multicultural practices of each ethnic group really fascinated me!

My musical education in the Malaysian Institute of Arts introduced me to the cosmopolitan city life of Kuala Lumpur, and my formative studies in China with Prof. Yu Yan Rao and Prof. Da Long Zhang at the Xian Conservatory brought me full circle with my Chinese heritage. During my studies in China, I was exposed to the music, poetry, literature, art, and calligraphy from the Tang dynasty (A.D. 689–740). Till today, my music reflects these influences in terms of my approach to ensemble instrumentation, instrumental setup, musical form, and unique tuning temperaments.

Upon completion of my Bachelor of Arts in Xian, Prof. Rao encouraged me to pursue my final studies at the Royal Conservatory of Brussels, where I developed the skills for my compositional style today. In 2001, I received my Master of Composition with the Highest Honours from the aforementioned educational institution.

³ Bumiputera (or Bumiputra) literally means “son(s) of the soil.” This modern Malaysian word was first used in the 1920s and 1930s in the Malay Peninsula. Bumiputera refers to the indigenous people and native communities of Malaysia (Ismail, 2004, p. 287).

⁴ I attended a government Chinese primary and private independent Chinese high school.

Out of these early experiences in Malaysia and from later music studies in Malaysia, China, and Belgium, I have developed a musical language that embraces rich instrumental colours. Furthermore, I never stop searching for new instrumental possibilities as well as the past traditions of my own Chinese multicultural Malaysian heritage. For example, traces of Gamelan music can be found in my *Monodrama* (2004) for oboe, Western ensemble, and live electronics; hints of Chinese funeral rituals can be perceived in the ensemble work *Wu Yan* (2003, rev.2014) for 6 percussionists; and elements of calligraphy are employed in the poetics of the *Shui.Mo* (2007) concerto for four Chinese instruments and symphony orchestra. The quest for my Chinese roots is also reflected in my exploration of the sonic possibilities of traditional Chinese instruments. In my compositions, I have experimented with various traditional Chinese instruments (mainly the 37-reed soprano sheng, gu zheng, and pipa) and Chinese instrument ensembles to investigate their sonic characteristics and interaction with Western instruments and sounds. The musical elements, instrumental setups, and playing techniques will be elaborated in the following chapters.

2. East-West intercultural exchange

After studying and living in Brussels for nine years and travelling around the globe to attend numerous art and music events, I have developed a strong interest in Western modernism, its traditions of analysis of the self and identity, and the re-examination of every aspect of existence.

Appreciating the virtuosic nature of Western instruments and the unique aesthetics of Asian traditional music, I composed solely for Western instrumentation to study all its potentials during the period of 1994–2004. My early work *Lui-Xu-Fei* (Flying willow catkins; 2001) is an illustration of how I tried to explore the oboe and cello's articulatory and vibratory characteristics. Only later, in *Metamorphosis VI-Wind prayer* (2005), did I bring together instrumental traditions that combine the Chinese pipa's characteristic playing technique of full tremolo “*gun*” (滾) and “*lun*” (輪),⁵ the complex timbres produced by oboe multiphonics, the traditional techniques of tone bending “*Tui*” (推) and “*La*” (拉)⁶ in the pipa and “*Rou Yin*” (按音)⁷ in the gu zheng, the different types of glissandi created on piano strings, pedal glissandi in the harp, and the skin pressure glissandi on the bass drum.

I strongly believe in Prof. Wen Chung Chou's idea of “confluence” and “re-merger” of legacies:

⁵ “*Gun*”: Fast paced and continuous plucking of tan and tiao to produce a well rounded sound. This symbol can be written below a note, instead of above it. “*Lun*” The forefinger, middle finger, ring finger and last finger flick outwards from right to left in order, while the thumb picks the string from left to right. This is a basic cycle of a *lun* and the perspective of right and left is from a performer's viewpoint (Wong, 2005, p. 28).

⁶ “*Tui*”: Left finger pressing the string pushes inwards along a fret to raise the sound that the string produces (Wong, 2005, p. 29).

“*La*”: Left finger pressing the string pulls outwards along a fret to raise the sound that the string produces (Wong, 2005, p. 29).

⁷ Every string of gu zheng can produce a note up to a third higher from the string's tuned note when the string is depressed on the left side of the bridge (Wong, 2005, p. 79).

What I have been speaking of is not a “new” culture, but a “merger” or “re-merger” of legacies, not cultural “influence” but a “confluence.” In contrast to “borrowing” by the West from the East in the past, or the East from the West today, “merger” means coming together, sharing each other’s heritage, complementing and revitalizing legacies (Chou, 2001).

Like Chou, my music aims to enhance the understanding of various cultures and to raise the awareness of preserving each culture's uniqueness. I am deeply interested in how a new East–West aesthetics in multi-layered cultural and ethnic heritages can influence music. This inquiry has since played a crucial part in my compositional approaches.

3. Oral traditions

I have always been fascinated by the fact that Asian music is traditionally based on oral transmission. In most of my compositions, the interplay and interchange of roles between instruments through their alternations of similar passages in an improvisational style are inspired by the oral traditions in the teacher-student mentorship relationship in the study of music. For example, this mentorship tradition can be found in Chinese operatic singing (e.g., Peking opera [京劇],⁸ Kun Qu [昆曲],⁹ Nan Yin [南音],¹⁰ and folk songs [民歌]), Chinese instrumental music (e.g., *quqin* [古琴]), Malaysian or Indonesian Gamelan and singing (e.g., folk songs and ritualistic and ceremonial singing), Korean Pansori, folk songs (*minyo*), court music, *sanjo gayageum*, Japanese Gagaku and Noh, Thailand’s *pi phat*,¹¹ and many other traditional music genres in Southeast Asia.

In addition, the tradition of teacher-student mentorship in the study of music creates a unique personal character in most of the Asian music repertoires. Through this oral transmission, students learning from the same teacher would develop their personal touches in terms of emotions, expressions, and life experience. Concurrently, these personal touches are infused into traditional melodies while the students develop individual music structures and characteristics during music performance. Hence, the interpretation of the same melody or song varies between individuals but is grounded in the oral transmission traditions from the master. During this process, traditional

⁸ Peking opera consists of dialogue sections and singing with orchestral accompaniment, and the two dominating styles, *erh-huang* [二簧] and *hsi-pi* [西皮], can be varied endlessly in melody to carry different emotional significance. *Er-huang* generally occurs in more serious sections, whereas *hsi-pi* is livelier and merrier (“China-Drama-Peking opera,” p. 257).

⁹ *Kun Qu* is notable in being based on written librettos and in having a system of notation for writing down its music. Its tunes are delicate and slow-moving, with a regular 4/4 rhythm; a single word may be sung over an extended melody. The principal instruments are the *ti-tzu* and *hsiao* (Chinese transverse and end-blown flutes; “China-Drama-Peking opera,” p. 254).

¹⁰ *Nanyin*, one of China's most ancient music, is an ensemble consisting of singing and instrument playing. *Nanyin* vocal pieces use the Quanzhou dialect. *Pipa* (four-string lute), *Sanxian* (three-string lute), and *Paiban* (wooden clappers) are the main instruments (Gong, n.d.).

¹¹ “The music of Thailand’s royal courts owes much to Angkor musical traditions. The Thai ensemble called *pi phat* is clearly related to its Cambodian cousin; it includes a double-reed wind instrument (*pi*), *xylophones* (*ranat*), *gong chimes* (*khawng*), *cymbals* (*ching*), and *drums* (*taphon*)” (Spiller, 2004, p. 32).

ornamentation in music is passed down from generation to generation with every student's creative participation. Consequently, the ornamentation becomes a living configuration where the shape of the music is constantly changed by different generations. I refer to the concomitant inheritance and evolution of music traditions in this process as "living ornamentation" and will further illustrate this concept in Chapter III.

4. Vocalisation

Vocalisation is a crucial element in my compositions. It is one of the key Southeast Asian features that I intend to showcase in my compositions through the vocal effects and singing by musicians. Therefore, I asked instrumentalists in most of my compositions to vocalise. I asked them to sing in an untrained voice without Western *bel canto* types of vibrato. Such singing is what I think represents the voice of the villagers in many Asian countries, where traditional performers and musicians are musically untrained villagers who work in farms and perform ceremonies in temples during their leisure time. This form of raw vocalisation marks my current artistic direction and draws me closer to the spirit of my Asian roots.

In addition, the use of vocalisation is closely associated with my life experience and the Hakka background of my family. My maternal grandfather was a legendary Hakka mountain song singer and was also known as the storyteller Master Sak. He worked as a Chinese traditional medical doctor in his daily life and performed for the villagers during his leisure time or when local festivals were held. He was not professionally trained in any "music school" but learnt singing Hakka mountains songs and storytelling from his master, colleagues, or other folks. Furthermore, my parents taught me the value of Hakka culture and heritages since I was young. They spent time telling me the stories of how my grandparents migrated to Southeast Asia (Nan Yang), struggled with their hard life here in order to raise them, and kept teaching them the value of my Hakka spirit.

My maternal grandfather's singing and storytelling and the Hakka spirit I learnt from my parents have inspired me to compose a concerto that integrates vocalisation and my Hakka heritage. In 2013, I wrote a 29-minute large scale concerto *Hak.Qin* (客。情)¹² for sanxian, gu zheng, voice, and Chinese orchestra with pre-recorded audio. The work was commissioned by the Singapore Chinese Orchestra and especially written for my music advocate, the gu zheng / sanxian / voice virtuoso Ms. Feng Xia Xu.¹³ This work was composed in memory of my beloved late maternal grandfather, Hakka storyteller/mountain song singer maestro Sak. As a Hakka living in Southeast Asia, I feel proud when listening to the legendary stories of Master Sak related by my parents. In those stories, I was particularly moved by a Hakka saying that our ancestors told their loved ones

¹² The limited length of this section does not allow further analyses of this composition. If readers are interested in this piece, please contact the composer or watch the youtube video clip of *Hak.Qin* at <https://youtu.be/kQin-VhnVUU>.

¹³ I will further discuss my collaboration with Ms. Feng Xia Xu in Appendix A.

after they left their hometown in China and sailed to the Nan Yang (Southeast Asia). Not knowing when they would go back to their hometown, the Hakka ancestors said that when:

「等到滑哥（泥鰍）生鱗, 馬生角.. 涯就轉來！」 (In Hakka)
“Loach grow scales and the horse grow horn, then I will be back home!”

In this composition, I intended to create a sonic landscape of “mountains” for the musicians. The sanxian/gu zheng soloist Feng Xia Xu performed and then walked from one position to another to symbolise the Hakka immigrants who sailed from their hometown to Nan Yan to look for a new life (Fig. I-1). In the very beginning of the piece, the soloist played her sanxian,¹⁴ sung the opening calling signal of Hakka mountain songs, and then started reciting the Hakka phrase I mentioned above to tell the loved ones that they will never return to their hometown.

¹⁴ In traditional storytelling performances in China, artists often accompany themselves with a sanxian (a three-stringed plucked instrument) while singing and telling stories in alternation.

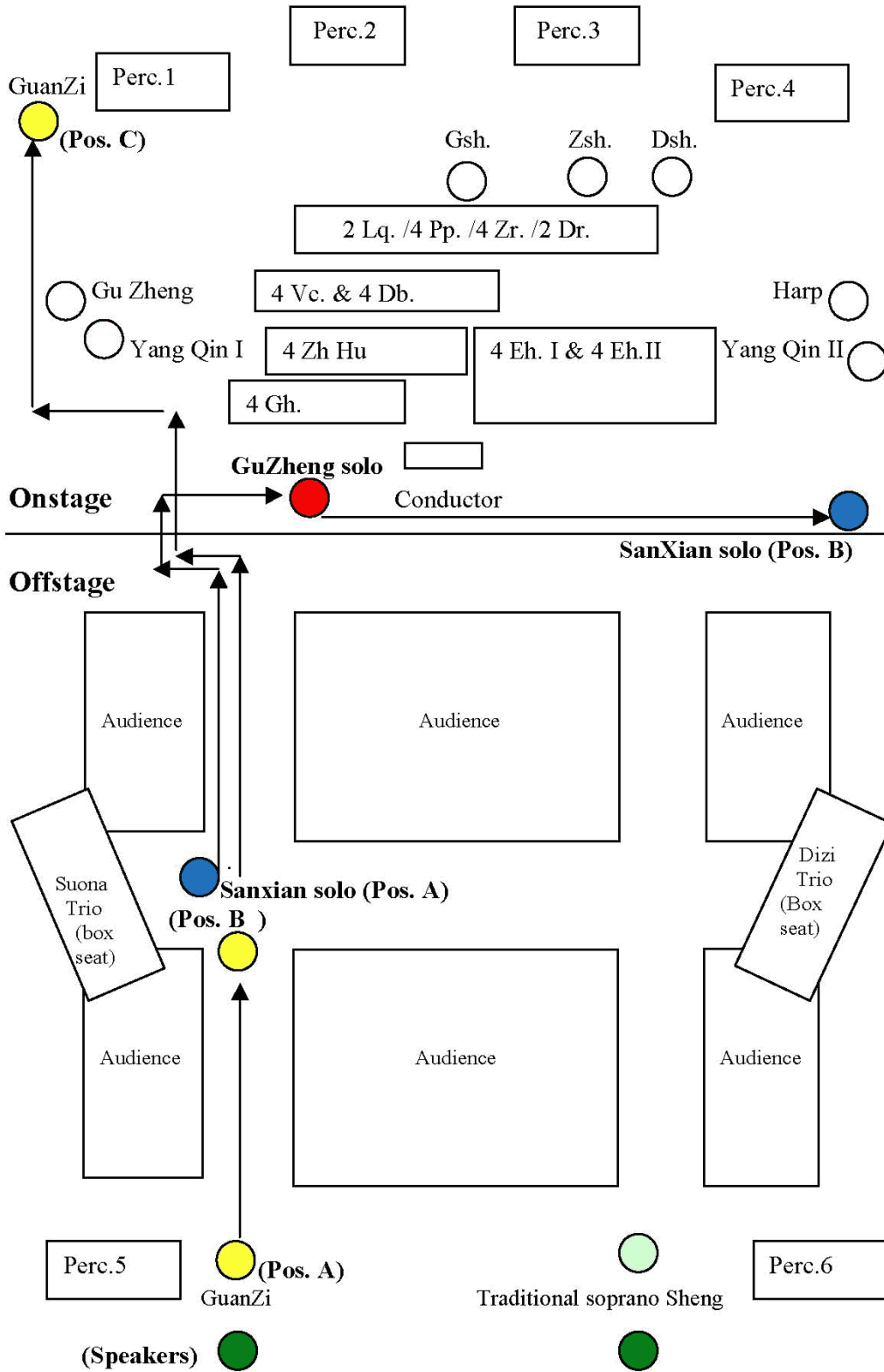

Figure I-1: Instrumental setup of *Hak.Qin*

See the score example for this opening passage:

The image shows a musical score for the opening passage of *Hak.Qin* (2013). It consists of two staves. The top staff is for the vocal line (人聲) and the bottom staff is for the guitar line (Strumming). The score includes various dynamics such as *f*, *mp*, and *sfz*, and performance markings like *wide vibs.* and *Sub.*. The score is in staff notation with various notes and rests.

Figure 1-2: Bars 1–7, soloist part of *Hak.Qin* (2013)

5. Developing a personal style from the formal elements of Asian music

Most Asian music genres exhibit unique temporal characteristics. For example, different durations of silence can be found between notes in various types of Asian music (e.g., Chinese guqin, Japanese Gagaku and Noh, and Gamelan).

In his essay “My Perception of time in Traditional Japanese Music,” composer Takemitsu argues that:

Nature is conceived in term of the seasons, and this has given rise to a unique temporal sense, which has been further fostered by the influence of Zen and Buddhists teachings. This special temporal sense is strongly reflected in the time structures of the traditional music of Japan (Takemitsu, 1987, p. 11).

Brevity and empty space in music is crucial to magnifying the intensity of the expression of an entire composition. Those silent moments create a tension that heightens the audience’s appreciation of music. The temporal structure of Asian music provides me with a means of circumventing Western compositional procedures. Jōji Yuasa, another Japanese composer, remarks on the temporal structure in the traditional Japanese performance art form in music and dance:

Temporal structures are conceptual in nature. For example, linear time and circular time are conceptually different. The former is found in Western music in general and the latter is found in the Japanese traditional music affiliated with Buddhism. In circular time there is no distinction between past, present, and future. These are clearly delineated in linear time. . . . One phenomenal difference exists between the Japanese traditional structure of time and that of Western time: traditional Japanese time is not based on physical movement; rather, it is based on respiratory continuity. It is thus, by comparison, far more spiritual than physical (Yuasa, 1989, p. 178).

After many fieldwork trips to different cities in China, Korea, Indonesia, Thailand, the Philippines, and my home country Malaysia, a range of ethnic ritualistic and storytelling elements have exerted a strong influence on the inner structure of my compositions. Of particular interest to me is the way in which ritualistic elements, temporality of repetitive structures, and the use of silence and pacing create a trance-like state for performer and audience.

Composer José Meceda, pioneer of modern Philippine music, comments on his large-scale fieldwork studies in Southeast Asia:

The music of Southeast Asia fills time along notions of continuity, infinity and indefiniteness in a non-secular metaphysical world, and hierarchy in a secular world. The musical techniques used in musical forms prefer melodic ambiguity, repetition and diffusion to an identification and isolation of things as these are brought about by a system of logic known as causality (Maceda, 2005, pp. 150–151).

6. Collaboration

The people whom I am writing for form a crucial part of the compositional process, as the musicians who are premiering the piece always inspire me. The inspiration stems not only from how they perform as musicians but also from their personalities. Working with great Chinese and Western musicians and observing diverse disciplines has been a source of great stimulation to me.

In 2005, I was fortunate to meet three Chinese virtuosos in Amsterdam, i.e. Wei Wu, Feng Xia Xu, and Xiao Fen Min to work on *Metamorphosis VI-Wind Prayer* (2005), my first composition that employed both Eastern and Western instruments. Since then, I have explored the sonic possibilities of traditional Chinese instruments in my compositions and worked closely with Mr. Wei Wu, composing many pieces for him and the Dragon Ensemble (Berlin). I was also inspired by the ink paintings of my German friend Mrs. Helena Belzer, as well as Belgian painter Sigrid Tanghe's visual art works and her live painting performances on stage.

In Chapter II, the influences of Asian cultures and heritage on my compositional practices are illustrated through examples from my portfolio. Next, I discuss how I have developed a personal compositional style informed by the structural and performative elements from various Asian traditions in Chapter III.¹⁵ In this chapter, I concentrate on several major aspects of my compositional style in my works and elaborate on the key concepts of symmetrical structure, sonic mobility and spatialisation, interplay and interchanging of roles, and living ornamentation in *Yuan-Liu* (2009) to demonstrate how they help create heterophonic texture in my compositions. Finally, I conclude this thesis by highlighting the key points I raise in the previous chapters and expressing my expectations for continuously composing works based on cultural heritages and confluence.

¹⁵ I developed Chapter III from some of the crude ideas in a lecture I gave at the Goethe Institute's "Young Composers in Southeast Asia Competition & Festival 2011" on 5th October 2011, at Universitas Pendidikan Indonesia, Bandung (Indonesia).

Chapter II. Influences of Chinese cultures and heritage on my composition

The range of influences from Southeast Asia will be discussed in Chapter III and the lecture paper in Appendix A. In this chapter, I will focus specifically on the importance of Chinese philosophical and poetic thinking in relation to my compositions. Recurring themes include the symbolic use of Chinese instruments to represent the legacy of Eastern traditions and the spatialised arrangement of musical instruments in order to create a mobile world of sounding energies.

1. *Shui.Mo* 水。墨 (2007)

Shui.Mo (Water.Ink) is written for four Chinese instruments (er hu, pipa, gu zheng, and sheng) and Western orchestra. I have been moulding my compositional approaches according to the inspiration of Chinese art forms such as calligraphy, painting, and poetry. Appropriately named after the two fundamental elements that are combined to produce calligraphy, *Shui.Mo* literally means water and ink in Chinese; however, when the two Chinese characters are joined together, the resultant phrase denotes “monochrome ink painting.” I integrated the Chinese instrumental ensemble with a Western orchestra by conceptualising them as water and ink in calligraphy.

Shui.Mo was inspired by the calligraphy of Prof. Wen Chung Chou. The work consists of two movements that are played without a break. The first movement “Shui Wen” means ripples of water and is dedicated to my mentor Prof. Wen Chung Chou. I quoted one of the characters of his name “Wen” in the title of this movement. The second movement “Mo Yun” means the charm of the ink and is written in memory of Korean composer Isang Yun. I quoted his family name “YUN” in the title of the second movement.



Figure II-1: Calligraphy specially written for *Shui.Mo* by Prof. Wen Chung Chou

The soloists of Dragon Ensemble, namely Zhen Fang Zhang (er hu), Ya Dong (pipa), Feng Xia Xu (gu zheng), and Wei Wu (sheng), had been in my mind when I wrote for their parts, as these musicians are at the heart of the inspiration for the innovative and creative approaches in *Shui.Mo*. I employed traditional performing techniques—such as different types of clusters on the traditional 37-reed soprano sheng, extremely wide vibrato “Ya-Rou” (压揉) on the er hu, the characteristic strumming and tremolo on the pipa, and the different bowing techniques of the gu zheng—and merged these together with unconventional extended techniques creating a broad palette of colour to paint my musical canvas in this concerto.



Figure II-2: From left to right: Kee Yong Chong (composer) and soloists of Dragon Ensemble, Feng Xia Xu (gu zheng), Ya Dong (pipa), Zhen Fang Zhang (er hu) and Wei Wu (traditional 37-reed soprano sheng) (Photo credited by Sigrid Tanghe)

Since 2005, I have adopted the ideas of mobility and spatialisation for the soloists and orchestral musicians in the performance of most of my compositions. In *Shui.Mo*, the orchestra is divided into various groups and distributed in a three-dimensional space around the audience. The er hu, pipa, and gu zheng soloists are seated at the centre-front of the stage, and the sheng soloist plays in four positions, starting from the left side of the stage and gradually walking toward the right as the composition progresses.

The experience of growing up in a rustic environment inspired me to recreate a three-dimensional listening experience that differs from those provided at conventional concerts. The instrumental setup of *Shui.Mo* is as follows:

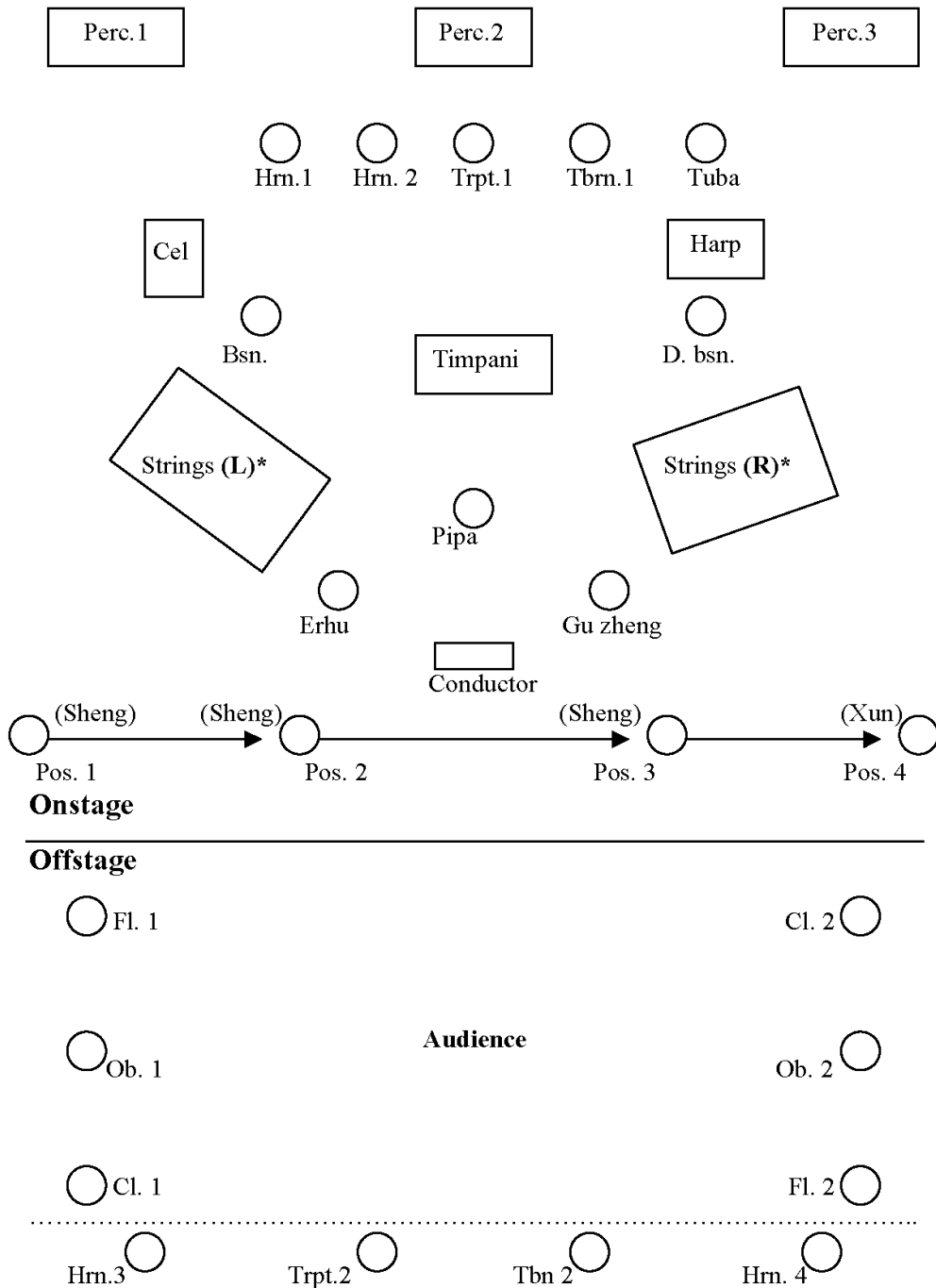

Figure II-3: Instrumental setup of *Shui.Mo*

The soloists in this composition are required to vocalise with glissandi (sliding) in or within perfect fourths to imitate the hooraying or singing of Hakka mountain songs. In addition, the gu zheng soloist is allowed to sing with his/her own ornaments or even improvise according to the given melodic contour. Consequently, the perfect fourth and the narrow-range glissandi together form a strangely comforting cry that resembles the wordless singing in Hakka mountain songs. This sound and the setting remind me of the deep forests in Malaysia or the mountains in Southern China where my grandparents came from and where the sounds of human inhabitants counterpoint with the sound of nature on a daily basis.

The following score extract is from the soloist part of *Shui.Mo*:

The image shows a musical score extract for the soloist part of *Shui.Mo*, consisting of four staves: Erhu, Pipa, Guzheng (G.Z.), and Sheng. The score is divided into two systems, with the first system ending at bar 54 and the second starting at bar 55. The tempo is marked as *poco a poco string, e intenso* and *Tempo rubato* with a metronome marking of $\text{♩} = c.42$. The score includes various performance instructions such as *14 tone vibr.*, *14 tone bending*, *ring (diamond-shape note head)*, *low pressure noise*, *inc. (L.H)*, *exc.*, *bowing of lhb*, *increasing pressure noise*, *put down the bow*, *damp the strings firmly*, *not fast*, and *from here walk slowly to position II*. Dynamics range from *pp* to *ff*. The score also includes a *scempre* marking and a *molto* marking.

Figure II-4: Bars 48–61, Chinese instrument ensemble part of *Shui.Mo*

The first movement closes with an improvised aleatoric section for all four soloists and ends with the distant echoes of high harmonics trills played by the two offstage flutes. The ending section (bars 141–148) of the first movement merges into the second movement through a bridge led by the sheng.

The image shows a page of a musical score for the first movement of *Shui Mo*, covering bars 141 to 148. The score is for a full orchestra and includes various percussion instruments, woodwinds, strings, and brass. It features tempo changes from "Molto calmo e lontano" to "Tempo rubato" and back to "Senza misura". The score is densely annotated with performance instructions such as "water gong (M)", "hand drum (L)", "Japanese temple bell (S)", and "Cadenza improvisation". Dynamics range from *ppp* to *f*. The score ends with a "rit." and "Senza misura" marking.

Figure II-5: Bars 141–148, ending section of the first movement of *Shui Mo*

In the second movement, the soloists stir up the orchestra, whose onstage and offstage instruments are one by one animated to converse excitedly with one another. Later, the brass and percussion join in to make powerful declamations

yet halt at their climax to allow the four soloists to make their statements in an exchange of cadenzas.

Figure II-6: Bars 30-36, build up section of the second movement of *Shui.Mo*. The score includes parts for Percussion 1-3, Horns 1-2, Trumpet, Trombone, Cymbal, Bass Drum, Snare Drum, Timpani, Violins 1-2, Violas 1-2, Cellos, Double Basses, Electric and Acoustic Guitars, and Basses. The score features complex rhythmic patterns, dynamic markings (ppp, mp, mf, f), and tempo markings (Senza tempo, A tempo). The percussion parts are particularly prominent, with intricate patterns and dynamic shifts. The string parts provide a harmonic and rhythmic foundation, with some parts featuring complex rhythmic figures. The overall texture is dense and dynamic, building up towards the end of the section.

Figure II-6: Bars 30-36, build up section of the second movement of *Shui.Mo*

After the climax, the second section builds towards a recapitulation of the cadenza from the first movement, which has the gu zheng player, again, performing the Hakka mountain song passage. The piece ends with the haunting calls of the Chinese ancient instrument xun (埙), a Chinese ocarina played by the sheng player. In this passage of haunting calls, the xun player follows the notated rhythm but is free to play the notated melody in any key. This is a “half-open form” of improvisation for the xun player. My intention in this ending section is to create a flow with clear rhythmic gestures while leaving the melodic shapes and articulations to the player’s decision and interpretation.

The image shows a musical score for the ending section of *Shui.Mo*. It consists of four staves: E.h. (Erhu), Pp. (Pipa), G.z. (Gu Zheng), and Sh. (Xun). The score is divided into two sections, G and H. Section G is marked 'Molto calmo e lontano' with a tempo of ca. 9" and 'Senza misura'. Section H is marked 'Tempo rubato' with a tempo of ca. 42 and 'Senza misura'. The score includes various dynamic markings (ppp, p, mp, f, mf) and performance instructions such as 'molto rit.', 'solistic & rubato', and 'Completely silent'. There are also notes about improvisation and rhythmic suggestions for the Xun player.

Figure II-7: Bars 100–109 in the second movement, sheng soloist playing the xun in the ending section of *Shui.Mo*

2. *Bie Ge* 別歌 (2012)

In 2012, I was invited to compose *Bie Ge* (Song of Farewell) for the concert “Percussion and Vocal Music,” jointly performed by the Forum Music Ensemble and the Taipei Chamber Singers on 19th November 2012 at Taipei Zhong Shan concert hall. *Bie Ge* is my first composition for vocal choir, which describes the moment when helpless and besieged soldiers, who are facing their enemies, are reminded of their families. This work portrays the struggle between life and death when facing the urge to surrender while feeling devastated with mixed emotions. This composition commemorates the countless unknown soldiers who died for peace in history.

Lyrics of *Bie Ge*¹

大風起兮	A great wind came forth,
力拔山兮	My strengths plucked up the hills.
生兮，死兮	To live, or to die?
路窮絕兮，老母已死兮	The road ended here, and my mother was long gone.
士眾滅兮，少壯幾時兮	The soldiers perished, while they were still young and vigorous.
時不利兮，草木黃落兮	The times were against me, and the grass and trees withered.
蕭鼓鳴兮	War drums sounded,
降兮，滅兮	To surrender, or to perish?
老母已死兮	My mother was long gone, and
欲報恩將安歸！	How I wish I could return home and repay her with my gratitude!

Bie Ge involves six percussionists: four on the stage with two on either side of the audience. The 38 choir members are divided into four groups around the audience, and their lyrics are composed of (A) words rearranged from the famous *Songs of Chu* and (B) functional words with no particular order and meaning. In addition, all choir members play xuns of different sizes and rub bamboo leaves being percussion instruments.

¹ The lyrics of *Bie Ge* are mainly extracted and adapted from two famous songs composed in the late Chu and early Han dynasties: “The Hegemon’s Lament” by XIANG Yu (232–202 B.C.) and “Song of the Great Wind” by LIU Bang (256–195 B.C.). The lyrics were translated into English by Kelly Poyu Chen with a reference to Minford and Lau (2002).

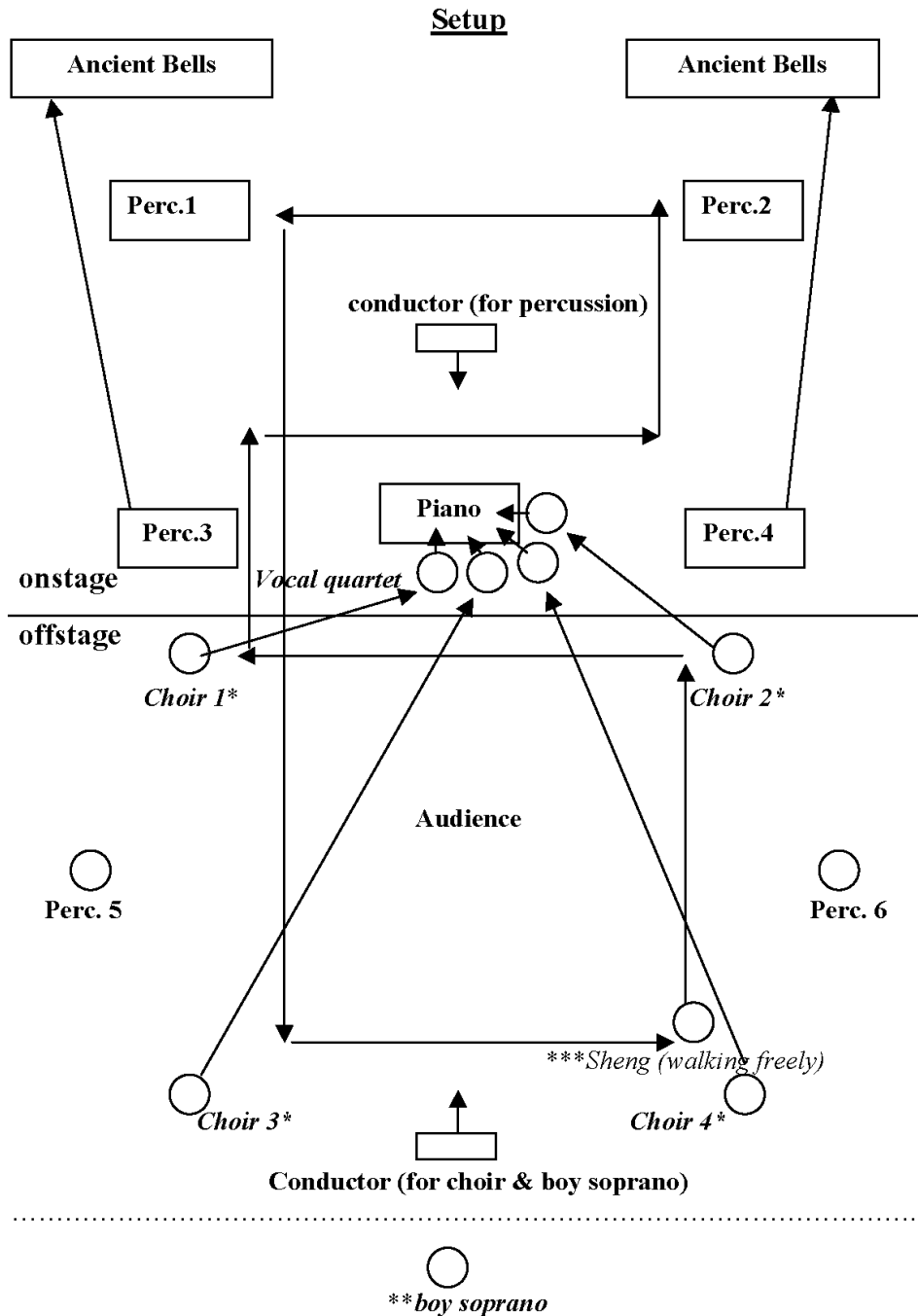

- * Vocal quartet (suggestion: soprano from choir 1; alto from choir 2; tenor from choir 3 and bass from choir 4) from rehearsal mark K walking slowly to the piano position and sing into the piano's strings. (onstage)
- ** Offstage boy soprano positioned in balcony of the back of audience.
- *** Sheng player is walking freely from offstage to onstage during the performance. The player can follow his own route in the performance.

Figure II-8: Instrumental setup of *Bie Ge*

The sheng plays a significant part in the piece symbolically recalling the forces of ghostly figures as well as the energetic states of the earth. The instrument expresses a prolonged breath depicting the lost and lonely ghosts of historic battles who wander on and off the stage freely. In near complete darkness, *Bie Ge* begins with a single prolonged note from the sheng which unfolds the awakening



Figure II-10: Traditional 24-reed soprano sheng player Mr. Lung-Yi Huang wandering on and off the stage freely in *Bie Ge* (Photo credited by Ding Hao Lin © 林鼎皓)

The audience, percussion, vocal sounds, and sheng are seemingly unrelated yet closely interconnected. In the middle of the composition, the repeated percussion ostinato patterns reflect the vicissitude in history. The sheng performer keeps wandering about the auditorium aimlessly. When he approaches the percussionists or the singers, their sounds clash together and burst into resonance relating the relentlessness, panic, helplessness, and losses of wars.

In the middle section, the percussionists begin the vocalisation of the verse section while the choral singers play xuns of different sizes, producing chanting-like sounds. The exchange of roles between the percussionists and the choral singers and the tolerance for each other's dilettante, untrained playing bring unity in disorder. The xun is an instrument used and played by the commoners of the Chu dynasty. I employed this instrument to represent the commoners' songs for calling their loved ones to surrender and return home.

** J [from here 4 singers (S/A/T/B) walk towards the piano position!(onstage)] → (please note that when you reach the piano position and continue playing the xun toward the piano's strings!)

Più espressivo e intenso

The musical score consists of four systems of staves for Soprano (S), Alto (A), Tenor (T), and Bass (B). Each system includes a vocal line and an 'air sound' diagram. The vocal lines are marked with 'xun div.' and 'Normal' air sound. The 'air sound' diagrams show a wavy line representing the sound, with 'wide vibr.' and 'pp' markings. Performance instructions include 'continue and in home-sick manner' and 'always molto rubato & dynamics free! (improvising on given melody contour & rhythmic suggestion)'. Dynamics range from ppp to mp. The score also includes a 'poco a poco cresc.' marking and a 'molto espr.' marking.

Figure II-11: Bars 91–95, choral singers play xuns of different sizes, producing imperfect chanting sounds in *Bie Ge*



Figure II-12: All the offstage choral members playing xuns of different sizes (Photo credited by Ding Hao Lin © 林鼎皓)

In the end, the sheng performer slowly walks to the centre of the stage and produces several forceful high-pitched “Mo Yin” (抹音)² gliding sounds. The swelling “Mu Yin” embodies a soul’s internal struggle and screams. Then a boy soprano sings the folk song-inspired melodies amidst the audience; one of the four choral groups gradually moves onto the stage and surrounds the piano, expressing the yearning for home and family.

The musical score for Figure II-13, bars 106-110, is a complex orchestration. It begins with a tempo marking of *Tempo rubato* and a metronome marking of approximately 35-40. The score includes parts for Percussion 1-6, Chinese singing bowls, and a vocal quartet (Soprano, Alto, Tenor, Bass). The vocal quartet part includes lyrics in Chinese characters: "其 安 靜", "老 母 已 死", "歌 聲 悲 怨", "老 母 已 死 兮". The score features various dynamics such as *ppp*, *p*, *f*, and *pp*, along with performance instructions like "rubbing the edge of the singing bowl and walk to bian zhong (ancient bells) position!" and "sing into piano! (with the damper pedal depressed)". The score also includes a section for the vocal quartet with the instruction "Tempo rubato (offstage) should sing in most simple and remote way!".

Figure II-13: Bars 106–110, a boy soprano sings the folk song-inspired melodies among the audience, and a vocal quartet moves onto the stage and surround the piano, expressing the yearning for home and family in *Bie Ge*

² The traditional soprano sheng’s bending pitches are only available in the register of a^2 – g^3 .



Figure II-14: Vocal quartet moving onto the stage and surrounding the piano, expressing the yearning for home and family in *Bie Ge* (Photo credited by Ding Hao Lin © 林鼎皓)

Finally, the light dims, the xun takes over the role of the sheng to convey the deepest and remotest calls. Two percussionists gradually walk towards two large and deep bianzhong (編鐘; i.e., Chinese court bells) to play a continued slow passage to recall the court music of the emperor. *Bie Ge* shows the influence of Asian aesthetics realised through the dense texture, the contrasts between the sound and silence, and the manipulation of musical space.

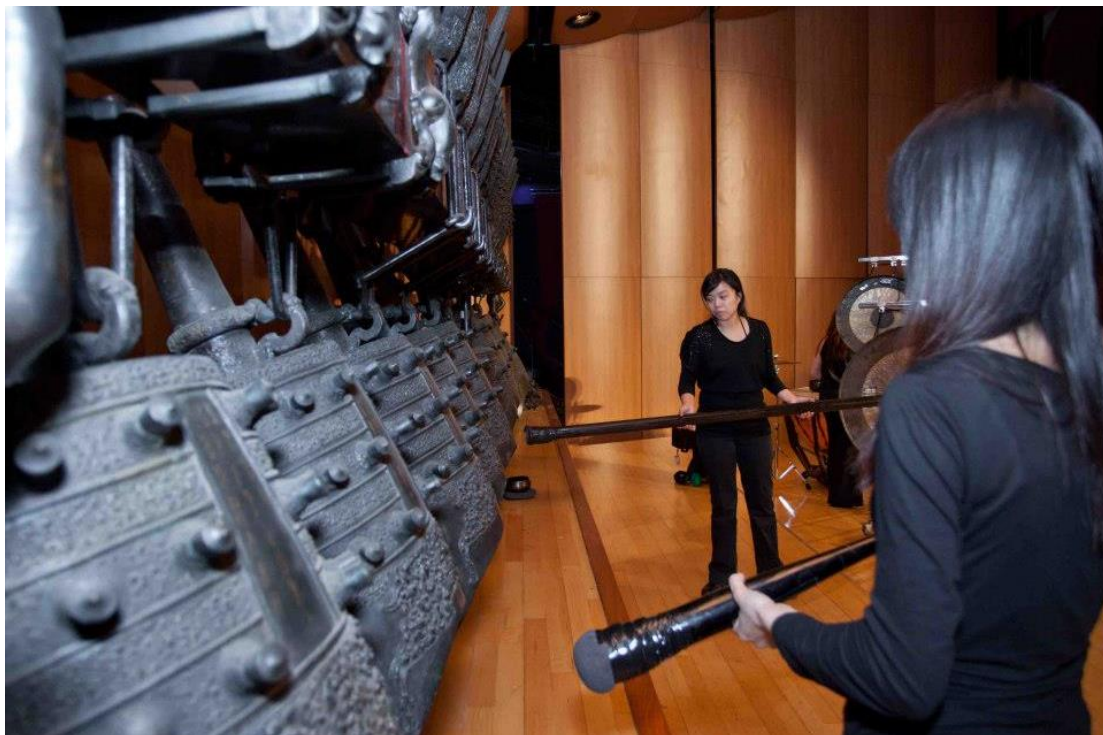

Figure II-15: Two percussionists playing two large and deep bianzhong in the ending section of *Bie Ge* (Photo credited by Ding Hao Lin © 林鼎皓)

The musical score for Figure II-16 spans from bar 116 to 110. It is organized into three measures labeled M, N, and O. Measure M is marked 'ca. 15° Senza misura', measure N is 'ca. 15° Senza misura', and measure O is 'Completely silent!'. The score includes parts for Percussion 1-6, Sheng, and Soprano. Percussion parts 3 and 4 are labeled 'bian zhong (ancient bell) [L]'. The Sheng part includes 'exhale' markings and 'blow (like wind blow softly, no accent)' instructions. The Soprano part is marked 'B.Sopra'. Dynamic markings include *pp* and *p*. A tempo marking of $\text{♩} = c.55$ is present. The score concludes with a long, sustained note in the Soprano part.

Figure II-16: Bars 116–110, ending passage showing the boy soprano, choir members (offstage), xun, and two large bianzhongs (onstage) in *Bie Ge*

After the world premiere performance, the choir conductor of this work, Ms. Yun-Hung Chen commented that:

In *Bie Ge*, Western percussion instruments are combined with sounds produced using materials found in daily life. . . . Performers scatter in the auditorium, walking aimlessly to produce surround sound, while audiences become performers without knowing it. . . . In this piece, the sheng is no longer just a sheng, and musical instruments are not just instruments. Likewise, vocal sound and the chorus are no longer contemporary aesthetic representation of discordant sound masses.³

3. *Xun Feng* 尋風 (2013)

Xun Feng (Seeking the wind) marks my first composition for traditional Chinese instruments (pipa, gu zheng, dizi/xiao, and 37-reed soprano sheng) and Chinese orchestra. This composition was commissioned by the “Chai Found Music Workshop” (Taipei, Taiwan) for their soloists and a student Chinese orchestra. It was premiered by Ms. Hui Kuan Lin (pipa), Ms. Jiuan-Reng Yeh (gu zheng), Mr. Lung-Yi Huang (sheng), and Mr. Chung-Hsien Wu (dizi/xiao), conducted by Mr. Chen Ming Huang at the Taiwan National Concert Hall on 16th March. The work was written in memory of my mentor Prof. Yu Yan Rao.

In ancient Chinese poetry, “Feng” (風; wind) represents folk songs as well as songs of the earth. You will find this word in the *Classic of Poetry*, the oldest extant collection of Chinese poetry that comprises 305 poems and songs dating from the 10th to 7th centuries B.C. As one of the six parts of the anthology, the “Airs of the States” (國風; Guo feng) are short lyrics written in simple language, usually ancient folk songs recording the voice of the common people. Common themes in these songs include love and courtship, longing for an absent lover, soldiers on campaign, farming and housework, and political satire and protest.

The instrumental setup is a crucial feature of *Xun Feng*, through which I aim to create a sonic landscape that bears resemblance to nature. It is like follows:

³ Personal communication with Yun-Hung Chen on 11th April 2015.

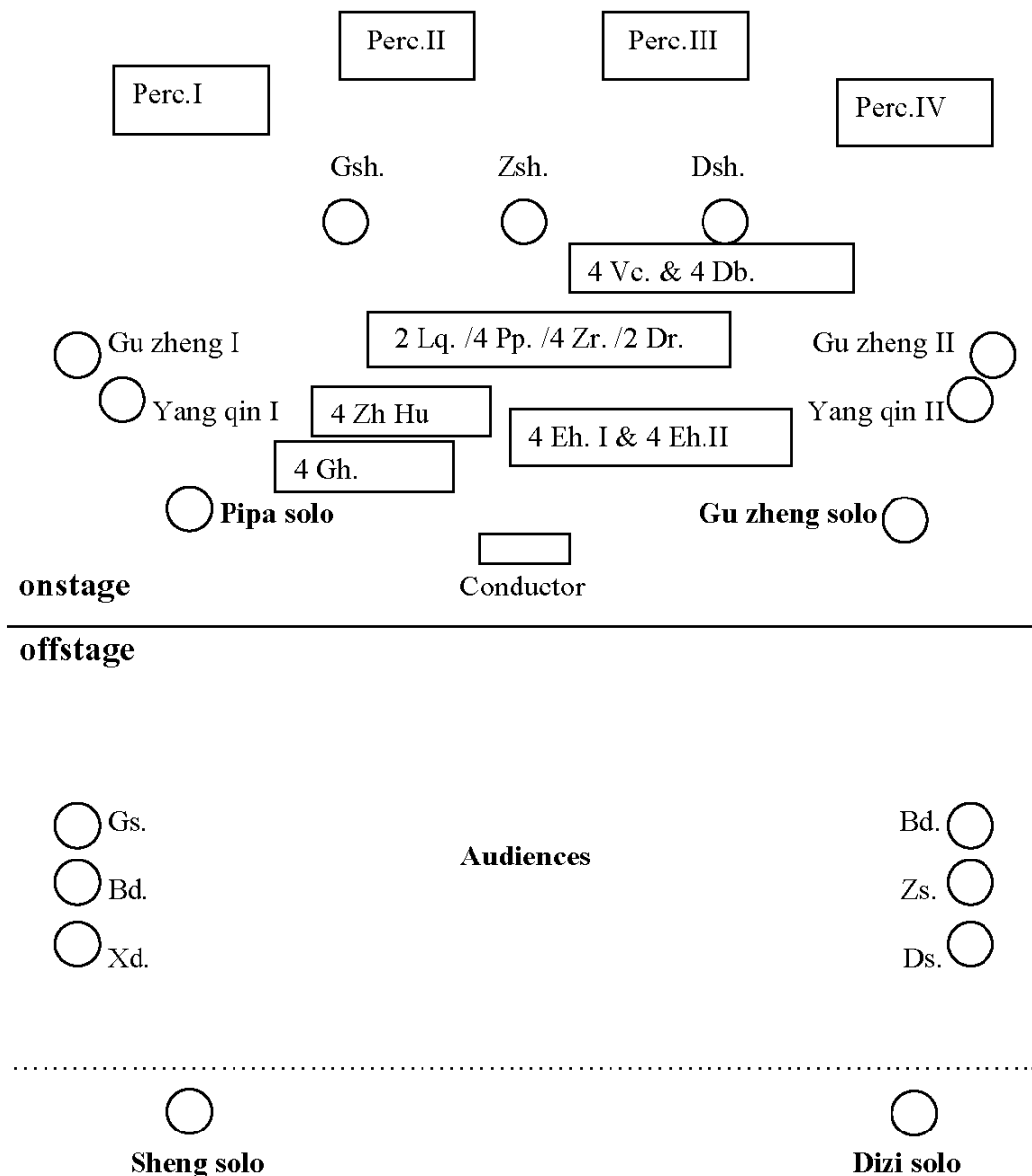

Figure II-17: Instrumental setup of *Xun Feng*

In 2012, I recorded Mrs. Chiung-Chih Liao singing a famous Taiwanese opera song “我身騎白馬” (Riding the white horse). I was moved by maestro Mrs. Liao, who is the most famous “Ku Dan” 苦旦 (sorrowful female character) singer in the Taiwanese opera scene. I transformed the recording into “old LP” quality audio and gave it as a ringtone to eight of the musicians (on stage and off stage) to playback during the end of the piece. The use of LP format in representing Mrs. Liao’s voice was to relive the experience of listening to Taiwanese opera LPs played by a gramophone in the past.

In this composition, I merged a large number of folksong fragments in abstract sound spaces, where each melodic fragment is woven between the soloists and the orchestra, producing colourful and spatial-auditory shifts. Most of the melodic fragments are derived either from Mrs. Liao’s songs or folk songs from

Xi'an and Shangbei in Northwest China where I met and studied with my mentor Prof. Yu Yan Rao.

I Senza misura J Completely silent

Figure II-18: Musical score for bars 162-167, featuring eight selected musicians (on stage and off stage) playing back the ringtone of Mrs. Liao's singing from Section G (beginning at bar 158) to the end of the piece. The score includes parts for Percussion 1-4, Gongs (Gh), Zhus (Zh), Dubs (Db), Yues (Yu I, II), Gongs (Gz I, II), Lqs (Lq), Pps (Pp), Zhus (Zr), Drs (Dr), Chus (Ch), Eb1, Eb2, Zhus (Zh), Vcs (Vc), Dbs (Db), Pips (Pip), Gzs (Gz), Gs, Qd, Xd, Bd, Zs, Ds, Sh. solo, and Dizi solo. The score includes dynamic markings (mp, p, f, fpp, fppp), performance instructions (e.g., "like distant echo", "sing (diamond-shape note head)", "continue circular rubbing the edge of the glass with finger"), and a "dynamic fluctuations irregularly" line. The piece concludes with a "Completely silent" section.

Figure II-18: Bars 162–167, eight selected musicians (on stage and off stage) play back the ringtone of Mrs. Liao's singing from Section G (beginning at bar 158) to the end of the piece

In *Xun Feng*, I integrate different tuning systems among the gu zheng soloist, pipa soloists, and Gu Zheng I & II in the orchestra to create a “shadowing” (exchanging “female” and “male” roles) pattern within the group of gu zheng players. In addition, the two soloists produce “shadowing” voices by singing the same melody with different intonations according to each instrument’s tuning, imitating an old voice (Lao Dan 老旦; pipa soloist)⁴ teaching a young voice (gu zheng soloist) how to learn the song phrase by phrase.

Gu Zheng solo tuning:



Gu Zheng-I tuning:



Gu Zheng-II tuning:



Pipa solo tuning:



Figure II-19: Different tunings for the gu zheng soloist, Gu Zheng I & II, and pipa soloist

In bars 1–6, all the three gu zheng performers play almost identical passages with bowing, a playing technique not traditionally used on the gu zheng, yet with different tuning and pitch arrangements.

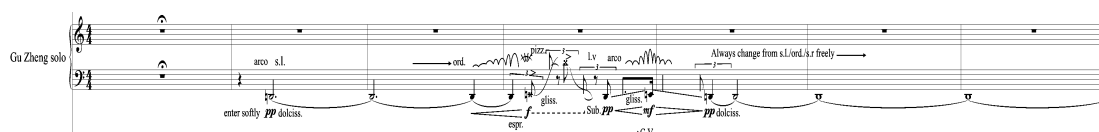

Figure II-20: Gu zheng solo (bars 1–6)



Figure II-21: Gu zheng I (bars 1–6)

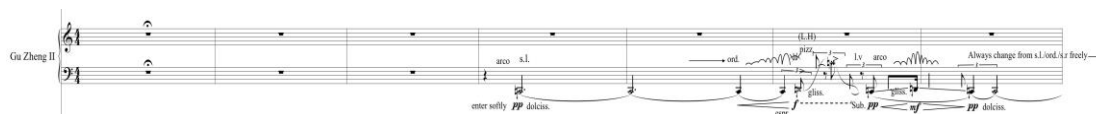

Figure II-22: Gu zheng II (bars 1–6)

⁴ The pipa soloist represents Lao Dan, a female character in Taiwanese opera, in this passage.

I highlight several features that are distinctly from North-West China either through fluid structures or from the constant presence of modal harmonies and, in particular, vocal effects and singing by the musicians. The pipa and gu zheng soloists sing like villagers going about their chores, humming, chanting, and shouting as though in a village play or performing some ritual – earthy, primal, yet comforting in its familiarity.

Figure II-23: Bars 14–19, pipa and gu zheng soloists’ vocalisation passage in *Xun Feng*

In *Xun Feng*, I avoid using percussion instruments with a well-tempered or definite pitch (such as keyboard percussion like Marimba, vibraphone, xylophone, etc.).

Figure II-24: Bars 1–7, percussion section in *Xun Feng*

In the percussion section, I employed the two low Javanese nipple gongs on the weak fourth beat every three bars in the Percussion 4 to form a gong circle which is reminiscent of the Javanese gamelan’s gong ageng⁵ circle structure:

Figure II-25: Bars 8–13, Percussion 4 playing 2 low gongs on the fourth beat of the bar

⁵ An extremely large hanging gong in Central Javanese gamelan or Balinese gong kebyar ensemble (Spiller, 2004, p. 277).

When the first section is repeated in the recapitulation passage, most of the instruments have the same material as during the initial section, whereas two of the offstage soloists (dizi and sheng) start to present new material, highlighting the idea of “living ornamentation” in Chinese traditional music.

This musical score covers bars 26 to 31. It features eight staves: Gs, Qd, Xd, Bd, Zs, Ds, Sh. solo, and Dizi solo. The Gs, Qd, Xd, Bd, Zs, and Ds staves contain similar melodic lines with dynamic markings of *p*, *f*, *pp*, and *mf*. The Sh. solo and Dizi solo staves introduce new material. The Sh. solo part includes a section labeled 'Sing & play (Sing the Sheng's edge note)'. The Dizi solo part includes a section labeled '1/4 tone bending'. Performance instructions include 'molto esp.' and dynamic markings like *pp*, *f*, *mf*, and *mp*.

Figure II-26: Bars 26–31, sheng and dizi section in *Xun Feng*

This musical score covers bars 133 to 138. It features the same eight staves as Figure II-26. The Gs, Qd, Xd, Bd, Zs, and Ds staves continue with similar melodic lines. The Sh. solo and Dizi solo staves present new material. The Sh. solo part includes a section labeled '1/4 note bending'. The Dizi solo part includes a section labeled '1/4 tone bending'. Performance instructions include 'molto esp.' and dynamic markings like *pp*, *f*, *mf*, and *mp*.

Figure II-27: Bars 133–138, sheng and dizi section in *Xun Feng*

4. *Yun Yong* 雲湧 (2011)



"Clouds" by German painter Helena Belzer
Use by permission © Helena Belzer

Figure II-28: Ink painting "Clouds" by German painter Mrs. *Helena Belzer*

On 12th February 2009, I was awarded a commission from the Serge Koussevitzky Music Foundation and the Momenta String Quartet (New York) to compose my String Quartet no. 4 *Yun Yong* (Clouds surging).



Figure II-29: Rehearsal with Momenta Quartet, from the left to right: Emilie-Anne Gendron (violin), Asmira Woodward-Page (violin), Kee Yong Chong (Composer), Stephanie Griffin, (viola), Michael Haas (cello)

This work reflects my thoughts and feelings on the surging clouds in a natural landscape. Such a landscape was part of my childhood, where the sun glares through the leaves of rubber trees, the clouds surge, and wind and sudden storms in my parents' rubber plantation are deeply engraved in my memory. The clouds are always changing and varying in form. They soar into the vast sky, wild and unconstrained like powerful steeds, never repeating their forms. Sometimes they pose different layers or different colours, running at different speeds, or even in sudden rage.

I was also inspired by the ink painting of my German painter friend Mrs. Helena Belzer as well as moved by the poem "Zhong Nan Retreat" by WANG Wei (poet in the Tang dynasty) when composing this work.

Fragment of the poem:⁶

《終南別業》—王維	"Zhong Nan Retreat" by WANG Wei
行到水窮處，	I walk to the place where the water ends，
坐看雲起時。	And sit and watch the time when clouds rise.

The poem evokes the natural phenomena that inspired the piece: the utterances of the wind, clouds, water, and sky. The use of scordatura on all four stringed instruments enriches the expression of nature in the poem, as I try to achieve an otherworldly colour by avoiding the use of the perfect fifth intervals that stringed instruments are normally tuned in. In addition to the dark and ethereal effect it creates, the scordatura focuses more on timbre than on pitch. The different approaches and techniques found in this piece provide revealing information concerning my compositional orientation from the end of my formal studies to recent years.

Violin I

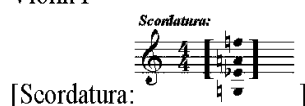

Violin II



Viola

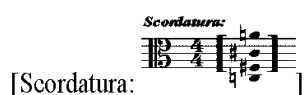

Cello

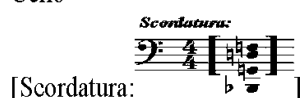

Figure II-30: Scordatura for the string instruments in *Yun Yong*

⁶ Translated by Pauline Yu (1981).

The physical distance between the quartet players creates some technical challenges. It is especially difficult for the players on stage to hear the players at the back of the audience, as many of the sounds are quite subdued. Having to listen carefully for soft cues from across the room is a major disincentive for rushing. In fact, the time it takes to wait and hear what one needs to hear before moving on helps create an elastic and mystical sense of timing. Synchronisation in *Yun Yong* is a huge challenge as all players have to play freely in a half-open and quasi-improvisational manner of their own while remaining coordinated. Along the same lines, the tempo changes and fluctuations are sometimes difficult to coordinate amongst the parts, as the distances between each of the quartet members and lighting change with every different performance venue.

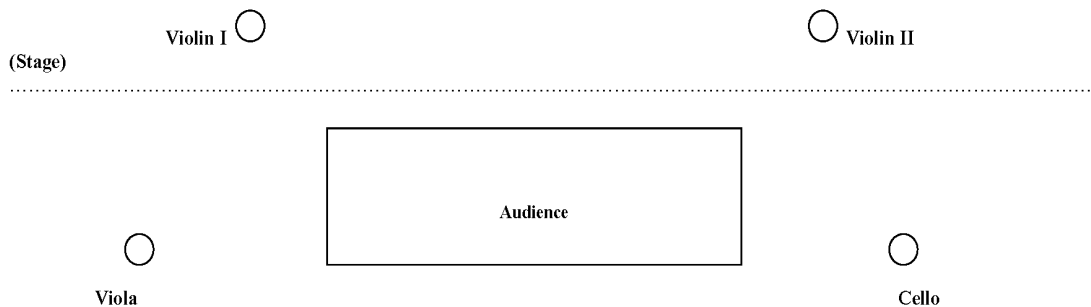

Figure II-31: Instrumental setup of *Yun Yong*

I also made a specific note to the performers that the meter and the bar lines are inserted only for convenience; moreover, irregular rhythms and feathered beams are used to ensure that the music never sounds like it is in 4/4.

Sempre intenso, ma dolce $\text{♩} = 45$

* notated as fingering position (standard tuning), the actual sounding pitches are according to the scordatura tuning of the instrument.

Figure II-32: Bars 1–6, opening section of *Yun Yong*

Ms. Emilie-Anne Gendron, second violinist of the Momenta Quartet, commented on the difficulties of synchronisation in this piece:

In the following Fig. II-34, I employed the quasi-improvisation in a different way for all the players. For example, the cello plays the high register melody according to the notated rhythm; violin I and viola improvise microtonal finger movements to create fluctuation on the written pitches; violin II improvises and continues playing on the given group of pitches.

Figure II-34: Bars 56–61, quasi-improvisation for all the players of *Yun Yong*

Ms. Emilie-Anne Gendron commented on the notation of this piece:

... the way you have notated the piece made it easy for us to use our instincts to figure out where we needed to play precisely, or where espressivo playing and rubato was needed. ⁸

Figure II-35: Bars 95–104, the ending of Section D and the beginning of Section E in *Yun Yong*

⁸ Personal communication with Emilie-Anne Gendron on 31st March 2015.

When Section A is repeated in the recapitulation passage Section I, most of the players play the same notated passage as the first time. However, to present a new articulation, all players employ pizzicato in Section I. This exchange of roles highlights the “living ornamentation” derived from the heterophonic technique in Chinese traditional music. Please compare Fig. II-36 (Section I; bars 171–181) with Fig. II-33 (Section A; bars 17–25).

The image displays a detailed musical score for four string instruments: Violin I (Vln. I), Violin II (Vln. II), Viola (Vla.), and Violoncello (Vc.). The score covers bars 171 to 181. At the top, there are performance directions: "Piu mosso, stesso" with a tempo marking of quarter note = 55, and "string. e intenso". The score is filled with complex rhythmic notation, including many sixteenth and thirty-second notes, and various dynamic markings such as ppp, pp, p, mf, f, and ff. There are also numerous performance instructions like "play on the indicated strings (I-IV)", "arco", "pizz.", "vibr. gliss.", "slow gliss.", "exp. gliss.", "not harm close to the bridge", "p-mp dynamic fluctuations regularly", "multo vbr. (freely)", and "nat. harm. gliss (freely)". The notation includes stems, beams, and various articulation marks.

Figure II-36: Bars 171–181, beginning of Section I, with new materials for the half-open and quasi-improvisational imitation passage for all the players of Yun Yong

The melodies of the high harmonic improvisation of Violins I and II end Section J with the imagery of wind blowing past the bamboo plantation and rocky mountains, stirring a sense of desolation and loneliness.

The image shows a musical score for the piece "Sereno e lontano" by Yun Yong, starting at bar 182. The score is for Violin I, Violin II, Viola, and Cello. The tempo is marked as "♩ = c.35". The score includes various dynamics such as *ppp*, *mp*, *f*, and *pp*, along with performance instructions like "enter impressively", "molto vibr. (freely)", "molto esp.", "arco osc.", "bollo esp.", "dynamic fluctuations irregularly", "improv. in highest register on 4 strings", "with whistling", "Senza misura", and "Completely silent". The score is divided into two systems, with the first system ending at bar 194 and the second system starting at bar 194. The score includes various musical notations such as slurs, accents, and dynamic markings.

Figure II-37: Bars 182–199, high harmonics improvisation contours of Violins I and II in the ending section of the piece of Yun Yong

5. Timeless echoes (2010)

Timeless echoes grew out of collaboration with cellist Arne Deforce, visual artist Sigrid Tanghe, live electronics Jean-Marc Sullon, and Patrick Delges from the Centre Henri Pousseur, and was premiered on 19 November 2010 at the Festival Images Sonores, Église Saint-André, Liège (Belgium). This piece was a residency project commissioned and supported by the Centre Henri Pousseur, dedicated to all its collaborators.

My aim in this composition is also to encourage a kind of multicultural musical performing art while enhancing the intrinsic understanding of what constitutes multicultural and multidisciplinary exchange between musicians and audiences. *Timeless echoes* incorporates multiple influences that are interwoven with or superimposed on my artistic concepts and compositional techniques.

Timeless echoes is inspired by guqin music. The guqin (Ch'in) is a plucked 7-string Chinese musical instrument of the zither family and has traditionally been favoured in ancient China by "wen ren" (文人 i.e. man with scholarly knowledge and understanding of the arts). As with the previous work, scordatura is applied. Strings I and IV of the cello are retuned to lower pitches, with the IV string "a"-quarter tone sharp and the first string "f" quarter tone sharp, to create darker sonorities in the instrument. The tuning is illustrated as follows:



Figure II-38: The tuning of cello

In the opening section, the cello exclusively plays pizzicatos on harmonic and normal pitches to imitate the characteristic sound and timbre of the guqin:

* notated as fingering position (standard tuning), the actual sounding pitches are according to the scordatura tuning of the instrument.
 ** pedal numbering for the live electronics.

Figure II-39: Bars 1–5, opening section of *Timeless echoes*

This piece was written in memory of Chinese composer Wu-Ping Mo, a young composer who died in Paris in 1993 at the age of 32, whom I never met but greatly respect. In this piece, I tried to put different elements together to depict a special artistic expression by means of contrast and alternation. I extended the elements of rhythmic progression in the live performance of a Western instrument, the cello, with live electronics and pre-recorded audio that comprised sound samples from the drone-like cello’s sustaining mixed sound texture, the guqin’s characteristic playing, human voices, wind bells, thus engaging the cello in a dialogue from afar.

In the pre-recorded sound materials, I used very short voice fragments of the Chinese northern-west Shangbei folk song “San Shi Li Pu” (三十里鋪) sung by composer Wu-Ping Mo in his composition *Fan I*. This melody is derived from a well-known peasant song from the mountains. In addition to Mo’s voice, I employed scordatura on the cello to form a complex cello orchestra sound mass in dialogue with the guqin sound fragments, consisting of sliding noises, harmonics, and different plucking sounds.

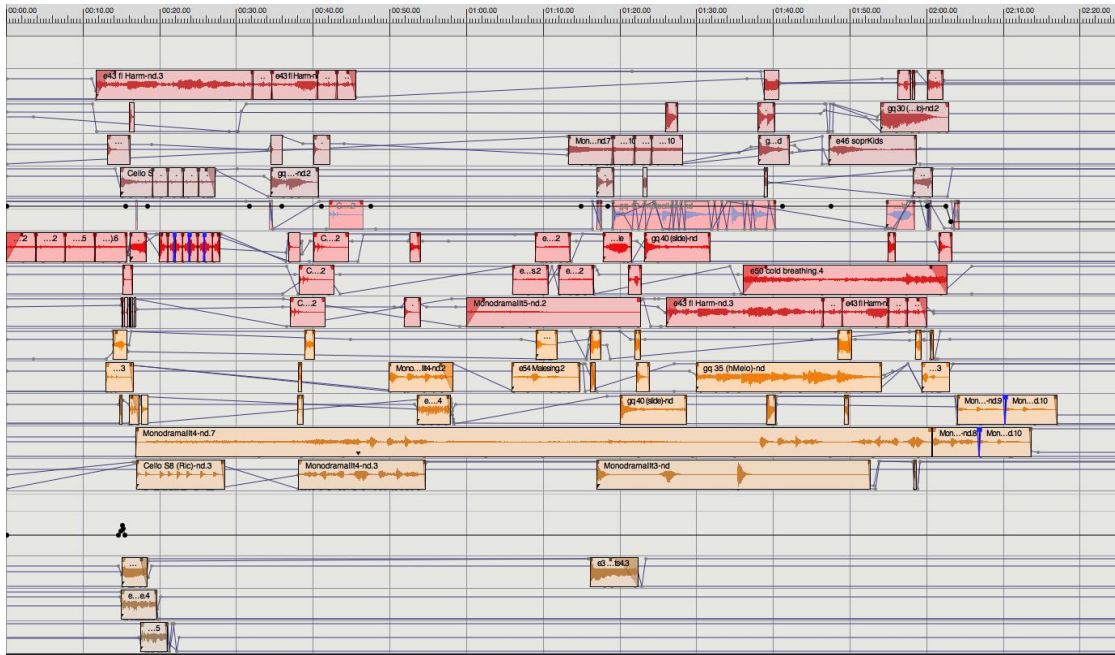

Figure II-42: Track 3 (retrograde of B) of the pre-recorded audio file of *Timeless echoes*

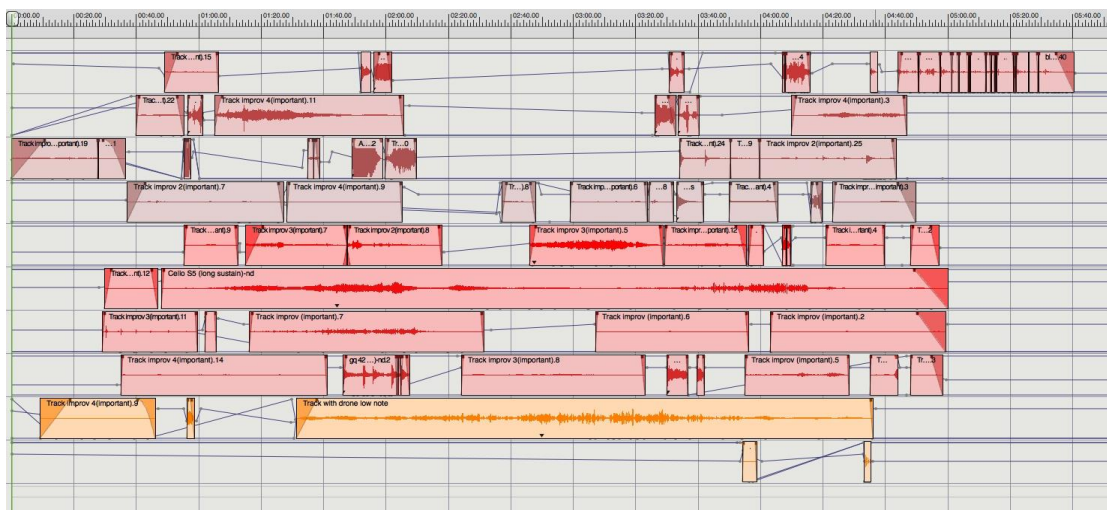

Figure II-43: Track 4 (retrograde of A) of the pre-recorded audio file of *Timeless echoes*

This composition saw the fruition of my exploration of the sonic possibilities of acoustic instruments with the use of modern technology via live electronics and video projection on live painting components.

I have been moved by Belgian painter Sigrid Tanghe’s visual art works and her live painting performances on stage. Her live painting in this work demonstrates my passion in exploring the relationship among the guqin repertoire, Chinese calligraphy, and ink painting. The live painting creates a sensation of being submerged into an antique Chinese drawing that is full of different layers of colours in the visual projection. All these visual layers, acoustic sounds, sonorities, and textures consist of transformations characterised by the yin-yang dialectics of Chinese philosophy. The basic structure of this composition reflects the life circle:

Basic structural of the piece:

Live painting: Emptiness --Black color--start colorful painting--Active coloring--Watering painting--fade the color--most colors fade by pouring more water--Quasi-Emptiness
Cello solo: Silent-----Plucking---- Sliding pizz.-----start Bowing-----Active bowing & emotional-----Sliding pizz-----Plucking-----Silent
Electronic (Tape): Track 1-----Track 2-----Track 3 (mutation from Track 2)-----Track 4 (mutation from Track 1 add bell in the end)

Figure II-44: Basic structure of *Timeless echoes*



Figure II-45: Performance of *Timeless echoes*, painter Sigird Tanghe and cellist Arne Deforce. (Photo credited Virginie Schreyen)

Furthermore, I was inspired by the perspectives provided by the collaboration from both the artist and from 'cellist Arne Deforce. Sigrid Tanghe brought her conception of freedom and responsiveness of live calligraphic action to the project and commented:

This is my first collaboration with composed music, quite different from my previous stage experiences. Because of the rigid nature of composition the performance loses in terms of spontaneous interaction, but wins in structural strength at once. For me, it's another type of work, of preparation. I have to be ready to do the right move on the right moment. The hyper concentration, every performer needs is the same in both improvised and composed music. The adventure of performing happens on another level.⁹

In this composition, I aim to demonstrate a coordinated control of articulation and inflection in pitch, timbre, and intensity, while exploring the articulatory and vibratory characteristics of the cello and experimenting the guqin's playing techniques on the cello.

Using an empty wine-bottle we experimented diverse possibilities on how we could achieve a qualitative gliding pizzicato sound that could imitate or "echo" the typical sound characteristics of the GuQin. I

⁹ Personal communication with Sigrid Tanghe on 4th April 2015

remember in the beginning I played that particular passage improvised within the spirit of the written music. Improvising I searched for interesting inflections in pitch, timbre, and intensity that were musically convincing so I could learn about the “idea” the composer had written down. In a later stage I tried and studied the “bottle-neck” technique to come closer to the text, match the score and refine the playing technique. ¹⁰



(c) Evy Ottermans - 2010

Figure II-46: Cellist Arne Deforce performing the “Bottle-neck” technique on his cello to imitate the guqin in *Timeless echoes* (Photo credited Evy Ottermans)

[sliding gesture is more important than producing audible pitches!]
sliding with side of thumb!

ord. gliss. s.l. L.H. R.H. s.p. sfz mf molto espr. p sfz p mf

(pizz. sempre) ord. s.p. ord. s.p. ord. sfz pp f sfz pp f sfz sub molto legatiss.

A $\text{♩} = c.40$ slow gliss. gliss.

R Dy PS 0% 0% 75% 0%

Painter Elec.

* sliding with the body of wine bottle as "bottle-neck"

Figure II-47: Section A, bars 7–9, “Bottle-neck” technique on the cello

In the following examples, the notated melodies at the extremely high register and the quasi-improvisational melodic contours at the high register form similarly emotional yet differently liberated lyrical melodies in the composition. Mr. Arne Deforce remarks on this compositional approach:

¹⁰ Personal communication with Arne Deforce on 25th March 2015

In other sections like the bowed “quasi impromptu” and the “luminoso”-passage the performer has to take a similar liberate and imaginative approach towards the notation. At several stages I have experienced the pitch notation is better off when seen as pitch “location” giving focus to a refined information on how a certain passage could be played or “worked out”. Hence I consider the score more as a notational image (representation) of the sounds location, the gestures to be performed on the instrument, giving a detailed sense of the structure, the flux, the timbre and energy of sound. ¹¹

Figure II-48: Bars 72–76, melody played on the extremely high register of the cello

Figure II-49: Bars 91–100, improvisation section and improvisation-like melody (bars 97–100) played on the extremely high register of the cello

In the closing section, the cello plays pizzicatos as it does the opening section while the tape part (Track 4) presents a retrograde of Track 1, and the visual part slowly fades away as the water slowly washes away.

Figure II-50: Bars 120–124, Section R, recapitulation section of *Timeless echoes*

¹¹ Personal communication with Arne Deforce 25th March 2015

Chapter III. My compositional philosophy and approach to an East–West aesthetics of today

In this chapter, I discuss the key aspects of my compositional style and how I approach East–West aesthetic confluence in my compositions. Particularly, one of my compositions *Yuan-Liu* is used as an example to elaborate the key stylistic elements and the cultural interactions in my compositions.

From 1997 to 2004, I avoided including any Eastern instrumentation in my compositions. I composed solely for Western instrumentation, aiming to study its potentials and to learn from the Western tradition. In those compositions, I used Eastern aesthetics from Asian music traditions through the use of single tones, heterophonic writing, vocalisation, ornamentation and tuning, with an emphasis on timbre in a Western compositional language. From 2005 onwards, I started employing both Eastern and Western instruments. My first composition of this kind was *Metamorphosis VI-Wind prayer* (2005) for 37-reed traditional soprano sheng, gu zheng, pipa, and Western ensemble.

The first Western-notated composition with an Eastern aesthetic by which I was inspired was the 漁歌 *Yü Ko* or *Fisherman's Song* (1965), composed by Chou Wen Chung. *Yü Ko* is scored for alto flute, English horn, bass clarinet, 2 trombones, 2 percussionists, piano, and violin. This work is

originally an ancient ch'in (zither)¹ melody in tablature notation composed by Mao Min Chung (c. 1280). The fisherman is a symbol of man in communion with nature. Through the deciphering of the tablature notation, this work produces a modern adaptation that realizes the rich variety in tone production found in the precise ch'in finger technique, one that employs over a hundred symbols to achieve an elusive yet vital expression that is the essence of this art (Chou, 2010).

In this work, Chou clarifies how he approaches this process of adaptation (2010):

I have magnified . . . these inflections in pitch, articulation, timbre, dynamics and rhythm to a more perceptible level by expanding the articulations and timbres possible on each instrument used and by controlling the microtonal modifications in pitch according to the nature of each instrument.

In 1968, Prof. Chou first proposed his “re-merger” compositional aesthetic:

¹ “A Chinese long zither, one of the family of east Asian zithers that includes the Japanese *KOTO*, the Korean *Komungo* and the Vietnamese *dan tranh*. . . . The Ch'in has seven strings of equal length and varying thicknesses, each being twisted from a fixed number of silk strands. Unlike other Chinese and east Asian zithers, the ch'in has no bridges. Fingers positions are marked along the soundboard by 13 inlaid ivory or mother-of-pearl discs” (“Ch'in,” 1980, p. 245).

It is my conviction that we have now reached a stage in which the beginning of a re-merger of Eastern and Western musical concepts and practices is actually taking place. By "re-merger" I mean that I believe the traditions of Eastern and Western music once shared the same sources and that, after a thousand years of divergence, they are now merging to form the mainstream of a new musical tradition (Chou, 1968, p. 19).

What I have been speaking of is not a "new" culture, but a "merger" or "re-merger" of legacies, not cultural "influence" but a "confluence." In contrast to "borrowing" by the West from the East in the past, or the East from the West today, "merger" means coming together, sharing each other's heritage, complementing and revitalizing legacies (Chou, 2001).

I am deeply interested in how the new East-West aesthetics in multi-layered cultural and ethnic heritages can influence music. This has played a large part in my compositional approach.

Yuan-Liu (Origin-Stream) is a work for traditional 37-reed soprano sheng, 2 pianos, and 2 percussionists (2009). In Chinese, "yuan" means "source, origin or root"; "liu" denotes "flow, circulate, stream of water." The piece is based on the musical concepts derived from *Wu Yan* for 6 percussionists (2003, rev. 2014) and *Hidden Eternity* for 4 hands piano and ensemble (2006). *Yuan-Liu* was commissioned by and is dedicated to Sheng master Mr. Wei Wu and the Ensemble Berlin Piano-Percussion.



Figure III-1: From left to right: Wei Wu (sheng), Friedemann Werzlau (percussion), Kee Yong Chong (composer), Sawami Kiyoshi (piano), Prodromos Symeonidis (piano), Ya-ou Xie (conductor) and Adam Weisman (percussion)

Yuan-Liu is the second piece of my *Yuan* series. The *Yuan* series start with *Yuan-Fei* (Origin-Fly) for Chinese bamboo flute dizi and five Western instruments (2009), and the third piece is *Yuan-He* (Origin-Harmony), a concerto for 5 Chinese instruments and 5 Western instruments (2010).

源。飛
Yuan-Fei
for Dizi & five Western instruments
Dedicated to Hong Kong New Music Ensemble

Misterioso e luminoso ♩ = c.35

The score consists of six staves: Dizi, Oboe, Clarinet in Bb (sounds a major 2nd lower), Piano, Viola, and Cello. The tempo is marked *Misterioso e luminoso* with a quarter note equal to approximately 35 beats per minute. The key signature is one flat (Bb). The score includes various dynamic markings such as *pp*, *mp*, *p*, *mf*, *sfz*, and *pp*. Performance instructions include "enter softly", "more air sound", "gliss.", "Vibr. speed", "Tone-colour variation", "inside piano", "gliss. over strings", "dolciss.", "pizz.", "S.P. arco", "Sub. sempre", and "Sub. pp". The score is divided into measures with bar lines and includes various musical notations like slurs, accents, and phrasing marks.

Figure III-2: First page of *Yuan-Fei*

源。和 "Yuan. He"

(2010)
Concerto for 5 Chinese instruments & 5 Western instruments
Dedicated to the Ensemble Dragon & Ensemble het Collectief

Tempo rubato ♩ = c.42

The musical score is arranged in ten staves, from top to bottom: Dizi, Ehu, Yan qin, Gu zheng, Sheng, Flute, Violin, Piano, Cello, and Bass clarinet. The score includes various performance instructions such as 'enter softly', 'overblowing (ad lib.)', 'reverse end of the beaters gliss. (freely)', 'play on the normal position', 'left-side behind bridge', 'mute string & play on key', 'tremolo with palm of hand', and 'with fingers tip'. Dynamic markings include *pp*, *mp*, *p*, *sfz*, *f*, *molto*, *ff*, *ppp*, and *sempre*. The score also features articulation marks like accents and slurs, and specific performance techniques like 'l.v.' and 's.v.'.

Figure III-3: First page of *Yuan-He*

The Yuan series is based on the Chinese philosophy about the Wu Xing (five phases): wood, fire, earth, metal, and water. This order of presentation is known as the "mutual generation" sequence. In the order of "mutual overcoming" the elements are presented in the sequence of wood, earth, water, fire, and metal. In *Yuan-Liu*, the system of the five phases is used to describe interactions and harmonious relationships between natural phenomena.

Although *Yuan-Liu* has a strict compositional structure and arrangement of pitches and rhythms, I insert passages of free, personal, intuitive, and repetitive improvisations for each instrument according to the Wu Xing concepts of “mutual generation” and “mutual overcoming”. These dynamic qualities are allied to instructions where, the sheng player and the two percussionists are required to move to different positions on stage to create a sense of uncertainty. Examples are as follows:

Figure III-4: Improvisation passages in Pianos 1 and 2 (bar 27) and the sheng part (bar 28) of *Yuan-Liu*. The score includes staves for Sheng, Percussion 1, Piano 1, Piano 2, and Percussion 2. Annotations include dynamics like *ppp*, *sfz*, *mp*, and *pp*, and performance instructions such as "improv. (freely)", "whilst playing move slowly to the position II", and "take hard felt mallets".

Figure III-4: Improvisation passages in Pianos 1 and 2 (bar 27) and the sheng part (bar 28) of *Yuan-Liu*

Figure III-5: Bar 32, improvisation passages for Percussionist 1 in *Yuan-Liu*. The score includes staves for Sheng, Percussion 1, Piano 1, Piano 2, and Percussion 2. Annotations include dynamics like *sfz*, *pp*, and *ppp*, and performance instructions such as "improv. (freely)", "3 crotales", and "pair of Chinese Cymb.(Small)".

Figure III-5: Bar 32, improvisation passages for Percussionist 1 in *Yuan-Liu*

Figure III-6: Improvisation passages for Percussionist 2 (bar 74) and the sheng part (bar 76) of *Yuan-Liu*

In this work, I use varying time signatures to create irregularity and instability that is informed by the Wu Xing principle. For example, different sections for the sheng part and the time signature changes in each section are as below:

Section A (bars 1–15), Position I (offstage).

Bar	1	2	3	4	5	6	7	8	9	10	11	12	13	14	15
Time signature	4/4	2/4	9/16	5/8	4/4	2/4	3/4	9/16	3/8	4/4	4/4	4/4	5/4	2/4	4/4
Tempo	$\text{♩} = c.35$	--	--	--	--	--	--	--	--	--	--	--	--	--	--
Performance direction	(Fermat $a=F$)		accel	rit	(F)				string.	string.	string.	string.	string.	string.	string.

Figure III-7: Bars 1–11, Section A of the sheng part in *Yuan-Liu*

Section B (bars 16–27), Position I (offstage).

Bar	16	17	18	19	20	21	22	23	24	25	26	27
Time signature	4/4	4/4	3/8	2/4	4/4	2/4	7/16	5/8	4/4	3/4	9/16	4/4
Tempo	$\text{♩} = c.45$	--	--	--	--	--	--	--	--	--	--	--
Performance direction	(Rehearsal mark- A)=RM-A											(RM-B)

Figure III-8: Bars 16–27, Section B of the sheng part in *Yuan-Liu*

Section C (bars 28–60), from bar 29 slowly move from position I (offstage) to Position II (onstage).

Bar	28	29	30	31	32	33	34	35	36				
Time signature	4/4	4/4	2/4	4/4	4/4	9/16	7/16	4/4	5/8				
Tempo	♩ = c.45	--	--	--	--	--	--	--	--				
Performance direction		<i>Improv. and move to position II</i>						(RM-C)					
Bar	37	38	39	40	41	42	43	44	45	46	47	48	49
Time signature	2/4	7/8	5/8	2/4	9/16	7/8	4/4	4/4	5/4	9/16	4/4	4/4	5/4
Tempo	--	--	--	♩ = c.60	--	--	--	--	--	--	--	--	--
Performance direction	Position II			(RM-D)								String.	String.
Bar	50	51	52	53	54	55	56	57	58	59	60		
Time signature	4/4	2/4	9/16	5/8	3/8	2/4	3/4	4/4	2/4	4/4	4/4		
Tempo	--	--	--	--	--	--	♩ = c.45	--	--	--	--		
Performance direction	String.	String.	String.	String.	String.	String.	(RM-E) (F)	(F)	(F)				

Figure III-9: Bars 28–60, Section C of the sheng part in *Yuan-Liu*

Section D (bars 61–75), from bar 61 move from position II to position III.

Bar	61						62	63	64	65	66
Time signature	4/4						4/4	4/4	4/4	4/4	4/4
Tempo	♩ = c.45						--	--	--	--	--
Performance direction	<i>Improv. and move to position III</i>										

Bar	67	68	69	70	71	72	73	74	75
Time signature	4/4	3/4	3/8	9/16	7/16	4/4	2/4	4/4	4/4
Tempo	--	--	--	--	--	♩ = c.45	--	--	--
Performance direction			String.	String.	String.	(RM-F) (F)			

Figure III-10: Bars 61–75, Section D of the sheng part in *Yuan-Liu*

Section E (bars 76–85), from bar 76 move from position III to Position IV.

Bar	76	77	78	79	80	81	82	83	84	85
Time signature	4/4	4/4	4/4	4/4	4/4	4/4	4/4	3/4	9/16	4/4
Tempo	♩ = c.45	--	--	--	--	--	--	--	--	--
Performance direction	<i>Improv. & move to position IV</i>					Reach position IV				(RM-G)

Figure III-11: Bars 76–85, Section E of the sheng part in *Yuan-Liu*

Section C' (bars 86–114), from bar 87 slowly move from position IV to Position V.

Bar	86	87	88	89	90	91	92	93	94
Time signature	4/4	4/4	2/4	4/4	4/4	9/16	7/16	4/4	5/8
Tempo	♩ = c.45	--	--	--	--	--	--	--	--
Performance direction		<i>Improv. and move to position V</i>						(RM-H)	

Bar	95	96	97	98	99	100	101	102	103	104	105	106
Time signature	2/4	7/8	5/8	2/4	9/16	7/8	4/4	4/4	5/4	9/16	4/4	4/4
Tempo	--	--	--	♩ = c.60	--	--	--	--	--	--	--	--
Performance direction	Position V			(RM-I)								String.

Bar	107	108	109	110	111	112	113	114
Time signature	5/4	4/4	2/4	9/16	5/8	3/8	2/4	3/4
Tempo	--	--	--	--	--	--	--	♩ = c.45
Performance direction	String.	String.	String.	String.	String.	String.	String.	(RM-J) (F)

Figure III-12: Bars 86–114, Section C' of the sheng part in *Yuan-Liu*

Section B' (bars 115–126), from bar 115 move from position V (onstage) to position I (offstage).

Bar	115	116	117	118	119	120	121	122	123	124	125	126
Time signature	4/4	4/4	4/4	3/8	2/4	4/4	2/4	7/16	5/8	4/4	3/4	9/16
Tempo	--	♩ = c.45	--	--	--	--	--	--	--	--	--	--
Performance direction	(F) move to position I	(RM-K)										

Figure III-13: Bars 115–126, Section B' of the sheng part in *Yuan-Liu*

Section A' (bars 127–146), Position I (offstage).

Bar	127	128	129	130	131	132	133	134	135	136
Time signature	4/4	2/4	9/16	5/8	4/4	2/4	3/4	9/16	3/8	4/4
Tempo	♩ = c.35	--	--	--	--	--	--	--	--	--
Performance direction	(RM-L) (F)		accel.	rit.	(F)				string.	string.

Bar	137	138	139	140	141	142	143	144	145	146
Time signature	4/4	4/4	5/4	2/4	4/4	4/4	4/4	4/4	4/4	4/4
Tempo	--	--	--	--	--	♩ = c.35	--	--	--	--
Performance direction	string.	string.	string.	string.	string.	(RM-M)			(F)	Completely silent

Figure III-14: Bars 127–146, Section A' of the sheng part in *Yuan-Liu*

The overall form of the sheng part of *Yuan-Liu* indicate a compositional structure that resembles a strictly designed A [A-B]-B [C-D-E-C']-A' [B'-A'] form as follows:

Sheng

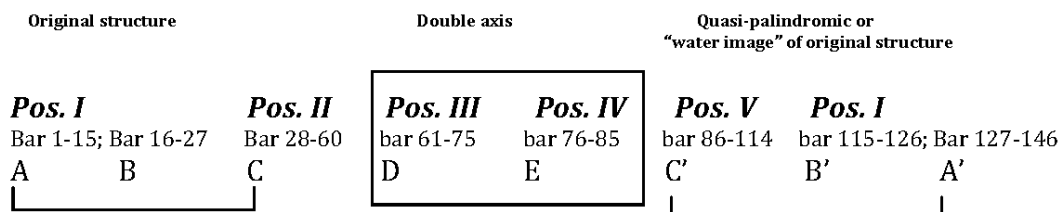

Figure III-15: Compositional structure of the sheng part in *Yuan-Liu*

Given the structured form of *Yuan-Liu*, I add different levels of intuitively performed *punto coronatos* and freely repeated improvisations to prevent the work from becoming overly rigid and mechanical.

With the sheng performer Ms. Ling-Hsuan Shen, I discussed the use of layers of changing parameters to create instability:

... varying time signatures (e.g., 2/4, 4/4, 3/8, and 7/16) is used to signify the change and stability of the five elements, and the stacking and clashing of notes and melodies imitate the mutual generation and overcoming of the five phases...In the performers' improvisation, the five elements interact constantly with one another, yielding similar but different results.²

Furthermore, I would like to elaborate on some key aspects of my compositional style in my works as reference to *Yuan-Liu*.

1. “Water-image” symmetry

Wu Yan for 6 percussionists was the first time I explored the idea of “water-image” symmetry, introduced by Wen Chung Chou. In both Chinese and Western traditions, symmetry has played an important role in shaping musical compositions.

Chou's concept of symmetry is based on “water-image” where the objects remain unchanged; however, images reflected in water are distorted as a result of the refraction of light. Chou's understanding of symmetry accords with the balanced dynamic forces apparent in many Chinese art forms, including calligraphy, landscape painting, music for the qin, and poetry. It is precisely this characteristically flexible approach to symmetry (i.e, “water-image” symmetry as opposed to “mirror-image” symmetry, also called reflective, geometric, or mathematical symmetry) that reveals the divergence and re-merging of traditional Eastern music and contemporary Western music (Pan-Chew & Chen, 2010).

I designed this work in quasi-palindromic or quasi-“water-image” symmetry, with a double-axis section E and F as middle section of the whole piece. After the double-axis section, in the quasi “water-image” symmetry section, I rearranged the sections as Sections C and D and inserted the diminution Section E, continuing to Sections A' and B', and ending with a coda. In the coda, the stage lights are fading, the volume of each instrument and vocalisation of the percussionists gradually weakens. Before all sound completely disappears, percussionists walk slowly to offstage positions. Percussionist 3 is left onstage to perform an improvisation to create a continuous, linear music composed of points of sound that recall the natural sound of water.

Below is a diagram of the structure of the composition:

² Personal email communication with sheng soloist Ms. Ling-Hsuan Shen on 16th March 2015.

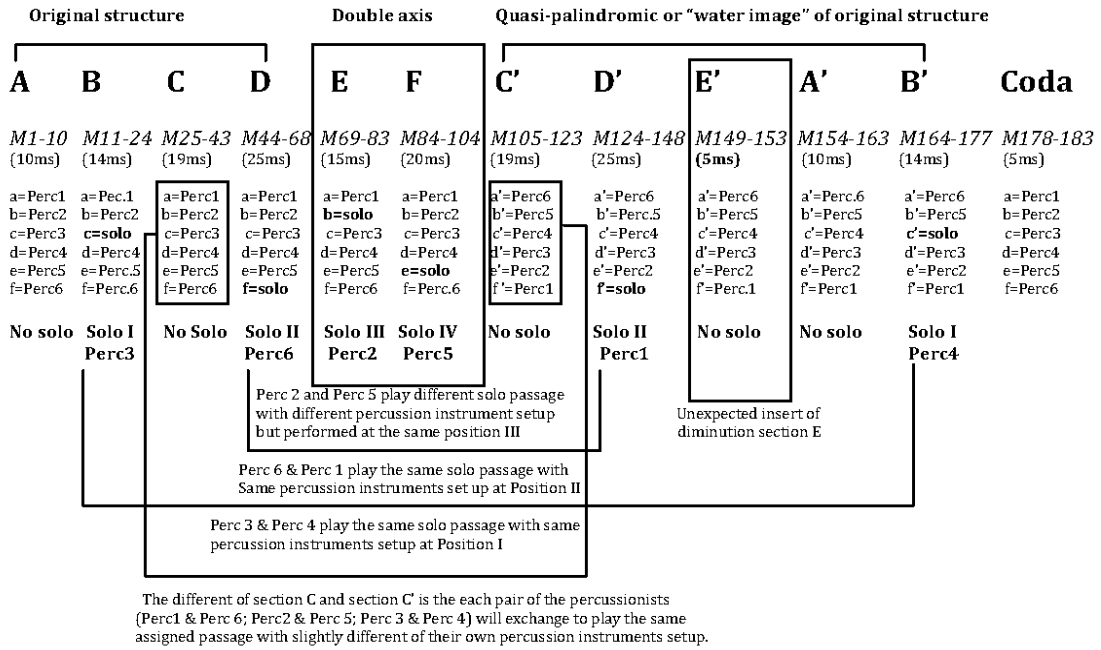

Figure III-16: Compositional structure of Wu Yan

In the following examples, music in Section A and Section A' (also Section B and Section B') appears similar and involves the same percussion instruments. However, the different tuning of the instruments and the exchange of passages performed by each pair of percussionists produce subtle changes to the music.

Below are score examples of Section A and Section A':

The score for Section A, bars 1-4 of Wu Yan, is a complex arrangement for six percussionists. The tempo is marked as $\text{♩} = c.35$. The score includes the following parts and instructions:

- Percussion 1:** bass drum (with hands), R-H (fingers), Long!, *pp*, rapid, dense trem., L-H, *sfz*, *p*, *sfz*, *molto pesante*, *mp*, L.v., *accel.*, *rit.*, *scratch quickly (sharp accent)*, *sfz*, L.v.
- Percussion 2:** 2 tam-tams (L/M), Long!, gong beater, triangle beater on the rim, *pp*, *delicato*, *ppp*, *metal mallets*, *sfz*, *p*, *mf*, L.v., *scratch quickly (sharp accent)*, *sfz*, L.v.
- Percussion 3:** crotale on timp., Long!, metal mallets, *sfz*, *p*, *mf*, L.v., *metal mallets*, *sfz*, *p*, *pp*, L.v., with wooden mallet, *pp*, L.v., *pedal gliss.* (independently than Perc.4), *ad libitempo*, *sfz*, *pedal gliss.*, *p*, *sfz*, *pp*
- Percussion 4:** crotale on timp., Long!, metal mallets, *sfz*, *p*, *mf*, L.v., *metal mallets*, *sfz*, *p*, *pp*, L.v., with wooden mallet, *pp*, L.v., *pedal gliss.* (independently than Perc.3), *ad libitempo*, *sfz*, *pedal gliss.*, *p*, *sfz*, *pp*
- Percussion 5:** 2 tam-tams (L/M), Long!, gong beater, triangle beater on the rim, *pp*, *delicato*, *ppp*, *scratch quickly (sharp accent)*, *sfz*, L.v., *scratch quickly (sharp accent)*, *sfz*, L.v.
- Percussion 6:** bass drum (with hands), R-H (fingers), Long!, *pp*, rapid, dense trem., L-H, *sfz*, *p*, *sfz*, *molto pesante*

Figure III-17: Section A, bars 1-4 of Wu Yan

Figure III-18: Section A', bars 154-157 of *Wu Yan*

Below are score examples of Section B and Section B':

Figure III-19: Section B, bars 11-13, of *Wu Yan*

Figure III-20: Section B', bars 164–166, of *Wu Yan*

In *Yuan-Liu*, the sheng represents the oldest Eastern tradition, and the two pianos represent the strong Western tradition, while remaining substantially related to the percussion instruments that serve as a medium between the East and West. In addition, this work marks the second time I explored the idea of “water-image” symmetry introduced by Wen Chung Chou.³

I was deeply influenced by the later works of Anton Webern. Particularly, I am impressed by his strict employment and concept of sequence in passages that are mirror-symmetrical in interval, rhythm, dynamics, and timbre. His renowned *Symphonie*, Op. 21 (1927-28) and *Variations for Piano*, Op. 27 (1936) are apt examples of the technique.

Although I am tremendously impressed by Anton Webern’s introduction of strict symmetrical mirror structures and his radical musical concept, my compositions are more inspired by the nature of all the irregular patterns and the “water-image” introduced by Wen Chung Chou.

My use of “water-image” symmetry is not reflected in parameters such as pitch, rhythm, and dynamics. Instead, I focus more on devising an overall structure informed by “water-image” symmetry. The double axis of the “water-image” structure appears more like lake reflections of Nature that, when blown by wind or affected by external forces, present irregular images of the original landscape.

³ The “water-image” symmetry is further elaborated in the discussion of my composition *Wu Yan* for 6 percussionists in this chapter, p. 67.

2. Coordinated control of articulation, inflections in pitch, ornamentation, timbre, and intensity in my compositions

My early work *Liu-Xu-Fei* (柳絮飛) [2001] for oboe and cello is an illustration of how I tried to explore these two instruments' articulatory and vibratory characteristics. The title *Liu-Xu-Fei* is a quotation from a poem by poet/painter/musician Wei Wang (699–759) from the Tang dynasty. The title means: "willow catkins hover or flutter in the air." This work, which reflects the sensation of this poem, presents the solitude between the two instruments. I'd like to express the feeling, depicted in the poem, of watching the willow catkins hover in the air with an evocative melody and cantilena achieved through figurative reiterations, sustained sonorities, and fluctuations in dynamics and pitch.

Title: Harmonizing a poem by Palace-Attendant Kuo
By Wei Wang (Tang dynasty)

"Where peach and plum are blooming and the willow-cotton flies."⁴

「桃李陰陰柳絮飛。」——唐·王维《酬郭給事》

The heterophony and written out "living ornamentation" techniques are well elaborated in this composition, given these techniques are rooted in many Asian traditions. In traditional Asian music, with simple, gentle lines—mainly reflected in the melody, tempi, rhythm and form—the process of "improvisatory decoration" is one of the ways to strengthen the heterophony in a composition. Traditional Asian music often integrates different types of vibrato techniques when playing an instrument or singing. These techniques are different in type and speed, they use fast and slow changes in tone and pitch, in small and large intervals around a primary tone to modify the sound.

Heterophony created through ornamentation is a characteristic of several contemporary Asian composers such as Wen Chung Chou whose work uses a "single tone" technique that is highly elaborated as does Isang Yun through his "Hauptton" (main-tone) techniques. Isang Yun has described this technique as follows:

The fundamental element of my compositions is, to put it concretely, an individual tone (Einzelton). A countless number of variant possibilities inhere in an individual tone, to which surrounding elements such as appoggiatura, vibrato, accent, after notes and other ornamentations belong, in order to establish the foundation of the composition. I call this individual tone a main tone (Hauptton; Song, 1973, p. 35).

As for my term of "living ornamentation", from what I understand, the traditional ornamentation is part of the structure of the whole composition. Traditional Asian musicians relied on oral teaching and passed on their way of

⁴ This translation was derived from Bynner and Kiang (1922, p. 241).

interpretation to their students from generation to generation. The ornamentation in the piece is a living configuration where the shape of the music is constantly changed by different generations. This is part of the essence of the flexibility in traditional music.

In *Liu-Xu-Fei*, my reason for writing down all of the “living ornamentation” for Western musicians is because I wanted both the oboist and cellist to bring out the Eastern sensibility, even without knowing any Eastern traditional ways of interpretation!

In *Liu-Xu-Fei*, the entries of the two instruments are not in unison or on the same pitch, but their pitches are slightly different. For example, at rehearsal mark A, the cello starts with a long, sustained B-flat with different written-out ornamentations, whereas the oboe enters later in the same octave a quarter tone lower imitating the cello using variants of its ornamental structure.

This approach to difference is in part influenced by Balinese gamelan music where most Kebyar instruments are grouped in pairs and are tuned slightly differently from each other to represent “female” and “male.” This tuning system creates an intermingling of the instruments’ sonorities and characteristics.

One striking characteristic of many Balinese ensembles is that the key instruments come in matched pairs...The keys of one instrument are tuned to be slightly lower in pitch than the keys of the other. When the corresponding keys on the two instruments are struck at the same time, the ear perceives not two dissimilar notes, but rather a single note that seems to shimmer and dance because it oscillates quickly between louder and quieter. This effect is the result of an acoustical phenomenon known as beating. (Spiller, 2004, p. 120–121)

In the final section, at rehearsal mark C, the sustained, single tone F-sharp is first played by the oboe whilst the cello subsequently plays the same pitch two octaves down with different articulation and ornamentation. Rehearsal mark C uses the same musical ideas as at rehearsal mark A, but now the primary line starts with the oboe in another sustained F-sharp and the cello moves two octaves lower with the same pitch as the sustained note but with trills as ornamentation. So this recapitulation section (rehearsal mark C) is transformed into a different level of articulatory and vibratory characteristics, compared to the opening section (rehearsal mark A).

Figure III-22 shows the musical score for the opening section of rehearsal mark A of *Liu-Xu-Fei* for oboe and cello. The score is in 3/4 time and marked "Lamentoso". The oboe part starts with a sustained note, followed by a series of trills and ornaments. The cello part starts with a sustained note, followed by a series of trills and ornaments. The score includes various performance instructions such as "flexible, not strict tempo!", "Circum breathing", "enter perceptibly", and "M = multi-phonic". There are also notes about the dotted barline and the quarter-tone.

Figure III-22: Opening section of rehearsal mark-A of *Liu-Xu-Fei* (柳絮飛) for oboe and cello (2001)

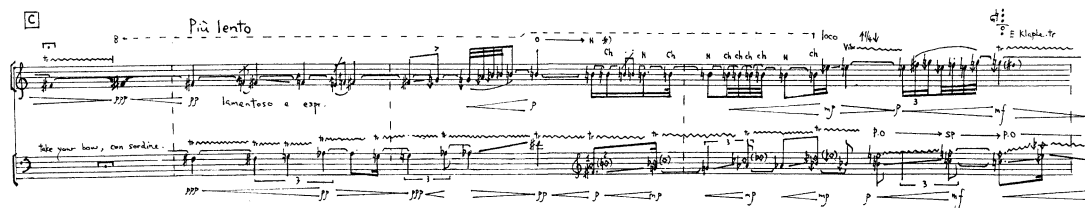

Figure III-23: Recapitulation section (rehearsal mark C) of *Liu-Xu-Fei* (柳絮飛) for oboe and cello (2001)

In *Yuan-Liu*, this “living ornamentation” mainly happened in the traditional soprano 37-reed sheng part, for examples as below.



Figure III-24: Bars 6-10, the sheng part performs different types of tremolo and grace notes in *Yuan-Liu*

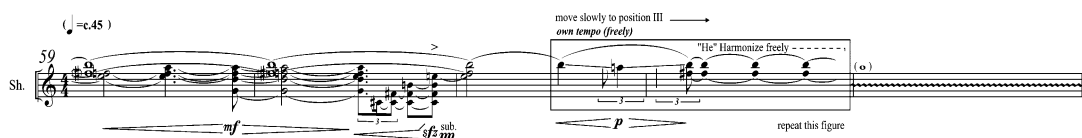

Figure III-25: Bars 59-63, in bar 61, the sheng employs the traditional ornamentation techniques “He” (adding free notes to create different chords)

3. Tuning systems

The *Metamorphosis* series is more than just a variation of my previous compositions; it is a sublimation or mutation of the same musical idea or emotional condition. *Metamorphosis I* for viola and harp (2000, revised 2007) is the first piece of this series, based on my earlier work *The reflection of the dancing ghost* (1999) for bassoon and harp. The viola and bassoon share the same musical and emotional background presented by the harp.

In *Metamorphosis I*, the microtonal scordatura of the harp and viola creates a mixture of pure and non-pure fifth tunings. As an emulation of non-Western sound qualities and Eastern performance techniques and philosophies in my early composition, I studied and applied the just intonation system. The ancient Chinese tuning system is based on just intonation with the cycle of fifths and fourths to form a chromatic scale. By rising a fifth and dropping a fourth via the numerical ratios of 2:3 and 4:3, a series of twelve pitches is produced. Although these 12 Lü frequencies approximate the 12 chromatic pitches known in the West, some of the notes are a bit flat or sharp to our ears as the Chinese system does not use equal tempered tuning. This tuning system forms the basis of the pentatonic mode frequently used in Asian traditional music (especially in Korean court and folk music, Japanese gagaku music, gamelan music, Thai piphat music, and many others).

Note Names (12-note system, for one octave)⁵

黃鐘- Huáng Zhōng	unison
大呂- Dà Lǚ	semitone
太簇- Tài Cù	major second
夾鐘- Jiá Zhōng	minor third
姑洗- Gū Xiǎn	major third
中呂- Zhōng Lǚ	perfect fourth
蕤賓- Ruí Bīn	tritone
林鐘- Lín Zhōng	perfect fifth
夷則- Yí Zé	minor sixth
南呂- Nán Lǚ	major sixth
無射- Wú Yì	minor seventh
應鐘- Yìng Zhōng	major seventh

The ancient (pre-Tang) names of the five notes of the pentatonic scale are:

gong (宮, gōng)	The first note in the Chinese pentatonic scale.
shang (商, shāng)	The second note
jue (角, jué)	The third note
zhi (徵, zhǐ)	The fourth note
yu (羽, yǔ)	The fifth note

The five notes correspond to: do, re, mi, sol, la

Chinese ancient (The Yellow Emperor period, 2650 BC) "12 Lü" chromatic scale based on 2:3 and 4:3 (perfect fifth and perfect fourth) ratios intervals.

The image shows a musical staff with 12 notes. Below the staff are two rows of labels. The first row contains the names of the 12 Lü: 黃鐘, 大呂, 太簇, 夾鐘, 姑洗, 中呂, 蕤賓, 林鐘, 夷則, 南呂, 無射, 應鐘, 清黃鐘. The second row contains their pinyin: Huáng Zhōng, Dà Lǚ, Tài Cù, Jiá Zhōng, Gū Xiǎn, Zhōng Lǚ, Ruí Bīn, Lín Zhōng, Yí Zé, Nán Lǚ, Wú Yì, Yìng Zhōng, Qīng huáng Zhōng. Below this, a pentatonic scale is shown with five notes: 宮 (Gong), 商 (Shang), 角 (Jue), 徵 (Zhi), 羽 (Yu). The notes 變徵 (Bian zhi) and 變宮 (Bian gong) are also indicated below the pentatonic scale.

The ancient (pre-Tang, before AD 618) pentatonic scale

Figure III-26: Chinese ancient chromatic scale based on 2:3 and 4:3 (perfect fifth up and perfect fourth down) ratios intervals⁶

⁵ “The pentatonic scale is used more often in Chinese music: many confucianists insisted on the use of the pentatonic scale, regarding C, D, E, G and A as the “right” notes (cheng-sheng 正聲) and F# and B as the “varied” notes (pien-sheng 變聲) The pentatonic and heptatonic scales were systematized mathematically and physically into a 12-note system, which differed slightly from the modern equal-tempered chromatic 12-note system since it consisted of alternate perfect 4ths and 5ths, which were derived through a method similar to that used for the Pythagorean scale. The Chinese invention was made almost simultaneously with Pythagoras’s, but the historical relation between them has not been established (“China_II Court traditions (ya-yueh),” 1980, p. 252).

⁶ This figure is created according to the materials from Chen (2002) and Chu (n.d.).

Figure III-27 illustrates how the cycle of fifths and fourths based on the 12 chromatic notes is re-ordered to form three basic sets of 5-note pentatonic scale.

Just intonation with the cycle of fifths (2:3) and fourth (4:3) ratios → Re-order into: Pentatonic in "Do" (Gong) mode

Do Re Mi Sol La Do Re Mi Sol La Do Re Mi Sol La
 宫 商 角 徵 羽

Figure III-27: Just intonation with cycle of fifths and fourths that is re-ordered to form three sets of pentatonic scales in "Do" mode⁷

In traditional and folk music from Asia, the tuning of perfect fifths and its inversions (perfect fourths) are important for instrument tuning and the harmonisation of the melodic lines. For example, in Chinese traditional music, the sheng (mouth organ) always uses perfect fourths or fifths to harmonise or reinforce its melodic line.

a. b. c. d. e. f.

a. Gao Hu tuning d. Liu Qin tuning
 b. Er Hu tuning e. Pipa tuning
 c. Zhong Hu tuning f. Zhong Ruan tuning

Figure III-28: Some of the tunings of Chinese instruments

Figure III-29: Sheng playing D major scale with perfect fifth and octave as harmonisation

I simulated the non-tempered tuning (just intonation) of Chinese traditional instruments and attempted to show the versatility of the two Western instruments by presenting phrases, melodies and structures of traditional Asian folklore music. This work requires the viola to tune the strings to *C*, *G* quartertone flat, *D-flat*, and *A* quartertone flat, while the harp retunes two pitches, *C* natural quartertone flat and *D-3-quartertone flat* (see the instructions below). The relationship of the tuning between the two instruments is: the harp's *C* quarter-tone flat will accord with the viola's *G* quarter-tone flat as a "pure" perfect fifth interval, and the harp's *D 3-quarter-tone flat* will accord with the viola's *A 3-quarter-tone flat* forming a "pure" perfect fifth interval.

The viola's scordatura with non-pure fifth tuning is as follows:

⁷ This figure is created according to the materials from Chen (2002) and Chu (n.d.).

Ex: Viola tuning

Figure III-30: **C natural** and with **G quartertone flat**, **D flat** and with **A 3-quarter tone flat**. These two pairs of non-pure fifth open strings are the main musical elements in this work.

The harp is only retuned on two pitches:

Ex: Harp tuning

Figure III-31: **C quartertone flat** and **D flat quartertone flat** throughout the whole piece

In Southeast Asian ethnic and folk music, which uses the just intonation tuning system, the semitone interval between notes E and F as well as B and C are smaller than in the well-tempered system, and just major second intervals are larger than well-tempered major seconds. The "non-pure" second intervals are very important in the melodic writing of my composition. Therefore, I integrated the mixture of the "non-pure" second intervals, that is "*C quarter-tone flat*" to "*D flat*" (also including the smallest step *C natural* and *D flat quarter-tone lower*) and *G quarter-tone flat* to *A flat* (also including the smallest step *G natural* and *A flat quarter-tone flat*).

Figure III-32: Opening section of *Metamorphosis I* for viola and harp (2000, rev. 2007)

In Balinese gamelan music, most Kebyar instruments are grouped in pairs and tuned slightly different from each other to signify “female” and “male.” This tuning system intermingles the instruments’ sonorities and characteristics. In addition to the influence of gamelan from Bali on my compositions, I refer to harmonic / nonharmonic species in Western spectral music during musical composition. When two or more sounds are arranged as a harmonic series in a harmonic spectrum, they produce compound timbres that are harmonic or stable. By contrast, when two or more sounds are not integrated or are intricately related, the sounds clash with one another and generate a nonharmonic spectrum. In this case, the fundamentals are difficult to identify, causing different levels of harmonic tension that create beats between sounds.⁸

During my study in Belgium, I was deeply influenced by the works composed by Italian composer Giacinto Scelsi in the early 1990s. Since then, I have started to explore the spectral features of tuned musical instruments. Many of Scelsi’s works demonstrate his understanding of the acoustic features of the spectra of different musical instruments. For instance, in Scelsi’s “Anahit” for violin & 18 instruments (1965), the soloist’s violin is retuned to G-G-B-D to produce more intense and ethereally plaintive sound. Drastic tuning thoroughly alters the timbre of a musical instrument, creating a unique reverberation within the instrument itself. Similar techniques can be found in my works such as *Timeless echoes* (Figure III-33) and *Yun Yong* (Figure III-34).

* notated as fingering position (standard tuning), the actual sounding pitches are according to the scordatura tuning of the instrument.
 ** pedal numbering for the live electronics.

Figure III-33: Bars 1-5, cello scordatura in *Timeless echoes*

* notated as fingering position (standard tuning), the actual sounding pitches are according to the scordatura tuning of the instrument.

Figure III-34: Bars 1-5, scordatura of all the string instruments in *Yun Yong*

⁸ See technical explanations of spectral music in Joshua Ginsberg (2000), Guide to basic concepts and techniques of spectral music. *Contemporary music review*, 19, 81-113 (p. 91).

In *Yuan-Liu*, I avoided using keyboard percussion instruments with well-tempered pitches and turned to mostly unpitched or approximate-pitched percussion instruments. A similar approach can be found in my previous composition *Wu Yan* and most of my percussion compositions.

The percussion setup of this piece is based on a palindromic design. The instruments in Position I of Percussionist 1 are the same as those in Position I of Percussionist 2. The only difference between the two lies in the pitches or approximate pitches played by the instruments. This technique bears similarities with “male” and “female” tuning systems as found in gamelan.

The score is for *Yuan-Liu*, starting with a tempo of *Tempo rubato* at a quarter note equal to approximately 35 (♩=c.35). The score is divided into five staves: Sheng, Percussion 1, Piano 1, Piano 2, and Percussion 2. The Sheng part begins with a *Pos. I* section, marked *enter softly ppp*. The Percussion 1 part features a *tam-tam (M)* with instructions for playing on the center and edge, and a *quasi gliss.* section. The Percussion 2 part features a *tam-tam (L)* with instructions for playing on the rim and with a triangle beater. The Piano parts include instructions for playing on strings and across strings. The score concludes with a *rit.* section and a tempo change to *♩=c.35*.

Figure III-35: Pairing of tam-tams (acting as female & male) in Percussionists 1 and 2 in *Yuan-Liu*

Below are the pairings in the instruments of Percussionist 1 and Percussionist 2:

Percussionist 1:

Pos. I

- Suspend cymbal (M)
- Triangle (L)
- Tam-Tam (M)
- Pair of Chinese cymbal (Small size)
- 3 crotales:

A musical staff showing three notes on a treble clef, representing the pitches of the crotales for Percussionist 1, Position I.

[Prepare a double bass bow]

Pos. II (Solo)

- 2 Bongos
- Bass drum with natural skin
- 5 Woodblocks

Percussionist 2:

Pos. I

- Suspend cymbal (L)
- Triangle (M)
- Tam-Tam (L)
- Pair of Chinese cymbal (Small size)
- 3 crotales:

A musical staff showing three notes on a treble clef, representing the pitches of the crotales for Percussionist 2, Position I.

[Prepare a double bass bow]

Pos. II (Solo)

- One medium-large Dubachi (Japanese temple bowl bell) and crotales
- the drumhead of 23-inch timpano.
- 2 hanging metal plates (M/L)
- 3 Peking-gongs (tightly suspended on a frame)
- 2 slit drums (log drum)
- 1 glass bottle (filled with water)

A musical staff showing three notes on a treble clef, representing the pitches of the crotales for Percussionist 2, Position II.

both put on

Figure III-36: Pairings in the percussion instruments in *Yuan-Liu*

Among percussion instruments, crotales are the only one having equal temperament pitches that can be associated with other musical instruments. By contrast, the sounds produced by the other percussions are out of the equal temperament scale. The combined use of crotales and other percussions creates a compound acoustic space that is familiar at times yet strange at other times. The simultaneous use of notes in and notes out of an equal temperament scale breaks the underlying symmetry of music.

Figure III-37: Bars 11–15, crotales passages for Percussionist 1 in *Yuan-Liu*

Figure III-38: Bars 137–141, crotales passages for Percussionist 2 in *Yuan-Liu*

The tuning of the sheng remains relatively open in *Yuan-Liu*. The basic tuning of the sheng is $a = 442$ hz in an equal temperament scale. However, I do not require the sheng to be tuned and accord with the piano on the basis of equal temperament. Nevertheless, both the sheng and piano adopt the following core intervals (i.e., perfect 4th and 5th and major 2nd) in the pitches used in the work to create internal structural unity.

Figure III-39: Bars 1–5, pitches for the sheng part

Figure III-40: Bars 6–10, pitches for Piano 1

Figure III-41: Bars 1-5, pitches for Piano 2

Figure III-42: Bars 27-31, pitches for Percussion 1

Figure III-43: Bars 85-89, pitches for Percussion 2

4. Use of vocalisation

In many of my compositions, I have included instructions for extended vocal techniques for instrumentalists. I frequently use grace notes (some of which span large intervals), trills that begin in slow tempo and subsequently accelerate, trills with various intervals, glissandi with various speeds, repeated notes and sustained notes with various speeds of vibrato. For me, these techniques provide important creative possibilities for tonal inflections, pitch bending, non-pitch aspiration, heightened speech, and articulations. As a matter of fact, vocalisation has great influence on my melodic writing for instruments as well. I'm glad that I have started to explore the unlimited potential of the human voice in my instrumental compositions!

For example, in my composition *Temple bell still ringing in my heart (2002)*, composed for singing violist, the imitation of the melodic line between voice and viola recalls the idea of "female" and "male" instruments. In the beginning of the piece, the violist sings a long, sustained B-natural with various ornamentations,

creating an initial character. Afterwards, the viola starts with a sustained, low C-natural, which is the second character that creates intermingling fluctuations with the previous character in the piece. I instructed the violist to do different types of vocalisations. For example, the violist has to execute melismatic singing with various written-out ornamentations, noise-like inhalations and exhalations. These vocalised aspects are the soul of this particular work. It does not only present the spiritual and musical extensions of the instrument, but also brings out a sense of “soulfulness” in the music.

All of these elements are culturally significant in my compositions. The voice in this little piece is treated in a novel way by being associated with rituals in temple ceremonies, and primitive forms of expression such as folklore chanting. The use of a poem, text or vocalisation in a piece of music inevitably inscribes a composition with ethnic identity, as the use of vocalisation is common to various Asian traditions. For instance, the Korean Pansori⁹ singer, the Javanese rebab¹⁰ player and the Chinese folklore storyteller all play and sing as part of a story-telling and ritual ceremony. In this work, all these vocal elements are part of what I consider transcultural and “inner-cultural” elements of the music.

Lamento di lontano

♩ = c.40

Figure III-44: Opening section of *Temple bell still ringing in my heart* for viola solo (2002)

⁹ “Pansori is a one-man operatic form accompanied by a puk (double headed barrel drum). The singer executes all three elements: aniri (dialogue and narration), pallim (acting) and sori (singing)” (“Korea, 9-Folk music, Pansori,” 1980, p. 207).

¹⁰ “Javanese, Cirebonese, Balinese, and Sundanese two-string bowed string instrument with two brass strings and a skin-covered resonator” (Spiller, 2004, p. 284).

In *Yuan-Liu*, the sheng player has to both sing and play in several passages. Concurrently, the other musicians are required to do the same in order to create different types of singing gestures and imitations. See examples below:

Figure III-45: Bars 22–36, vocalisation between the sheng and Percussionist 2

Figure III-46: Bars 27–31, vocalisation among the sheng, Piano 1, and Piano 2

5. Teacher-student mentorship in the study of music: Interplay and interchange of roles

In many Asian music cultures, traditional music study is conducted through oral tradition, where a student studies closely with his or her teacher to master their musical techniques. Imitation and memorisation are very important within this practice, and the consistent interplay between the student and teacher often has an influence on the student's musical approach. At the end of this apprenticeship, the student must use this knowledge to create his or her own musical voice.

I would like to enforce the importance of this consistent interplay of roles between student and teacher. In *Wu Yan*, I fully notated the three solo passages with different ornamentation symbols, so that each pair of percussionists can have their very own interpretation to perform the same notated music. Another important aspect of this composition is the insertion of three solo positions to be shared by each pair of musicians. For example, Percussionists 3 and 4 will walk to Position I to play the same notated cadenza-like passage. Similarly, Percussionists 1 and 6 will walk to Position II to play the same notated cadenza-like passage. However, in the middle of the piece (which I designated as the water's double-mirror axis in this piece), Percussionists 2 and 5 play a different solo passage with a different instrumentation. Following this design, the similarity of musical sounds may appear in different positions of the stage, resulting in spatial effects for related materials.

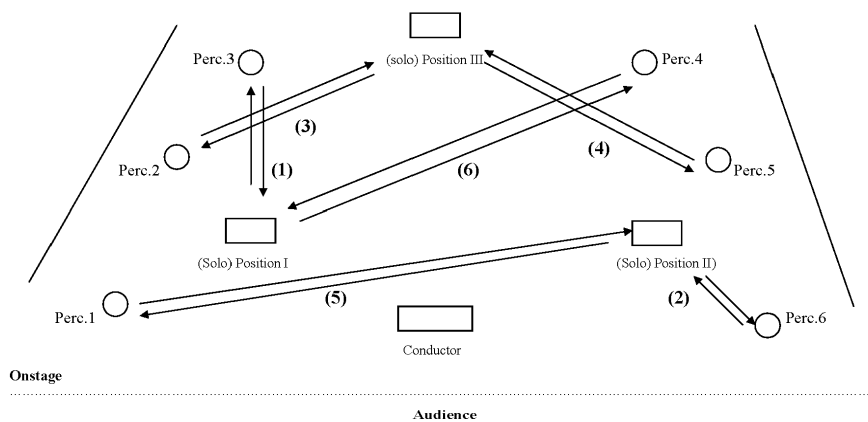

Figure III-47: Instrumental setup and mobility to three solo positions of *Wu Yan*

In *Yuan-Liu*, the piano and the percussion group always form an echo-like interplay and interchange of roles in the piece. Examples are as follows:

Figure III-48: Bars 22–26, imitation between Pianos 1 and 2 and also between Percussionist 2 and the sheng in bar 24

Figure III-49: Bars 122–126, imitation and interplay between Pianos 1 and 2 and also between Percussionist 1 and the sheng in bar 124

Another predominant concept in this work is the interchanging roles between Pianos I and II as well as Percussion I and II in the recapitulation section. When comparing bars 1–5 (Fig. III-50) with bars 127–131 (Fig. III-51) and bars 16–21 (Fig. III-52) with bars 116–121 (Fig. III-53), we find both pairs of players interchange their roles. Nevertheless, the sheng player still plays the same part as in the original section.

Tempo rubato $\text{♩} = c.35$

Sheng *Pos. I* *enter softly ppp* *accel.* *rit.* "Bao Huashe" $(\text{♩} = c.35)$ *mp* *sfz* *ppp* *mp*

Percussion 1 *Pos. I* *tam-tam (M)* *center* *edge* *center* *edge* *1.v* *scratch quickly (sharp accent)* *sfz p* *quasi gliss.* *sfz p* *come sopra* *center* *edge* *sfz p*

Piano 1 *gliss across strings* *on string(s)* *p* *mf* *gliss across strings* *on string(s)* *pp* *mp* *PI*

Piano 2 *sfz secco*

Percussion 2 *Pos. I* *tam-tam (L)* *hand (knuckle)* *triangle beater on the rim* *1.v* *scratch quickly (sharp accent)* *mp* *ppp* *come sopra* *on the rim* *mp*

Figure III-50: Bars 1-5, original section of *Yuan-Liu*

L *Tempo rubato* $\text{♩} = c.35$

Sh. *ppp* *enter softly ppp* *accel.* *rit.* "Bao Huashe" $(\text{♩} = c.35)$ *mp* *sfz* *ppp* *mp*

Perc. 1 *tam-tam (L)* *hand (knuckle)* *triangle beater on the rim* *1.v* *scratch quickly (sharp accent)* *mp* *ppp* *come sopra* *on the rim* *sfz* *mp*

Pno. 1 *gliss across strings* *on string(s)* *p* *mf* *gliss across strings* *on string(s)* *pp* *mp* *PI*

Pno. 2 *sfz secco*

Perc. 2 *tam-tam (M)* *center* *edge* *center* *edge* *1.v* *scratch quickly (sharp accent)* *sfz p* *quasi gliss.* *sfz p* *come sopra* *center* *edge* *sfz p*

Figure III-51: Bars 127-131, recapitulation section of *Yuan-Liu*

6. Transformation of the standard instrumental setup to a more complex spatialisation in order to create greater sonic mobility in my compositions

In 2005, I met the world-leading sheng virtuoso Wei Wu and his musicians from the Dragon Ensemble from Berlin. Inspired by his work, I started to compose my first piece that integrates both eastern and western instruments, *Metamorphosis VI-Wind player* (2005). It was my first cross-cultural work for traditional Asian and Western instruments. This composition is scored for traditional 37-reed soprano sheng, pipa, gu zheng and 10 Western instruments.

Since then I have composed many pieces for Wei Wu and his musicians, including *Endless whispering* (2006) for sheng (doubling xun) and 4 Western instruments (flute, oboe, clarinet in Bb and tuba) with live electronics; *Horizon's chant* (2007) for sheng, gayageum and koto; *Shui.Mo* (Water. Ink; 2008) concerto for 4 Chinese instruments (sheng, pipa, er hu and gu zheng) and Western symphony orchestra; *Phoenix calling* (2008) concerto for sheng and Western ensemble, *Yuan-Liu* (Origin-Stream; 2009) for sheng, 2 pianos and 2 percussionists and *Yuan-He* (Origin-Harmony; 2010) concerto for 5 Chinese instruments (sheng, dizi/guan zi, er hu, yang qin and gu zheng) and 5 Western instruments (flute, clarinet in Bb/bass clarinet, violin, cello and piano).

In July 2005, during my stay in Lyo Island, a little island in Denmark, I rewrote and re-conceptualised ideas from my piece *I hear the wind calling* originally for Western instrumental ensemble. The result is more than just a variation--it is a sublimation of the same musical ideas and it portrays the same emotions as the previous composition.

For a long time, I have been interested in Tang dynasty culture. This has prompted me to experiment with the abstract form of “qi” (air, 氣)¹¹ in Chinese calligraphy and ink painting; “qi” represents the image of wind in this composition.

In *Metamorphosis VI-Wind prayer*, I focused on the traditional and extended timbral resources of both Eastern and Western instruments. With this approach, I was able to create a range of abstract sounds to evoke the abstract form of “qi” (air, 氣) which is the intermingling fluctuation between these two different cultural worlds.

I create a confluence of sounds in the timbres of Eastern and Western instruments in *Metamorphosis VI-Wind prayer*. In the performance, the flute, clarinet, and sheng seated around the audience form a wind-like mobility of sound. One can hear the wind's “soundscape” from different directions and the depth of this new sonic world inside the concert space. In this work, I was able to maintain a semblance of traditional Asian musical writing while creating a

¹¹ Qi literally means air or breath in Chinese. This concept denotes “the circulating life force whose existence and properties are the basis of much Chinese philosophy and medicine” (“Chi”).

realisation that was technically and culturally suited to the Western manner of performance practice.

Below is the instrumental setup of the piece:

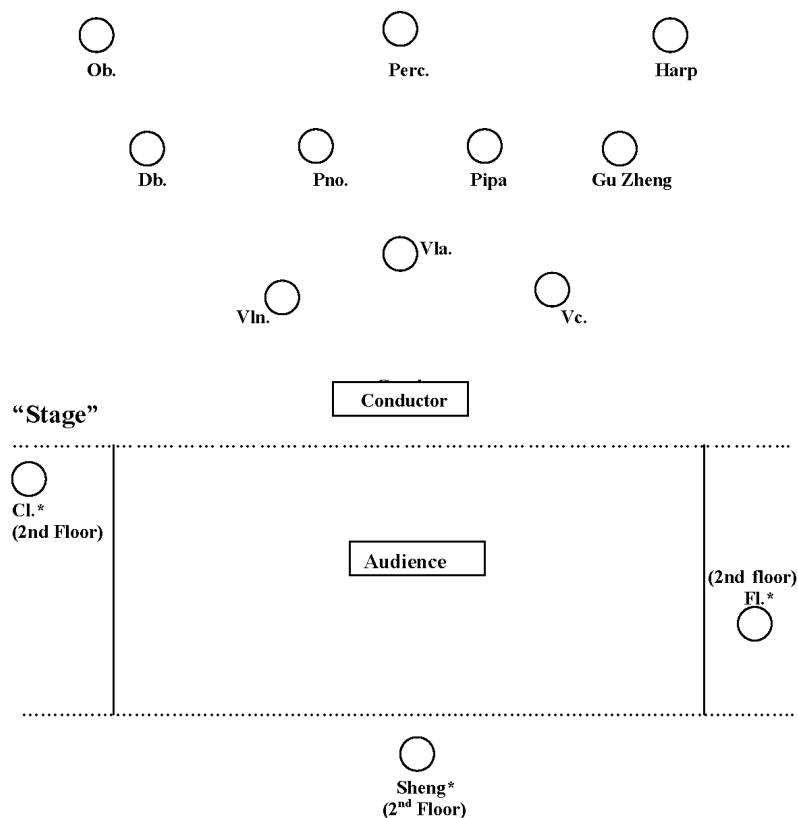

Figure III-54: Instrumental setup of *Metamorphosis VI-Wind prayer*

Score examples on the following two pages provide an idea of the use of traditional and extended timbral resources of both Eastern and Western instruments.

In Figure III-55 and Figure III-56, the unique playing techniques of three traditional Chinese musical instruments are employed and integrated into the complex acoustics produced by Western instruments. The unique techniques include the pipa's rolled tremolo glissandi in bar 25 as well as the long tremolo and the player's mantra-like murmuring in bar 30; the gu zheng's drastic sforzando plucking in bar 28 and the long improvised vibratos that start from bar 26 and extend to bar 28 where the player performs increasingly loud and low glissandi by the left hand; and the sheng's peculiar high-pitched gliding techniques in bar 26 and traditional perfect 4th harmonisation in bar 27.

As for Western instruments, I adopted a relatively complex acoustic design. For example, the long chanting tones played by the oboe in different rhythms on the stage are combined with similar tones produced by the flute, clarinet, and traditional sheng around the audience. Concurrently, the members of the string ensemble on the stage apply special artificial overtones one after another in bars

25–28, then welcoming the climax in bar 29. The ostinatos performed by percussionists with their hands on the drum and bass gong correspond to the tremolo glissandi and vocalised ostinatos of the pipa part. In bar 26, the harp and piano produce short forte chords at an extremely high register to support the oboe on the stage and the flute, clarinet, and sheng around the audience.

molto accel. $\text{♩} = c.84$ *A tempo* $\text{♩} = c.42$

*sing the indicated diamond-shape note head with continuously articulate the indicated vowels to obtain a modification of timbre of the singing.
(Male player should sing one octave lower!)

Figure III-55: Bars 25–27 of *Metamorphosis VI-Wind prayer*

molto accel. ca. 12" *Senza misura* *Tempo rubato* ♩ = c.35 D *Impassivo* ♩ = c.42

The score is divided into several systems. The top system includes Oboe, Pipa, Percussion, and Double Bass. The middle system includes Harp, Guitar, and Piano. The bottom system includes Violin, Viola, Violoncello, Flute, Bass Clarinet, and Soprano Saxophone.

Key performance instructions include:

- Pipa:** *ppp* sempre (very evenly), voice in the lowest register, *ppp ~ mp* murmuring like incantation (whisper-like), continue in this register & manner ad lib.
- Perc.** sleigh bells (Hit gently the sleigh bells (LH) with right hand), 2 bending gongs (different size) with soft yarn mallets, *ppp* dolciss., *ppp*, *p* pochiss., *ppp*.
- Piano:** Rubato gliss. over strings with fingers, *pp*, *sfz*, wide & slow vibrato, gliss., Voice: *p*, *mf*, *pp* very passion!, *PI*, *PIII* (U.C.) sempre.
- Violins/VIAs/Vcs:** (gradually m.v.) *pp* *molto* *f* *e.s.p.*
- Flute:** *ppp*, *pp*, *pp*.
- Soprano Saxophone:** enter softly *ppp* sereno, *pp*, *mp*, *mf* espr., *p*, *sfz* sub, *pp*, *mp*.

Figure III-56: Bars 28–32 of *Metamorphosis VI-Wind prayer*

Many contemporary composers such as Peter Eötvös, György Kurtág, Toru Takamitsu, José Maceda, and Toshio Hosokawa have integrated the idea of spatialisation in their compositions. This concept fascinates me and has a great influence on my music.

As mentioned previously, my upbringing left a mark on my artistic outlook, and I listen to the sounds of nature for inspiration. From 2004, I started to explore the idea of spatialisation. I rearranged the seating positions of my musicians at the performance venue to re-create the experience of listening in nature.

In addition to my fascination with the multi-dimensional sounds in Nature, I have accumulated multiple acoustic experiences after having attended various contemporary concerts in Europe for years. Particularly, in the Brussels Ars Musica Festival in 1998, I encountered *Gruppen*, a multi-dimensional acoustic work composed by Karlheinz Stockhausen for three orchestras and three conductors. This work offered me the most immersive acoustic experience. *Gruppen* was performed by Ensemble Intercontemporain and Paris Conservatory Orchestra under the batons of three great conductors Pierre Boulez, Peter Eötvös, and David Robertson at the Halles de Schaerbeek in Brussels. The audience was surrounded by three orchestras. Sound shifted from one orchestra to another. Specifically, the brass passage in rehearsal mark 119 in the middle of the work was sequentially played by the three orchestras, creating like a swirl-like soundscape that enlightens me about the possibilities of multi-dimensional acoustics. Please refer to this brass passage:

Score reproduced from *Gruppen* by Stockhausen, copyrighted by Universal Edition

Orchestra I (Left) Brass
Orchestra II (Center) Brass
Orchestra III (Right) Brass

Rehearsal mark 119, tempo marking ♩ = 120.

Figure III-57: Score reproduced from *Gruppen* by Stockhausen, copyrighted by Universal Edition

In most of my compositions, I have rearranged the instrumental setup in the concert hall. Another example is my *Endless whispering* (Figure III-58). Similarly, I focused on the subtle intimacy of the mobility between the instruments on stage in *Yuan-Liu* (Figure III-59). I set up five performing positions for the sheng surrounding the two pianos and two percussionists. These five different positions represent the idea of the Wu Xing, and each movement represents a mutually generating or overcoming process in this work.

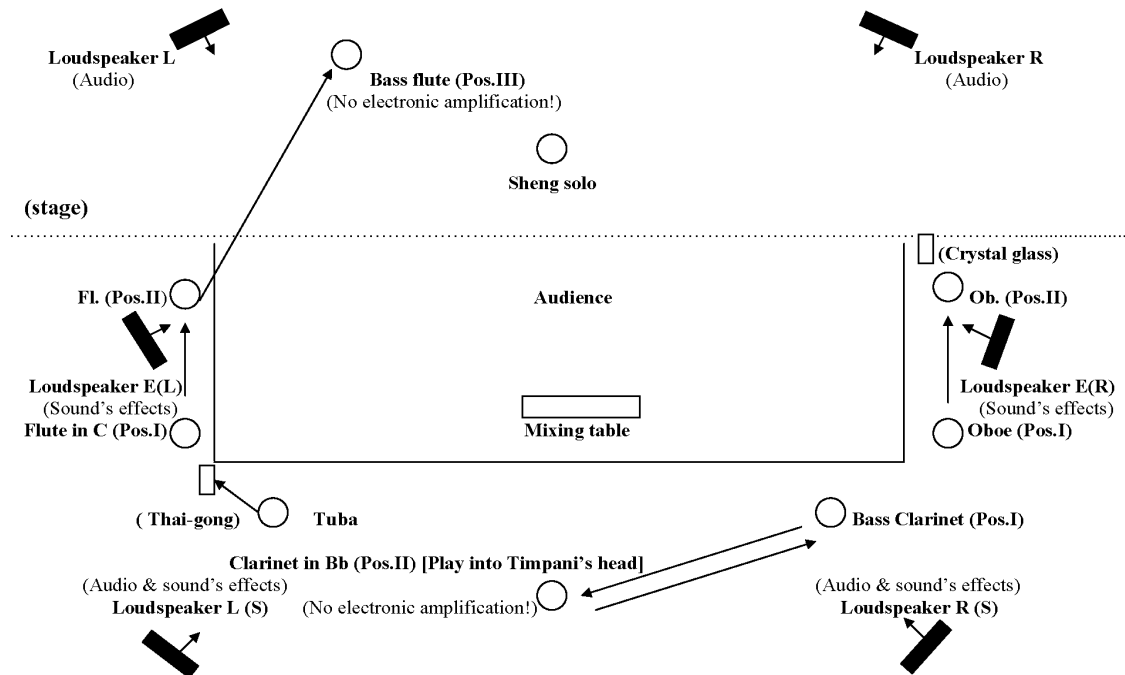

Figure III-58: Instrumental setup of *Endless whispering*

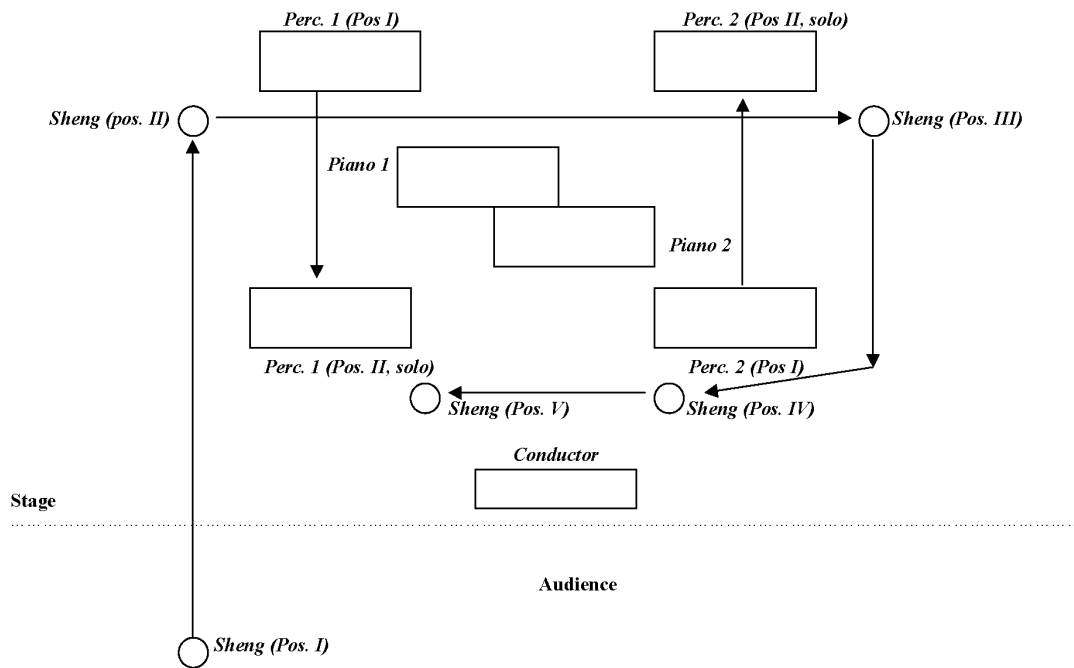

Figure III-59: Instrumental setup of *Yuan-Liu*

Chapter IV. Conclusion

The compositions in this thesis illustrate the development of my works over the past decade and present a diversity of styles and expressions informed specifically by Chinese and Malaysian cultures. This diversity stems from a desire to create music that assimilates the cultural influences I have been exposed to. As a Malaysian composer and researcher of various Asian traditional forms, I strongly believe in the importance of continuing to study and preserve Asian musical heritage whilst also embracing new creative expressions for these traditions within a modern multiculturalism.

I learn living traditions from masters of the last generation, develop the awareness of and respect for cultures and arts, and finally employ these elements to compose works that are both traditional and innovative. Many of my compositions such as *Bie Ge* (2012), *Xun Feng* (2013), and *Timeless echoes* (2010/2011) highlight the features of singing and the narrative forms of traditional Asian music. My music reflects the East Asian aesthetic ideal that art should be a cross-disciplinary form incorporating language and its intonations, poetic image, music, and the visual arts. A key example of this is my work *Timeless echoes* with its story-telling narrative and references to a Chinese aesthetics of spiritual transcendence.

In most of my compositions, I insert *senza misura* passages and fermatas of different lengths in the context of strict Western notation to break its usual mechanical precision, enabling performers to improvise intuitively, and thus create a sense of time and natural flow unique to Eastern music.

In the third chapter, I discussed temporal characteristics in the music of East Asia. Particularly, the use of single tones in Asian classical court and temple music traditions has been recognised and examined by prominent Asian composers Isang Yun and Wen Chung Chou.

Yü Ko or *Fisherman's Song* is one of Chou's most important works that highlight the single-tone principle. Based on an ancient qin melody titled "fisherman's song," this work focuses on giving life to each single tone with amplified inflection in pitch, articulation, timbre, dynamics, and rhythm.

My own compositions have benefited greatly from the single-tone aesthetics proposed by Yun and Chou. Different categories of temporality exist in the world of single tones. Although a musical piece may consist of a series of single-tone elements, each "tone" is a piece by itself and represents its own temporal space in a larger temporal cosmos. In one of my works *Liu-Xu-Fei* (2001), the use of single tones extends to create heterophony and living ornamentation that develops its own temporal space (examples in Chapter III).

José Maceda, a Filipino composer and ethnomusicologist specialising in Southeast Asian village music, wrote a seminal article "A Concept of Time in a Music of Southeast Asia." (1986) In the essay, Maceda focused on the drone and

repeating melodies in the music of Southeast Asia, arguing that these elements represent a concept of infinity, timelessness and equilibrium. Ramón Pagayon Santos supports Maceda's argument by further elaborating that this aesthetics of drone and repeating melody is realised through "the qualities of sound, colors, decays, repetition, unmetered time (absence of strong and weak beats), the absence of prescribed introduction and ending, and its interdependence with other expressive elements such as bodily movements and the environment."¹ This association of drone and repetition with infinite temporality, as well as the consideration of space and performers' bodily expressions, have inspired me to experiment with time and spatialisation and introduce Southeast Asian elements in my compositions.

According to Santos, this concept of time is also manifested by the various families of instruments in Javanese gamelan music. In the "Colotomic" structure of the music, each instrumental group serves a specific and temporal function, producing a characteristic timbre and resonance. In both *Bie Ge* and *Xun Feng*, I integrated the aforementioned concepts of time and space to create a drone-like gong circle, and each instrument has its own characteristic timbre and resonance. My employment of these concepts in the two works is elaborated in Chapter II.

I am interested in how music can be influenced by the new East–West aesthetics in multi-layered cultural and ethnic heritages. My works *Metamorphosis VI-Wind prayer* (2005), *Endless whispering* (2006), *Shui.Mo* (2008), *Yuan-Liu* (2009), *Yuan-He* (2010), and *Phoenix calling* (2013) are my response to this concept of cultural confluence. I believe that those works carry both the Asian and Western legacies and will continue to recreate cultural dynamics and multi-faceted interactions in their encounters with performing groups of different origins.

Through my journey from my early compositional approach towards a new East–West aesthetics of today, I believe that the future of the arts will depend on continuous preservation and study of our traditional cultural heritages. We should encourage multicultural musical performing art forms among artists, and at the same time enhance the intrinsic understanding of what constitutes multicultural and multi-disciplinary exchange between musicians and audiences. I also strongly believe in Prof. Chou's idea of "confluence" and "re-merger" of legacies. As he stated, we are "coming together, sharing each other's heritage, complementing and revitalizing legacies."

Working with great Chinese and Western musicians from these two diverse disciplines has been a source of great inspiration. I have benefited from and learnt the value of developing strong relationships with the musicians I write for, and to whom I have had the pleasure to dedicate these pieces. With their advice and trust, we have always pushed one another to attempt something new and innovative in my compositions. I strongly believe that composer and performer can share great respect, and excitement for new musical possibilities. Most of my compositions therefore have been deliberately scored for specific musicians.

¹ From Santo's lecture paper "A Concept of Time and Space in Asian Artistic Expression" presented at a summit on 10 June, 2016 during the China ASEAN Music Week (p. 2).

Collaborating with them has helped me to express my compositional philosophy and my approach to a new East-West aesthetics.

In the future, I will continue to express this diversity in my compositions and engage with my cultural heritage and artistic sensibility to bridge cultural territories of the East and the West.

In short, I hope my compositions can achieve the following outcomes:

- Create a new musical style that fuses both Eastern and Western musical materials.
- Encourage creativity and innovation founded on a thorough understanding of one's own heritage as well as a balanced adaptation of ideas from other cultures.
- Provide a fresh approach to the philosophical exchange between Eastern and Western cultures:
 - For composers to discover a new and varying range of individual expressions and to further seek new avenues and approaches.
 - For performers to experience a nuanced level in their approaches to Eastern/Western music and develop a heightened sensitivity to a new world of sound.
- On a broader perspective, that the bond between Eastern and Western music may lead to a common understanding between different cultures that paves a way for further collaboration between artists.

In my frequent exchanges with folk and traditional musicians or artists, I found that although most of them are not familiar with Western notation, they have exceptional hearing, perception, and performing skills. Therefore, I believe that as long as composers make good use of folk musicians' familiarity with traditional repertoire and notation, creating innovative notational or performing marks for them, an effective platform for collaboration will be established.

Lastly, I hope that in the near future I will have the opportunities to work with traditional musicians or artists who are not familiar with notated music. I would like to devise ways of working as a composer "beyond notation" and look for new notational methods that provide ways of signalling and communicating in a performance with the traditional musicians or artists. With this new and creative collaboration, I believe that both traditional musicians or artists and composers will contribute to the enrichment of special ways of playing, listening, and interacting in Asian performing arts.

Appendix A. Lecture paper: Inspiration from Chinese cultural sources and Western contemporary musical techniques in my compositional practices

By KEE YONG CHONG, composer (Malaysia)

Lecture at the “2013 Composition workshop for the Chinese instrumental ensemble” on 16th July 2013 at the National Centre for Traditional Arts (Yilan, Taiwan)

1. Introduction

Dear colleagues and friends, good afternoon.

It has been a pleasure to have discussion on many intriguing composition issues in the past few days with many composers, scholars, musicians, and teachers in this composition workshop for Chinese instrumental ensemble. I am very pleased to have a great opportunity to exchange comments with many young composers and the musicians of “Chai Found Music Workshop” (Taiwan) in this composition workshop on young composers’ compositions. I wish to thank the Taiwan Music Institute for their invitation and thoughtful arrangements to invite distinguished composition mentors Prof. De Ho Lai (Taiwan), Prof. Yi Chen (USA/China), and musicians of “Chai Found Music Workshop” as teaching faculty for this workshop.

In this chapter, I’d like to share my experience of how I work with my inspirations from the Eastern music within a Western contemporary musical context. I will talk more about the important role of Chinese traditional instruments and my long-time collaborator sheng player Mr. Wei Wu and gu zheng player Ms. Feng Xia Xu in a few of my musical compositions. I would also like to show the various facets of my writing for Chinese instruments, exploring specific techniques in detail as well as similar applications with other traditional musical instruments from Korea and Japan, and Western instruments.

From 1994 to 2004, I focused on the idea of integrating traditional Eastern aesthetics with Asian cultures whilst avoiding using any Eastern instrumentation in my early compositions but composing solely for Western instrumentation to study all its potentials. I wanted to have a different view from another perspective of the familiar sounds that I’m used to and grew up with while trying not to be “exotic” as an Asian composer in the Western musical world. In 2005, I was fortunate to meet three great Chinese virtuosos Wei Wu, Feng Xia Xu, and Xiao Fen Min in Amsterdam to work on my first composition that employed both Eastern and Western instruments: *Metamorphosis VI-Wind Prayer* (2005) for a 37-reed traditional soprano sheng, gu zheng, pipa and a Western ensemble consisting of 10 players. This composition was awarded as one of the winners at the Nieuw Ensemble’s “Young Chinese Composers Competition 2005”. I was deeply moved and inspired by their knowledge of contemporary music and

improvisational music. This knowledge is deeply rooted in their traditional repertoires and their excellent skills and experience of performing new music that is notated using complex scores for their instruments. It is very rare for a Chinese musician in the traditional field of study to perform pieces written in contemporary Western notation. Most importantly they understand my intention of inducing the best timbres from both Chinese and Western instruments and of grasping their personalities while integrating their characteristics to accomplish the ultimate aesthetics of *Metamorphosis VI-Wind Prayer*.

Since then, I have started to explore the sonic possibilities of traditional Chinese instruments in my compositions and worked closely with Mr. Wei Wu to continue composing many pieces for him and his Dragon ensemble (Berlin). These compositions include *Endless whispering* (2006) for sheng (also playing doubling xun, a Chinese ocarina) and four Western instruments (flute, oboe, B-flat clarinet and tuba) with live electronics; *Horizon's chant* (2007) for sheng, gayageum, and koto; *Shui.Mo* (Water.Ink; 2008) concerto for four Chinese instruments (sheng, pipa, er hu, and gu zheng) and a Western symphony orchestra; *Phoenix calling* (2008) concerto for sheng and Western ensemble, *Yuan-Liu* (Origin-Stream; 2009) for one sheng, two pianos and two percussions; and *Yuan-He* (Origin-Harmony; 2010) concerto for five Chinese instruments (sheng, dizi/guan zi, er hu, yang qin, and gu zheng) and five Western instruments (flute, B-flat clarinet/Bass clarinet, violin, cello, and piano).

2. *Metamorphosis VI-Wind prayer*

Metamorphosis VI-Wind prayer, written for 37-reed traditional soprano sheng (also playing portable radio player), pipa, gu zheng, flute (also playing Thai gong and portable radio player), oboe (also playing Thai gong), B-flat clarinet (also playing Thai gong and portable radio player), percussionist, harp, piano, violin, viola, cello, and double bass, is my first cross-cultural work for Chinese traditional instruments and Western instruments. In this piece, I aimed to create a new musical language that can be identified as the interaction between Eastern and Western musical materials and to achieve a confluence between the timbres of Eastern and Western instruments.

2.1. Instrumental setup and the soundscape of moving wind

My idea was to devise a “soundscape” of wind moving from different directions and depths that creates a new confluence of sounds within the concert space. I set up a special instrumental setup to imitate the mobility and sound of wind during the performance. I positioned the flute, clarinet, and sheng around the audience and designed a special seating arrangement for instruments on stage. This work preserves the semblance of traditional Asian musical writing while creating a realisation that is technically and culturally suited to the Western manner of performance practice. This composition saw the fruition of my explorations of the sonic possibilities of traditional Chinese instruments with Western ensembles.

The instrumental setup is as follows:

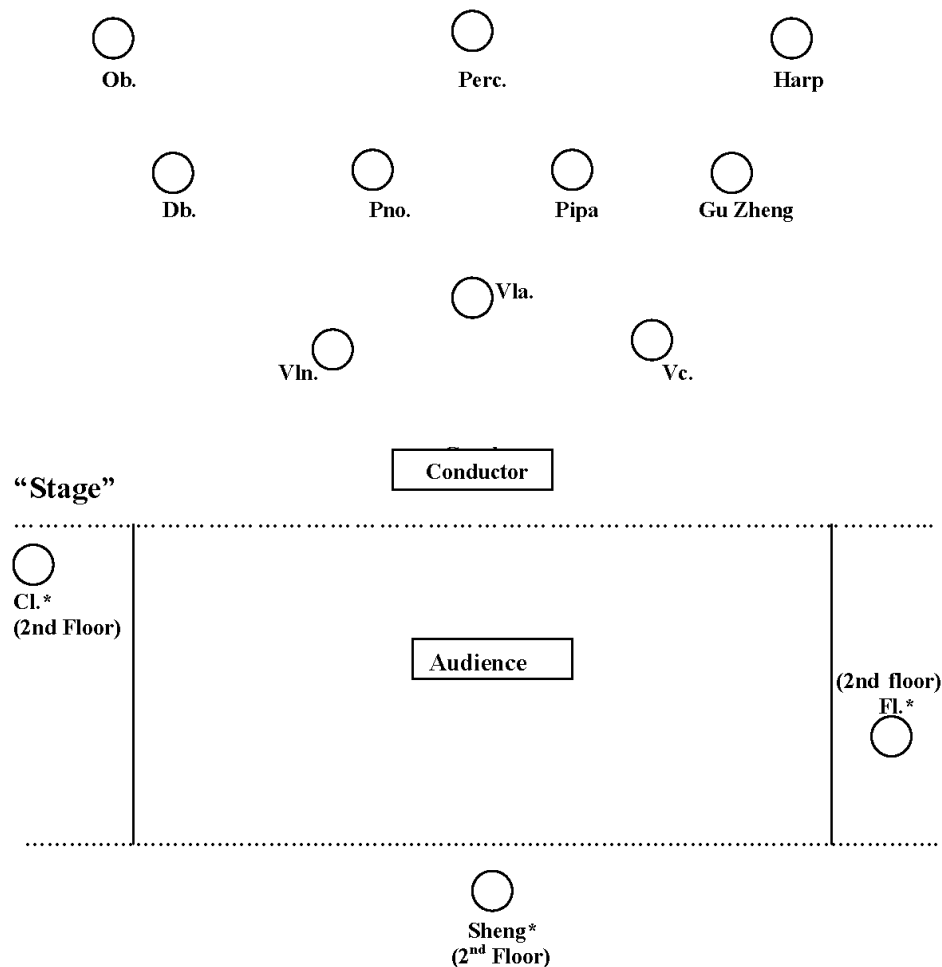

Figure A-1: Instrumental setup of *Metamorphosis VI-Wind prayer*

2.2. Use of the 37-reed soprano sheng

The traditional sheng, one of the oldest Chinese reed wind instruments, is a multi-reed mouth organ. The instrument's bamboo pipes, each of a different length, have been compared to a phoenix at rest with its wings closed. The sheng is a wind instrument, which uses the vibration of bronze reeds attached to bamboo reeds to create sound. The rich and dynamic sound qualities of the sheng make it a popular instrument in the Chinese orchestra. In Chinese folk music, it is common for the sheng to be used as accompaniment for dizi, guan zi, and suona.

Mr. Wei Wu, an avant-garde sheng soloist, has helped to develop this ancient instrument into an innovative force in contemporary music through the creation of new techniques while expanding its repertoire and integrating different styles and genres. In all my compositions that include both Eastern and Western instruments, I specifically adopted the 37-reed soprano sheng which was redesigned by Shanghai sheng maker Mr. Zhenfa Weng working with virtuoso Mr. Wei Wu.



Figure A-2: Mr. Wei Wu and his 37-reed soprano sheng (photo provided by Wei Wu)

Mr. Wei Wu introduced me to the great possibilities and multi-faceted nature of the redesigned traditional 37-reed soprano sheng. This instrument incorporates all the playing possibilities of the traditional Chinese sheng, Japanese 17-reed sho, and Korean 24-reed saenghwang, but is at the same time more powerful and flexible with extended techniques. Unlike its Korean and Japanese counterparts, the Chinese traditional sheng has a history of more than 4,000 years and has been developed and modernised into a highly versatile instrument. As it retains the traditional open holes and is given a new key mechanism, the instrument has the potential for chromaticism, microtones, chords, polyphony, clusters, and many other techniques for contemporary music. The sheng is capable of producing the eeriest of sounds and can also be played with explosive power.

The fingering chart and range of 37-reed soprano sheng redesigned by the Shanghai sheng maker Mr. Zhenfa Weng are as follows:

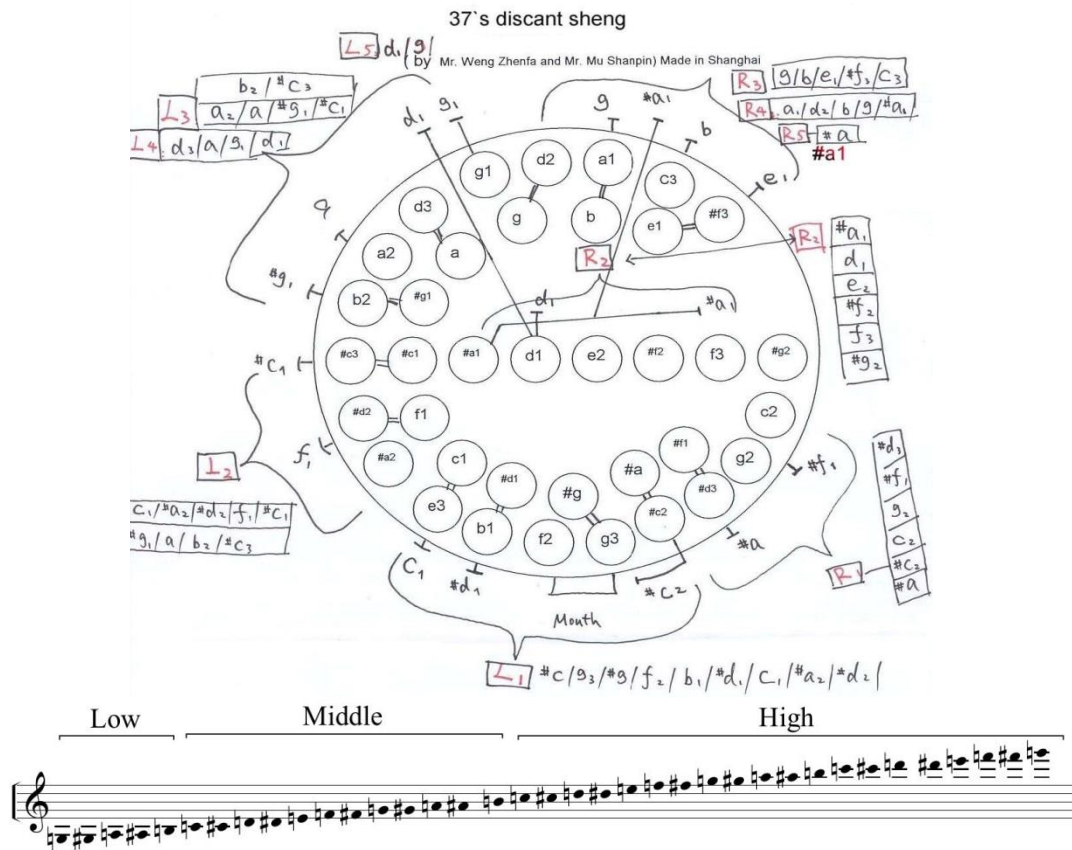



Figure A-4: Ms. Feng Xia Xu and her 21-string gu zheng (photo provided by Feng Xia Xu)

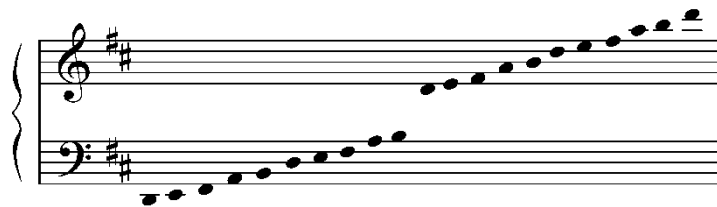

Figure A-5: 21-string gu zheng's tuning for *Metamorphosis VI-Wind prayer*

2.3.1. Bowing techniques of the gu zheng

The bowing is actually derived from the playing techniques of an instrument called yazheng in the ancient court music of Tang dynasty. According to *Jiu Tangshu* (舊唐書, Old Tang History), Yazheng is designed to make creaking sound (軋, *ya*) using a tip-moistened slip of bamboo (Turnbull, 1981, p. 197). Yazheng is the earliest archetypal string instrument in the history of Chinese music. Although yazheng is categorised as a variation of the plucked instrument gu zheng in *Jiu Tangshu*, mainly because of its zheng-like shape and structure (Fig. A-6), this ancient string instrument is bowed rather than plucked.¹ In Korean court music, the bowing techniques are still practiced on a similar instrument called the ajaeng (i.e., a large 7-string zither). Ajaeng is a large 7-string zither that “first came from China and used only in court music (Lee, 2015, p. 149).

¹ See the introduction of “10. Guoyue huqin” [national instrument er hu] from a Webpage titled “Collection of cultural relics: Others” under the Art Cultural Research Center of Nanhua University (URL access: http://art2.nhu.edu.tw/page1/super_pages.php?ID=page101&Sn=5)



Figure A-6: A folk music musician playing the yuzheng (Photo from an online resource)²



Figure A-7: Ms. Hwayeon Lee, first chair of Ajeang of the Contemporary Gugak Orchestra, National Gugak Center, demonstrated bowing techniques on Ajeang in the 2015 Gugak International GUGAK Workshop on 23 June 2015. (Photo credited by Kee Yong Chong)



Figure A-8: Feng Xia Xu used bowing techniques on the gu zheng in the dress rehearsal with the Singapore Chinese Orchestra for “Hak.Qin” composed by Kee Yong Chong (Photo credited by Kee Yong Chong)

² URL access to the photo: Cultural China, <http://arts.cultural-china.com/en/94Arts13879.html>.

2.3.2. Examples of bowing techniques applied in *Shui.Mo* and *Yuan-He*

The following are various types of gu zheng's bowing techniques I employed in my *Shui.Mo* (Water. Ink; 2008) concerto for four Chinese instruments (sheng, pipa, er hu, and gu zheng) and Western symphony orchestra, and *Yuan-He* (Origin-Harmony; 2010) concerto for five Chinese instruments and five Western instruments:

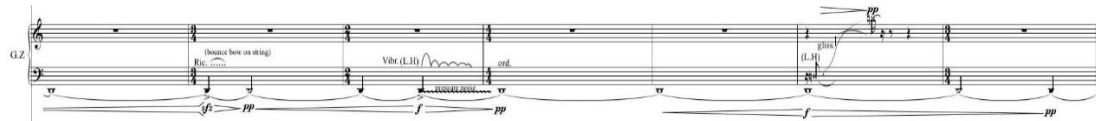

Figure A-9: Bow bouncing on string; left hand pressing to produce vibrato while bowing; left hand gliding on the left side of the instrument (bars 34–40 in the first movement, gu zheng part of *Shui.Mo*)

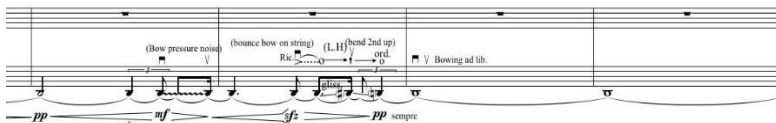

Figure A-10: Left hand pressing the lowest string to produce different types of pitch bending (bars 44–47 in the first movement, gu zheng part of *Shui.Mo*)

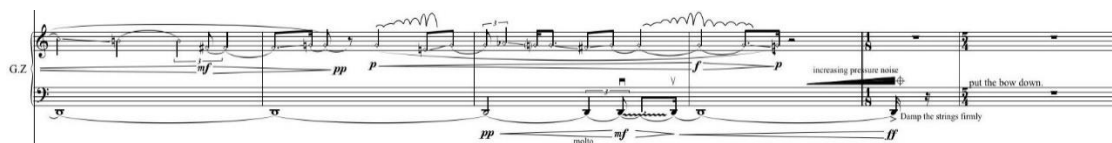

Figure A-11: Singing the notated melody while bowing with strong bow pressure (bars 55–60 in the first movement, gu zheng part of *Shui.Mo*)



Figure A-12: Left hand plucking the normal right side of the strings as improvisation while bowing; left hand gliding on the left side of the instrument (bars 59–63 in the second movement, gu zheng part of *Shui.Mo*)

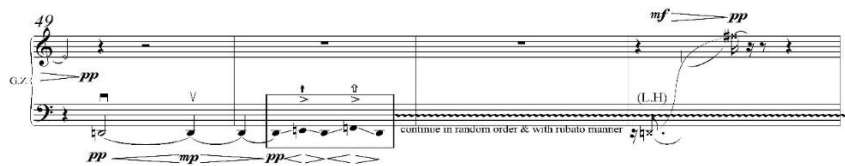

Figure A-13: Bowing the lowest string with left hand, pressing the string to produce different types of pitch bending; continuing the pitch-bending improvisation randomly; left hand gliding on the left side of the instrument (bars 49–52, gu zheng part of *Yuan-He*)

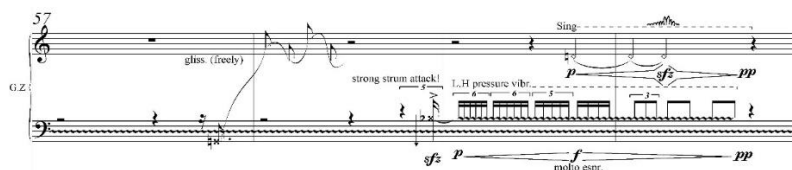

Figure A-14: Left hand gliding and strumming the left side of the instrument, then using left hand to press the lowest string to produce vibrato-like pitch bending according to the notated rhythmic pattern (bars 49–52, gu zheng part of *Yuan-He*)

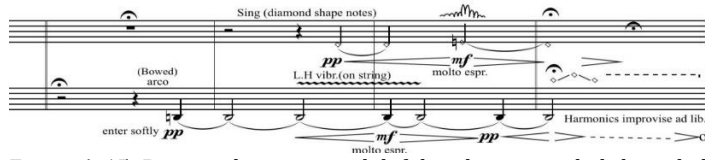

Figure A-15: Bowing the string with left hand, pressing lightly and gliding to produce the harmonic sweeping sounds (bars 105–108, gu zheng part of *Yuan-He*)

2.4. Integration of the sheng, gu zheng, and pipa

The following examples demonstrate how I integrate the sheng, gu zheng, and pipa in *Metamorphosis VI-Wind prayer*:

(a) In this piece, I often use the gu zheng’s mixing timbres produced from two type of glissandi: the glissandi on the right side of the instrument and the unpitched glissandi on the left side (over the bridge). These types of playing techniques are common in the solo repertoire of the contemporary gu zheng, where the two types of glissandi are combined to create dramatic tension and provide otherworldly timbral and psychological sensation for the composition.

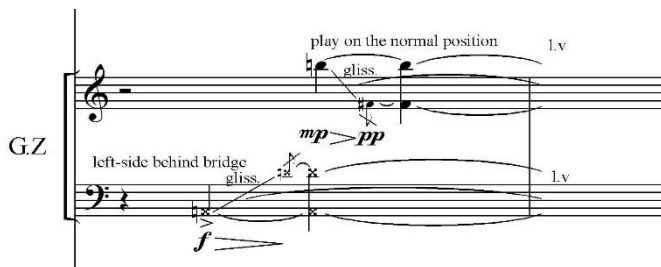

Figure A-16: Bar 5, gu zheng part of *Metamorphosis VI-Wind prayer*

(b) Strong attacks on lower strings are adopted to create gu zheng’s most characteristic bending of one semitone up (i.e., portamento).

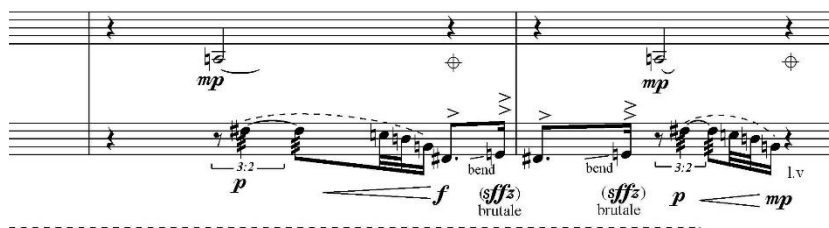

Figure A-17: Bars 11–12, gu zheng part of *Metamorphosis VI-Wind prayer*

(c) The traditional techniques of tone bending in the pipa and gu zheng are combined with the glissandi created on the piano’s strings, the harp, and the bass drum.

Figure A-18: Bars 13–15, pipa, gu zheng, bass drum, harp, and piano parts of *Metamorphosis VI-Wind prayer*

(d) The pipa’s characteristic playing technique of full tremolo 滚 “gun” on all four strings is mixed with other complex sound timbres, such as multiphonics on the oboe. This combination creates a new texture of merging sounds.

Figure A-19: Bars 9–12, pipa, oboe, and percussion parts of *Metamorphosis VI-Wind prayer*

(e) The sheng’s long chord sounds are mixed with the clarinet’s tone-variation on the single B-natural to create a fluctuation of sustained pitches. The sheng and clarinet are positioned offstage. When listened from a distance, this combination of inflected pitches produces a poetic sense and listening experience for the audience sitting in the middle of the concert venue.

The score for bars 9-12 shows three staves. The Flute staff (Fl.) begins with a glissando and a *pp* dynamic. The B♭ Clarinet staff (B♭ Cl.) starts with a *pp* dynamic and includes markings for 'enter softly', 'sub', 'Tone-colour var.', and various dynamics like *sf*, *mp*, *sf*, *mp*, *sf*, *pp*, *f*, and *pp*. The Sheng staff (S. sh.) features dynamics such as *p*, *sf*, *f*, *molto*, *sf*, *f*, *molto*, *sf*, and *pp*.

Figure A-20: Bars 9–12, three offstage instruments flute, clarinet, and sheng parts of *Metamorphosis VI-Wind prayer*-

(f) Another similar combination of techniques involves employing the sheng’s bending tones³ with the clarinet’s bending tones to create complex pitch fluctuations that resemble ornamental vibratos in Chinese traditional music.

The score for bars 13-15 shows three staves. The Flute staff (Fl.) includes markings for '(undefined high pitch)', 'Vibr. speed', 'flutt.', and 'ad lib. internal trills'. The B♭ Clarinet staff (B♭ Cl.) features 'gliss.', 'slowly gliss.', 'S.V.', 'M.V.', and '(different)'. The Sheng staff (S. sh.) includes '(Bending?) (fluctate vibr)'. Dynamics range from *sf*, *p*, *pp*, *sf*, *pp*, *f*, *molto*, *f*, *molto*, *pp*, *mp*, and *f*.

Figure A-21: Bars 13–15, three offstage instruments flute, clarinet, and sheng parts of *Metamorphosis VI-Wind prayer*

³ The traditional soprano sheng’s bending pitches are only available in the register of a^2-g^3 .

(g) The gu zheng ends abruptly with a very short accent and several brutal “improvisational” pitches to imitate the small Chinese Peking single drumhead drum (Ban gu, 板鼓) and gives the cue to the pipa’s vocalisation in the “sing & play” section.

The image shows a musical score for Figure A-22, covering bars 25-27. It features six staves: Oboe (Ob.), Pipa, Percussion (Perc.), Double Bass (D.b.), Harp (Hp.), and Gu Zheng (G.z.). The Oboe part starts at bar 25 with a 'slow gliss.' and 'ppp' dynamic, followed by 'mf' and 'molto accel.' markings. The Pipa part includes 'slow gliss.', 'pp (actou.)', and 'sfz' markings. The Percussion part features 'mf', 'p', 'pp', and 'mp' dynamics, with specific instructions like '(Palm of L.H.)' and 'large gong in C'. The Double Bass part has 'pp' and 'p' dynamics. The Harp part is mostly silent with some 'ff' markings. The Gu Zheng part includes 'continue', '(improv.)', 'brutale', and 'pp' markings. The score is marked with 'molto accel.' and 'A tempo' with a tempo of quarter note = c.84. There are also 'vibr. speed' and 'vibr. (irregular)' markings.

Figure A-22: Bars 25–27, oboe, pipa, percussion, double bass, harp, and gu zheng parts of *Metamorphosis VI-Wind prayer*

3. Endless whispering

After my first attempt to integrate Eastern and Western instruments in *Metamorphosis VI-Wind prayer*, I decided to work closely with sheng player Mr. Wei Wu to learn more about the instrument. When I received a commission from the Akademie der Kunst (Berlin) for my Junge Akademie fellowship in late 2005, I proposed to invite Mr. Wei Wu as a featured soloist to play with KNM Berlin’s Ganesha and live electronic music assistant Mr. Andre Bartetzki.

The resulting piece was *Endless whispering* (2006) for 37-reed traditional soprano sheng (also playing xun), flute (doubling on bass flute), B-flat clarinet (doubling on bass clarinet), oboe (doubling on crystal wine glass), tuba (doubling on Thai gong), and live electronics. In this work, I intended to present the up-to-date and diverse techniques of 37-reed soprano sheng along with the compositional concept of spatialisation of different instruments and live electronics around the concert venue.

3.1. Instrumental setup

The instrumentation and instrumental setup of *Endless whispering* is as follows:

Center-onstage:

Sheng solo (37-reed soprano sheng), doubling on Xun

Left side [middle]:

Flute in C (doubling on bass Flute)

- Pos.I: Flute in C (offstage)
- Pos. II: Flute in C (offstage)
- Pos.III: bass Flute (onstage)

Right side [middle]:

Oboe (also play crystals glass) 

- Pos. I: Oboe (offstage)
- Pos. II: Oboe (offstage)

Left side-offstage [back]:

Tuba (doubling on Thai gong) 
(offstage)

Right side-offstage [back]:

Clarinet in Bb (doubling on bass Clarinet)

- Pos.I: bass Clarinet (off stage)
- Pos. II [Back-Center-off stage]: Clarinet (play into timpani) [without electronic amplification!]

Figure A-23: Details of the scoring of *Endless whispering*

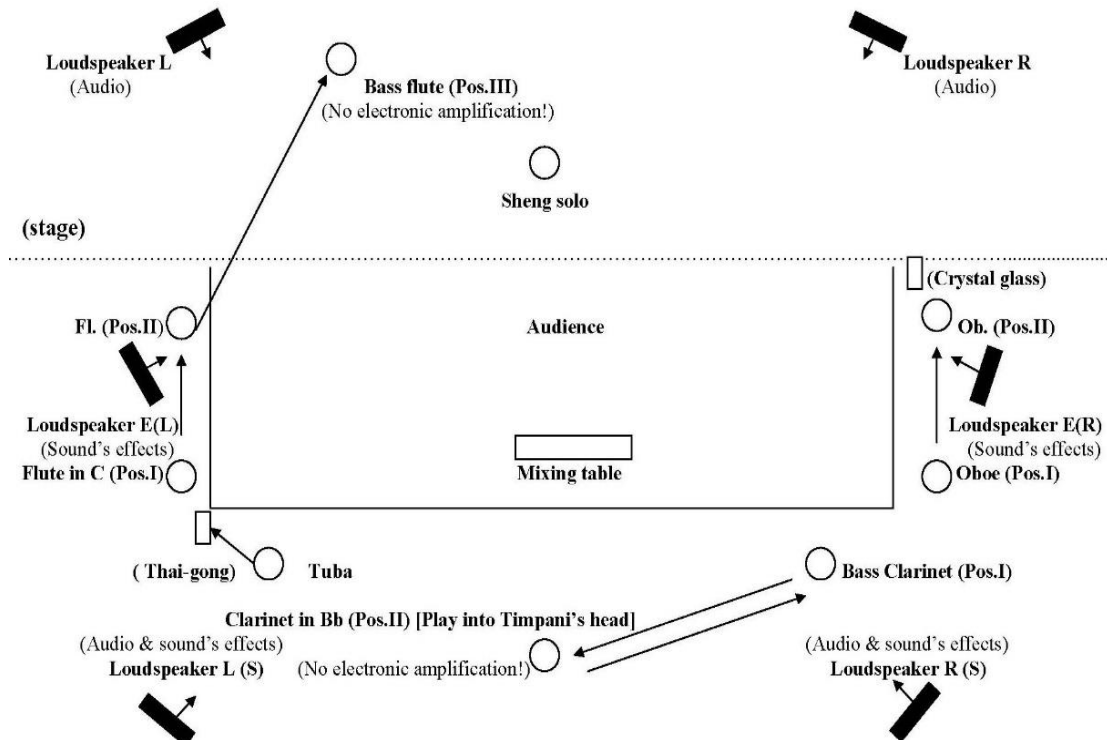

Figure A-24: Instrumental setup and spatialisation of live electronics in *Endless whispering*

Endless whispering was premiered on 26th November 2006 at the concert hall of Akademie der Künste. It is dedicated to the featured soloist Mr. Wei Wu and KNM Berlin's Ganesha. *Endless whispering* is my second piece to employ live

electronics; the first one is *Monodrama* (2004) for oboe solo and ensemble with live electronics. For the electronics part of this work, I combined sound files with nature sound samples and a mixture of sound effects derived from the instruments.

3.2. Playing techniques of the 37-reed soprano sheng in *Endless whispering*

The following are several examples of how I integrate 37-reed soprano sheng in *Endless whispering*:

3.2.1. Single-tone manipulation

In the traditional Chinese folk music for sheng, playing single tones is rare because traditionally the sheng is a chord instrument. In the opening section of *Endless whispering*, the sheng's single tone melody is enriched by the notated ornamentations, and chords with perfect fourth and octaves are built on the sustained B-natural.

Figure A-25: Bars 1–4, sheng part of *Endless whispering*

In the passage above, I introduce a modern vocalisation where the sheng player sings and plays in combination with various vibrato techniques. The reformed sheng⁴ in a modern orchestra is different from the traditional soprano sheng in terms of its mouthpieces. The traditional sheng's mouthpiece is short and round, whereas the reformed mouthpiece is a long thin tube with a very small embouchure hole. Consequently, it is hard and less effective to sing and play simultaneously on the modern sheng.



Figure A-26: Photo on the left shows the mouthpiece of a reformed sheng played by Mr. Lung Yi Huang; photo on the right shows the mouth piece of a traditional 37-reed soprano sheng played by Mr. Wei Wu. (Photo provided by Wei Wu)

⁴ “The traditional shengs are hand held by performers, who are required to learn sets of fingerings and how to cover air holes while playing. The reformed shengs are placed either on a player's lap or on a stand, and the performer is required to press levers or buttons while blowing to emit sounds” (Wong, 2005, p. 136).

3.2.2. Tonguing techniques

Sheng players embellish a sound and create different sound textures through breath and mouth techniques. Tonguing is one of the most common mouth techniques. Traditionally this technique is used to mimic the sound of drums, footsteps, cymbals, and the plucking of string instruments. In *“Endless whispering”*, I use various flutter-tonguing techniques to expand the timbre of the sheng part, including:

- i) Xi Huashe (細花舌; Small Flower Tongue): vibrate the tongue quickly to create tongue trills
- ii) Chu Huashe (粗花舌; Big Flower Tongue): normal flutter-tonguing
- iii) Bao Huashe (暴花舌; Erupt Flower Tongue): begin with big flutter tongue and then stop to make an accent and keep at one pitch or chord.

Besides the various flutter-tonguing techniques, I introduce dramatic improvisation on chromatic clusters in the passage shown below. All these playing techniques will trigger the live electronics creating delay effects in all the aforementioned sounds.

The image shows a musical score for the Sheng instrument, covering bars 5, 6, and 7. The score is written on a single staff with a treble clef and a key signature of one flat. It includes various musical notations such as slurs, accents, and dynamic markings. Annotations above the staff describe specific techniques: 'slower flutt.' above bar 5, '“Bao Huashe” fast & dense cluster flutt.' above bar 6, and '“Xi huashe”' above bar 7. A 'chromatic cluster (improv.)' is marked above a group of notes in bar 6. Below the staff, dynamic markings include *sf*, *pp*, *irregularly sempre*, *ff*, and *pp dolciss.*. A box labeled 'Dy' is positioned below bar 5. The score ends with a double bar line and repeat dots.

Figure A-27: Bars 5–7, sheng part of Endless whispering

3.2.3. Pan-flute airy sounds

In Fig. A-28, I introduce the timbre of “pan-flute” playing on the sheng. Three pitches (i.e., d^2 , g^2 , and c^3) on the 37-reed soprano sheng are applicable to this technique, which creates “pan-flute” airy sounds that resemble Shakuhachi playing:

Figure A-28: Bars 13–16, page 4 from full score of *Endless whispering*

Figure A-28: Bars 13–16, page 4 from full score of *Endless whispering*

3.2.4. Strike keys (or *Da Yin*) and shaking of sheng

In the traditional repertoire, “strike keys” (*Da Yin*) are often used to create ornamental percussive effects while a sustained sound is being played. A related contemporary technique is the “*Dou Yin*,” which means shaking the sheng to produce a strong accent and pitch fluctuation of chords.

The example of “*Da Yin*” and “*Duo-Yin*” is presented below:

Figure A-29: Bars 35–36, sheng part of *Endless whispering*

Figure A-29: Bars 35–36, sheng part of *Endless whispering*

3.2.5. Gliding effects

For the sheng, gliding (抹 *Mo Yin*) is defined as the gradual closing or opening of the holes on the instrument. The sheng player can play an upward gliding “*Shang Hua Yin*” (上滑音) and a downward gliding “*Xia Hua Yin*” (下滑音). This gliding technique only applies to the traditional shengs and cannot be executed on the reformed orchestra shengs. In the repertoire of the traditional folklore sheng, the gliding technique is often referred to as birds singing. In the 37-reed soprano sheng, the notes are usually glided a minor third higher or lower. Notes from a^2 – g^3 exhibit a clear gliding sound.

In Fig. A-30, the 37-reed soprano sheng creates gliding effects along the high note f^3 . After singing in a high falsetto voice with a vibrato, the player performs

the improvisational passage containing diatonic and chromatic clusters mixed with voice murmuring.

Figure A-30: Bars 55–56, sheng part of *Endless whispering*

3.2.6. Polyphonic writing

Polyphony or counterpoint is rare in traditional works but has recently become increasingly common in contemporary sheng repertoire. Below is an example of polyphonic writing for sheng:

Figure A-31: Bars 68–70, sheng part of *Endless whispering*

3.2.7. Singing into sheng

This technique is also rarely used in traditional repertoire. I adopt the “singing into Sheng” to make uncertain pitches “jump out” from the instrument while ensuring that the singing part is still clearly heard. This technique is especially effective when singing in a lower range.

Figure A-32: Bars 103–106, sheng part of *Endless whispering*

3.2.8. Multi-instrument playing

Most Asian traditional musicians can play several instruments in addition to their major instrument. Besides sheng, Mr. Wei Wu performs Mongolian throat singing and plays many other Chinese instruments such as xun, dizi, er hu, and Mongolian horse-head fiddle. In “Endless whispering,” I asked Mr. Wei Wu to play xun (Chinese ocarina), and the other musicians to perform instruments besides their major instrument. The tuba player has to play a Thai gong, and the oboist plays a crystal wine glass producing a sustained pitch by rubbing a finger on the rim of the glass (Fig. A-33).

Figure A-33: Bars 115–119, page 27 of full score of *Endless whispering*

4. *Horizon's chant*

In 2007, Mr. Wei Wu introduced me to Korean gayageum player Ms. Jocelyn Clark and Japanese koto player the late Ms. Ryuko Mizutani for a project at the Bayerischer Rundfunk (Germany) commissioned for their debut concert at the Musica Viva Festival 2007. For this commission, I composed *Horizon's chant* and dedicated the work to Mr. Wei Wu, Ms. Jocelyn Clark, and the late Ms. Ryuko Mizutani. This composition is my first piece for 37-reed soprano sheng, 13-string koto, and 12-string sanjo gayageum

The sanjo gayageum is a traditional Korean 12-string zither, and the koto is a traditional Japanese 13-string zither. In Korean folk music, the sanjo gayageum appeared with the emergence of sanjo music. Sanjo, literally meaning scattered melodies, is a musical form involving improvisation and singing. Both instruments' playing techniques are similar to those of other Asian instruments (such as the Chinese gu zheng, Mongolian yatga, and Vietnamese dan tranh). All these instruments require the left hand pressing the strings to raise the pitch, with the fingers performing various movements such as shaking, bending, and vibrating while the right hand plucks or strums the strings. Thanks to Ms. Clark and the late Ms. Mizutani, who spent many hours teaching me how to write for these particular instruments, I began my first study of the Korean sanjo gayageum and Japanese koto.

In *Horizon's chant*, the three musicians sit on the floor and line up to form a horizon. The 37-reed soprano sheng player is seated in the centre, between the gayageum player on the left and the koto player on the right. This setup renders the sheng a neutral character that merges with the Korean and Japanese sensations created by the gayageum and the koto. As we know, a 37-reed soprano sheng can perform the music of a 17-reed Japanese sho in the Japanese

gagagu music or the music of a 24-reed Korean saeng hwang in the Korean court music.

The seating of the three musicians and the tuning of the gayageum and koto are as follows:

4.1. Instrumental setup

Onstage: on the left side

Sanjo gayageum (12-string gayageum and voice; prepare a bow and a crystal glass with the pitch of



Initial tuning: (tuning in F, sounds a perfect fifth lower)



Sounding pitches:



Figure A-34: Tuning of the sanjo gayageum

On stage: in the centre

Sheng (37-reed soprano sheng)

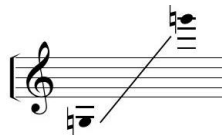

Figure A-35: Range of the 37-reed soprano sheng

On stage: On the left side

Koto (13-string koto and voice; prepare a bow and a crystal glass with the pitch of



Initial tuning:



Figure A-36: Tuning of the koto

4.2. Performing techniques applied in *Horizon's chant*

The following are examples from *Horizon's chant*:

4.2.1. Bowing and singing

In the opening of the piece, the koto player employs the bowing technique on the lowest F-string with different types of articulations; the gayageum player rubs the edge of the wine glass to produce a singing pitch of c-sharp and later hums the shadow pitch d-natural.

Figure A-37: Bars 1–5, page 1 of full score of *Horizon's chant*

4.2.2. Extended vocal techniques

In many of my compositions, I have included instructions for extended vocal techniques for instrumentalists. I frequently use grace notes (some of which span large intervals), trills that begin in slow tempo and subsequently accelerate, trills with various intervals, glissandi in various speeds, and repeated and sustained notes with various speeds of vibrato. For me, these techniques provide important creative possibilities for tonal inflections, pitch bending, non-pitch aspiration, heightened speech, and articulations.

The vocalisation for the three musicians in this piece is very crucial. Figures 38–41 present the different vocalisation techniques in this work:

Figure A-38: Bars 6–10, both the gayageum and koto players sing with various types of vibratos in *Horizon's chant*

Figure A-39: Bars 16–19, all three musicians produce a vocal unpitched white noise sound to imitate the wind and form an “echo” passage in *Horizon’s chant*

Figure A-40: Bars 29–33, both the gayageum and koto players murmur nonsense texts like incantations with whisper-like irregular accents

Figure A-41: Bars 34–40, “sing & play” in the sheng part.

4.2.3. Interchanging roles

Another important concept in this work is the interchanging roles between the gayageum and the koto in the recapitulation section. Comparing bars 1–10 in Figs. A-37 and A-38 with bars 107–116 in Fig. A-42 below, we see that the gayageum player starts to use bowing techniques and sings, whereas the koto player is assigned to rub the crystal wine glass to produce a B-natural whilst singing. However, the sheng player keeps playing the same part as he did in the opening section.

Figure A-42: Bars 107–116, the recapitulation section of *Horizon's chant*

5. *Shui.Mo* 水。墨 (Water.Ink)

In 2008, after the successful performances of *Endless whispering* and *Horizon's chants*, music director Mr. Etienne Siebens commissioned me to write for the Symfonieorkest Vlaanderen. After having great experiences working with Mr. Wei Wu and the musicians of the Dragon Ensemble, I wrote *Shui.Mo* (Water.Ink), a concerto for four Chinese instruments and a Western symphony orchestra. This piece consists of two movements that are played without a break. The first movement *Shui Wen* (ripples of water) is dedicated to my mentor Prof. Wen Chung Chou, and the second movement *Mo Yun* (charm of the ink) is written in memory of Korean composer Isang Yun.

Shui.Mo (Water.Ink) concerto is scored for four Chinese instruments (sheng, er hu, pipa, and gu zheng) and a Western symphony orchestra (2.2.2.2-4.2.2.1-timp-perc(3)-cel-hrp-str).

5.1. Spatialisation: Sonic mobility and possibilities created by instrumentation and instrumental setup

The spatial setup of the instruments during the performance is significant in this composition. I attempt to create the mobility of sound through the placement of the sheng soloist on stage. There are four positions on the stage for the soloist who walks from one to another during the performance. Different groups of Western musicians are placed in the auditorium: one group at the end of the auditorium, as far from the main stage as possible representing the “echo” group,

and the other groups are placed on either side of the audience. One can hear the “soundscape of water and ink” from different directions and perceive the depth of this new sonic world.

I explore the sonic possibilities of integrating traditional Chinese instruments with Western orchestra in *Shui.Mo* (Water.Ink). This composition shows a resemblance with a traditional Asian musical composition while creating a realisation technically and culturally suited to the Western manner of performance. With this spatial setup, two major musical concerns arise: first, the particularities of each instrument on its own; second, the way they interact with one another and create composite sounds. The composition will be a challenge to all creative minds during performance.

Below are the scoring and instrumental setup of the piece:

<u>Instruments</u>	
Back (onstage)	3 Percussions*
Center-back (C-B) (onstage)	2 Horns in F Trumpet in C Trombone Tuba
Center-left (C-L) (onstage)	Celesta Bassoon (<i>doubling on a small pair of Chinese cymbals</i>)
Center-right (C-R) (onstage)	Harp (<i>prepare a bow</i>) Double bassoon (<i>doubling on a small pair of Chinese cymbals</i>)
Center (onstage)	Timpani** (<i>doubling on small Japanese temple bowl gong, 3 bongos & wine glass***</i>)
Left side of the stage (onstage)	9 Violins 3 Violas 3 Cellos 2 Double bass
Right side of the stage (onstage)	9 Violins 3 Violas 3 Cellos 2 Double bass
Center-fore (onstage)	Erhu Pipa Gu zheng (<i>prepare a bow</i>) Sheng (<i>4 positions</i>) <i>Position 1</i> <i>Position 2</i> <i>Position 3</i> <i>Position 4 (Only Xun [Chinese ocarina])</i>
Left-side of audience (offstage)	Flute in C (<i>doubling on Piccolo & alto Flute</i>) Oboe (<i>doubling on wine glass***</i>) Clarinet in Bb
Right-side of audience (off stage)	Clarinet in Bb (<i>doubling on bass Clarinet</i>) Oboe (<i>doubling on wine glass***</i>) Flute in C (<i>doubling on Piccolo</i>)
Back of the audience (Echo) (offstage)	2 Horn in F (<i>left and right side; doubling on a small pair of Chinese cymbals</i>) Trumpet in C (<i>doubling on wine glass***</i>) Trombone (<i>doubling on wine glass***</i>)

Figure A-43: Scoring of *Shui.Mo*

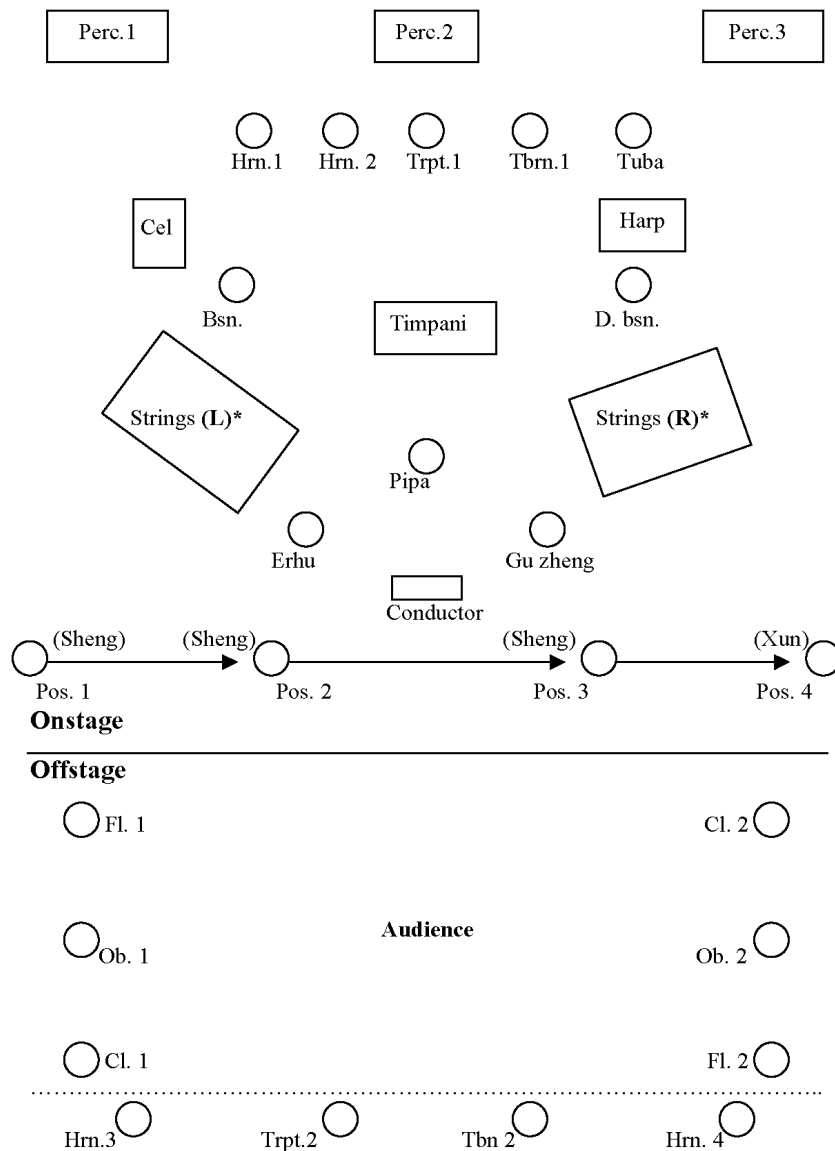

Figure A-44: Instrumental setup of *Shui.Mo*

5.2. Performing techniques for the Chinese instruments in *Shui.Mo*

The instrumental writing for the Chinese instruments in this composition aims to highlight the instruments' characteristic timbres with their traditional and contemporary playing techniques.

The musical score for bars 44-47 features four staves: Erhu, Pipa, Gu z., and Sheng. The notation includes various dynamic markings (pp, f, sfz, ppz, mfz, ffz) and performance instructions such as "improv...", "don't trem.", "L.H. gliss.", "bow pressure noise", "bouce bow on string", "(L.H) (heel) led up", "V bowing ad lib", and ">> dynamic fluctuations irregularly".

Figure A-45: Bars 44-47, the part of the Chinese instrumental ensemble in *Shui.Mo*

5.2.1. Vocalisation for the gu zheng

I employed two different types of vocalisation for the gu zheng player Ms. Feng Xia Xu. When playing the glissandi on the pipa, the performer also has to sing a vocal glissando in parallel perfect fourths to imitate the hooraying or sighing of Hakka mountain songs. At the same time, the gu zheng player sings a narrow-range melody within an interval of a perfect four, resulting in a strangely comforting cry that resembles the wordless songs of tribal people or Hakka mountain songs. One of the most unique characteristics of Hakka mountain songs is that they are frequently impromptu in nature, whether being sung by an individual or in a duet. In this gu zheng singing passage, I stated in the score that the player can freely interpret his/her own ornaments, or even improvise on the basis of the given melodic contours.

Figure A-46: Bars 48–61, the part of the Chinese instrumental ensemble in *Shui.Mo*

5.2.2. Right-hand finger tremolos with left-hand glissandi

The gu zheng player produces right-hand finger tremolos on the highest d-natural whilst the left hand plays glissandi on the strings across the right and left sides of the bridge.

Figure A-47: Bars 88–102, the part of the Chinese instrumental ensemble in *Shui.Mo*

5.2.3. “Aleatoric” improvisation

In this work, most of the passages for Chinese instruments are precisely notated except for the “aleatoric” passages, where I employ improvisation to build up the climax together with the orchestra, and the cadenza, where improvisation is used to develop dialogues among the instruments (Figs. 48 and 49):

Figure A-48: Bars 116–122, the part of the Chinese instrumental ensemble in *Shui.Mo*

Figure A-49: Bars 141–148, the part of the Chinese instrumental ensemble in *Shui.Mo*

5.2.4. Half-open form of improvisation

At the end of the piece, the sheng soloist plays the xun with contour-like melodies. The performer follows the notated rhythm but is allowed to play this melody in any key. This is a half-open form of improvisation. My intention is to create a flow with clear rhythmic gestures while leaving the melodic shapes and articulations to the player's decision and interpretation.

The musical score for Figure A-50 consists of four staves. The top staff is for Er-Hu, the second for Pipo, the third for G.Z., and the bottom for Sheng (Xun). The score is divided into two sections: 'G' and 'H'. Section 'G' is marked 'Molto calmo e lontano' with a tempo of ca. 42. Section 'H' is marked 'Tempo rubato' with a tempo of ca. 42. The score includes various dynamic markings such as ppp, pp, p, mp, and f. There are also performance instructions like 'Senza misura ca. 9"', 'molto rit.', 'Senza misura ca. 12"', and 'Completely silent'. The Sheng (Xun) part includes specific instructions like 'solo rubato & dynamics free (improvisation on given melody & rhythmic suggestion)', 'Pos. IV no pedal', 'wide vibr.', 'subtle & rubato', 'wide vibr.', and 'molto esp.'.

Figure A-50: Bars 100–109, second movement, the part of the Chinese instrumental ensemble in *Shui.Mo*

5.3. Orchestral instrumentation and echo effects in *Shui.Mo*

In the orchestral instrumentation of *Shui.Mo*, the strings are divided into two groups on stage, right and left. The two bassoons, brass, celesta, timpani, and harp are positioned in the centre, while four percussionists are in the back of the stage (Fig. A-44).

The string section creates a drone-like atmosphere with open fifths as background (Fig. A-51):

The musical score for Figure A-51 shows the opening section of *Shui.Mo* for the string section, divided into two groups: 'Left side (offstage)' and 'Right side (offstage)'. Each group includes parts for Violin, Viola, Cello, and Double Bass. The score is marked with various dynamics such as ppp, pp, p, mp, and f. There are also performance instructions like 'enter imperceptibly ppp dolcis.', 'end. v.', 'e.s.p.', 's.p.', 'molto', and 'molto esp.'. The score includes a variety of musical notations including notes, rests, and articulation marks.

Figure A-51: First movement, bars 1–7, the opening section of *Shui.Mo*

Spatial effects are explored by having different instrument groups placed at the far end of the auditorium from the main stage and on either side of the audience.

In this work, I employed three different Western instrument groups to create an echo effect from an offstage position to complement the Chinese instrument soloists and other instruments on the stage.

The following figures illustrate the different compositional methods for the echo groups in this composition:

5.3.1. Echo among offstage musicians

The two offstage clarinettists (on the left and right sides of the audience) present an echoing melody together with the brass quartet at the back of the audience.

Figure A-52: First movement, bars 80–87, offstage groups in *Shui.Mo*

5.3.2. Echo between offstage instruments and onstage Chinese instruments

The two offstage piccolos (on the left and right sides of the audience) perform a double echoing melody to respond to the onstage er hu, pipa, and sheng players' singing and playing of melodic lines.

Figure A-53: First movement, bars 109–115, offstage groups with onstage Chinese instrument groups in *Shui.Mo*

5.3.3. Echo between offstage instruments and onstage Western instruments

The two offstage clarinettists (on the left and right sides of the audience) present a double echoing melody to respond to the onstage first violins from the left-side and the right-side groups.

This musical score excerpt covers bars 68 to 73. It features multiple staves for Violins I and II, Violas, Cellos, and Double Basses. The notation includes various dynamic markings such as *pp*, *f*, and *sf*, along with performance directions like *molto* and *S.T.* (Sostenuto). The Horns (B.C. 1 and 2) are also present, with specific instructions like 'enter softly *pppp*' and 'slowly atten.'.

Figure A-54: Bars 68–73, offstage groups with onstage string groups in *Shui.Mo*

Some musicians are assigned additional instrument. For example, in the second movement’s build-up section, two of the offstage horn players play a pair of Chinese hand cymbals to create percussive effects from the back of the audience (Fig. 55):

This score excerpt covers bars 16 to 22. It includes parts for Flutes 1 and 2, Oboes 1 and 2, Clarinets 1 and 2, and Horns 3 and 4. The Horn parts (Hn. 3 and Hn. 4) are specifically annotated with instructions for playing Chinese cymbals: 'Pairs of small Chinese cymb. (high pitch)' and 'Pairs of Chinese cymb. (Medium high pitch)'. Additional performance directions include 'Rubbing in circular motion', 'strike and damp!', and 'poco a poco cresc.'.

Figure A-55: Second movement, bars 16–22, offstage groups in *Shui.Mo*

Wine glasses are another additional instrument assigned to several musicians in this composition. Four onstage and four offstage musicians have to play wine glasses forming a glass-harmonica effect to create a fluctuation of undetermined pitches in the background during the closing section.

Figure A-56: Bars 100–108, second movement, four onstage musicians (percussionists) play four wine glasses in *Shui.Mo*

Figure A-57: Bars 100–108, second movement, four offstage musicians (Ob1/Ob2/Tpt1/Tbn2) play four wine glasses in *Shui.Mo*

6. Summary

Through my compositional research and experience, I hope to create a new musical language that can be identified as the interaction between Eastern and Western musical materials. Most importantly, I aim to establish a strong connection and cooperation between disciplines of related art forms in this new approach to sound and culture. I hope the examples presented in this paper have illustrated the reciprocal stimulation of tone qualities, as well as demonstrated that materials and techniques should at a deeper level reflect the exchange between different cultural heritages bringing about challenging and thoughtful works.

The people whom I am writing for are a crucial part of my compositional process. I am always inspired by the musicians who will be premiering the works. The inspiration stems not only from how they are as musicians, but also from their personalities. The instrumentalists in a project are often musicians that I've been working with in my previous compositions. Working with great Chinese and Western musicians from two diverse disciplines has been a source of great inspiration to me. I have benefited from these experiences and learnt the value of developing strong rapport with the musicians I wrote for and to whom I have had the pleasure to dedicate these pieces. We have always pushed one another to attempt something new and innovative, and this fruitful collaboration is based on the advice and trust of the musicians. In the future, I intend to continue studying Asian music repertoires and culture heritages to find new sounds that reflect the confluence between East and West in my musical language.

I strongly believe that composer and performer can share their respect and excitement for new musical possibilities. Thus, most of my compositions have been deliberately scored for specific musicians. Collaborating with them has helped me to express my compositional philosophy and my approach to a new East-West aesthetics.

Bibliography

1. Cited references

Chapter I and Chapter II:

- China-Drama-Peking opera. In S. Sadie (Ed.), (1980), *The New Grove dictionary of music and musicians* (1st ed.). London: Macmillan.
- Chou, W. C. (2001). *Music – What is its future?*. Retrieved from <http://www.rogerreynolds.com/futureofmusic/chou.html>
- Hakka Affairs Council, (2006). Mountain songs and folk songs. Retrieved from <http://www.hakka.gov.tw/ct.asp?xItem=10420&ctNode=1026&mp=1&ps=>.
- Hsieh, T. Y. (1929). Origins and migrations of the Hakkas. *Chinese Social and Political Science Review*, 13, 202–27.
- Gong, W. Q. (Ed.). (n.d.). Booklet of the Quanzhou Theater (China) Representative list of intangible cultural heritage of humanity: Nanyin, Quanzhou String-and-Wind Ensemble. Quanzhou: Quanzhou Theatre.
- Ismail, A. R. H. (2004). Bumiputera (Bumiputra). In K. G. Ooi (Ed), *Southeast Asia: A historical encyclopedia, from Angkor Wat to East Timor* (Vol. 1). Santa Barbara: ABC-CLIO.
- Maceda, J. M. (2005). Rebellion, non-conformity, and alternatives. In R. P. Santos (Ed.), *Tunugan: Four essays on Filipino music* (pp. 125–178). Quezon City: University of the Philippines Press.
- Malaysian Chinese. (n.d.). In *World heritage encyclopedia*. Retrieved from http://community.worldheritage.org/articles/Malaysian_Chinese.
- Minford, J., & Lau, J. S. M. (Eds.). (2000). *Classical Chinese literature: An anthology of translations*. New York: Columbia University Press & Chinese University of Hong Kong.
- Saw, S. H. (2015). *The population of Malaysia* (2nd ed.). Singapore: Institute of Southeast Asian Studies.
- Spiller, H. (2004). *Gamelan: The traditional sounds of Indonesia*. ABC-CLIO world music series. Santa Barbara: ABC-CLIO.
- Takemitsu, T. (1987). My perception of time in traditional Japanese music.” *Contemporary Music Review*, 1(2), 9–13.
- Yu, P. (1981). *The poetry of Wang Wei: New translations and commentary*. Bloomington: Indiana University Press.
- Yuasa, J. (1989). Music as a reflection of a composer’s cosmology. *Perspectives of New Music*, 27(2), 176–197.

Chapter III:

- Bynner, W., & Kiang, K. H. (1922). Harmonizing a poem by Palace-Attendant Kuo: By Wang Wei. *Poetry*, 19(5), 241.
- Chen, Y. S. (2002). Yi zhong ti-xi, liang ge xi-tong. *Musicology in China*, 4, 109–116.
- Chi. In *Oxford dictionaries: Language matters*. Retrieved from <http://www.oxforddictionaries.com/definition/english/chi?q=qi#chi>
- Ch'in. In S. Sadie (Ed.), (1980), *The New Grove dictionary of music and musicians* (1st ed.) (p. 245). London: Macmillan.
- China_II Court traditions (ya-yueh). In S. Sadie (Ed.), (1980), *The New Grove dictionary of music and musicians* (1st ed.) (p.252). London: Macmillan.
- Chou, W. C. (1968). East and West, old and new. *Asian Music*, 1, 19.
- (2001). Music – What is its future?. Retrieved from <http://www.rogerreynolds.com/futureofmusic/chou.html>
- (2010). Yü Ko (1965). Retrieved from http://www.chouwenchung.org/works/1965_yu_ko.php
- Korea, 9-Folk music, Pansori. In S. Sadie (Ed.), (1980), *The new Grove dictionary of music and musicians* (1st ed.) (p.207). London: Macmillan.
- Pan-Chew, S., & Chen, J. J. (2010). An introduction to Chou Wen-chung's water image symmetry. Retrieved from http://www.chouwenchung.org/music/water_image_symmetry.php
- Song, B. S. (1973). *Korean music and instrument*. Seoul: National Classical Music Institute.
- Spiller, H. (2004). *Gamelan: The traditional sounds of Indonesia*. ABC-CLIO world music series. Santa Barbara: ABC-CLIO.
- Wang, R. R. (n.d.). Yinyang. In *The Internet Encyclopedia of Philosophy* (ISSN 2161-0002). Retrieved from <http://www.iep.utm.edu/yinyang>
- Zhu, Z. Y. (n.d.). Yuelü quanshu [Complete Book of Music and Stanza] (1931).14 volumes. Shanghai: Shangwu yinshuguan.

Chapter IV:

- Maceda, J. (1986). A concept of time in a music of Southeast Asia (A preliminary account). *Ethnomusicology*, 30(1), 11–53.
- Santos, R. P. (2006, June). A concept of time and space in Asian Artistic Expression. Lecture paper presented at a summit of the China-ASEAN Music Week, Nanning.

Lecture paper

Guoyue huqin [national instrument er hu]. In the Webpage of “Collection of cultural relics: Others” under the Art Cultural Research Center of Nanhua University. Retrieved from http://art2.nhu.edu.tw/page1/super_pages.php?ID=page101&Sn=5.

Hu, D. T. (1997). *Minzu guanxian yue fa* [Orchestration of national music]. Shanghai: Shanghai Music Publishing House.

Lee, H. (2015). Ajaeng. In Y. Kang, K. Kim, & H. Yim (Eds.), Program booklet of 2015 International Gugak Workshop. Retrieved from www.gugak.go.kr.

Turnbull, H. (1981). A Sogdian friction-chordophone. In D. R. Widdess & R. F. Wolpert (Eds.), *Music and tradition: Essays on Asian and other musics presented to Laurence Picken* (pp. 197–207). Cambridge; New York: Cambridge University Press.

Wang, R. R. (n.d.). Yinyang. In *The Internet Encyclopedia of Philosophy* (ISSN 2161-0002). Retrieved from <http://www.iep.utm.edu/yinyang>.

Wong, S. S. (2005). *Qi: An instrumental guide to the Chinese orchestra*. Y. Lim, J. Yang, & B. M. J. Tan (Eds.). Singapore: Teng, 2005.

Wu, Wei (2011). Unpublished lecture materials on the 37-reed traditional soprano sheng [“Sheng”: demonstration by Wei WU; notes organized by Roger Feria Jr. and 37-reed descant Sheng by Wei WU].

*All score examples are excerpted from the compositions by Kee Yong Chong, Edition Studio C.

2. General bibliography of books, articles and music scores

Books:

- Burt, P. (2001). *The music of Toru Takemitsu*. London: Cambridge University Press.
- Chou, W. C. (2003). *Chou Wen-chung music festival special album*. S. Pan-Chew (Ed.). Taipei: Jia Wei Audio.
- Diamond, J (Ed.). (2000). *Balungan: A publication of the American Gamelan Institution* (Vol. 7-8). Score Anthology 2000, Volume 7–8. Oakland: American Gamelan Institute.
- Griffiths, P. (1981). *Modern Music: The Avant Garde since 1945*. New York: George Braziller.
- Gulik, R. H. van (1940, 1969). *The lore of the Chinese lute: An essay in the ideology of the ch'in* (2nd ed.). Tokyo and Rutland, Vt.: Sophia University and Charles Tuttle.
- (1941). *Hsi K'ang and his poetical essay on the Chinese lute*. Tokyo: Monumenta Nipponica.
- Howard, K. (1995). *Korean Musical Instruments*. New York: Oxford University Press.
- Lai, E. C. (2015). *Biography on Chou: The music of Chou Wen-chung*. Farnham: Ashgate.
- Lieberman, F. (Trans.). (1983). *A Chinese zither tutor: The Mei-an Ch'in-p'u*. Washington and Hong Kong: Hong Kong University Press.
- Lindsay, J. (1992). *Javanese Gamelan: Traditional orchestra of Indonesia*. Singapore: Oxford University Press.
- McCredie, A. (2002) "Isang Yun" in *music of twentieth-century Avant-Garde: A biocritical sourcebook*. L. Sitsky (Ed.). London: Greenwood Press.
- McPhee, C. (1966). *Music in Bali: A study in form and Instrumental organization in Balinese orchestra music*. New Haven: Yale University Press.
- Ohtake, N. (1998). *Creative sources for the music of Toru Takemitsu*. Brookfield: Ashgate.
- Oja, C. J. (1990). *Colin McPhee: Composer in two worlds*. Washington: Smithsonian Institution Press.
- Popley, H. A. (2010). *The music of India*. India: Nabu Press.
- Tokita, A., & Hughes, D. W. (Eds.). (2008). *The Ashgate research companion to Japanese music*. Aldershot: Ashgate.
- Takemitsu, T. (1995). *Confronting silence*. Berkeley: Fallen Leaf Press.
- Yeung, J. L. (2012). *Standards of the guqin* (2nd ed.), Canada: Toronto Guqin Society.
- Yi, J. Y. (2011). *Contemporary gayageum notations for composers*. H. S. Kim (Trans.). H. V. Finchun-Sung (Ed.). Seoul: SNU Press.

Zhu, Z. Y. (n.d.). *Yuelü quanshu [Complete Book of Music and Stanza] (1931)*. 14 volumes. Shanghai: Shangwu yinshuguan.

Articles:

Chang, P. (2001). Chou Wen-Chung's cross-cultural experience and his musical synthesis: The concept of syncretism revisited. *Asian Music*, 32(2), 93–118.

Chen, Y. S. (2002). Yi zhong ti-xi, liang ge xi-tong. *Musicology in China*, 4, 109–116.

Ch'en, M. C. (1959). The heterophonic factor in Chinese music. *Musical Research Quarterly*, 4.

Cohen, M. L. (1968). The Hakka or "guest people": Dialect as a sociocultural variable in Southeastern China. *Ethnohistory*, 15(3), 237–292.

Cho, E. S. (2003). The relationship between Isang Yun's compositional techniques and Korean traditional music collection of folk study. *A collection of essays on Korean traditional music (Vol. 7)*. Seoul: Tuh Publication Company.

Chou, W. C. (1998). Towards a re-merger in music. In E. Swartz & B. Childs (Eds.), *Contemporary composers on contemporary music* (pp. 309–315). New York: Da Capo Press.

Chou, W. C. (1968). Single tones as musical entities: An approach to structured deviations in tonal characteristics. In *American Society of University Composers, Proceedings of the Third Annual Conference* (pp. 86–97).

----- (1970). Single tones as musical entities: An approach to structured deviations in tonal characteristics. In *American Society of University Composers (Vol. III)*.

----- (1983). Asian aesthetics and world music. *Asian Composers League Conference and Festival, 1981 Final report*. Hong Kong: Hong Kong Composers Guild.

----- (1983). Asian influence on Western music: Influence or Confluence?. In Korean National Commission for UNESCO (Ed.), *Traditional Korean Music*. Oregon: Pace International Research, Inc.

----- (1998). Towards a re-merger in music. In E. Swartz & B. Childs (Eds.), *Contemporary composers on contemporary Music* (pp. 309–315). New York: Da Capo Press.

----- (2004). Wenren and culture. In Y. U. Everett & F. Lau (Eds.), *Locating East Asia in Western art music*. Middletown: Wesleyan University Press.

----- (2007). Whither Chinese composers?. *Contemporary Music Review*, 26(5–6), 501–510.

Diamond, J. (1990). There is no they there. *Musicworks*, 47, 12–23.

Everett, Y. U. (2007). Calligraphy and musical gestures in the late works of Chou Wen-chung. In E. Green & L. Liang (Eds.), *China and the West: The birth of a new music* (pp. 569–584). Basingstoke: Taylor & Francis

Feliciano, F. F. (1983). Isang Yun. In *Four Asian contemporary composers: The influence of tradition in their works*. Quezon City: New Day Publishers.

- Freeman, R., & Scelsi, G. (1991). *Tanmatras: The life and work of Giacinto Scelsi*. *Tempo, New Series*, 176, 8–18.
- Han, K. H. (1989). Folk songs of the Han Chinese: Characteristics and classifications. *Asian Music*, 20(2), 107–128.
- Hill, R. D., & Shin, V. M. (1990). Occupational and spatial mobility in an overseas Chinese agricultural community: The Hakkas of Kudat, Sabah, Malaysia. *Sojourn: Journal of Social Issues in Southeast Asia*, 5(2), 194–218.
- Kirchert, K. U. (1998). Between worlds: Reflections on ritual in the music of Giacinto Scelsi. *The World of Music*, 40(1), 79–100.
- Kunz, H. (1980). Yun, Isang. In S. Sadie (Ed.), *The new Grove dictionary of music and musicians* (Vol. 20). London: Macmillan.
- Lai, E. C. (1993–1994). Toward a theory of pitch organization: The early music of Chou Wen-Chung. *Asian Music*, 25(1/2), 177–207.
- (1997). Modal formations and transformations in the first movement of Chou Wen-Chung's "Metaphors." *Perspectives of New Music*, 35(1), 153–185.
- Maceda, J. (1966). International music symposium in Manila on "The Musics of Asia." *The World of Music*, 8(4/5), 79–80.
- (1974). Drone and melody in Philippine musical instruments. In Mohd. Taib Osman (Ed.), *Traditional Drama and Music of South Asia* (pp. 246–273). Kuala Lumpur: Kementerian Pelajaran Malaysia.
- McPhee, C. (1949). The five-tone Gamelan music of Bali. *The Musical Quarterly*, 35(2), 250–281.
- Mok, R. T. (1966). Heterophony in Chinese folk music. *Journal of the International Folk Music Council*, 18, 14–23.
- Nakano, K. (2014). Introduction to living composition: A new approach of Asian music, culture and spirituality. *Kuandu Music Journal*, 20, 85–104.
- Napier, J. (2006). A "failed" unison or conscious differentiation: The notion of "heterophony" in North Indian vocal performance. *International Review of the Aesthetics and Sociology of Music*, 37(1), 85–108.
- Provine, R. C., Tokumaru, Y., & Witzleben, L. J. (Eds.). (n.d.). Archaeology and History of Musical Instruments in China. In *Garland Encyclopedia of World Music Volume 7 - East Asia: China, Japan, and Korea* (pp. 143–152). Routledge. Retrieved on May 27, 2016, from Music Online: Garland Encyclopedia of World Music.
- Raseuki, N. I. (1998). New music in Indonesia. *The experience of the New Jakarta Ensemble*. Madison: University of Wisconsin.
- Rinser, L., & Yun, I. S. (2005). *Der Verwundete Drache [The wounded dragon]*. I. S. Yung (Trans.). Seoul: Random House Korea, 2005.
- Sciannameo, F. (2001). A personal memoir: Remembering Scelsi. *The Musical Times* 142 (1875), 22–26. London: Orpheus.

- Smaldone, E. (1989). Toru Takemitsu's *November Steps* and *Autumn*. *Perspective of New Music*, XXVII(2), 216–231.
- Takemitsu, T. (1989). Contemporary music in Japan. *Perspective of New Music*, XXVII(2), 198–214.
- Tenzer, M. (2003). José Maceda and the paradoxes of modern composition in Southeast Asia. *Ethnomusicology*, 47(1), 93–120.
- Tenzer, M. (2008). Temporal transformations in cross-cultural perspective: Augmentation in Baroque, Carnatic and Balinese music. In C. Utz (Ed.), *Music Theory and Interdisciplinarity*. 8th Congress of the Gesellschaft für Musiktheorie Graz 2008 (musik.theorien der gegenwart, Vol. 4) (pp. 517–530). Saarbruecken: Pfau 2010.
- Yuasa, J. (1989). Music as a reflection of a composer's cosmology. *Perspective of New Music*, XXVII(2), 176–197.

Music Scores:

- Baes, J. (2003). *Patangis-Buwaya [and the crocodile weeps] for four sub-contrabass recorders or any blown instruments*. Unknown: Self-published.
- Chen, Q. G. (1991). *Poème lyrique II for baritone and instrumental ensemble*. Paris: Gerard Billaudot Editeur.
- Chen, X. Y. (1996/2002). *Circuit for zheng*. Hamburg: Sikorski.
- (1989). *Duet for violin and zheng*. Hamburg: Sikorski.
- (2002). *XI - Fusion III for zheng, voice, sheng and temple bowls*. Hamburg: Sikorski.
- (2004). *Interlaced fragments for sheng solo*. Hamburg: Sikorski.
- (2004). *Invisible landscapes for zheng, percussion, piano and ensemble*. Hamburg: Sikorski.
- Chin, U. S. (2009). *Su concerto for sheng and orchestra*. London: Boosey & Hawkes.
- Chou, W. C. (1965). *Yu Ko for violin, winds, piano, and percussion*. New York: C.F. Peters.
- (1989). *Echoes from the Gorge for percussion quartet*. New York: C.F. Peters.
- (1996). *String quartet (No.1), "Clouds."* New York: C.F. Peters.
- (2003). *String quartet (No.2), "Streams."* New York: C.F. Peters.
- (2007). *Twilight colors, double trio*. New York: C.F. Peters.
- (2009). *Ode to eternal pine for flute, clarinet, violin cello, percussion and piano*. New York: C.F. Peters.
- Eötvös, P. (1995). *Atlantis for Orchestra*. Berlin: Ricordi.
- (1996). *Shadow for flute, clarinet and ensemble*. Berlin: Ricordi.

- Harvey J. (1994). *Advaya for cello, electronic keyboard and Electronics*. London: Faber.
- (1995). *Wheel of emptiness for ensemble*. London: Faber.
- Hosokawa, T. (1987). *Ferne Landschaft I for orchestra*. Tokyo: Schott Music.
- (1996). *Ferne Landschaft III for orchestra*. Tokyo: Schott Music.
- Jia, G. P. (2014). *The pine-soughing valleys for sheng, guzheng and orchestra*. Hamburg: Sikorski.
- (2002). *The wind sounds in the sky for sheng, violoncello and percussion*. Hamburg: Sikorski.
- Kurtág, G. (1989). *Grabstein für Stephan guitar and instrumental groups, Op. 15C*. Budapest: Editio Musica Budapest.
- Lim, L. (2009). *Invisibility for cello with 2 bows*. Munich: Ricordi.
- (2004–2005). *The quickening for soprano and qin (Chinese zither)*. London: Ricordi.
- Maceda, J. (1997). Music for Gongs and Bamboo. In *The José Maceda Collection*. Quezon City: University of Philippines Press.
- Qin, W. C. (1998). *He-yi for zheng and ensemble*. Hamburg: Sikorski.
- (2005). *The sun shadow vi for chamber ensemble*. Hamburg: Sikorski.
- (2010). *Calling for phoenix for suo na and orchestra*. Hamburg: Sikorski .
- (2011). *Two pieces for zheng solo*. Hamburg: Sikorski.
- (2006). *Pipa words for pipa solo*. Hamburg: Sikorski.
- Scelsi, G. (1960). *Hô cinque melodie per soprano solo*. M. Hirayama. Paris: Salabert.
- (1959). *Quattro pezzi su una nota sola*. Paris: Salabert.
- (1965). *Anahit for violin & 18 instruments*. Paris: Salabert.
- Sjukur S. A. (2004). *Gamelan: Game-Land for full Sundanese gamelan orchestra slendro-pelog and female voice*. Unknown: Self-published.
- (2005). *Game-Land 2 for Javanese gamelan orchestra slendro*. Unknown: Self-published.
- Takemitsu, T. (1967). *November Steps*. New York: C.F. Peters.
- (1987). *A flock descends into the Pentagonal Garden*. Paris: Salabert.
- Ung, C. (2005). *Aura for 2 sopranos, flute, Oboe, Clarinet, Percussion, 2 Violins, 2 Violas, cello and double bass*. New York: C.F. Peters.
- (1987). *Spiral for cello, piano, and percussion*. New York: C.F. Peters.

- (1980). *Khse buon for violoncello solo*. New York: C.F. Peters.
- Webern, A. (1927-28). *Symphonie*, Op. 21. Universal Edition.
- (1936). *Variation for piano*, Op. 27. Universal Edition.
- Yuasa, J. (1986). *Cosmos haptic II: Transfiguration for piano*. Tokyo: Schott.
- Yun, I. S. (1966). *Reak for full orchestra*. Berlin: Bote & Bock.
- (1971). *Piri for oboe solo*. London: Boosey & Hawkes.
- (1978). *Muak for orchestra*. Berlin: Bote & Bock.

List of figures

Figure I-1: Instrumental setup of <i>Hak.Qin</i>	17
Figure I-2: Bars 1–7, soloist part of <i>Hak.Qin</i> (2013).....	18
Figure II-1: Calligraphy specially written for <i>Shui.Mo</i> by Prof. Wen Chung Chou....	21
Figure II-2: From left to right: Kee Yong Chong (composer) and soloists of Dragon Ensemble, Feng Xia Xu (gu zheng), Ya Dong (pipa), Zhen Fang Zhang (er hu) and Wei Wu (traditional 37-reed soprano sheng) (Photo credited by Sigrid Tanghe).....	22
Figure II-3: Instrumental setup of <i>Shui.Mo</i>	23
Figure II-4: Bars 48–61, Chinese instrument ensemble part of <i>Shui.Mo</i>	24
Figure II-5: Bars 141–148, ending section of the first movement of <i>Shui.Mo</i>	25
Figure II-6: Bars 30–36, build up section of the second movement of <i>Shui.Mo</i>	26
Figure II-7: Bars 100–109 in the second movement, sheng soloist playing the xun in the ending section of <i>Shui.Mo</i>	27
Figure II-8: Instrumental setup of <i>Bie Ge</i>	29
Figure II-9: Bars 71–75, while whispering the text of “Song of Chu,” the choir members have to rub and scrunch withered bamboo leaves as percussion instruments in Section G of <i>Bie Ge</i>	30
Figure II-10: Traditional 24-reed soprano sheng player Mr. Lung-Yi Huang wandering on and off the stage freely in <i>Bie Ge</i> (Photo credited by Ding Hao Lin © 林鼎皓).....	31
Figure II-11: Bars 91–95, choral singers play xuns of different sizes, producing imperfect chanting sounds in <i>Bie Ge</i>	32
Figure II-12: All the offstage choral members playing xuns of different sizes (Photo credited by Ding Hao Lin © 林鼎皓)	32
Figure II-13: Bars 106–110, a boy soprano sings the folk song-inspired melodies among the audience, and a vocal quartet moves onto the stage and surround the piano, expressing the yearning for home and family in <i>Bie Ge</i>	33
Figure II-14: Vocal quartet moving onto the stage and surrounding the piano, expressing the yearning for home and family in <i>Bie Ge</i> (Photo credited by Ding Hao Lin © 林鼎皓)	34
Figure II-15: Two percussionists playing two large and deep bianzhong in the ending section of <i>Bie Ge</i> (Photo credited by Ding Hao Lin © 林鼎皓)	34
Figure II-16: Bars 116–110, ending passage showing the boy soprano, choir members (offstage), xun, and two large bianzhongs (onstage) in <i>Bie Ge</i>	35
Figure II-17: Instrumental setup of <i>Xun Feng</i>	37
Figure II-18: Bars 162–167, eight selected musicians (on stage and off stage) play back the ringtone of Mrs. Liao’s singing from Section G (beginning at bar 158) to the end of the piece	38
Figure II-19: Different tunings for the gu zheng soloist, Gu Zheng I & II, and pipa soloist	39
Figure II-20: Gu zheng solo (bars 1–6).....	39
Figure II-21: Gu zehng I (bars 1–6)	39
Figure II-22: Gu zheng II (bars 1–6).....	39
Figure II-23: Bars 14–19, pipa and gu zheng soloists’ vocalisation passage in <i>Xun Feng</i>	40
Figure II-24: Bars 1–7, percussion section in <i>Xun Feng</i>	40
Figure II-25: Bars 8–13, Percussion 4 playing 2 low gongs on the fourth beat of the bar	40
Figure II-26: Bars 26–31, sheng and dizi section in <i>Xun Feng</i>	41
Figure II-27: Bars 133–138, sheng and dizi section in <i>Xun Feng</i>	41

Figure II-28: Ink painting “Clouds” by German painter Mrs. <i>Helena Belzer</i>	42
Figure II-29: Rehearsal with Momenta Quartet, from the left to right: Emilie-Anne Gendron (violin), Asmira Woodward-Page (violin), Kee Yong Chong (Composer), Stephanie Griffin, (viola), Michael Haas (cello)	42
Figure II-30: Scordatura for the string instruments in <i>Yun Yong</i>	43
Figure II-31: Instrumental setup of <i>Yun Yong</i>	44
Figure II-32: Bars 1–6, opening section of <i>Yun Yong</i>	44
Figure II-33: Bars 17–25, half-open and quasi-improvisational imitation passage in the beginning of Section A for all the players in <i>Yun Yong</i>	45
Figure II-34: Bars 56–61, quasi-improvisation for all the players of <i>Yun Yong</i>	46
Figure II-35: Bars 95–104, the ending of Section D and the beginning of Section E in <i>Yun Yong</i>	46
Figure II-36: Bars 171–181, beginning of Section I, with new materials for the half-open and quasi-improvisational imitation passage for all the players of <i>Yun Yong</i>	47
Figure II-37: Bars 182–199, high harmonics improvisation contours of Violins I and II in the ending section of the piece of <i>Yun Yong</i>	48
Figure II-38: The tuning of cello.....	49
Figure II-39: Bars 1–5, opening section of <i>Timeless echoes</i>	49
Figure II-40: Track 1 (A) of the pre-recorded audio file of <i>Timeless echoes</i>	50
Figure II-41: Track 2 (B) of the pre-recorded audio file of <i>Timeless echoes</i>	50
Figure II-42: Track 3 (retrograde of B) of the pre-recorded audio file of <i>Timeless echoes</i>	51
Figure II-43: Track 4 (retrograde of A) of the pre-recorded audio file of <i>Timeless echoes</i>	51
Figure II-44: Basic structure of <i>Timeless echoes</i>	52
Figure II-45: Performance of <i>Timeless echoes</i> , painter Sigird Tanghe and cellist Arne Deforce. (Photo credited Virginie Schreyen)	52
Figure II-46: Cellist Arne Deforce performing the “Bottle-neck” technique on his cello to imitate the guqin in <i>Timeless echoes</i> (Photo credited Evy Ottermans).....	53
Figure II-47: Section A, bars 7–9, “Bottle-neck” technique on the cello	53
Figure II-48: Bars 72–76, melody played on the extremely high register of the cello	54
Figure II-49: Bars 91–100, improvisation section and improvisation-like melody (bars 97–100) played on the extremely high register of the cello.....	54
Figure II-50: Bars 120–124, Section R, recapitulation section of <i>Timeless echoes</i>	54
Figure III-1: From left to right: Wei Wu (sheng), Friedemann Werzlau (percussion), Kee Yong Chong (composer), Sawami Kiyoshi (piano), Prodromos Symeonidis (piano), Ya-ou Xie (conductor) and Adam Weisman (percussion).....	56
Figure III-2: First page of <i>Yuan-Fei</i>	57
Figure III-3: First page of <i>Yuan-He</i>	58
Figure III-4: Improvisation passages in Pianos 1 and 2 (bar 27) and the sheng part (bar 28) of <i>Yuan-Liu</i>	59
Figure III-5: Bar 32, improvisation passages for Percussionist 1 in <i>Yuan-Liu</i>	59
Figure III-6: Improvisation passages for Percussionist 2 (bar 74) and the sheng part (bar 76) of <i>Yuan-Liu</i>	60
Figure III-7: Bars 1–11, Section A of the sheng part in <i>Yuan-Liu</i>	60
Figure III-8: Bars 16–27, Section B of the sheng part in <i>Yuan-Liu</i>	61
Figure III-9: Bars 28–60, Section C of the sheng part in <i>Yuan-Liu</i>	61
Figure III-10: Bars 61–75, Section D of the sheng part in <i>Yuan-Liu</i>	62
Figure III-11: Bars 76–85, Section E of the sheng part in <i>Yuan-Liu</i>	62
Figure III-12: Bars 86–114, Section C’ of the sheng part in <i>Yuan-Liu</i>	63
Figure III-13: Bars 115–126, Section B’ of the sheng part in <i>Yuan-Liu</i>	63
Figure III-14: Bars 127–146, Section A’ of the sheng part in <i>Yuan-Liu</i>	64
Figure III-15: Compositional structure of the sheng part in <i>Yuan-Liu</i>	64

Figure III-16: Compositional structure of <i>Wu Yan</i>	66
Figure III-17: Section A, bars 1–4 of <i>Wu Yan</i>	66
Figure III-18: Section A', bars 154–157 of <i>Wu Yan</i>	67
Figure III-19: Section B, bars 11–13, of <i>Wu Yan</i>	67
Figure III-20: Section B', bars 164–166, of <i>Wu Yan</i>	68
Figure III-21: Compositional structure of <i>Yuan-Liu</i>	69
Figure III-22: Opening section of rehearsal mark-A of <i>Liu-Xu-Fei</i> (柳絮飛) for oboe and cello (2001).....	71
Figure III-23: Recapitulation section (rehearsal mark C) of <i>Liu-Xu-Fei</i> (柳絮飛) for oboe and cello (2001).....	72
Figure III-24: Bars 6-10, the sheng part performs different types of tremolo and grace notes in <i>Yuan-Liu</i>	72
Figure III-25: Bars 59-63, in bar 61, the sheng employs the traditional ornamentation techniques “He” (adding free notes to create different chords).....	72
Figure III-26: Chinese ancient chromatic scale based on 2:3 and 4:3 (perfect fifth up and perfect fourth down) ratios intervals.....	73
Figure III-27: Just intonation with cycle of fifths and fourths that is re-ordered to form three sets of pentatonic scales in “Do” mode.....	74
Figure III-28: Some of the tunings of Chinese instruments.....	74
Figure III-29: Sheng playing D major scale with perfect fifth and octave as harmonisation.....	74
Figure III-30: C natural and with G quartertone flat , D flat and with A 3-quarter tone flat . These two pairs of non-pure fifth open strings are the main musical elements in this work.....	75
Figure III-31: C quartertone flat and D flat quartertone flat throughout the whole piece.....	75
Figure III-32: Opening section of <i>Metamorphosis I</i> for viola and harp (2000, rev. 2007).....	75
Figure III-33: Bars 1–5, cello scordatura in <i>Timeless echoes</i>	76
Figure III-34: Bars 1–5, scordatura of all the string instruments in <i>Yun Yong</i>	76
Figure III-35: Pairing of tam-tams (acting as female & male) in Percussionists 1 and 2 in <i>Yuan-Liu</i>	77
Figure III-36: Pairings in the percussion instruments in <i>Yuan-Liu</i>	77
Figure III-37: Bars 11–15, crotales passages for Percussionist 1 in <i>Yuan-Liu</i>	78
Figure III-38: Bars 137–141, crotales passages for Percussionist 2 in <i>Yuan-Liu</i>	78
Figure III-39: Bars 1–5, pitches for the sheng part.....	78
Figure III-40: Bars 6–10, pitches for Piano 1.....	78
Figure III-41: Bars 1–5, pitches for Piano 2.....	79
Figure III-42: Bars 27–31, pitches for Percussion 1.....	79
Figure III-43: Bars 85–89, pitches for Percussion 2.....	79
Figure III-44: Opening section of <i>Temple bell still ringing in my heart</i> for viola solo (2002).....	80
Figure III-45: Bars 22–36, vocalisation between the sheng and Percussionist 2.....	81
Figure III-46: Bars 27–31, vocalisation among the sheng, Piano 1, and Piano 2.....	81
Figure III-47: Instrumental setup and mobility to three solo positions of <i>Wu Yan</i>	82
Figure III-48: Bars 22–26, imitation between Pianos 1 and 2 and also between Percussionist 2 and the sheng in bar 24.....	83
Figure III-49: Bars 122–126, imitation and interplay between Pianos 1 and 2 and also between Percussionist 1 and the sheng in bar 124.....	83
Figure III-50: Bars 1–5, original section of <i>Yuan-Liu</i>	84
Figure III-51: Bars 127–131, recapitulation section of <i>Yuan-Liu</i>	84
Figure III-52: Bars 16–21, original section of <i>Yuan-Liu</i>	85
Figure III-53: Bars 116–121, recapitulation section of <i>Yuan-Liu</i>	85

Figure III-54: Instrumental setup of <i>Metamorphosis VI-Wind prayer</i>	87
Figure III-55: Bars 25–27 of <i>Metamorphosis VI-Wind prayer</i>	88
Figure III-56: Bars 28–32 of <i>Metamorphosis VI-Wind prayer</i>	89
Figure III-57: Score reproduced from Gruppen by Stockhausen, copyrighted by Universal Edition	90
Figure III-58: Instrumental setup of <i>Endless whispering</i>	91
Figure III-59: Instrumental setup of <i>Yuan-Liu</i>	91
Figure A-1: Instrumental setup of <i>Metamorphosis VI-Wind prayer</i>	99
Figure A-2: Mr. Wei Wu and his 37-reed soprano sheng (photo provided by Wei Wu)	100
Figure A-3: 37-reed fingering chart and the range (finger chart provided by Wei Wu)	101
Figure A-4: Ms. Feng Xia Xu and her 21-string gu zheng (photo provided by Feng Xia Xu)	102
Figure A-5: 21-string gu zheng’s tuning for <i>Metamorphosis VI-Wind prayer</i>	102
Figure A-6: A folk music musician playing the yazheng (Photo from an online resource)	103
Figure A-7: Ms. Hwayeon Lee, first chair of Ajeang of the Contemporary Gugak Orchestra, National Gugak Center, demonstrated bowing techniques on Ajeang in the 2015 Gugak International GUGAK Workshop on 23 June 2015. (Photo credited by Kee Yong Chong)	103
Figure A-8: Feng Xia Xu used bowing techniques on the gu zheng in the dress rehearsal with the Singapore Chinese Orchestra for “Hak.Qin” composed by Kee Yong Chong (Photo credited by Kee Yong Chong)	103
Figure A-9: Bow bouncing on string; left hand pressing to produce vibrato while bowing; left hand gliding on the left side of the instrument (bars 34–40 in the first movement, gu zheng part of <i>Shui.Mo</i>)	104
Figure A-10: Left hand pressing the lowest string to produce different types of pitch bending (bars 44–47 in the first movement, gu zheng part of <i>Shui.Mo</i>)	104
Figure A-11: Singing the notated melody while bowing with strong bow pressure (bars 55–60 in the first movement, gu zheng part of <i>Shui.Mo</i>)	104
Figure A-12: Left hand plucking the normal right side of the strings as improvisation while bowing; left hand gliding on the left side of the instrument (bars 59–63 in the second movement, gu zheng part of <i>Shui.Mo</i>)	104
Figure A-13: Bowing the lowest string with left hand, pressing the string to produce different types of pitch bending; continuing the pitch-bending improvisation randomly; left hand gliding on the left side of the instrument (bars 49–52, gu zheng part of <i>Yuan-He</i>)	104
Figure A-14: Left hand gliding and strumming the left side of the instrument, then using left hand to press the lowest string to produce vibrato-like pitch bending according to the notated rhythmic pattern (bars 49–52, gu zheng part of <i>Yuan- He</i>)	104
Figure A-15: Bowing the string with left hand, pressing lightly and gliding to produce the harmonic sweeping sounds (bars 105–108, gu zheng part of <i>Yuan- He</i>)	105
Figure A-16: Bar 5, gu zheng part of <i>Metamorphosis VI-Wind prayer</i>	105
Figure A-17: Bars 11–12, gu zheng part of <i>Metamorphosis VI-Wind prayer</i>	105
Figure A-18: Bars 13–15, pipa, gu zheng, bass drum, harp, and piano parts of <i>Metamorphosis VI-Wind prayer</i>	106
Figure A-19: Bars 9–12, pipa, oboe, and percussion parts of <i>Metamorphosis VI- Wind prayer</i>	106
Figure A-20: Bars 9–12, three offstage instruments flute, clarinet, and sheng parts of <i>Metamorphosis VI-Wind prayer</i> -	107

Figure A-21: Bars 13–15, three offstage instruments flute, clarinet, and sheng parts of <i>Metamorphosis VI-Wind prayer</i>	107
Figure A-22: Bars 25–27, oboe, pipa, percussion, double bass, harp, and gu zheng parts of <i>Metamorphosis VI-Wind prayer</i>	108
Figure A-23: Details of the scoring of <i>Endless whispering</i>	109
Figure A-24: Instrumental setup and spatialisation of live electronics in <i>Endless whispering</i>	109
Figure A-25: Bars 1–4, sheng part of <i>Endless whispering</i>	110
Figure A-26: Photo on the left shows the mouthpiece of a reformed sheng played by Mr. Lung Yi Huang; photo on the right shows the mouth piece of a traditional 37-reed soprano sheng played by Mr. Wei Wu. (Photo provided by Wei Wu).....	110
Figure A-27: Bars 5–7, sheng part of <i>Endless whispering</i>	111
Figure A-28: Bars 13–16, page 4 from full score of <i>Endless whispering</i>	112
Figure A-29: Bars 35–36, sheng part of <i>Endless whispering</i>	112
Figure A-30: Bars 55–56, sheng part of <i>Endless whispering</i>	113
Figure A-31: Bars 68–70, sheng part of <i>Endless whispering</i>	113
Figure A-32: Bars 103–106, sheng part of <i>Endless whispering</i>	113
Figure A-33: Bars 115–119, page 27 of full score of <i>Endless whispering</i>	114
Figure A-34: Tuning of the sanjo gayageum.....	115
Figure A-35: Range of the 37-reed soprano sheng.....	115
Figure A-36: Tuning of the koto.....	115
Figure A-37: Bars 1–5, page 1 of full score of <i>Horizon’s chant</i>	116
Figure A-38: Bars 6–10, both the gayageum and koto players sing with various types of vibratos in <i>Horizon’s chant</i>	116
Figure A-39: Bars 16–19, all three musicians produce a vocal unpitched white noise sound to imitate the wind and form an “echo” passage in <i>Horizon’s chant</i>	117
Figure A-40: Bars 29–33, both the gayageum and koto players murmur nonsense texts like incantations with whisper-like irregular accents.....	117
Figure A-41: Bars 34–40, “sing & play” in the sheng part.....	117
Figure A-42: Bars 107–116, the recapitulation section of <i>Horizon’s chant</i>	118
Figure A-43: Scoring of <i>Shui.Mo</i>	119
Figure A-44: Instrumental setup of <i>Shui.Mo</i>	120
Figure A-45: Bars 44–47, the part of the Chinese instrumental ensemble in <i>Shui.Mo</i>	120
Figure A-46: Bars 48–61, the part of the Chinese instrumental ensemble in <i>Shui.Mo</i>	121
Figure A-47: Bars 88–102, the part of the Chinese instrumental ensemble in <i>Shui.Mo</i>	122
Figure A-48: Bars 116–122, the part of the Chinese instrumental ensemble in <i>Shui.Mo</i>	122
Figure A-49: Bars 141–148, the part of the Chinese instrumental ensemble in <i>Shui.Mo</i>	122
Figure A-50: Bars 100–109, second movement, the part of the Chinese instrumental ensemble in <i>Shui.Mo</i>	123
Figure A-51: First movement, bars 1–7, the opening section of <i>Shui.Mo</i>	123
Figure A-52: First movement, bars 80–87, offstage groups in <i>Shui.Mo</i>	124
Figure A-53: First movement, bars 109–115, offstage groups with onstage Chinese instrument groups in <i>Shui.Mo</i>	124
Figure A-54: Bars 68–73, offstage groups with onstage string groups in <i>Shui.Mo</i>	125
Figure A-55: Second movement, bars 16–22, offstage groups in <i>Shui.Mo</i>	125
Figure A-56: Bars 100–108, second movement, four onstage musicians (percussionists) play four wine glasses in <i>Shui.Mo</i>	126
Figure A-57: Bars 100–108, second movement, four offstage musicians (Ob1/Ob2/Tpt1/Tbn2) play four wine glasses in <i>Shui.Mo</i>	126

Glossary

Bianzhong (編鐘): After the Zhou dynasty (1045-256 B.C.E.), a single bell was called zhong and a set of bells was called bianzhong. The handle was usually at the top, with a ring for suspension. Over the ages, the number of bells in a set eventually increased. Several bell chimes from this period have been unearthed; the set from the tomb of the Marquis Yi of Zeng (Zeng Hou Yi) in Hubei Province in central China is especially well-known. Its date is 433 B.C.E., that is, the early Warring States period. It consists of sixty-four bells suspended on a three-tiered rack. The range is from A1 to c4 in a seven-tone scale, and the middle range of three octaves is in a series of twelve semitones. Each bell can generate two pitches when different parts of it are struck; the two pitches are separated by the interval of a major or minor third.

Provine, R. C., Tokumaru, Y., & Witzleben, L. J. (Eds.). (n.d.). Archaeology and History of Musical Instruments in China. In *Garland Encyclopedia of World Music Volume 7 - East Asia: China, Japan, and Korea* (pp. 143-152). Routledge. Retrieved on May 27, 2016, from Music Online: Garland Encyclopedia of World Music.

Bumiputera: Bumiputera (or Bumiputra) literally means “son(s) of the soil.” This modern Malaysian word was first used in the 1920s and 1930s in the Malay Peninsula. Bumiputera refers to the indigenous people and native communities of Malaysia.

(Ismail, 2004, p. 287)

Dizi (笛子): A transverse bamboo flute with a dimo (membrane hole). Its pitch is regulated through holes along the tube; an additional hole covered with a tissue membrane give the dizi (ti-tzu) its characteristic poignant tone rich in the upper partials.

(“ti-tzu” 1980, p. 275)

Er hu (二胡): The Chinese two-stringed fiddle is played with a bow which is trapped in between the instrument’s two strings.

(Wong, 2005, p. 91).

Hakka (客家): The Hakka people, literally meaning “guest people,” are referred to as being spatially mobile. The Hakka people came from Guangdong and Fujian provinces of China. Large numbers of Hakka migrated to Malaysia and worked as miners in the 19th century. Later, many turned to the rubber industry settled in Kedah and Johor (principally in Kulai and Kluang) as the mining industries declined in the 20th century.

(Hsieh, 1929, p. 202; “Malaysian Chinese,” n.d.)

Hakka mountain song (山歌): “Hakka mountain songs and folk songs play a unique role in traditional performing arts and social culture. During their migrations, Hakka people had always chosen to settle near mountains. Since farming has also been their primary means of livelihood, when they were trailblazing in mountains or working on the farm, their life was always closely related to nature. Mountain songs were created in mountains and open fields. They were improvisations by Hakka forebears while tilling the land or just having fun at leisure. They are mostly depictions of life and praises of love; the emotions of happiness, anger, sorrow and joy are completely expressed in these creations.”

(Hakka Affairs Council, 2006).

Gagaku: Gagaku refers to all traditional court music of Japan. A large number of instruments was used during the Nara period (710-84), but this gradually dwindled to the present range, which become standardized in the mid-19th century, the instruments consists of shōko (gong), tsuridaiko (drum), kakko (barrel drum), two sō-no-koto (zithers), two biwa (lutes), three ryūteki (flutes), three hichiriki (shawms) and three shō (mouth organ).

(Japan, “Gagaku,” 1980, pp. 510, 511)

Gamelan: It is a generic term for various types of orchestra used in Java, Madura, Bali and Malaysia. These orchestras all have the same organization, based on component instrumental groups with specific orchestral functions; they are composed of sets of tuned, single bronze gongs, gong-chimes, single- and multi-octave metallophones, drums, one or more flute, bowed and plucked chordophones, a xylophone, small cymbals and singers.

(Indonesia, “Gamelan,” 1980, p. 173)

Gong Kebyar: This is the most vigorous traditional element of contemporary Balinese musical life. It is the vehicle for almost all the creating energy of Balinese performers and composers, and is the only ensemble with a perceptibly changing repertory.

(Indonesia, “Gamelan gong kebyar,” 1980, p. 182)

Guan zi (管子): The guan zi (kuan-tzu) is double-reed wind instrument. It is generally shorter than the suona (but with the same number and arrangement of finger-holes) and wider in range, managing some two and a half octave. Most guan zi is hardwood, but some are of bamboo or even tin, and they have no bell.

(China, “kuan-tzu,” 1980, p. 275).

Gun (滾) and Lun (輪): “Gun”: Fast paced and continuous plucking of tan and tiao to produce a well rounded sound. This symbol can be written below a note, instead of above it. “Lun”: The forefinger, middle finger, ring finger and last finger flick outwards from right to left in order, while the thumb picks the string from left to right. This is a basic cycle of a lun and the perspective of right and left is from a performer’s viewpoint.

(Wong, 2005, p. 28).

Gu zheng (古箏): The gu zheng is fitted with strings of different length and thickness that are drawn across the long and box-like body of the instrument.

(Wong, 2005, p. 71).

Guqin (古琴) or Ch’in (琴): “A Chinese long zither, one of the family of east Asian zithers that includes the Japanese KOTO, the Korean Komungo and the Vietnamese dan tranh. . . . The Ch’in has seven strings of equal length and varying thicknesses, each being twisted from a fixed number of silk strands. Unlike other Chinese and east Asian zithers, the ch’in has no bridges. Fingers positions are marked along the soundboard by 13 inlaid ivory or mother-of-pearl discs.”

(“Ch’in,” 1980, p. 245).

Koto: The koto is the Japanese member of the family of long zithers with movable frets found in several East Asian countries.

(Japan, “Koto,” 1980, p.526)

Kun Qu (昆曲): Kun Qu is notable in being based on written librettos and in having a system of notation for writing down its music. Its tunes are delicate and slow-moving, with a regular 4/4 rhythm; a single word may be sung over an extended melody. The principal instruments are the ti-tzu and hsiao.

(Chinese transverse and end-blown flutes, “China-Drama-Peking opera,” p. 254).

Nan Yin (南音): Nan Yin, one of China's most ancient music, is an ensemble consisting of singing and instrument playing. Nanyin vocal pieces use the Quanzhou dialect. Pipa (four-string lute), Sanxian (three-string lute), and Paiban (wooden clappers) are the main instruments.

(“Gong,” n.d.)

Noh: A major form of Japanese representative theatre. Noh was established in the late 14th century and early 15th century. Among the Japanese performing arts noh is acknowledgement to have achieved the highest synthesis of literature, theatre, dance and music.

(Japan, “Noh,” 1980, p. 515)

Pansori: "Pansori is a one-man operatic form accompanied by a puk (double headed barrel drum). The singer executes all three elements: aniri (dialogue and narration), pallim (acting) and sori (singing)."

("Korea, 9-Folk music, Pansori," 1980, p. 207).

Peking opera (京劇): Peking opera consists of dialogue sections and singing with orchestral accompaniment, and the two dominating styles, erh-huang (二簧) and hsi-pi (西皮), can be varied endlessly in melody to carry different emotional significance. Er-huang generally occurs in more serious sections, whereas hsi-pi is livelier and merrier.

("China-Drama-Peking opera," p. 257).

Pipa (琵琶): The Chinese pipa has a pear-shaped soundbox and has four strings, traditionally of twisted silk and now often made of nylon.

("P'ip'a," 1980, p. 271)

Pi phat: "The music of Thailand's royal courts owes much to Angkor musical traditions. The Thai ensemble called pi phat is clearly related to its Cambodian cousin; it includes a double-reed wind instrument (pi), xylophones (ranat), gong chimes (khawng), cymbals (ching), and drums (taphon)."

(Spiller, 2004, p. 32).

Rebab: "Javanese, Cirebonese, Balinese, and Sundanese two-string bowed string instrument with two brass strings and a skin-covered resonator."

(Spiller, 2004, p. 284).

Rou Yin (揉音): Every string of gu zheng can produce a note up to a third higher from the string's tuned note when the string is depressed on the left side of the bridge.

(Wong, 2005, p. 79).

Sanxian (三弦): The sanxian (san-hsien) is long-necked lute has an egg-shaped snakeskin-covered soundbox, normally of redwood, and a fretless neck. The musician holds the instrument as he plucks its strings, usually with a plectrum.

("San-hsien," 1980, p. 274).

Sanjo gayageum: The gayageum is one of the Korea's representative string instruments. It consists of a sound box made of paulownia wood and twelve silk strings stretched over movable bridges called anjok. The sanjo gayageum is known to have emerged in the 19th century alongside the rapid development of folk music.

Yi, J. Y. (2011). *Contemporary gayageum notations for composers*. H. S. Kim (Trans.). H. V. Finchun-Sung (Ed.). Seoul: SNU Press. (p. 45).

Serunai: The serunai (shawm) is aerophone family. It is made in two sizes, besar (large) and kecil (small). The Malaysian serunai is derivative of Middle Eastern models, it is particularly characterized by the construction of the reed. Two double layers of dried palm leaf are attached above a pirouette to a metal staple. There are normally seven finger-holes and one thumb-hole.
(“Malaysia, I: West, the Malays, serunai,” 1980, p. 555).

Sheng (笙): The sheng is a free-reed mouth organ, played by blowing through a mouthpiece at the side. Of East Asian origin, it is among the oldest Chinese instruments.
(“sheng,” 1980, p. 277)

Suona (唢呐): The suona (son-na) a is the most wide-spread Chinese double-reed instrument. The main parts of the suona are; the reed, the stem (of cedar wood) and the bell (of copper); there are eight holes holes in the stem for determining pitch, seven finger holes and one thumb hole.
(China, “So-na,” 1980, p. 276).

Tui (推) and La (拉): “Tui”: Left finger pressing the string pushes inwards along a fret to raise the sound that the string produces. “La”: Left finger pressing the string pulls outwards along a fret to raise the sound that the string produces.
(Wong, 2005, p. 29).

Wayang kulit: The shadow-puppet theatre, wayang kulit, is a form of entertainment particularly popular in the Indonesia and Malaysia. The dalang (puppeteer) uses conversational and dramatic tones of voice and song joining with the instrumental music as an integral part of the action. The stories are based on the Ramayana epic and are told completely in the local dialect. The musical ensemble consists of one serunai (shawm), three pair of drums, geduk, gendang (barrel drum) and gedumbak (goblet drum), each in the two sizes known as ibu and anak, one set of canang (small gongs), one pair of kesi, and tetawak.
(“Malaysia, I: West, the Malays, wayang kulit,” 1980, p. 599).

Xiao (簫): The end-blown flute xiao (Hsiao) is also of bamboo, but unlike dizi, it has no membrane-covered aperture. There are seven side holes, of which six function as pitch determinants; the mouth-hole at the top takes up only part of the total end area, most of which is closed off.
(“Hsiao” 1980, p. 276)

Xun (埙): The xun is a vessel flute in the shape of an egg, a tube, or a ball. All xun of the Neolithic were made of pottery, so they are also called taoxun 'pottery xun'. The earliest xun, dating from about 5000 B.C.E., was unearthed at the Hemudu site. It is egg-shaped and has a mouth hole but no finger holes. Neolithic xun were also unearthed in Shaanxi, Shanxi, Gansu, Shandong, and Jiangsu provinces. These are in various shapes and have a mouth hole and one to three finger holes. Among them, twenty xun found at the Huoshaoguo site in Gansu Province in northwestern China.

Provine, R. C., Tokumaru, Y., & Witzleben, L. J. (Eds.). (n.d.). Archaeology and History of Musical Instruments in China. In *Garland Encyclopedia of World Music Volume 7 - East Asia: China, Japan, and Korea* (pp. 143–152). Routledge. Retrieved on May 27, 2016, from Music Online: Garland Encyclopedia of World Music.

Yang qin (揚琴): This dulcimer was introduced into China during the Ming dynasty (1368-1644). The yang qin (Yang-ch'in) is very similar to the European dulcimer; the two instruments appear to have originated in the same place and clearly related. It has the shape of the trapezium. Strings in sets, decreasing in the length towards the top (shortest side) of the instrument, are stretched over one of the two bridges to the left and right of the centre, and through a hole in the other. The player strikes the strings with light bamboo sticks.

(China, "Yang ch'in," 1980, p. 275).

Portfolio of compositions

The portfolio contains six original compositions:

01.

Composition title:

水。墨 *Shui.Mo* (Water.Ink)

Instrumentation:

Concerto for 4 Chinese instruments (Traditional 37-reed soprano sheng, erhu, pipa and gu zheng) with Western symphony orchestra

Traditional 37-reed Sheng+Erhu+Pipa+GuZheng+2.2.2.2-4.2.2.1-timp-perc(3)-cel-hrp-str(18.0.6.6.4)

Year of composition:

2008

Duration:

19'53"

Performed by:

Soloists of Dragon Ensemble (Berlin/Germany) [Traditional 37-reed soprano sheng: Wu Wei, Erhu: Zhang ZhenFang, Pipa: Dong Ya, Gu Zheng: Xu Feng Xia] and Symfonie Orkest Vlaanderen (Brugge/Belgium) under the baton of Mr. Janus Alber

02.

Composition title:

別歌 *Bie Ke* (Song of farewell)

Instrumentation:

For boy soprano, traditional soprano sheng, choir in 4 groups and 6 percussionists

Year of composition:

2012

Duration:

14'24"

Performed by:

Hsu Bor-Nien and Chen Yun-Hung, Conductor

Huang Lung-Yi, traditional 24-reed soprano Sheng

Forum Music Ensemble (Taipei/Taiwan) and Taipei Chamber Singers (Taipei/Taiwan)

03.**Composition title:**

尋風 *Xun Feng* (Seeking the wind)

Instrumentation:

Concerto for 4 Chinese instruments (Pipa, Gu zheng, Dizi/Xiao & traditional 37-reed soprano Sheng) and Chinese orchestra.

Pipa+GuZheng+Dizi/Xiao+ traditional 37-reed soprano Sheng + Gsh, Zsh. Dsh. Yq. I, Yq. II, Gz.I, Gz. II, Lq. Pp., Zhr, Dr. Gs. Zs. Ds. 2Bd., Xd, Gh, Eh.I, Eh.II, Zh., Vc., Db.

Year of composition:

2013

Duration:

17'28"

Performed by:

Soloists of Chai Found Music Workshop [traditional 37-reed soprano Sheng: HUANG Lung-Yi, Dizi/Xiao: WU Chung-Hsien, Pipa: LIN Hui Kuan, Gu Zheng: Yeh Jiuan-Reng] and Chai Found Music Workshop Chinese Orchestra (Taipei/Taiwan) under the baton of Mr. HUANG Chen-Ming

04.**Composition title:**

雲湧 *Yun Yong* (Clouds Surging)

Instrumentation:

String quartet

Year of composition:

2011

Duration:

17'

Performed by:

Momenta Quartet (New York/USA)

05.**Composition title:**

Timeless echoes

Instrumentation:

Cello solo, live performer on painting (video projection) and live electronics

Year of composition:

2010/2011

Duration:

18'19"

Performed by:

Cellist Arne Deforce and painter Sirgid Tanghe, live electronics by Jean Marc Sullon and Patrick Delges from the Center Henri Pousseur

06.

Composition title:

源一流 *Yuan-Liu* (Origin-Stream)

Instrumentation:

Traditional 37-reed soprano sheng, 2 pianos and 2 percussionists

Year of composition:

2009

Duration:

11'28"

Performed by:

WU Wei, traditional 37-reed soprano sheng

Ensemble Berlin PianoPercussion (Berlin/Germany):

Prodromos Symeonidis – piano; Sawami Kiyoshi – piano; Adam Weisman – percussion;

Friedemann Werzlau – percussion

Ya-ou Xie, conductor

The portfolio is supplied with two compact discs entitled “Selected works (1) & (2) by CHONG Kee Yong which contains recordings of all the compositions detailed above. A DVD is attached as well, which contains the software package and performance video of *Timeless echoes*.

Accompanying compact discs: Track details

01. *Shui.Mo*

CD1 – track 4 of the selected works (1) by CHONG Kee Yong

- 4] ~ “*Shui.Mo*” (Water.Ink) (2007)-----[19:53]
Concerto for 4 Chinese instruments and Western symphony orchestra
“水。墨”為四件中國樂器和西洋管弦樂團之協奏曲
1st Movement: 水紋 “Shui Wen” (Ripples of water)
--Dedicated to Prof. CHUO Wen Chung--
2nd Movement: 墨韻 “Mo Yun” (Charm of the ink)
--In memory of YUN Isang--
Dragon Ensemble:
WU Wei, traditional 37-reed soprano sheng; DONG Ya, pipa; ZHANG Zhen Fang, erhu;
XU Feng Xia, gu zheng
Symfonie Orkest Vlaanderen
Jonas Alber, conductor
World premiere concert recording: 15 January 2008
Venue: Concertgebouw Bruges (Belgium)

02. *Bie Ge*

CD2 –track 4 of the selected works (2) by CHONG Kee Yong

- 4] ~ “*Bie Ge*” (Song of farewell) (2012)-----[14:24]
for boy soprano, soprano sheng, choir in 4 groups and 6 percussionists
“別歌”為男聲女高音，傳統 24 簧高音笙，四組合唱團和六位打擊樂手而作
--Dedicated to HSU Bor-Nien, CHEN Yun-Hung, HUANG Lung-Yi, the Forum Music
Percussion Ensemble and the Taipei Chamber Singers--
--Commemorating the countless, unknown warriors in history who have sacrificed
their lives for peace.
CHEN Mu-Qi, boy soprano
HUANG Lung-Yi, traditional 24-reed soprano sheng
Forum Music Percussion Ensemble:
HUANG Li-Ya, CHIA Wen-Hao, SUEN Ming-Jen, WANG Ya-Ting, HUANG Ya-Lin and
HUANG Hsiu-Tan
Taipei Chamber Singers
HSU Bor-Nien, conductor (Percussion ensemble)
CHEN Yun-Hung, conductor (Choir)
World premiere concert recording: 29 November 2012
Venue: Zhong Shan concert hall (Taipei, Taiwan)

03. *Xun Feng*

CD1 – track 6 of the selected works (1) by CHONG Kee Yong

- 6] ~ “*Xun Feng*” (Seeking the wind) (2013)-----[17:28]
Concerto for 4 Chinese instruments and Chinese Orchestra
“尋風”為四件中國樂器和中國國樂團之協奏曲
--Dedicated to HUANG Chen-Ming, LIN Hui-Kuan, YEH Jiuan-Reng, WU Chung-Hsien, HUANG
Lung-Yi and the Chai Found Music Workshop--
--In memory of my beloved mentor Prof. RAO Yu Yan--
LIN Hui-Kuan, pipa; YEH Jiuan-Reng, gu zheng; WU Chung-Hsien, dizi/xiao; HUANG
Lung-Yi, traditional 37-reed soprano sheng
Chai Found Music Workshop Orchestra

HUANG Chen-Ming, conductor
World premiere concert recording: 06 March 2013
Venue: Taiwan National concert Hall (Taipei, Taiwan)

04. Yun Yong

CD2 – track 3 of the selected works (2) by CHONG Kee Yong

- 3] ~ “Yun Yong” (Clouds surging) (2011)-----[17:00]
String Quartet no.4
“雲湧”第四號弦樂四重奏
--For the Serge Koussevitzky Music Foundation in the Library of Congress and
dedicated to the memory of Serge & Natalie Koussevitzky--
Specially written for the Momenta Quartet:
Emilie-Anne Gendron, violin; Adda Kridler, violin; Stephanie Griffin, viola; Michael
Haas, cello
Concert recording: 8 November 2012
Venue: Freer Gallery of Art in Washington D.C. (USA)

05. Timeless echoes

CD2 – track 5 of the selected works (2) by CHONG Kee Yong

- 5] ~ “Timeless echoes” (2010/2011)-----[18:19]
for cello solo, live electronics and projection video of live painting
“永恆的迴響”為大提琴獨奏，現場電子音樂互動和現場繪畫投影視頻而作
--Dedicated to Arne Deforce, Sigrid Tanghe & the Centre Henri Pousseur--
--In memory of Mr. MO Wu Ping, a composer I have never met, but respect highly!
Arne Deforce, cello
Jean Marc Sullon and Mr. Patrick Delges (Centre Henri Pousseur), live electronics
World premiere concert recording: 19 November 2011
Venue: Église Saint-André (Liège, Belgium)

06. Yuan-Liu

CD1 – track 3 of the selected works (1) by CHONG Kee Yong

- 3] ~ “Yuan-Liu” (Origin-Stream) (2009)-----[11:28]
for traditional 37-reed soprano sheng, 2 pianos and 2 percussionists
“源一流”為傳統 37 簧高音笙，雙鋼琴與雙打擊樂而作
--Dedicated to Wu Wei & Ensemble Berlin PianoPercussion--
WU Wei, traditional 37-reed descant sheng
Ensemble Berlin PianoPercussion
Prodromos Symeonidis – piano; Sawami Kiyoshi – piano; Adam Weisman –
percussion; Friedemann Werzlau – percussion
Ya-ou Xie, conductor
Concert recording: 10 February 2010
Venue: Konzerthaus Berlin (Germany)

Supporting materials to Chapter III & Appendix A

(Please refer to the memory stick)

Selected 8 scores in pdf-file and the recordings in mp3 format:

01. Temple bell still ringing in my heart (2002) for viola solo
Yoshiko HANNYA, viola

02. Liu-xu-fei (2001) for oboe and cello
Rafeal Palacios, oboe
Stijn Kuppens, cello

03. Metamorphosis I (2000, revised 2007) for viola and harp
Stephanie Griffin, viola
Jacqui Kerrod, harp

04. Wu Yan (2003, revised 2013) for 6 percussionists
Forum Music percussion ensemble:
HUANG Li-Ya, WU Jui-Tsung, YU Tan-Ling, WANG Ya-Ting, HUANG Ya-Lin and HUANG Hsiu-Tan
HSU Bor-Nien, conductor

05. Metamorphosis VI - Wind prayer-(2005) for three Chinese instruments (pipa, gu zheng and 37-reed soprano sheng and 10 Western instruments
WU Wei, traditional 37-reed soprano sheng; pipa; XU Feng Xia, gu zheng
Nieuw Ensemble
Ed Spanjaard, Conductor

06. Endless whispering (2006) for 37-reed soprano sheng (also Xun) and four western instruments with live electronics
WU Wei, traditional 37-reed soprano sheng
KNM Berlin's Ganesha
Andre Bartetzki, live electronics (Akademie der Kunste, Berlin)

07. Horizon's chant (2007) for for 37-reed soprano Sheng, gayageum and koto
WU Wei, traditional 37-reed soprano sheng
Jocelyn Clark, 12-string sanjo gayageum
Ryuko Mizutani, 13-string koto

08. Yuan-He (2010) Concerto for five Chinese instruments and five western instruments
Dragon Ensemble:
FU Reng Chang, yang qin and leader; WU Wei, traditional 37-reed soprano sheng; XU Feng Xia, gu zheng; WANG Hong, dizi/quan zi/xun; YAN Jie Min, erhu
Ensemble Het Collectief:
Toon Fret, Flute; Benjamin Dieltjens, clarinet/bass clarinet; Thomas Dieltjens, piano; Wibert Aerts, violin; Martijn Vink, cello

Biography

CHONG Kee Yong, one of Malaysia's leading contemporary music composers, possesses one of the most exciting voices in music today. His work has been hailed as "imaginative and poetic" by conductor-composer Peter Eötvös, and as "inventive and artistically pure" by composer Jonathan Harvey. The uniqueness of his music stems not only from a rich palette of sounds, but his experimentation with traditions, infusing his own Chinese and multi-cultural Malaysian heritage with his work.

Chong was born in Kluang, Johor, where his parents were farmers. He graduated from the Malaysian Institute of Arts in Kuala Lumpur and completed his Bachelor of Arts at the Xian Conservatory with Prof Rao Yu Yan and Prof Zhang Da Long. Professor Rao recommended that Chong pursue his final studies at the Royal Conservatory of Music of Brussels (Flemish & French sections) under the guidance of Prof Jan Van Landeghem and Prof Daniel Capelletti. There he acquired the tools for his compositional style, which are a delightful balance between cutting-edge modern techniques and a deep sense of poetic beauty.

In 2001, Chong graduated as Master of Composition with highest honours. His postgraduate studies include numerous master classes with composers such as Brian Ferneyhough, Daan Manneke, Zoltan Janey, Peter Eötvös, Salvatore Sciarrino, Henri Pousseur, and Hanspeter Kyburz.

Chong's distinctive style has won him many awards and commissions. His list of prizes at various competitions is remarkable, for example the Prix Marcel Hastir by Belgium Royal Academy of Sciences, Letters & Fine-arts (1999, 2003), the 4th International Andrzej Panufnik Competition for Young Composers in Poland (2002), the Grand Prix at the 2nd Seoul International Competition for Composers (2003), the Max-Reger-Tage International Composition Competition in Germany (2004), the Malaysian Philharmonic Orchestra International Composers' Award (2004), second prize at the 2nd Lepo Sumera International Young Composer Prize (2006), Lutoslawski Award (2006), BMW Award in the International Isang Yun Music Prize in Korea (2007), 2nd prize in the Preisträgerkonzert des Internationalen Kompositionswettbewerbes "global music—contemporary expression" in Germany, 3rd prize in Luxembourg International Composition Award 2008 and Giga-Hertz-Award 2009 (Germany).

He has been awarded the composer-in-residency with Akademie der Künste (Germany), Herrenhaus Edenkoben (Germany), Asian Cultural Council (USA), the Center Henri Pousseur (Belgium), SWR EXPERIMENTALSTUDIO (Germany), Civitella Ranieri Foundation Fellowship 2014 (USA/Italy) and 2015 National Gugak Center Fellowship (Korea).

He is the first Malaysian composer received the prestigious commission grant award by the Serge Koussevitzky Music Foundation (USA) and the prestigious "The Outstanding Young Malaysian Awards" in the Cultural Achievement category.

Chong is the creative director of Studio C, vice president of the Society of Malaysian Contemporary Composers (2011-present), and was the artistic director of the 2009 Kuala Lumpur Contemporary Music Festival and SMCC Contemporary Music Festival "SoundBridge" 2013 and 2015.

His website is www.chongkeeyong.com

Complete list of compositions (2010–2015)

The following list documents all musical work composed within the period stated above and not the contents of the accompanying folio (which itself is described portfolio).

More information about these works can be found at:

www.chongkeeyong.com

1.

Shadow Chanting for alto saxophone and live electronics

Composed: June 2015

Commissioned by: Shyen Lee

Dedication: Shyen Lee

Duration: ca 8'

World premiere: 10 June 2015

Venue: Bangkok Art & Culture Center (Thailand)

1st Performed by: Shyen Lee (Saxophone), Pradit Saengkrai (Live electronics)

2.

湧現的四季 (Streams of four seasons) for four groups of gu zheng, da ruan, double bass and 2 percussionists

Composed: April 2015

Commissioned by: Hangzhou Fei Chui Guzheng ensemble (China)

Dedication: In memory of WU Guanzhong

Duration: ca 11'

World premiere: 31 May 2015

Venue: Concert hall of College of Music, Hangzhou Normal University (China)

1st Performed by: Hangzhou Fei Chui Guzheng ensemble (China) and Zhou Jan (conductor)

3.

Horizon's chants II for Gayageum, Koto and String trio

(Original version 2007 is for Sheng, Gayageum and Koto)

Composed: March 2015

Commissioned by: AsianArt Ensemble (Berlin/Germnay)

Duration: ca 16'20"

World premiere: 8 April 2015, concert of "Focused Asian Chants"

Venue: Konzerthaus: Werner-Otto-Saal (Berlin/Germany)

1st Performed by: AsianArt Ensemble (Berlin/Germnay)

4.

Surging on woods for two 5 octaves marimbas

-After J.S Bach's two part Invention of No.3 in D major-

Composed: November 2014

Commissioned by: Music Forum Ensemble (Taiwan)

Dedication: Music Forum Ensemble (Taiwan)

Duration: ca 3'

World premiere: 28 December 2014

Venue: Auditorium of Music (Taipei/Taiwan)

1st Performed by: Music Forum Ensemble (Taiwan)

5.

影子。戲歌 Wayang-Lagu [Shadow. Song for the drama] for large mixed choir A cappella with 4 wine glasses players

Composed: October 2014

Commissioned by: Taipei Chamber Singers (Taiwan)

Dedication: CHEN Yun-Hung and Taipei Chamber Singers

Duration: ca 20'

World premiere: 29 December 2014, Music unlimited program VII

Venue: Zhong Shan concert hall (Taipei/Taiwan)

1st Performed by: Taipei Chamber Singers (Taiwan) and CHEN Yun-Hung (Conductor)

6.

Hover in the Horizon version for violin solo and live electronics

Composed: September 2014

Commissioned by: Wibert Aerts

Dedication: Wibert Aerts

Duration: ca 12'

World premiere: 8 November 2014, the Festival Images sonores #16 (Liege/Belgium)

Venue: Théâtre de Liège (Belgium)

1st Performed by: Wibert Aerts (Violin) and live electronics by Jean Marc Sullon from the Center Henri Pousseur

7.

Endless echo from the ancient land for alto flute or any melody instrument, 4 crystal glasses and pre-recorded sound sample

After listening to ancient Shakuhachi ancient piece "Jimbo-Sanya" played by Yoshida Koichi..

Composed: July 2014

Commissioned by: Civitella Ranieri Foundation

Dedication: the Civitella Ranieri Foundation and its director Dana Prescott, staff and fellows (Group2_June-July)

Duration: 8'30"

World premiere: 14 July 2014

Venue: Auditorium of Civitella Ranieri Foundation (Umbertide, Italy)

1st Performed by: Valerio Fasoli (alto flute), Crystal wine glass: Eric Wubbels, Alexandre Lunsqui, Sergio de Regules, CHONG Kee Yong and Studio C (live electronics)

8.

靜心。花海 (*Jing Xin.Hua Hai*) [Peaceful heart. Ocean of flowers] for traditional 37-reed soprano sheng solo

Composed: June 2014

Commissioned by: WU Wei

Dedication: WU Wei

Duration: ca. 13'

World premiere: 25 June 2014

Venue: Båstad Chamber music festival (Sweden)

1st Performed by: WU Wei (traditional 37-reed soprano sheng)

9.

源。飛 (二) *Yuan-Fei II* [Origin-Fly] version for shakuhachi, flute, clarinet (also bass Clarinet), viola, cello, percussion and piano

Composed: May 2014

Commissioned by: HERMES ensemble (Belgium)

Dedication: Koen Kessels and HERMES ensemble (Belgium)

Duration: ca 9'

World premiere: 20 Jan 2015, KEE YONG CHONG's portrait concert

Venue: Het Kanaal – Wijnegem (Belgium)

1st Performed by: Koichi Yoshida (Shakuhachi), HERMES ensemble and Koen Kessels (Conductor)

10.

Fantasy on tearless moon for orchestra

Composed: April 2014

Commissioned by: Malaysian Philharmonic Youth Orchestra

Dedication: Kevin FIELD and in memory of Geraldine MCDONNELL, and To mourn the lost and salute to our nation hero Mr. Karpal Singh (1940-2014) who defended the freedom of a nation!

Duration: ca 19'

World premiere: 13 June 2014

Venue: Dewan Petronas concert hall (Kuala Lumpur/Malaysia)

Performed by: Malaysian Philharmonic Youth Orchestra and Kevin Field (Conductor)

11.

Music for JIMI version for 6 percussionists and pre-recorded sound samples

Composed: March 2014

Commissioned by: Music Forum Ensemble (Taiwan)

Dedication: HSU Bor Nien

Duration: ca 8'

World premiere: 31 May 2014, the 8th Taipei International Percussion Convention (Taiwan)

Venue: Taiwan National Concert Hall (Taipei/Taiwan)

1st Performed by: Music Forum Ensemble (Taiwan)

12.

Music for JIMI original version for 3 percussionists and pre-recorded sound samples

Composed: November 2013, rev. August 2015

Commissioned by: Music Forum Ensemble (Taiwan)

Dedication: HSU Bor Nien

Duration: ca 8'

World premiere: 2 December 2013

Venue: Novel Hall (Taipei, Taiwan)

1st Performed by: Forum Music Ensemble (Taiwan)

13.

Phoenix calling revised version for traditional 37-reed soprano sheng and ensemble (Fl/Ob/Cl/Vln/Vla/Vc/Pno/Perc)

Composed: October 2013

Commissioned by: Goethe Institut Young composers competition and workshop festival 2013.

Dedication: WU Wei and in memorial of the victims of tragedy in Sichuan and Myanmar.

Duration: ca 14'

World premiere: 14 December 2013

Venue: Sangkeet Vadhana Hall, Princess Galyani Vadhana Institute of Music (Bangkok/Thailand)

1st Performed by: WU Wei (Sheng), Ensemble Mosaik, Enno Poppe (Conductor)

14.

驚鴻 (Jing Hong) [Glimpse] for flute, clarinet, violin, cello and percussion

Composed: October 2013

Commissioned by: Asian New Music Ensemble (Shanghai/China)

Dedication: Asian New Music Ensemble

Duration: ca 8'30"

World premiere: 17 December 2013

Venue: He Luting Concert Hall of Shanghai Conservatory of Music (China)

1st Performed by: Asian New Music Ensemble (Shanghai/China) and Kee Yong CHONG (conductor)

15.

Time flows III for piano solo, video projection, live electronic and 3 off stage musicians (Viola, flute and percussion)

Composed: September 2013

Commissioned by: SMCC's "SoundBridge 2013"

Dedication: Thor Hong Chuan

Duration: ca 12'

World premiere: 5 October 2013

Venue: (Kuala Lumpur/Malaysia)

1st Performed by: Nicholas ONG (Piano), Daisuke Kinoshita (Flute), Saori (Violin) Max Reifer (Percussion) and Studio C, YEO Chow Shern (live electronics)

16.

尋風 *Xun Feng* (Seeking the wind) Concerto for 4 Chinese instruments (Pipa, Gu Zheng, Dizi/Xiao and traditional 37-reed soprano Sheng) and Western symphony orchestra

Composed: July 2013

Commissioned by: Philharmonia Moments Musicaux

Dedication: CHIANG Ching Po, LIN Hui Kuan, YEH Jiuan-Reng, WU Chung-Hsien, HUANG Lung-Yi, and in memory of my beloved mentor Prof. RAO Yu Yan

Duration: ca 19'

World premiere: 28 December 2013, Philharmonia Moments Musicaux's year-end concert 2013

Venue: Taiwan National Concert hall (Taipei/Taiwan)

Performed by:

LIN Hui Kuan (Pipa), YEH Jiuan-Reng (Gu zheng), WU Chung-Hsien (Dizi/Xiao), HUANG Lung-Yi (Sheng), Philharmonia Moments Musicaux and Paul Chiang Ching Po (Conductor)

17.

客。情 (*Hak.Qin*) [Hakka. Love] Concerto for sanxian/gu zheng/voice and Chinese orchestra with pre-recorded sound samples

Composed: March-April 2013

Commissioned by: Singapore Chinese Orchestra

Dedication: Xu Feng Xia and maestro Yeh Tsung, in memory of my beloved late maternal grandfather Hakka storyteller/mountain song singer maestro Sak--

Duration: ca 29'

World premiere: 10 Oct 2013

Venue: Singapore Conference hall (Singapore)

1st Performed by: XU Feng Xia (sanxian/gu zheng/voice), Singapore Chinese Orchestra, maestro YEH Tsung (Conductor) and team of Studio C, Yeo Chow Shern and Chow Jun Yan (Sound projection)

18.

心。吟 (*Xin.Yin*) [Heart. Chanting] for guqin, pipa, percussion, acting drummer and pre-recorded sound samples

Composed: March 2013

Commissioned by: LIN Hui Kuan

Dedication: TUNG Chao Ming, LIN Hui Kuan, WANG Xiao Yin & Alex CHEUNG Wai Yuen

Duration: ca 10'

World premiere: 13 April 2013

Venue: Zhong Shan Concert Hall (Taipei/Taiwan)

1st Performed by: Tung Chao Ming (quqin), Lin Hui Kuan (pipa), Wang Xiao Yin (percussion), Alex Cheung Wai Yuen (actor/drummer) and Studio C, Yeo Chow Shern (Live electronics)

19.

Ocean of tears for bass flute solo

(After listening to *PATANGIS-BUWAYA* by Prof. Jonas Baes)

Dedicated to my composer friend Prof. Jonas Baes

Composed: February 2013

Commissioned by: Daisuke Kinoshita

Dedication: Jonas Baes

Duration: ca 8'

World premiere: 26 February 2013

Venue: Kanazawa (Japan)

1st Performed by: Daisuke Kinoshita (Bass flute)

20.

尋風 *Xun Feng* (Seeking the wind) Concerto for 4 Chinese instruments (pipa, gu zheng, dizi/xiao and traditional 37-reed soprano sheng) and Chinese orchestra.

Composed: January-February 2013

Commissioned by: Chai Found Music Workshop (Taiwan)

Dedication: HUANG Chen-Ming, LIN Hui Kuan, Yeh Jiuan-Reng, WU Chung-Hsien, HUANG Lung-Yi and Chai Found Music Workshop; in memory of my beloved mentor Prof. Rao Yu Yan

Duration: ca 17'30"

World Premiere: 06 March 2013

Venue: Taiwan National Concert hall (Taipei, Taiwan)

1st Performed by: Soloists of Chai Found Music Workshop (Taiwan) [Sheng: HUANG Lung-Yi, Dizi/Xiao: WU Chung-Hsien, Pipa: LIN Hui Kuan, Gu Zheng: Yeh Jiuan-Reng], Chai Found Music Workshop Chinese Orchestra and HUANG Chen-Ming (Conductor)

21.

別歌 *Bie Ke* (Song of farewell) for boy soprano, traditional soprano 24-reed sheng, choir in 4 groups and 6 percussionists

Composed: September-October 2012

Commissioned by: Music Forum Ensemble (Taiwan)

Dedication: Hsu Bor-Nien, Chen Yun-Hung, Huang Lung-Yi, Forum Music Ensemble and Taipei Chamber Singers-Commemorate the history of countless unknown soldiers for peace sacrifice—

Duration: ca 14'30"

World premiere: 29 November 2012

Venue: Zhong Shan Concert hall (Taipei, Taiwan)

1st Performed by: HSU Bor-Nien (Conductor), CHEN Yun-Hung (Conductor), Huang Lung-Yi (traditional 24-reed soprano sheng), Forum Music Ensemble and Taipei Chamber Singers

22.

無為。夢蝶 (*Wu Wei. Meng Die*) [For nothingness. Butterfly dream] for traditional 37-reed soprano sheng (also Xun/Voice), bass Clarinet, live electronics improviser and live electronics

Composed: July 2012

Commissioned by: SWR ExperimentalStudio (Germany)

World premiered: 26 August 2012

Venue: Conservatorium van Amsterdam (Haitinkzaal)

Dedication: WU Wei, Harry Sparnaay, Reinhold Braig, Thomas Hummel and ExperimentalStudio des SWR

1st Performed by: by WU Wei (Sheng/Voice/Xun); Bass clarinet (Harry Sparnaay), electronic performers (Reinhold Braig and Thomas Hummel) and ExperimentalStudio des SWR (Simon Spillner)

23.

Threnody of the mother of earth for version flute solo

Composed: June 2012

Commissioned by: "mmm... 's Hibari" Charity Project

Dedication: In the memory of the victims of the earthquake and Tsunami in Japan 11th March 2011

Duration: ca 6'

World premiere: 26 April 2012

Venue: Studio recording version

1st Performed by: Reiko Manabe (Flute)

24.

Ocean waves for ensemble (Fl/Cl/Ob/Perc/Pno/Vln/Vla/Vc)

Composed: September 2011

Commissioned by: Goethe Institut South East Asia Young Composers Competition & Festival 2011 Bandung

Dedication: Ensemble Mosaik (Berlin/Germany)

Duration: ca 10'

World premiere: 2 October 2011

Venue: Taman Budaya (Bandung, Indonesia)

1st Performed by: Ensemble Mosaik and Robert HP Platz (Conductor)

25.

Hover in the Horizon version for violin solo

Composed: June 2011

Commissioned by: Wibert Aerts

Dedication: Wibert Aerts

Duration: ca 12'

World premiere: 5 July 2011

Venue: KL Performing Arts Center (Kuala Lumpur/Malaysia)

1st Performed by: FUNG Chern Hwei (Violin)

26.

Bell stone for percussion solo

Composed: April 2011

Commissioned by: HUANG AiYun

Dedication: HUANG AiYun

Duration: ca 11'

World premiere: 8 May 2011, concert of "Malaysian Voices II"

Venue: The Music Gallery (Toronto/Canada)

1st Performed by: HUANG AiYun (Percussion)

27.

雲湧 Yun Yong (Clouds Surging) for string quartet

Composed: March 2011

Commissioned by: Serge Koussevitzky Music Foundation for Momenta Quartet.

Dedication: ca 17'

This work is for the Serge Koussevitzky Music Foundation in the Library of Congress, and dedicated to the memory of Serge and Natalie Koussevitzky.

World Premiere: 13 May 2011

Venue: The Museum of Chinese in America (New York/USA)

1st Performed by: Momenta Quartet (New York/USA)

28.

Threnody to the mother of earth for flute solo and 11 musicians (Fl. Solo/ Fl/Ob/Cl/2

Perc/pno/VlnI/Vln.II/Vla/Vc/Db)

Composed: March 2011

Commissioned by: New music concerts ensemble (Toronto/Canada)

Dedication: Robert Aitken and in memorial of the victims of the earthquake/ tsunami in Japan 11th March 2011

Duration: ca 18'

World premiere: 8 May 2011, concert of "Malaysian Voices II"

Venue: The Music Gallery (Toronto/Canada)

1st Performed by: Robert Aitken, new music concerts ensemble (Toronto/Canada) and CHONG Kee Yong (Conductor)

29.

Time flow II for Piano and live electronics

Composed: February 2011

Commissioned by: Jen Chen Hui and Jacob David Sudol

Dedication: Jen Chen Hui and Jacob David Sudol

Duration: ca 11'

World premiere: 8 March 2011, concert of "A Poetic Space filled with the Natural and the Imagined –Music for Piano and Electronic Sound"

Venue: National Chiao Tung University Arts Center (Taiwan)

1st Performed by: Jen Chen Hui (Piano) and Jacob David Sudol (Live electronics)

30.

Echoes for cello and piano

Composed: June 2011

Commissioned by: ensemble cross.art (Stuttgart / Germany)

Dedication: "cross.art 400" project

Duration: ca 0'20"

World premiere: 20 October 2011

Venue: open art space (Stuttgart/Germnay)

Performed by: Junko Yamamoto (piano) and Celine Papion (Cello) of ensemble cross.art

31.

Untitled love for bass clarinet and percussion

Composed: 2011

Commissioned by: Asian Young Musicians' Connection.

Dedication: Duplum Duo

Duration: ca 12'

World premiere: 3 June 2011, the second annual concert "A Confluence of Cultures: Music of the Pacific Rim"

Venue: California State University, San Bernardino (USA)

1st Performed by: Duplum Duo

32.

風動 Feng Dong [Movement of wind] for flute and piano

Composed: May 2011, revised March 2012

Commissioned by: A CONFLUENCE OF CULTURES: Echoes from the Pacific Rim Project

Dedication: ZAO Wou Ki

Duration: ca 13'

World premiere: 1 March 2011, concert of "The Night of New Music – a confluence of cultures: echoes from the Pacific Rim"

Venue: Taiwan Nation Recital Concert hall (Taipei/Taiwan)

Performed by: Glendy Chien (Flute) and Cha-Lin Liu (Piano)

33.

Ancient calling (b) Version for Trombone solo and pre-recorded sound sample

Composed: February 2011

Commissioned by: Dirk Amrein

Dedication: Dirk Amrein

Duration: ca 10'

World premiere: 17 February 2011

Venue: Dampfzentrale (Bern/Switzerland)

Performed by: Dirk Amrein (Trombone)

34.

Metamorphosis IIb --Chant of snow river --version for Flute in C [piccolo/alto flute and 4 gongs] and percussion with 2 off stage alto saxophones

Composed: January 2011

Commissioned by: Manila Composers'net

Dedication: LIU Zong-Yuan

Duration: ca 12'

World premiere: 11 March 2011, concert of Manila Composers'net (Manila/Philippine)

Venue: Aberlado hall of University Philippine (Manila/Philippine)

Performed by: Ensemble Selisih (Germany)

35.

Timeless echoes for cello solo, live electronics and projection video of live painting

Composed: October 2010

Commissioned by: Centre Henri Pousseur (Liège/Belgium)

Dedication: Arne Deforce, Sirgid Tanghe and Centre Henri Pousseur (Liege/Belgium), and In memory of Mr. MO Wu Ping, a composer I have never met, but respect highly!

Duration: ca 19'

World premiere: 19 November 2011 in the "Images Sonores" Festival

Venue: Église: Saint-André Liège, Belgium)

1st Performed by: Arne Deforce (Cello), Sirgid Tanghe (Visual painting and projection), live electronics by Jean Marc Sullon and Patrick Delges from the Center Henri Pousseur

36.

Ancient calling for trombone, piano and pre-recorded sound sample

Composed: June 2010

Commissioned by: Dirk Amrein and Jand Henneberger

Dedication: Dirk Amrein and Jand Henneberger

Duration:

World premiere: 15 July 2010, Thailand International Composers Festival 2010 (TICF)

Venue: the auditorium hall of Rangsit University

Performed by: Dirk Amrein (Trombone) and Jand Henneberger (Piano)

37.

Temple bell still ringing in my heart version for Shakuhachi solo

Composed: May 2010

Commissioned by: Andrew MacGregor

Dedication: Andrew MacGregor and in memory of Madame FUJII Kazuko

Duration: ca 4'

World premiere: 16 June 2010.

Venue: SEGi College Subang (Malaysia)

1st Performed by: Andrew MacGregor

38.

Hover in the horizon for violin solo pre-recorded sound sample

Composed: March 2010

Commissioned by: deSingel (Antwerp/Belgium)

Dedication: Wibert Aerts

Duration: ca 8'

World premiere: 13 March 2010, Wibert Aertstc debut concert at Ars Musica Festival 2010 (Belgium)

Venue: deSingel concert hall (Antwerp, Belgium)

1st Performed by: Wibert Aerts (Violin), Jean-Marc Sullon from Centre Henri Pousseur

39.

源和 Yuan-He (Origin-Harmony) concerto for five Chinese (Dizi/GuanZi/Xun, Sheng, Guzheng, Yanqin, Erhu) and five Western (Fl/Cl/Vln/Vc/Pno) instruments

Composed: January 2010

Commissioned by: Het Collectief Ensemble (Belgium)

Dedication: Dedication: Dragon Ensemble (Germay) & Het Collectief ensemble (Belgium)

Duration: ca 12'

World premiere: 27 Jan 2010, "7 Jan 2010Sound Flowing" project

Venue: deSingel concert hall (Antwerp, Belgium)

1st Performed by: Dragon Ensemble (Germay) & Het Collectief ensemble (Belgium)