



University of HUDDERSFIELD

University of Huddersfield Repository

Grossoni, Ilaria and Bezin, Yann

The influence of support conditions on short- and long-term track behaviour

Original Citation

Grossoni, Ilaria and Bezin, Yann (2015) The influence of support conditions on short- and long-term track behaviour. In: The Stephenson Conference - Research for Railways, 21st - 23rd April 2015, London. (Unpublished)

This version is available at <http://eprints.hud.ac.uk/id/eprint/25615/>

The University Repository is a digital collection of the research output of the University, available on Open Access. Copyright and Moral Rights for the items on this site are retained by the individual author and/or other copyright owners. Users may access full items free of charge; copies of full text items generally can be reproduced, displayed or performed and given to third parties in any format or medium for personal research or study, educational or not-for-profit purposes without prior permission or charge, provided:

- The authors, title and full bibliographic details is credited in any copy;
- A hyperlink and/or URL is included for the original metadata page; and
- The content is not changed in any way.

For more information, including our policy and submission procedure, please contact the Repository Team at: E.mailbox@hud.ac.uk.

<http://eprints.hud.ac.uk/>

The influence of support conditions on short- and long-term track behaviour

I. Grossoni, Y. Bezin

Institute of Railway Research, University of Huddersfield, Huddersfield
United Kingdom

ABSTRACT

Railway track support conditions are known to deeply affect the dynamic performance of vehicle-track interaction, influencing the state of the track system both in the short and in the long term. Exactly how much and how is not precisely understood and the notion of track stiffness, although thought to be a key parameter of the track quality, is currently not being monitored systematically. This paper seeks to analyse the influence on the ballast behaviour of track vertical stiffness and especially its spatial non-uniformity, using available experimental data measured at different sites. Mathematical models are developed and the effectiveness of applying under sleeper pads is also investigated. Finally, an iterative procedure based on Guerin's settlement law is used to take into account the long-term behaviour of the ballast. Such models can help to understand mitigation solutions as well as predicting track quality evolution over time.

NOTATION

| Symbol | Meaning |
|-----------------------|-------------------------------------------------|
| α, β | Soil parameters for the Guerin's settlement law |
| ΔN | Incremental traffic |
| Δy | Incremental settlement |
| $\delta y_{ball,max}$ | Maximum elastic ballast deformation |
| Abbreviation | Meaning |
| FWD | Falling Weight Deflectometer |
| KS | Kolmogorov-Smirnov test |
| SD | Standard Deviation |
| USPs | Under Sleeper Pads |

1. INTRODUCTION

The performance of the railway system in terms of dynamic loading strongly depends on the track support conditions. Usually, the track stiffness is used as the main parameter to describe the support conditions and is defined as the ratio of the load applied to the rail over the vertical rail deflection [1]. Ideally that parameter is constant, but in reality this condition is very unlikely to happen, for example due to a non-uniformly compacted ballast layer, local drainage problems or presence of voids. Therefore, there is a non-uniform amplification of track forces which leads to further non-uniform track loading and, thus, to further non-uniform track degradation.

Several studies have been carried out in order to understand the influence of non-constant support stiffness on the vehicle and track dynamics, such as those in [1-4], and on the track settlement, such as in [2, 5]. Nevertheless, the influence of the actual support statistical distribution has not been fully covered.

A vehicle-track model that takes into account the vertical dynamic interaction is described in Section 2. The track irregularities and vertical support stiffness used in this study were measured at four UK sites. The influence of the statistical distribution of the non-uniform support conditions on the ballast performance is mathematically analysed in Section 3. Also the effectiveness of applying under sleeper pads is considered in Section 3. Finally, an iterative model using Guerin's settlement law is presented in Section 4 and the long-term effects of non-uniform support conditions are investigated.

2. MODELLING THE VEHICLE-TRACK SYSTEM

The vehicle-track model used in the present study is shown in Figure 1.

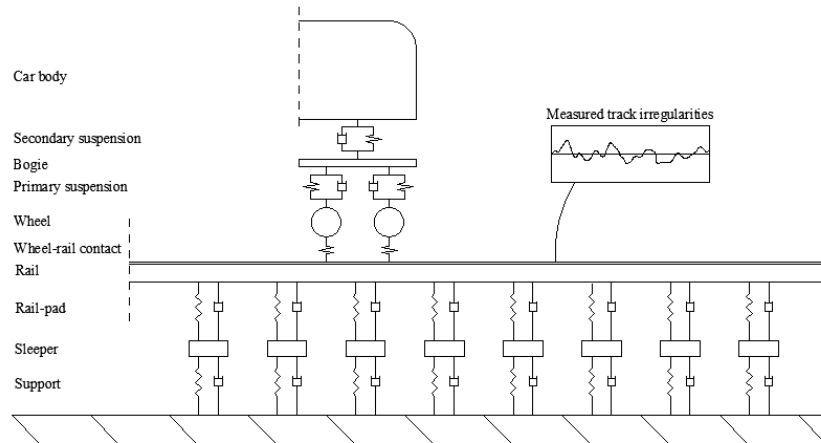

Figure 1 – Vertical vehicle-track model including measured track irregularities and measured support stiffness.

The track consists of two-layer ballasted track, including the rail-pad layer, the sleeper mass and the support layer. The rail is modelled as a Timoshenko beam. Four beam elements are considered within each sleeper-spacing in order to achieve a good resolution of results [6].

The main track parameters used in the model are:

- *Rail section:* 60E1;
- *Rail pad vertical dynamic stiffness:* 270 MN/m (medium-hard rail pad);
- *Sleeper mass:* 308 kg (typical concrete sleeper);
- *Sleeper spacing:* 0.65 m.

The vehicle is a typical freight vehicle characterised by:

- *Axle load:* 22.5 t, corresponding to circa 110 kN per wheel;
- *Suspensions:* primary and secondary suspensions, including linearized stiffness (respectively 13 and 6.2 MN/m) and linearized damping (respectively 90 and 100 kNs/m).

2.1. Experimental measurements of the support conditions

Four sets of sleeper support stiffness data have been analysed, whose main characteristics are reported in Table 1. The data was measured using Falling Weight Deflectometer (FWD) equipment.

Table 1 – Main characteristics of the measured sites.

| SITE | N. of sleepers | Support stiffness mean value [kN/mm/sleeper end] | Support stiffness SD [kN/mm/sleeper end] | KS test p -value |
|------|----------------|--------------------------------------------------|------------------------------------------|--------------------|
| 1 | 155 | 84.6 | 14.4 | 0.32 |
| 2 | 70 | 68.0 | 18.1 | 0.95 |
| 3 | 80 | 110.4 | 16.2 | 0.90 |
| 4 | 81 | 71.0 | 8.6 | 0.76 |

The curve fitting is shown in Figure 2, assuming a normal distribution of the support stiffness. This hypothesis has been validated performing the Kolmogorov-Smirnov (KS) test and checking that the p -value of each set of data (Table 1) is not less than the 10% significance level.

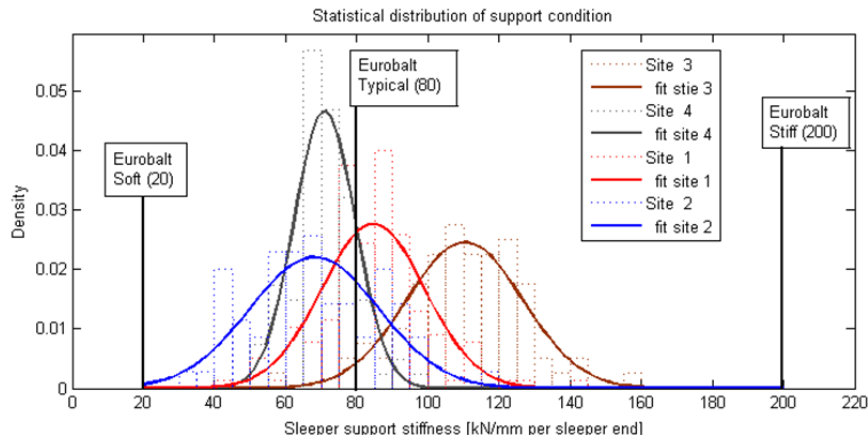

Figure 2 – Curve fitting for the four sites considered.

In Figure 2 the values reported in the EUROBALT project for 'soft', 'typical' and 'stiff' are also shown for comparison. This highlights the fact that the mean values for all sites are representative of typical values, i.e. situated around 80 kN/mm. Some of the extreme low values are just above 'soft' while the extreme high values are close to 160 kN/mm.

3. SHORT-TERM BEHAVIOUR

In this section, the influence of the support conditions on the track short-term behaviour is assessed. In particular, the response in terms of ballast forces without (Section 3.1) and with (Section 3.2) USPs are analysed.

The speeds considered in the present study are 80, 120 and 140 km/h, which are speeds considered by the authors as part of the European project SUSTRAIL investigating the possibility to raise maximum speed for freight wagon from 120 to 140 km/h on the basis of track and vehicle running gears innovation.

It is worth underlining that the ballast forces quoted hereafter are for one rail as the model is that of a half track, assuming symmetrical vehicle-track configuration and loading.

3.1. Without under sleeper pads

Figure 3(a) shows, for the three speeds considered in this study, the maximum ballast forces at each site. The relative differences between these values and the mean value of the four sites are depicted in Figure 3(b).

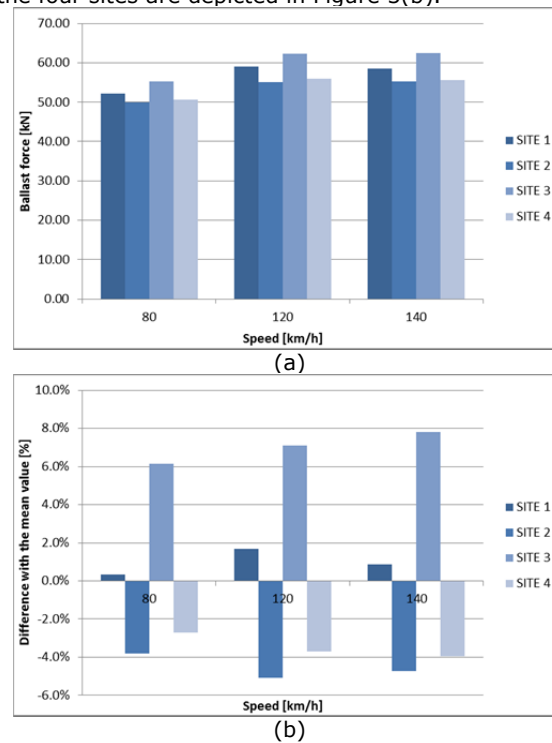

Figure 3 - (a) Maximum ballast forces at each site for speeds 80, 120 and 140 km/h; (b) Relative differences between these values and the mean value of the four sites.

Table 2 - Mean values of ballast force as a function of speed.

| Speed [km/h] | Ballast force mean value [kN] |
|--------------|-------------------------------|
| 80 | 52 |
| 120 | 58 |
| 140 | 58 |

From Figure 3(a) and Table 2 it can be observed that there is an increase in ballast force from speed 80 to 120km/h, while the forces seem to level out between 120 and 140km/h. Force fluctuations (difference with mean values across the four sites) are quoted with the higher values observed at site 3 (highest support stiffness mean value) and the lowest values observed at site 2 (lowest support stiffness mean value).

The standard deviation of the ballast force as a function of the mean value of the support stiffness is shown in Figure 4(a), and in Figure 4(b) as a function of the standard deviation of the support stiffness.

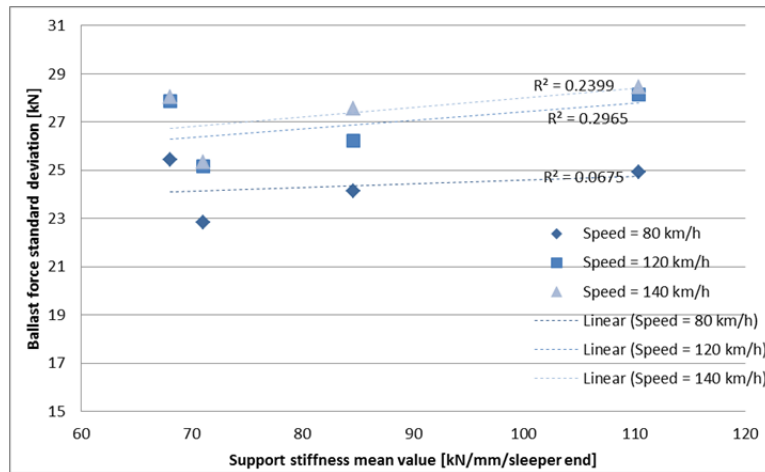

(a)

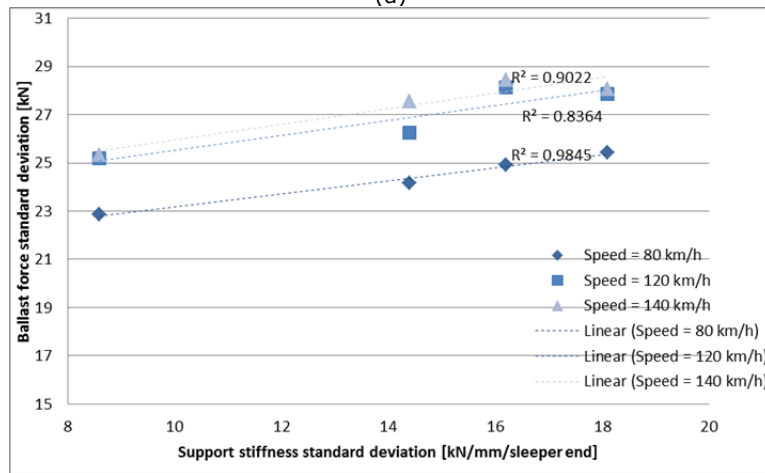

(b)

Figure 4 - Ballast force SD as function of (a) support stiffness mean value and (b) support stiffness SD.

Regarding the plots in Figure 4 and analysing the R^2 values, it is possible to notice that the support stiffness SD influences the variation of the ballast forces, more than the support stiffness mean value. This finding is in line with the previous studies on the vertical dynamics, according to which the main driver of the dynamic amplification and differential settlement is the distribution of support conditions rather than the mean value [4, 7]. In fact, assuming a linear trend the R^2 values are very high in all the speed cases when analysing the influence of support SD and quite low when analysing the influence of support mean values. Moreover, increasing the speed leads to an average increase of the ballast force SD (Figure 4), as expected.

A detailed analysis of the results, which is not presented in the present article, allows verifying that the variation of ballast force attributed to support stiffness can lead to an increase of up to 30% (25% on average) with respect to the case where stiffness is considered homogeneous. At the same time certain sleepers can see a reduction of force by up to 26% (-23% on average). Therefore, it can be concluded

that a variability in the support conditions leads to a strong variability in the short-term behaviour of ballast forces and, thus, in the long-term behaviour.

3.2. With under sleeper pads

In Figure 5 the maximum ballast forces versus USP stiffness for different speed are presented per each site.

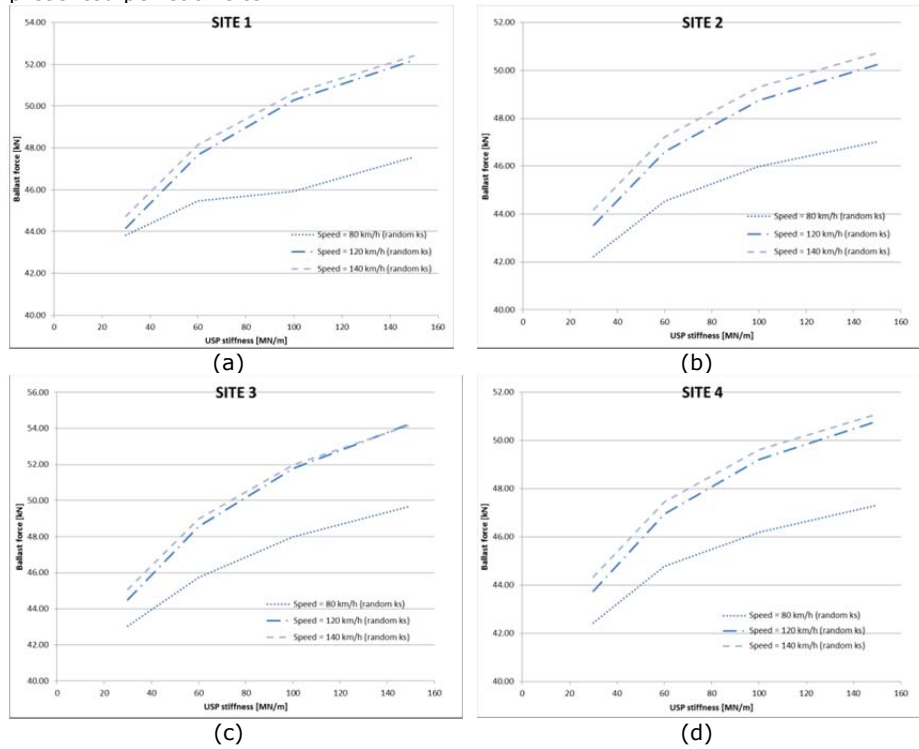
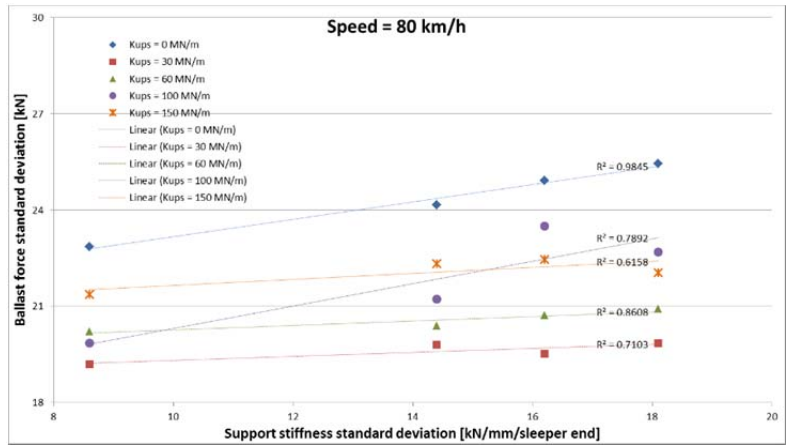

Figure 5 – Maximum ballast forces versus USP stiffness for different speeds at (a) site 1, (b) site 2, (c) site 3 and (d) site 4.

From Figure 5 it can be deduced that there is a parabolic increase of ballast force with increasing USP stiffness in case of all the speed and sites considered. For example, in case of site 1 there is an average decrease of 14% with respect the situation where no USP is present for speed equal to 80 km/h and an average decrease of 19% for speed equal to 140 km/h.

From a more detailed analysis of all the results not presented in this article, it is possible to notice that the greatest decrements in maximum forces, up to 30-40%, are in case of highest speed values (120-140 km/h), the highest mean support stiffness (site 1 and site 3) and the lowest USP stiffness (30-60 MN/m). Instead, when the mean support stiffness is already low (site 2 and site 4), the advantage of using USPs is greatly reduced, becoming almost negligible for the highest USP stiffness values.

Figure 6 shows the ballast force SD as function of the support stiffness SD for different USP stiffness values, as well as the related trend lines.



(a)

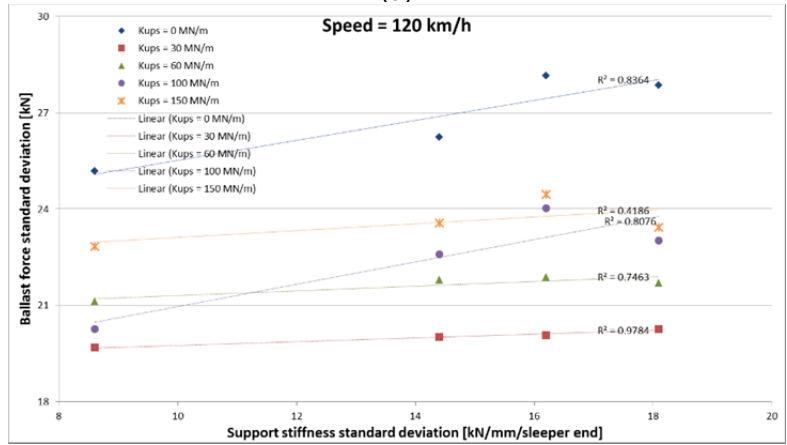

(b)

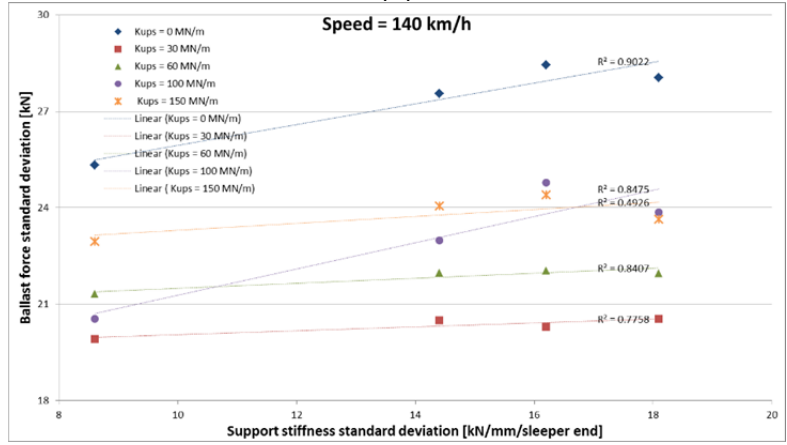

(c)

Figure 6 - Ballast force SD as function of support stiffness SD for different USP stiffness values for speed (a) 80 km/h; (b) 120 km/h; (c) 140 km/h.

Figure 6 confirms that the presence of USPs also helps to reduce the dispersion in the ballast forces in all speed cases analysed. This reduction follows the same trend of reduction in the ballast forces, i.e. the greatest reductions are in case of highest speed values, the highest mean support stiffness and the lowest USP stiffness. Moreover, it is possible to notice that the R^2 value is very high in case of low speed (80 km/h) and in case of low USP stiffness (30-60 MN/m) because of the lower dynamic dispersion.

To conclude, all the graphs show how the presence of the USPs can effectively help the reduction of force peak value and dispersion in the ballast forces and how this reduction depends on both the actual support stiffness distribution and the chosen USP stiffness. This reduction in force would in practice lead to a further reduction of pressure in the ballast and therefore a significant reduction in differential settlement as shown in Section 4.

4. LONG-TERM BEHAVIOUR

The track long-term behaviour in terms of settlement has been calculated following an iterative procedure (Figure 7): after the initialization with the vehicle, track and vertical rail profile data, the dynamic response of the coupled system is calculated in terms of contact forces and displacements. Later, the track settlement law is applied and the incremental settlement Δy due to the incremental traffic ΔN is calculated. Finally, a check in terms of maximum settlement and maximum traffic is performed to decide on the continuation of the iterative process.

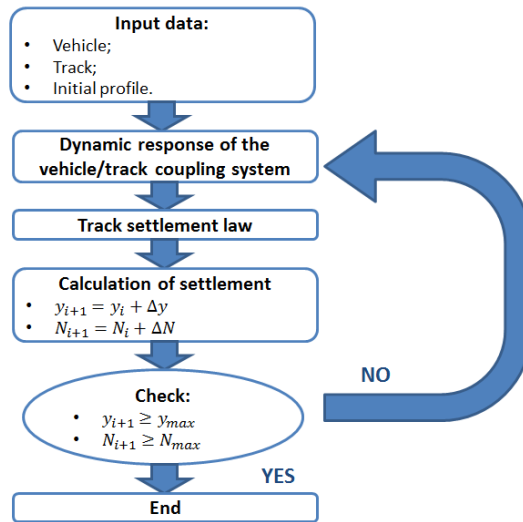

Figure 7 – Iterative process to calculate the track long-term behaviour.

In the present study, the Guerin's law [8] adopted and the incremental settlement is calculated as:

$$\Delta y = \Delta N \cdot \alpha \cdot \delta y_{ball,max}^\beta$$

Where $\delta y_{ball,max}$ is the maximum elastic ballast deformation and α and β two coefficients.

An example of the evolution of vertical track geometry is shown in Figure 8.

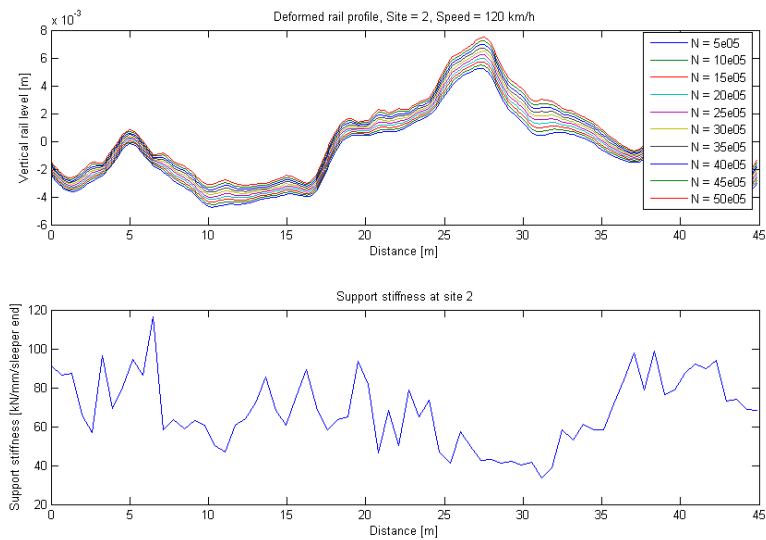

Figure 8 - Evolution of the vertical track geometry for various cumulative traffic (top), and support stiffness along distance at site 2 (bottom).

From that figure, it is possible to deduce how the two properties are strictly linked. In fact, the locations characterized by the highest support stiffness values (e.g. at circa 6.5 m the total settlement is 0.085 mm) experience lower long-term deformation than the locations characterized by the lowest support stiffness values (e.g. at circa 31.5 m the total settlement is 0.29 mm). This result is in line with what is expected.

The track data obtained in the simulations have been treated with a band-pass filter between 3 m and 25 m, as suggested in [9] for speeds lower than 200 km/h. Usually, track quality is estimated as the standard deviation of top level and alignment over 200-meter long sections (or approximately "an eight of a mile"). In this study, it is not possible to apply that rule because of the limited available support stiffness data (Table 1). In further work this aspect will be taken into account developing a methodology in order to extrapolate from the real data and produce a new set of support conditions with the same statistical characteristics.

The speed plays an important role: increasing the speed leads to an increase of the settlement, although increasing from 120 to 140 km/h shows very little difference. An example for site 3 is shown in Figure 9.

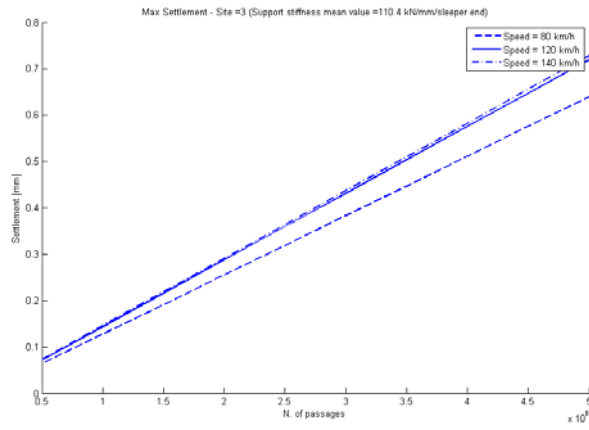
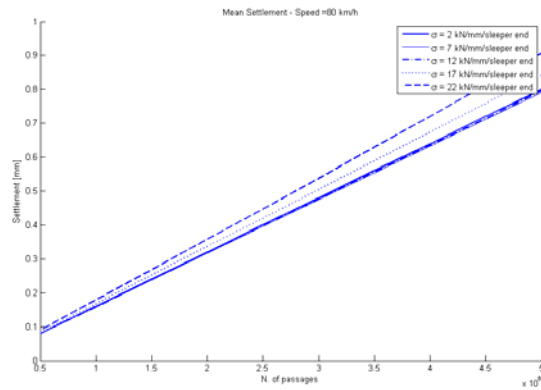
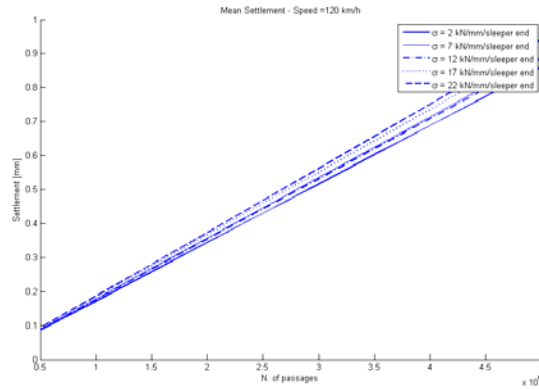

Figure 9 – Mean settlement in site 3 versus number of passages for different speeds.

In order to study the influence of the stiffness SD, it is necessary to isolate the effect of the track stiffness mean value fixing a common mean value (e.g. 80 kN/mm/sleeper end) and artificially varying the SD (e.g. 2/7/12/17/22 kN/mm). In Figure 10 the mean settlement values versus number of passages varying the support stiffness SD is presented.



(a)



(b)

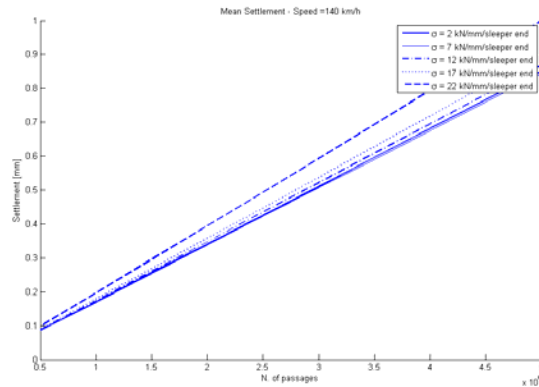

(c)

Figure 10 - Mean settlement versus number of vehicle passage for different support stiffness SD and for speed (a) 80 km/h; (b) 120 km/h; (c) 140 km/h.

As expected, Figure 10 shows that as the variation in support stiffness increases, the mean settlement values increases accordingly. This is the case for all speeds.

To conclude, the track long-term behaviour is greatly influenced by both the stiffness mean value and standard deviation, as well as by the vehicle speed

5. CONCLUSIONS

The primary objective of this study was to investigate the influence of the support condition, most specifically the global stiffness, on both track short- and long-term behaviour. A vertical model of vehicle-track interaction, including measured stiffness data from four UK sites, has been used for this purpose. For these sets of data the hypothesis that vertical support stiffness follows a normal distribution is not rejected through the KS goodness-of-fit statistical tests.

Regarding the short-term behaviour, it has been demonstrated how the variability of the support stiffness, described through the standard deviation, leads to high variation in imposed ballast forces. The numerical model used also shows that the presence of USPs can also effectively help reducing both peak forces and the

variation in ballast forces. The actual reduction depends on both the support stiffness distribution and the chosen USP stiffness.

Regarding the long-term behaviour, the results show that track settlement is strongly depending on the support condition. Not only the support stiffness mean values affects the track settlement but also the standard deviation.

Finally, it is worth underlining that this paper describes a methodology which can mathematically evaluate the dynamic reaction of vehicle and track including varying support stiffness. This therefore represents a robust platform for further work to understand long-term track settlement and evaluate remediation actions (e.g. here with USPs). The work will be further developed to include a statistical approach which will allow realistic extrapolation of the site specific measured stiffness data, to produce larger sets of data with identical characteristics (mean value and spatial variability).

AKNOWLEDGMENTS

The present work has been supported by the European Commission within the FP7 Sustrail project [grant n. 265740].

The authors would also like to thank Dr Antonio Andrade (University of Huddersfield) for his help in the statistical analysis.

REFERENCES

1. Dahlberg, T., *Railway track stiffness variations – consequences and countermeasures*. International Journal of Civil Engineering, 2010. **8**(1): p. 12.
2. Frohling, R.D., *Deterioration of railway track due to dynamic vehicle loading and spacially varying track stiffness* in *Faculty of Engineering1997*, University of Pretoria: Pretoria.
3. Li, M.X.D. and E.G. Berggren, *A study of the effect of global track stiffness and its variations on track performance: Simulation and measurements*. Proceedings of the Institution of Mechanical Engineers, Part F: Journal of Rail and Rapid Transit, 2010. **224**: p. 8.
4. Lopez Pita, A., P.F. Teixeira, and F. Robuste, *High speed and track deterioration: The role of vertical stiffness of the track*. Proceedings of the Institution of Mechanical Engineers, Part F: Journal of Rail and Rapid Transit, 2004. **218**: p. 10.
5. Frohling, R.D., H. Scheffel, and W. Ebersohn, *The vertical dynamic response of a rail vehicle caused by track stiffness variations along the track*. Vehicle System Dynamics, 1996. **25 Suppl.1**: p. 13.
6. Grossoni, I., et al., *Dynamics of a vehicle–track coupling system at a rail joint* Proceedings of the Institution of Mechanical Engineers, Part F: Journal of Rail and Rapid Transit, To be published.
7. Birmann, F. and J. Eisenmann, *Serial measurements on rails to determine wheel lateral forces*. Eisenbahntechnische Rundschau, 1966. **15**(5): p. 10.
8. Guerin, N., *Approche experimentale et numerique du comportement du ballast des voies ferrees*, in *Structures et materiaux1996*, Ecole nationale des ponts et chausses: Paris.
9. European Committee for Standardization, *Railway applications. Testing for the acceptance of running characteristics of railway vehicles. Testing of running behavior and stationary tests*, 2005.