



University of HUDDERSFIELD

University of Huddersfield Repository

Zuriekat, Majdy Issa Khalil

Performance measurement systems : an examination of the influence of the contextual factors and their impact on performance with a specific emphasis on the balanced scorecard approach

Original Citation

Zuriekat, Majdy Issa Khalil (2005) Performance measurement systems : an examination of the influence of the contextual factors and their impact on performance with a specific emphasis on the balanced scorecard approach. Doctoral thesis, University of Huddersfield.

This version is available at <http://eprints.hud.ac.uk/id/eprint/4613/>

The University Repository is a digital collection of the research output of the University, available on Open Access. Copyright and Moral Rights for the items on this site are retained by the individual author and/or other copyright owners. Users may access full items free of charge; copies of full text items generally can be reproduced, displayed or performed and given to third parties in any format or medium for personal research or study, educational or not-for-profit purposes without prior permission or charge, provided:

- The authors, title and full bibliographic details is credited in any copy;
- A hyperlink and/or URL is included for the original metadata page; and
- The content is not changed in any way.

For more information, including our policy and submission procedure, please contact the Repository Team at: E.mailbox@hud.ac.uk.

<http://eprints.hud.ac.uk/>

**PERFORMANCE MEASUREMENT SYSTEMS: AN EXAMINATION
OF THE INFLUENCE OF THE CONTEXTUAL FACTORS AND THEIR
IMPACT ON PERFORMANCE WITH A SPECIFIC EMPHASIS ON
THE BALANCED SCORECARD APPROACH**

MAJDY ISSA KHALIL ZURIEKAT

Ph. D.

APRIL 2005

**Performance Measurement Systems: An Examination of the Influence of
the Contextual Factors and their Impact on Performance with a Specific
Emphasis on the Balanced Scorecard Approach.**

Majdy Issa Khalil Zuriekat

**A Thesis Submitted to the University of Huddersfield in Partial Fulfilment of the
Requirements for the Degree of Doctor of Philosophy**

**The University of Huddersfield
Huddersfield University Business School**

April 2005

Abstract

In an attempt to understand the performance measurement systems, this study utilises the contingency theory theoretical framework to examine the contingent relationships between several contextual factors and the usage of financial and non-financial performance measures for performance measurements and evaluation purposes. The contextual factors consist of business strategy, organisational structure, perceived environmental uncertainty, intensity of competition, organisation size, total quality management and just in time manufacturing approaches. This study also investigates the implications of fit (internal consistency) between the above contextual factors and the extent of performance measurement diversity usage on organisational effectiveness (i.e. organisational performance and level of satisfaction). Nine performance measurement categories are investigated including: financial, customer, operational, innovation, employee, supplier, environment, quality and community categories. During the 1990s and until recently, considerable publicity and interest has been given to the balanced scorecard approach (BSC). This study also gathers empirical data to investigate various issues relating to BSC approach. The major aims of the study are to examine how the manufacturing companies are dealing with this approach and to determine the extent to which the above contextual factors influence the extent of balanced scorecard usage.

The findings are based on a questionnaire mailed to a target sample of 900 UK manufacturing companies with an annual sales turnover in excess of £50 million. A total of 163 usable responses were received representing a response rate of 19.7%. For the purpose of data analysis, the study utilises descriptive statistics and multivariate statistics (i.e. structural equation modelling using EQS 5.7 and multiple regression).

The results of the descriptive analysis show that financial, customer, operational and quality performance categories are extensively used for performance measurements and evaluation purposes. Other non-financial performance categories (i.e. innovation, supplier, employee, and environment) are also used but to a lesser extent. Despite the popularity of the balanced scorecard (BSC) approach, only a minority of companies (30%) reported using it in their performance measurement systems. The findings also emphasise the inconsistency between companies following the BSC approach, particularly the number and types of perspectives used. The results of structural equation modelling suggest a strong support for the cost strategy, formalisation, regulatory aspects of perceived environmental uncertainty, size, aspects relating to the intensity of competition and the extent of the use of both total quality management and just in time manufacturing approaches have a significant influence on the extent of performance measurement diversity usage (i.e. financial and non-financial performance measures). The results also indicate that the different approaches to fit utilised in this study (i.e. bivariate and systems approaches), based on structural equation modelling, result in insightful findings relating to the contingent relationships between the anticipated contextual factors, the extent of performance measurement diversity usage and organisational effectiveness. The results using multiple regression indicate that formalisation, raw material aspects of perceived environmental uncertainty, size and the extent of the use of total quality management significantly influence the extent of balanced scorecard usage.

A distinguishing feature of this study is that it extends previous BSC studies in determining the extent of balanced scorecard usage. The results suggest that using financial and non-financial performance measures does not necessarily imply that the companies are really balanced scorecard users. This finding therefore raises implications for future balanced scorecard researchers, and by drawing off contingency theory literature, it overcomes some of the deficiencies of previous research relating to balanced scorecard approach. Finally, this study contributes to the literature by utilising the structural equation modelling method, which has several advantages over other multivariate data analysis.

Acknowledgments

Writing this piece of work may have never been completed without the help of many people. First, I am greatly indebted to my Director of Studies, Professor Colin Drury for his kindness and wisdom, as well as his keenness to guide and council me and review my work throughout the period of this study. I am also indebted for his encouragement and patience. In addition, he has helped me to shape appropriate ideas into research, and this has had a great influence on me as a researcher. Also, this study could not have been completed without his precious supervision, advice and comments. I am therefore very grateful, honoured and proud to have had Professor Colin as the director of my study. I would also like to acknowledge Dr. Messaoud Mehafdi, my second supervisor for his useful comments on my research proposal, questionnaire and on the final draft of this thesis.

I would like to acknowledge all the kindness and support that I have received from many members of the academic and administrative staff at Huddersfield University Business School. In particular, Ms. Wilma Teviotdale, Head of Accountancy Department for her kindness and support. I would also like to thank Linda Hall, Departmental Secretary, Sandra Cromack, Secretary, Lindsay Coales, Administrative Assistant, and Mark Curry for their kind assistance. In addition, I would like to extend my thanks to Randall Russell from Balanced Scorecard Collaborative, Professor Eric Olson from University of Colorado, Dr. Zahirul Hoque from Griffith University, Dr. Steen Nielsen from Aarhus School of Business, Professor Thomas Guenther from Dresden University of Technology and Professor Thomas Pfeiffer from University of Vienna who were willing to provide me with useful comments and invaluable papers. Many thanks are also due to those respondents from UK manufacturing companies who took the time to respond to the questionnaire survey. I am also delighted to acknowledge all the help and support that I have received from my colleagues: Dr. Mohammed AlDahiyat and Dr. Firas Alkhalidi.

My special gratitude goes to my best friends Abdulkareem Awwad, Fahed Khatib, Maher Hawamleh, Faisal Jaafreh and Huda Alhussari.

I would like to express my thanks and appreciation to the magnificent couple, Shirley and Brian Bowden, for their kindness, care, encouragement and love during the time that I have spent with them as part of their family.

Finally, I am thankful and indebted to my parents for their continuous support and love and for their prayers for me to succeed in my life. I am also indebted to my brother Tamer for his support and encouragement. Also, I would like to extend my deepest appreciation to my best friend Ehab and his wife for their support. Last but not least, I would like to express my sincere gratitude to my special young lady '*Marian Jankotchian*' for her sacrifices and support.

Table of contents

List of tables.....	x
List of figures.....	xiii

Chapter 1 Introduction

1.1 Introduction.....	1-2
1.2 Background to the study.....	1-2
1.3 Research aim and objectives.....	1-5
1.4 Alternative management accounting research.....	1-5
1.5 Research contribution.....	1-11
1.6 Structure of the thesis.....	1-12

Chapter 2 Performance measurement systems

2.1 Introduction.....	2-2
2.2 Management control.....	2-3
2.3 Performance measurement systems: Definition and design.....	2-6
2.4 The development of performance measurements.....	2-11
2.5 Financial performance measurements.....	2-13
2.6 Limitations of financial performance measurements.....	2-14
2.7 The changing basis of performance measurements.....	2-16
2.8 Non-financial performance measurements.....	2-18
2.8.1 Non-financial performance measurements as leading indicators.....	2-22
2.8.2 Non-financial performance measurements and manufacturing practices....	2-24
2.8.3 Non-financial performance measurements and compensation plans.....	2-25
2.8.4 Notions and boundaries of non-financial performance measurements.....	2-26
2.9 Integrated performance measurement frameworks.....	2-28
2.9.1 The performance measurement matrix.....	2-29
2.9.2 The performance measurement questionnaire.....	2-30
2.9.3 The performance pyramid model.....	2-31
2.9.4 The performance measurement system for the service industry.....	2-32
2.9.5 The EFQM business excellence model.....	2-34
2.9.6 The performance prism.....	2-34
2.9.7 The tableaux de bord.....	2-35

2.9.8	The balanced scorecard.....	2-36
2.10	Strategic performance measurement systems.....	2-36
2.11	New financial performance measurements.....	2-38
2.11.1	Economic value added.....	2-38
2.11.2	Cash flow return on investment.....	2-39
2.12	The choice of strategic performance measurement system.....	2-40
2.13	Summary.....	2-41

Chapter 3 Balanced scorecard approach

3.1	Introduction.....	3-2
3.2	The emergence of the balanced scorecard approach.....	3-3
3.3	Strategic management system assumption.....	3-7
3.4	The cause-and-effect assumption.....	3-10
3.5	Balanced scorecard relevant literature review.....	3-11
3.6	Evaluating the balanced scorecard approach.....	3-24
3.6.1	The popularity of the balanced scorecard.....	3-24
3.6.2	The balanced scorecard as a strategic management tool.....	3-27
3.6.3	The balanced scorecard as a cause-and-effect model.....	3-28
3.6.4	The number of balanced scorecard perspectives and measures.....	3-29
3.6.5	Balanced scorecard models.....	3-31
3.6.6	Balanced scorecard and compensation plans.....	3-32
3.7	Benefits and limitations of the balanced scorecard approach.....	3-33
3.8	An overview of the balanced scorecard approach.....	3-35
3.9	Summary.....	3-36

Chapter 4 The contingency theory of management accounting

4.1	Introduction.....	4-2
4.2	The contingency theory of organisation structure.....	4-3
4.2.1	The effect of environment.....	4-4
4.2.2	The effect of technology.....	4-5
4.2.3	The effect of size.....	4-5
4.3	Organisational effectiveness and the concept of fit.....	4-6
4.4	The contingency theory of management accounting and control systems.....	4-8
4.5	Limitations of contingency theory studies.....	4-13

4.6	A discussion of the contingency variables adopted in this study.....	4-15
4.7	An overview of the contingent variables, performance measurements and the balanced scorecard.....	4-17
4.7.1	Business strategy.....	4-18
4.7.2	Organisational structure.....	4-23
4.7.3	Perceived environmental uncertainty.....	4-26
4.7.4	Intensity of competition.....	4-28
4.7.5	Organisation size.....	4-29
4.7.6	Manufacturing practices.....	4-30
4.7.6.1	Total quality management.....	4-30
4.7.6.2	Just in time manufacturing approaches.....	4-32
4.8	Summary.....	4-33

Chapter 5
Research theoretical model and hypotheses

5.1	Introduction.....	5-3
5.2	Building the research theoretical model.....	5-3
5.2.1	Justification for building the first research theoretical model.....	5-4
5.2.2	Justification for building the second research theoretical model.....	5-7
5.3	Research aim and objectives.....	5-11
5.4	Operational definition of the research variables.....	5-12
5.4.1	Operationalising the contingent variables.....	5-13
5.4.1.1	Business strategy.....	5-13
5.4.1.2	Organisational structure.....	5-14
5.4.1.3	Perceived environmental uncertainty.....	5-14
5.4.1.4	Intensity of competition.....	5-15
5.4.1.5	Organisation size.....	5-16
5.4.1.6	Total quality management.....	5-16
5.4.1.7	Just in time manufacturing approaches.....	5-16
5.4.2	Operationalising the extent of performance measurement diversity usage (PMD).....	5-17
5.4.3	Operationalising the extent of balanced scorecard usage (BSCUSE).....	5-19
5.4.4	Operationalising organisational effectiveness.....	5-21
5.5	Research variables and hypotheses formulation.....	5-22
5.5.1	Hypotheses relating to factors influencing the extent of performance measurement diversity usage (PMD).....	5-22

5.5.1.1	Business strategy and the extent of PMD usage.....	5-23
5.5.1.2	Organisational structure and the extent of PMD usage.....	5-24
5.5.1.3	Perceived environmental uncertainty and the extent of PMD usage.....	5-24
5.5.1.4	Intensity of competition and the extent of PMD usage.....	5-25
5.5.1.5	Organisation size and the extent of PMD usage.....	5-25
5.5.1.6	Total quality management and the extent of PMD usage.....	5-26
5.5.1.7	Just in time manufacturing approaches and the extent of PMD usage.....	5-26
5.5.2	Hypotheses relating to the effectiveness of PMD usage.....	5-27
5.5.3	Hypotheses relating to factors influencing the extent of balanced scorecard usage.....	5-28
5.5.3.1	Business strategy and the extent of balanced scorecard usage....	5-28
5.5.3.2	Organisational structure and the extent of balanced scorecard usage.....	5-29
5.5.3.3	Perceived environmental uncertainty and the extent of balanced scorecard usage.....	5-30
5.5.3.4	Intensity of competition and the extent of balanced scorecard usage.....	5-30
5.5.3.5	Organisation size and the extent of balanced scorecard usage.....	5-30
5.5.3.6	Total quality management and the extent of balanced scorecard usage.....	5-31
5.5.3.7	Just in time manufacturing approaches and the extent of balanced scorecard usage.....	5-31
5.6	Summary.....	5-32

Chapter 6
Research methodology

6.1	Introduction.....	6-2
6.2	Research philosophy.....	6-2
6.3	Research design.....	6-6
6.4	Research population.....	6-8
6.5	Research sample and sampling frame.....	6-9
6.6	Data collection methods.....	6-11
6.6.1	Interviews.....	6-12

6.6.2	Questionnaire types and formats.....	6-12
6.6.2.1	Personally administered questionnaires.....	6-12
6.6.2.2	On-line questionnaires.....	6-13
6.6.2.3	Mail questionnaires.....	6-13
6.7	Questionnaire construction and pre-testing.....	6-14
6.7.1	Question types and format.....	6-15
6.7.2	Questionnaire layout and flow.....	6-17
6.7.3	Questionnaire pre-testing and pilot work.....	6-18
6.8	Features of the covering letter.....	6-20
6.9	Content of the final draft of the questionnaire.....	6-21
6.10	The individual respondents.....	6-24
6.11	Administering the questionnaire and response profile.....	6-24
6.11.1	Characteristics of responding firms.....	6-25
6.11.2	Characteristics of respondents.....	6-26
6.12	Check for non-response bias.....	6-27
6.13	Validity and reliability.....	6-30
6.13.1	Validity.....	6-30
6.13.2	Reliability.....	6-32
6.14	Statistical methods used in data analysis.....	6-32
6.14.1	Descriptive statistics.....	6-33
6.14.2	Exploratory factor analysis (EFA).....	6-34
6.14.3	Structural equation modelling (SEM).....	6-34
6.14.4	Correlation and multiple regression.....	6-37
6.15	Summary.....	6-38

Chapter 7
A description of the research findings

7.1	Introduction.....	7-2
7.2	The importance of performance categories to long-term organisational success and their use in performance measurements and evaluation.....	7-2
7.2.1	Importance to long-term organisational success.....	7-2
7.2.2	Setting strategic goals.....	7-4
7.2.3	Managerial performance evaluation.....	7-6
7.2.4	Financial reward system.....	7-7
7.2.5	Measurement quality.....	7-8
7.2.6	Problem identification.....	7-9

7.3	Performance measurement gap.....	7-10
7.4	Performance measurements used by business units.....	7-14
	7.4.1 Linking performance measures to strategies.....	7-16
	7.4.2 The link between performance measures.....	7-17
7.5	State of balanced scorecard implementation.....	7-19
	7.5.1 Type of balanced scorecard perspectives.....	7-20
	7.5.2 Number of strategic objectives and measures used in the balanced scorecard.....	7-23
	7.5.3 Balanced scorecard components.....	7-25
	7.5.4 Results of balanced scorecard implementation.....	7-26
	7.5.5 Level of balanced scorecard implementation.....	7-27
7.6	Mean differences between balanced scorecard users and non-users.....	7-28
7.7	Respondents' satisfaction with performance measurement systems.....	7-31
7.8	Summary.....	7-32

Chapter 8
Measurement model analysis

8.1	Introduction.....	8-2
8.2	Measurement analysis of research variables.....	8-2
	8.2.1 Business strategy.....	8-3
	8.2.2 Organisational structure.....	8-5
	8.2.3 Perceived environmental uncertainty.....	8-6
	8.2.4 Intensity of competition.....	8-8
	8.2.5 Organisation size.....	8-9
	8.2.6 Total quality management.....	8-10
	8.2.7 Just in time manufacturing approaches.....	8-11
	8.2.8 The extent of performance measurement diversity usage (PMD).....	8-12
	8.2.9 The extent of balanced scorecard usage (BSCUSE).....	8-14
	8.2.10 Organisational effectiveness.....	8-17
8.3	Descriptive statistics for research variables.....	8-19
8.4	Statistical methods used for testing research hypotheses.....	8-21
	8.4.1 Structural equation modelling assumptions.....	8-21
	8.4.2 Structural equation modelling computer programs.....	8-22
	8.4.3 Dealing with outliers and missing data.....	8-22
	8.4.4 The structural model goodness-of-fit evaluation.....	8-23
	8.4.5 Statistical significance of parameters estimates.....	8-24

8.4.6	Sample size and model complexity.....	8-25
8.4.7	The variables used in testing research hypotheses.....	8-27
8.5	Summary.....	8-28

Chapter 9
Testing the research hypotheses

9.1	Introduction.....	9-2
9.2	Testing the hypotheses relating to factors influencing the extent of performance measurement diversity usage (PMD).....	9-2
9.3	Testing the hypotheses relating to the effectiveness of performance measurement diversity usage.....	9-17
9.4	Testing the hypotheses relating to factors influencing the extent of balanced scorecard usage (BSCUSE).....	9-25
9.5	Summary.....	9-36

Chapter 10
Conclusions and implications

10.1	Introduction.....	10-2
10.2	Summary of the research findings.....	10-4
	10.2.1 The results of the descriptive statistics.....	10-4
	10.2.2 The results of hypotheses testing relating to factors influencing the extent of performance measurement diversity usage.....	10-10
	10.2.3 The results of hypotheses testing relating to the effectiveness of performance measurement diversity usage.....	10-12
	10.2.4 The results of hypotheses testing relating to factors influencing the extent of balanced scorecard usage.....	10-12
10.3	Implications of research findings to knowledge.....	10-14
	10.3.1 Implications for academics.....	10-14
	10.3.2 Implications for managers.....	10-17
10.4	Limitations and further research agenda.....	10-18
10.5	Conclusion.....	10-23
	References.....	R-1
	Appendices.....	
	Appendix A: Research questionnaire.....	A-1
	Appendix B: Questionnaire covering letter.....	B-1
	Appendix C: Questionnaire first reminder letter.....	C-1
	Appendix D: Questionnaire second reminder letter.....	D-1

List of Tables

Table 2.1	A comparison between traditional and non-traditional performance measures.....	2-19
Table 2.2	Quality, uses and importance of financial and non-financial performance measures.....	2-20
Table 2.3	Section of part two of the performance measurement questionnaire.....	2-31
Table 2.4	Performance measurement system for service industries.....	2-33
Table 3.1	Designing a balanced scorecard.....	3-6
Table 3.2	Differences and similarities between the balanced scorecard and the tableaux de bord.....	3-16
Table 3.3	Comparison of the three control techniques.....	3-16
Table 3.4	Comparison between the balanced scorecard and the EFQM.....	3-17
Table 3.5	Suggested number of measures in each balanced scorecard perspective.....	3-31
Table 4.1	Contingent variables grouped by major categories.....	4-11
Table 4.2	Generic strategies and management accounting.....	4-21
Table 4.3	Mechanistic and organic organisation forms.....	4-23
Table 6.1	Implications of positivism & social constructionism.....	6-3
Table 6.2	Alternative terms for the research paradigms.....	6-3
Table 6.3	Strengths and weaknesses of research schools.....	6-5
Table 6.4	Survey response profile.....	6-25
Table 6.5	Characteristics of responding firms.....	6-26
Table 6.6	Characteristics of respondents.....	6-27
Table 6.7	Chi-square test comparing industry type between early and late respondents.....	6-29
Table 6.8	Mann-Whitney test comparing company size between early and late respondents.....	6-29
Table 6.9	Chi-square test comparing industry type between respondents and non-respondents.....	6-29
Table 6.10	Mann-Whitney test comparing company size between respondents and non-respondents.....	6-30
Table 6.11	Differences and similarities between structural equation modelling and standard approaches.....	6-35
Table 6.12	Recommended values of goodness-of-fit measures.....	6-37
Table 7.1	Descending means and the relative weight placed on performance categories as drivers of long-term organisational success.....	7-3

Table 7.2	Descending means and the relative weight placed on setting strategic goals to performance categories.....	7-5
Table 7.3	Descending means and the relative weight placed on performance categories to evaluate managerial performance.....	7-6
Table 7.4	Descending means and the relative weight placed on linking performance categories to financial reward system.....	7-7
Table 7.5	Descending means in relation to measurement quality within each performance category.....	7-8
Table 7.6	Descending means and the relative weight placed on performance categories to identify problems and improvement opportunities and developing action plans.....	7-9
Table 7.7	Mean survey responses on the importance of performance categories to long-term organisational success and their use in performance measurements and evaluation.....	7-11
Table 7.8	Average usage of performance measurements.....	7-14
Table 7.9	Distribution of the linkages between performance measures and strategies.....	7-16
Table 7.10	Distribution of the linkages between non-financial performance measures and future financial performance outcomes.....	7-18
Table 7.11	State of balanced scorecard implementation stages.....	7-19
Table 7.12	Type of perspectives used in the balanced scorecard.....	7-21
Table 7.13	Number of perspectives used in the balanced scorecard.....	7-22
Table 7.14	Components of the perspectives used by the balanced scorecard companies.....	7-22
Table 7.15	Analysis of strategic objectives used for each perspective.....	7-23
Table 7.16	Analysis of performance measures used for each perspective.....	7-24
Table 7.17	Total number of strategic objectives and measures used in the balanced scorecards.....	7-24
Table 7.18	Components of the balanced scorecards.....	7-25
Table 7.19	Results of balanced scorecard implementation.....	7-26
Table 7.20	Level of balanced scorecard implementation.....	7-27
Table 7.21	Significant mean differences in performance categories and measurement characteristics between balanced scorecard users and non-users.....	7-29
Table 7.22	Significant mean differences in performance measurement characteristics between balanced scorecard users and non-users.....	7-31

Table 7.23	Respondents' satisfaction with performance measurement systems.....	7-31
Table 7.24	Characteristics of balanced scorecard users in terms of industry type...	7-32
Table 8.1	Exploratory factor analysis for business strategy.....	8-4
Table 8.2	Exploratory factor analysis for organisational structure.....	8-5
Table 8.3	Exploratory factor analysis for perceived environmental uncertainty (PEU).....	8-7
Table 8.4	Exploratory factor analysis for intensity of competition.....	8-9
Table 8.5	Exploratory factor analysis for total quality management (TQM).....	8-10
Table 8.6	Exploratory factor analysis for just in time manufacturing approaches (JIT).....	8-11
Table 8.7	Exploratory factor analysis for the extent of performance measurement diversity usage (PMD).....	8-13
Table 8.8	Exploratory factor analysis for satisfaction.....	8-18
Table 8.9	Descriptive statistics for research variables relating to the extent of performance measurement diversity usage (N = 163).....	8-20
Table 8.10	Descriptive statistics for research variables relating to the extent of balanced scorecard usage (N = 49).....	8-20
Table 9.1	Correlation coefficients of the extent of balanced scorecard usage and factors influencing the extent of balanced scorecard usage (Pearson)....	9-26
Table 9.2	Regression analysis for the contingent variables influencing the extent of balanced scorecard usage (BSCUSE).....	9-27
Table 10.1	Summary of the research hypotheses relating to factors influencing the extent of performance measurement diversity usage.....	10-10
Table 10.2	Summary of the research hypotheses relating to factors influencing the extent of balanced scorecard usage.....	10-13

List of Figures

Figure 2.1	Summary of factors affecting the evolution of performance measurements.....	2-12
Figure 2.2	The performance measurement matrix.....	2-30
Figure 2.3	The performance pyramid.....	2-32
Figure 2.4	The EFQM model.....	2-34
Figure 2.5	Links between performance measures, strategy and actions.....	2-37
Figure 3.1	The balanced scorecard.....	3-4
Figure 3.2	Managing strategy.....	3-9
Figure 4.1	A model for contingency research on management accounting system design.....	4-9
Figure 4.2	A general management control system contingency framework.....	4-10
Figure 4.3	Framework for assessing environmental uncertainty.....	4-26
Figure 5.1	The first research theoretical model.....	5-4
Figure 5.2	The second research theoretical model.....	5-8
Figure 8.1	Confirmatory factor analysis for business strategy.....	8-5
Figure 8.2	Confirmatory factor analysis for organisational structure.....	8-6
Figure 8.3	Confirmatory factor analysis for perceived environmental uncertainty (PEU).....	8-8
Figure 8.4	Confirmatory factor analysis for intensity of competition.....	8-9
Figure 8.5	Confirmatory factor analysis for total quality management (TQM).....	8-11
Figure 8.6	Confirmatory factor analysis for just in time manufacturing approaches (JIT).....	8-12
Figure 8.7	Confirmatory factor analysis for the extent of performance measurement diversity usage (PMD).....	8-14
Figure 8.8	Second-order confirmatory factor analysis for the extent of performance measurement diversity usage (PMD).....	8-14
Figure 8.9	Confirmatory factor analysis for satisfaction.....	8-19
Figure 8.10	The overall structural model for testing the first set of research hypotheses.....	8-27
Figure 9.1	Hypothesised model of the relationship between cost strategy and PMD.....	9-3
Figure 9.2	Hypothesised model of the relationship between differentiation strategy and PMD.....	9-5
Figure 9.3	Hypothesised model of the relationship between centralisation and PMD.....	9-6

Figure 9.4	Hypothesised model of the relationship between formalisation and PMD.....	9-8
Figure 9.5	Hypothesised model of the relationship between operational-peu and PMD.....	9-9
Figure 9.6	Hypothesised model of the relationship between raw material-peu and PMD.....	9-9
Figure 9.7	Hypothesised model of the relationship between regulatory-peu and PMD.....	9-10
Figure 9.8	Hypothesised model of the relationship between market competition and PMD.....	9-12
Figure 9.9	Hypothesised model of the relationship between product competition and PMD.....	9-12
Figure 9.10	Hypothesised model of the relationship between size and PMD.....	9-14
Figure 9.11	Hypothesised model of the relationship between total quality management and PMD.....	9-15
Figure 9.12	Hypothesised model of the relationship between just in time and PMD.....	9-16
Figure 9.13 (Model 1)	Coalignment model of contingent variables and PMD on organisational performance.....	9-18
Figure 9.13 (Model 2)	Coalignment model of contingent variables and PMD on organisational performance.....	9-19
Figure 9.14 (Model 1)	Coalignment model of contingent variables and PMD on satisfaction.....	9-21
Figure 9.14 (Model 2)	Coalignment model of contingent variables and PMD on satisfaction.....	9-22

Chapter 1

Introduction

1.1	Introduction.....	1-2
1.2	Background to the study.....	1-2
1.3	Research aim and objectives.....	1-5
1.4	Alternative management accounting research.....	1-5
1.5	Research contribution.....	1-11
1.6	Structure of the thesis.....	1-12

Chapter 1

Introduction

1.1 Introduction

This chapter aims to explain the rationale for conducting this study and to provide a general introduction to the thesis. Section 1.2 provides a background to the study and the motivation for undertaking it. Section 1.3 presents the research aim and objectives. The alternative management accounting research approaches are presented in section 1.4. Section 1.5 highlights the contribution of the current study. Finally, section 1.6 presents the structure of the thesis.

1.2 Background to the study

A review of the management accounting literature emphasised the importance of results controls as a fundamental element in the process of management accounting. This type of control concentrates on collecting and reporting information about an organisation's actions. All organisations are concerned with using accounting information to help managers make rational decisions in order to attain organisational objectives. However, the management accounting performance measurement systems which fall within the results controls category play a critical role not only on the monetary success of organisations, but also for their importance as a source to provide relevant information about internal activities.

The performance measurement system is one of the crucial areas of management accounting which is utilised to evaluate, control and improve processes through comparing the performance of different organisational levels. Despite its importance to organisations, this topic has been relatively less developed or investigated in the management accounting literature (Drury, 2004). This has been criticised in Johnson and Kaplan's (1987) publication 'Relevance Lost'. They indicate that from the 1950s to the 1980s management accounting information has been too late, too aggregated, and too distorted to be relevant for managers' planning and control decisions. Johnson and Kaplan place some of the blame for this lack of relevance on business schools and academic accountants (Scapens, 1991, p. 215). Since this publication, academics, accountants in businesses and consultants have sought to develop new management accounting systems and advanced management accounting techniques to

provide managers with relevant information to cope in today's environment (Burns and Vaivio, 2001).

Until recently, the literature on management accounting emphasised the use of financial performance measures in performance measurements and evaluation purposes. In recent years most organisations have faced changes in their environment. These changes are characterised by a highly competitive business environment, technological innovations and the emergence of new management practices such as a just in time management philosophy and total quality management practices. This has led management accounting researchers (e.g. Atkinson et al., 1997; Ittner and Larcker, 1998a; Neely, 1999; Otley, 1999; Norreklit, 2000) to criticise relying excessively on financial performance measures. As a result, the literature of the 1990s advocates that organisations should use a combination of both financial and non-financial performance measures to provide managers with the appropriate information about their overall organisation situation. In this context, Burns and Scapens (2000, p. 3) state that:

The environment in which management accounting is practised certainly appears to have changed, with advances in information technology, more competitive markets, different organizational structures, and new management practices (see for example Ezzamel et al., 1993, 1996). Although some might claim that the fundamental nature of management accounting systems and practices has not changed (e.g. Drury et al., 1993), there is evidence that the use of accounting within the management process has changed (Bromwich and Bhimani, 1989, 1994). Managers now appear to be using their accounting systems and routine financial reports more flexibly, and in conjunction with a range of other performance measures, both financial and non-financial (Miller and O'Leary, 1993).

Despite the increasing emphasis placed on including non-financial performance measures, many recent papers in management accounting journals have asserted the need for undertaking more studies on both the use and importance of performance measurement systems (Ittner and Langfield-Smith, 1998a; Vavio, 1999; Sandt et al., 2001). More specifically, these papers called for examining the importance of financial and non-financial performance measures and their perceived use in performance measurements and evaluation purposes. In addition, a contingency theory framework has been widely used in management accounting research but this stream of research has generally investigated the impact of few contingent variables relating to performance measurement systems. Thus, several researchers (e.g. Francis and Minchington, 2000; Ittner and Larcker, 2001; Speckbacher et al., 2003; Maltz et al., 2003) suggest the need to undertake more research to examine the impact of

several contingent variables on the design and use of performance measures. These suggestions provided further insights for studying performance measurement systems.

In the 1990s different performance measurement frameworks have been developed by management and management accounting researchers (a detailed review of these frameworks is presented in Chapter 2). However, the literature review on these performance measurement frameworks has revealed that the balanced scorecard is the most dominant framework in management accounting. Widespread interest in the balanced scorecard has been evident from an inspection of both the professional and academic publications, and this has resulted in an increasing rate of adoption among companies worldwide.

Even though there has been a considerable number of studies' relating to the balanced scorecard, there were several factors that provoked further research in this area. First, the level of implementation between organisations appears to be different and needs more investigation (see for example Olve et al., 1999; Malmi, 2001). Several types of balanced scorecard approach exist (Kaplan and Norton, 1996c). In both theory and practice several terms exist to describe the characteristics of this approach. Hence, there is no reliable statement that can show the degree to which the balanced scorecard has been implemented (Speckbacher et al., 2003). Second, many of the balanced scorecard concepts and relationships are open to different interpretations (Ax and Bjornenak, 2005), and this has resulted in confusion in interpreting the findings of recent empirical research. Third, many of the balanced scorecard studies have tended to be concerned with forwarding theoretical arguments or case studies. Fourth, most of the balanced scorecard research has been conducted outside the UK. It is therefore appropriate in this stage to investigate the application of this approach within a UK environment. Fifth, only few empirical studies have investigated the balanced scorecard using a contingency theory framework, even though management accounting researchers (e.g. Atkinson et al., 1997; Otley, 1999; Chenhall, 2003; Davis and Albright, 2004) have recommended conducting further balanced scorecard research drawing off the contingency theory framework. These statements provided further motivations for studying the balanced scorecard approach rather than other performance measurement frameworks.

Finally, the lack of knowledge on performance measurement systems use and their implications and the need for systematic research on a specific performance measurement

system (i.e. the balanced scorecard) have provided the motivation for conducting the current research. Thus, this research investigates the performance measurement systems operated by UK manufacturing companies. In addition, this research utilises the contingency theory theoretical framework for studying the extent of performance measurement diversity usage (i.e. financial and non-financial performance measures) and the extent of balanced scorecard usage through examining the impact of several contingent variables on the extent of both performance measurement diversity and balanced scorecard usage. It also examines whether a fit between the contingent variables¹ and the extent of performance measurement diversity usage is associated with greater organisational effectiveness.

1.3 Research aim and objectives

The research aims to achieve the following objectives:

1. To ascertain the extent of usage of broader set of financial and non-financial performance measures and their implications in UK manufacturing companies.
2. To determine the relationship between various contingent variables and the extent of performance measurement diversity usage.
3. To examine the relationship between the contingent variables, the extent of performance measurement diversity usage and organisational effectiveness.
4. To ascertain how UK manufacturing companies apply the balanced scorecard approach.
5. To determine the relationship between various contingent variables and the extent of balanced scorecard usage.

1.4 Alternative management accounting research approaches

Ryan et al. (2002, p. 70) indicate that the management accounting literature expanded in the 1960s, as researchers developed and refined new techniques to provide managers with appropriate accounting information, but by the late 1970s and early 1980s, researchers were beginning to identify a gap between theory and practice, as many of the techniques appeared to be little used in practice (see Scapens, 1991). This gap has affected management accounting research in two ways. First, there was increasing interest in studies that explored the nature of management accounting practices. Second, several changes took place in the methodology of management accounting research. Nevertheless, the literature review relating

¹ The terms contingent variables and contextual factors will be used interchangeably in this study.

to management accounting research traditions indicated the existence of several approaches to management accounting research. According to Scapens (1991) and Ryan et al. (2002) these approaches can be categorised² as follows:

1. Economic-based management accounting research.
2. Behavioural accounting research.
3. Research drawing off organisational theory.
4. Research drawing off social theory.
5. Practice-oriented research.

1. Economic-based management accounting research

Prior to the 1970s, the mainstream of research in management accounting was based mainly on the normative neoclassical economic framework (Scapens, 1991). This stream of research came from the recognition that accounting information should be appropriate for management decision-making (Ryan et al., 2002). The assumptions of neoclassical economic framework were based on the idea that decision-makers are assumed to have all the information required at no cost and with no uncertainty (Scapens and Arnold, 1986). It was also assumed that individual decision-makers could perform in isolation from other decision-makers within the organisation, so that group decision-making was not considered.

In the early 1970s, researchers started to extend the neoclassical economic framework to incorporate uncertainty through the application of statistical decision theory. However, information was still considered to be available at zero cost. By the mid of 1970s, researchers began to consider information economics in examining decision models (Scapens, 1991, p. 93). This was described as the 'costly truth' approach, in which truth is assumed to vary across situations based on the cost and benefits of information. This implied that truth can be obtained, and that a preferred accounting system does exist depending on the situation (Ryan et al., 2002, p. 74).

Thus, the application of this approach encouraged researchers to change their emphasis to become more concerned with explaining the reasons for observed management accounting

² It should be noted that the above categorisations represent broad general classifications so different views exist between researchers as to the appropriate classification. However, there will be common agreement on some of these classifications but other research has the potential to be categorised within more than one of the above classification.

practices (Ryan et al., 2002). During the 1980s anecdotal evidence suggested that there was a wide gap between the theory and practice of management accounting (Scapens, 1991). This also encouraged researchers to develop theories to seek to explain observed practices, and this represented a change of emphasis from normative to positive management accounting research (Ryan et al., 2002). The positive theories were grounded in empirical data and focused on either explanation or prediction. Agency theory emerged as a mechanism for explaining observed accounting practices. This approach separates the decision-maker from the owner. It assumes that decision-makers are allowed to choose particular courses of action based on their desires, needs, preferences, etc., and according to their understanding of how the world works (Jensen, 1983; Watts and Zimmerman, 1986). However, these developments did not challenge the underlying economic basis of management accounting because both decision-makers and owners were still assumed to behave in a rational economic way concentrating on maximising their personal utilities (Ryan et al., 2002). Agency theory became prominent in both neoclassical economics and positive forms. In management accounting however, researchers are normally concerned with the behaviour of individual firms, and of individuals within firms. Consequently, positive theories informed by neoclassical economics might be useful for predicting general trends, but they will not be helpful in explaining individual behaviour (Ryan et al., 2002, p. 79). This dissatisfaction resulted in some researchers drawing off alternative approaches to research in management accounting.

2. Behavioural accounting research

This stream of research began in the 1960s by questioning the behavioural assumptions of management accounting, and through examining the impact of accounting control systems such as budgetary control techniques and their influence on individual behaviour and organisational performance (Ryan et al., 2002). This stream of research also attempted to identify the crucial variables that could be manipulated in the design and use of budgets so as to improve organisational performance. Because behavioural accounting research considered people as an important element in affecting the budget systems in organisations, researchers began to pay more attention to the general exploration of budgeting and management control systems within organisational contexts (Ryan et al., 2002). As a consequence, researchers showed an interest in organisation theory and particularly the contingency theory to conduct research in management accounting.

3. Research drawing off organisational theory

The contingency approach is one of the most important perspectives of organisation theory. This approach was developed in the early to mid of 1960s to investigate the influence of contingent variables on organisational structure. The development of contingency theory of organisational structure according to Waterhouse and Tiessen (1978) was through the work of several researchers, such as Burns and Stalker (1961) and Thompson (1967). A considerable amount of research has been conducted in management accounting and management control systems using the contingency theory framework. The contingency theory framework to management accounting is based on the assumption that there are no universally applicable management control and accounting systems, but the choice of an appropriate system will depend on the circumstances surrounding organisations (Otley, 1980; 1999).

In the mid of 1970s, the contingency theory approach had become widespread, arising from the work on behavioural and organisational aspects of management accounting (Otley, 1980). Several streams of contingency studies have been conducted to address the contingent nature of management accounting control systems. Recent research conducted by Chapman (1997) addressed the streams of contingency studies of accounting. Starting with the first stream, there is a well-established body of literature on the role of accounting information in performance evaluation (e.g. Hopwood, 1972; Otley, 1978). Building on the previous studies, Hirst (1981) went on to examine the relationship between a style of accounting and environmental uncertainty. This style of accounting is related to the budget constrained style of Hopwood (1972) and became known as 'Reliance on Accounting Performance Measures'. The second stream of research was concerned with how accounting systems might be affected by a variety of contingent variables examples include: Gordon and Miller (1976) and Waterhouse and Tiessen (1978). The contingent variables that have been used in previous research to explain and observe the characteristics of management control systems include categories relating to the external environment, competitive strategy, technology, type of business units and firm and industry characteristics.

The contingency theory framework research has mostly involved the use of cross-sectional studies (in which measures of the relevant variables are obtained by mail or interview-based questionnaires) and attempting to identify statistical relationships between the contingent variables and aspects of the management accounting control systems. Given that the core

objectives of this study are to utilise a contingency theory framework, the contingency theory of management accounting will be discussed in greater depth in Chapter 4.

4. Research drawing off social theory

It was not until the 1980s that this stream of research began to appear in management accounting research. This was due to the influential article by Burchell et al. (1980), who urged accounting researchers to incorporate insights from the social sciences and particularly the work of critical social theorists into their studies (Ryan et al., 2002, p. 86). The introduction of social theory has generated the interpretive and critical research approaches. The interpretive approach aims at understanding the social nature of accounting practices. This approach also seeks to interpret accounting practices within the context of wider social systems of which they are a part, and understand management accounting as a social practice. In contrast, the critical approach aims to go beyond just interpreting accounting practices within a social context by creating the conditions in which social change is made possible (Ryan et al., 2002). Much of the research using the critical approach is based on the writings of the French social philosopher Foucault, who argues that it is possible to understand better the development of modern society in terms of the power-knowledge relationship, and various researchers have used Foucault's method to re-interpret accounting history (Ryan et al., 2002). The influence of social theory on management accounting research has significantly extended our understanding of its broader organisational and social context. Research within this framework has re-evaluated the history of accounting. In particular, it has revealed its interested nature, challenged the claims to an inherent accounting rationality and neutrality and provided alternative insights into the functions of accounting (Ryan et al., 2002, p. 90).

5. Practice-oriented research

The aforementioned management accounting research approaches have concentrated on explaining management accounting practices through a particular theoretical framework. Since the late 1980s, a stream of research has been conducted to describe management accounting practices without developing or testing any existing theory. This stream of research seeks to understand the development and application of new techniques of cost management, non-financial performance measurement, strategic management accounting and so on (Ryan et al., 2002, p. 90). Much of this research consists of descriptive cross-sectional studies to identify the nature and form of management accounting practices, and the extent of

usage of new techniques. It initially emerged because of the identification of a perceived gap between the theory and practice of management accounting (Scapens, 1991). As a response to this gap practice-oriented research was therefore considered necessary to obtain a broad clear picture of several management accounting practices.

In another context, the publicity given to Johnson and Kaplan's (1987) criticisms of management accounting, and its lost relevance provided a further impetus for practice-oriented research. Kaplan (1998) has identified another aspect of research drawing off the practice-oriented approach. This aspect involves utilising case studies to identify and report innovative management accounting practices, such as activity-based costing, balanced scorecards and strategic management accounting (Ryan et al., 2002). As a result, Kaplan advocates conducting innovative research in order to refine these practices for more general use, and developing new theories that should be tested by other researchers.

In terms of balanced scorecard research, different approaches have been adopted for undertaking research. Some of the research can be categorised within the economic-based management accounting research category. This research has compared the financial performance of balanced scorecard adopters with non-adopters (e.g. Ittner, Larcker and Randall, 2003; Davis and Albright, 2004). Some balanced scorecard researchers have drawn off social theory to explain aspects of balanced scorecard. For example, Cooper and Ezzamel (2004) provided a social analysis of the core assumptions of the balanced scorecard. Balanced scorecard research has also adopted a contingency theory framework to examine the influence of few contextual factors on the adoption of balanced scorecard approach. Hoque and James (2000), for example, have investigated the influence of organisation size, product life-cycle and strength of market share on using the balanced scorecard. The majority of balanced scorecard research falls within the practice-oriented research. Cross-sectional descriptive studies have been conducted to determine the characteristics of balanced scorecard approach (e.g. Spechbacher et al., 2003). Case studies have also been widely used to describe balanced scorecard characteristics and the implementation processes and problems (e.g. Malmi, 2001).

In terms of this research the first and fourth objectives (see Section 1.3) can be classified as descriptive practice-oriented research and the remaining objectives are achieved by adopting a contingency theory theoretical framework.

1.5 Research contribution

The contribution of this study to management accounting research in general and performance measurement systems in particular is inherent in section 1.2. However, it is appropriate at this point to provide more discussion of the major contributions of this study.

First, this study extends prior management accounting research by examining a wide range of financial and non-financial performance categories. This study also responds to many calls from recent researchers (see Chapter 5, sub-section 5.2.1) to examine the extent to which these performance categories are important to long-term organisational success and the extent to which these categories are used in performance measurements and evaluation purposes. In addition, the contingency theory of management accounting (reviewed in Chapter 4) indicates that the empirical research conducted to date has examined the impact of few contingent variables. However, additional insights can be gained by considering additional contingent variables. Thus, business strategy, organisational structure, perceived environmental uncertainty, intensity of competition, organisation size, the extent of total quality management usage and the extent of just in time manufacturing approaches usage are considered in this study. Finally, this study responds to many calls from management accounting researchers (e.g. Otley, 1980; Otley and Wilkinson, 1988; Chenhall, 2003) to include organisational effectiveness. Thus, two dimensions of organisational effectiveness are considered in this study (financial and non-financial indicators and the level of satisfaction). The inclusion of organisational effectiveness in the research theoretical model (see Chapter 5) resulted in the need to utilise advanced analytical statistical technique (structural equation modelling). Structural equation modelling is considered the most appropriate technique for testing complete contingency models (a detailed review of structural equation modelling is presented in Chapters 6 and 8). Recently, management accounting researchers (e.g. Ittner and Larcker, 2001; Chenhall, 2003) have called for utilising more rigorous statistical techniques such as structural equation modelling in order to enable more confidence to be applied to the results.

Second, this study provides an answer to the recent calls from several management accounting researchers to develop and adopt an accurate and comprehensive definition for the extent of balanced scorecard usage (e.g. Otley, 1999; Chenhall, 2003), rather than the earlier definitions utilised in the previous studies. For instance, several empirical studies (e.g.

Speckbacher et al., 2003; Ittner, Larcker and Randall, 2003) have defined the level of balanced scorecard usage by using a self-rating question (i.e. categorical dichotomy). Other studies (e.g. Hoque and James, 2000) have defined the level of balanced scorecard usage by using only the four financial and non-financial perspectives of the original balanced scorecard. These definitions however do not provide a comprehensive description of the extent of balanced scorecard usage. For example, using the categorical dichotomy as a measure of balanced scorecard usage (i.e. balanced scorecard users and non-users) treats the balanced scorecard companies as homogeneous, while in practice the level of usage of balanced scorecard is different between companies. Moreover, using only financial and non-financial performance perspectives as a measure of balanced scorecard usage does not necessarily imply that the companies are balanced scorecard users. Thus, this study contributes to the balanced scorecard literature by utilising several steps to ensure that the responding companies are really balanced scorecard users (a detailed review is presented in Chapters 5 and 8). Finally, most of the balanced scorecard studies (reviewed in Chapter 3) have been conducted in the USA, while little empirical research has been conducted in the UK. With respect to differences in the results across countries, it is of interest to compare whether the results of this study, particularly the balanced scorecard implementation stage, are similar to the results reported in the USA and other European countries.

1.6 Structure of the thesis

In addition to this chapter, the thesis comprises nine further chapters. Chapter 2 introduces the subject of management control and provides a broad overview of the performance measurement systems. This overview provides insights into the evolution of performance measurements over the last century up until today. However, the main aim of this chapter is to provide a better understanding of the main themes and arguments that support incorporating non-financial performance measures. In particular, emphasis is given to describing the performance measurement frameworks, strategic performance measurement systems and the new financial performance measures. Finally, the chapter describes why academics and practitioners have become increasingly interested in the balanced scorecard approach.

Chapter 3 focuses on the balanced scorecard approach. It provides a detailed description of the emergence of this approach and its assumptions. This chapter also reviews the relevant

literature on the balanced scorecard. Most of the studies reviewed are those that have either described the popularity of this approach or discuss the theoretical assumptions behind this approach. The literature review of the balanced scorecard indicates that very few empirical studies have adopted the contingency theory framework. Thus, Chapter 4 provides a better understanding of the main themes and arguments of the contingency theory and sets the foundations for undertaking a critical evaluation of the contingency theory of management accounting. This chapter starts with a brief overview of the early contingency theory of organisational structure. It then introduces the contingency theory of management accounting and control systems and the contingent variables used in the management control contingency studies. This is followed by a review of the limitations of contingency theory studies. Finally, the chapter ends with a discussion of the contingent variables that will be investigated in this study and their relationship with performance measures and the balanced scorecard.

Chapter 5 develops and justifies the research theoretical model and formulates the hypotheses that will be investigated in this study. The theoretical model includes several interrelated parts. They are the contingent variables, the extent of performance measurement diversity usage, the extent of balanced scorecard usage and organisational effectiveness. Because two aspects are examined (the extent of performance measurement diversity usage and the extent of balanced scorecard usage) the decision was made to divide the overall research theoretical model into two models. The first theoretical model presents a conceptual framework for understanding the extent of performance measurement diversity usage and their outcomes and the second presents a conceptual framework for understanding the extent of balanced scorecard usage. Finally, the operational definitions for each variable incorporated in the two theoretical models and the research hypotheses are presented.

Chapter 6 describes the research methodology and design, and the data collection methods utilised to achieve the research objectives. This is followed by a detailed discussion of the research population and sampling procedures. The chapter continues with a description of the stages of the questionnaire construction and pre-testing, features of the covering letter and the final content of the questionnaire. The survey administration and response profile are then presented, followed by a description of the non-response bias tests. The chapter concludes with a discussion of the statistical methods that are used to analyse the data.

Chapters 7 – 9 represent the data analysis procedures. Chapter 7 is concerned with the descriptive analysis of the research variables, including a thorough discussion relating to two of the five objectives listed in section 1.3. Chapter 8 describes the operationalisation of the research variables and their validity reliability assessments using both exploratory and confirmatory factor analysis. It also describes the statistical methods used for testing the research hypotheses. Chapter 9 reports and interprets the results of the statistical analysis pertaining to research hypotheses. Finally, Chapter 10 summarises the major findings of this study. In addition, implications and limitations of the study as well as possibilities for further research are presented.

Chapter 2

Performance measurement systems

2.1	Introduction.....	2-2
2.2	Management control.....	2-3
2.3	Performance measurement systems: Definition and design.....	2-6
2.4	The development of performance measurements.....	2-11
2.5	Financial performance measurements.....	2-13
2.6	Limitations of financial performance measurements.....	2-14
2.7	The changing basis of performance measurements.....	2-16
2.8	Non-financial performance measurements.....	2-18
	2.8.1 Non-financial performance measurements as leading indicators.....	2-22
	2.8.2 Non-financial performance measurements and manufacturing practices.....	2-24
	2.8.3 Non-financial performance measurements and compensation plans.....	2-25
	2.8.4 Notions and boundaries of non-financial performance measurements.....	2-26
2.9	Integrated performance measurement frameworks.....	2-28
	2.9.1 The performance measurement matrix.....	2-29
	2.9.2 The performance measurement questionnaire.....	2-30
	2.9.3 The performance pyramid model.....	2-31
	2.9.4 The performance measurement system for the service industry.....	2-32
	2.9.5 The EFQM business excellence model.....	2-34
	2.9.6 The performance prism.....	2-34
	2.9.7 The tableaux de bord.....	2-35
	2.9.8 The balanced scorecard.....	2-36
2.10	Strategic performance measurement systems.....	2-36
2.11	New financial performance measurements.....	2-38
	2.11.1 Economic value added.....	2-38
	2.11.2 Cash flow return on investment.....	2-39
2.12	The choice of strategic performance measurement system.....	2-40
2.13	Summary.....	2-41

Chapter 2

Performance measurement systems

2.1 Introduction

Accounting information plays a vital role in providing internal and external users with financial and non-financial information. The ability of organisations to compete successfully crucially depends on the availability of information upon which managers can act effectively. Information that is used for planning and controlling business activities is mainly provided by the management accounting function. Performance measurement systems are one of the important areas of management accounting that plays a major role in evaluating the achievement of organisational objectives (Medori, 1998). Thus, a review of the literature shows an increasing emphasis on the design and development of performance measurement systems.

Until recently, the management accounting literature emphasised the use of financial performance measures to enhance organisational strategy and to evaluate managerial performance (Otley, 1999; Hoque and James, 2000). Due to the emergence of today's highly competitive business environment, many changes and developments have occurred arising from the use of new technologies such as the adoption of total quality management and just in time manufacturing approaches. These changes have created a need for improved performance measures in order to sustain a continuous improvement (Kim et al., 1997; Chenhall, 1997; Kaplan, 1998; Hoque et al., 2001). Additionally, the increasing criticisms that have been made by several researchers (e.g. Eccles, 1991; Neely, 1999) relating to relying excessively on financial performance measures have resulted in additional emphasis being given to the use of non-financial performance measures such as quality and customer satisfaction. Recently, new financial performance measures such as economic value added and cash flow return on investment have also attracted a considerable amount of interest in management accounting literature (Ittner and Larcker, 1998a).

The main purpose of this chapter is to demonstrate the importance of performance measurement systems by providing an overview of their development based on a review of the management accounting literature. In addition, the chapter aims to demonstrate the

importance of financial and non-financial performance measurements by providing an overview of the different approaches suggested by researchers towards adopting integrated performance measurement frameworks including the adoption of the balanced scorecard. This chapter is structured as follows: Sections 2.2 and 2.3 discuss the definitions and design of management control and performance measurement systems. Section 2.4 continues with a description of the developments in performance measurement. Financial performance measurements are presented in section 2.5. This is followed by section 2.6, which introduces the limitations arising from excessively relying on financial performance measurements. Section 2.7 reviews the changing basis of performance measurements. Section 2.8 draws attention to the need for non-financial performance measurements and sections 2.9, 2.10 and 2.11 discuss the integrated performance measurement frameworks, strategic performance measurement systems and new financial performance measurements. The choice of strategic performance measurement is presented in section 2.12. Finally, section 2.13 provides some concluding remarks of the chapter.

2.2 Management control

This section embeds the use of performance measurements in the management accounting and management control literature. Generally, management accounting is concerned with preparing information for internal use, and its overall purpose is to help managers evaluate results and make rational decisions. The main function of management accounting is to cover a wide range of activities such as financial planning, financial transactions and providing management with an evaluation of expenditure on property and people. Therefore, management accountants play an important role in measuring and communicating financial information. According to Medori (1998), management accounting is usually divided into the following areas:

1. Investment analysis, which is concerned with making the investment decisions by using a number of techniques (e.g. payback period, internal rate of return and net present value).
2. Pricing decisions: these decisions require information about the cost of products.
3. Integration between financial accounts and management accounts: this area rotates around the valuation of stocks.
4. Budgeting, which provides a plan for achieving organisation strategy and as a mechanism for performance measurement.

5. The performance measurement system, which is used to evaluate, control and improve processes. It is also used to compare the performance of different organisations, plants, departments, teams, and individuals.

The role of management accounting information in performance measurement systems became a central focus of much management accounting research. In this context, Otley (2001, p. 249) states that:

Thus, I think it can be fairly argued that much of the thrust of the 'new' management accounting has been centrally concerned with the issues of measuring and managing organizational performance.

The management accounting system is considered a subsystem within the control system of organisations (Chia, 1995). The concept of control¹ is one of the key functions of management. The term is defined in an infinite number of ways in the literature, and many different control mechanisms are used in organisations. According to Langfield-Smith (1997, p. 208), controls have been categorised in many ways. For example, formal and informal controls (Anthony et al., 1989), output and behaviour controls (Ouchi, 1977), market, bureaucracy and clan controls (Ouchi, 1979), administrative and social controls (Hopwood, 1976) and results, action and personnel controls (Merchant, 1985). Recently, Merchant (1998, p. 2) indicated that controls are devices that managers use to ensure that the behaviours and decisions of people in the organisation are consistent with the organisation's objectives and strategies. This control process is cybernetic². He also classified controls into:

1. Action (or behavioural) controls: These types of controls are applied to situations where the actions and behaviour of individuals as they go about their work are the focus of control.
2. Personnel and cultural (or clan and social) controls: This category of control is based on strengthening the sense of commitment towards achieving organisational objectives, so that people can become incorporated with the interests of the organisation.

¹ Drucker (1964) distinguishes between controls and control. Controls are measurement and information that encompasses all the methods and procedures that direct employees towards achieving the organization objectives, while control is the function that makes sure that actual work is done to achieve organization objectives (Drury, 2002, p. 593).

² Cybernetic control consists of the following elements: (1) set goals, (2) measure performance, (3) compare performance with goals and (4) provide feedback to correct a variance between goals and performance (Otley et al., 1995).

3. Results (or output) controls: This type of control involves collecting and reporting information about the outcomes of the work efforts. The management accounting performance measurement system thus falls within this category of control.

Two different functions of control systems have been identified by Merchant (1998), strategic control and management control. Strategic control deals with the validity of the strategies of the firm in a changing environment. In contrast, management control deals with issues relating to influencing the behaviour of employees. According to Anthony (1965), management control is the process by which managers ensure that resources are obtained and used effectively and efficiently in the accomplishment of the organisation's objectives. Kaplan (1983) states that the purpose of the management control system is to provide information that is useful in planning, decision-making, control, and evaluation. Management control system consists of a collection of control mechanisms that have an internal focus. Drury (2002) argued that management accounting control systems are a form of result controls. These systems are mostly defined in monetary terms such as revenues, profits and ratios and may include non-accounting measures such as the number of customer deliveries. Drury (2002) also indicated that results controls involve the following stages:

1. Defining the performance dimensions in congruence with organisation's objectives.
2. Setting performance targets to specify every aspect of performance dimensions.
3. Measuring financial and non-financial performance.
4. Providing rewards or punishment.

As a consequence, the definition of management control systems has evolved over the years from one focusing on the provision of more formal, financial information to assist managerial decision making to one that adopts a much broader scope of information (Chenhall, 2003). However, the development of management accounting and control has evolved around activity-based costing systems, operational control systems and performance measurement systems (Kaplan, 1994, p. 247). Thus, performance measurement is central to the management control process for any organisation (Olson and Slater, 2002), and given this importance, this study focuses mainly on performance measurement systems.

To understand the performance measurement systems, it is necessary to be aware that financial and non-financial performance measurements are applied at different hierarchical levels within the organisation. At the lowest level (operational level) daily reports might be

provided that are likely to rely mainly on non-financial measures (e.g. number of defects, output quantities, etc.). At some middle organisational level, (responsibility centres³), managers should translate financial goals into operational goals. These managers' goals are primarily defined in financial terms, so their communications with their superiors are primarily in financial terms (Merchant, 1998, p. 73). In addition, responsibility managers are likely to be subject to responsibility reporting based on weekly or monthly variance accounting against the annual budget. The next level could be classified as the strategic business unit level typically consisting of divisions. Alternatively, for non-divisionalised companies this would represent the company as a whole. In this level, most of the key results areas are defined in financial terms (Merchant, 1998). Thus, a blend of financial and non-financial measurements is, in fact, needed at all organisational levels. It is crucial for senior managers to track not only financial measures, but also non-financial measures. Similarly, employees at lower levels need to understand the financial impact of their operating decisions (Anthony and Govindarajan, 2001, p. 443).

It should be noted that non-financial measures have been used for decades at the operational level but they have not been widely adopted at the strategic business unit level. However, most of the recent literature (e.g. Neely et al., 1996; Fullerton and McWatters, 2002) focuses on performance reporting at the strategic business unit level. Thus, this research focuses on performance measurements at the strategic business unit level. Finally, it should be noted that textbooks tend to advocate distinguishing between managerial and economic (strategic business unit) performance measures⁴. However, the evidence suggests that in practice the same performance measures (i.e. those for the strategic business unit) tend to be used for managerial evaluation purposes (Drury, 2002).

2.3 Performance measurement systems: Definition and design

Performance measurement systems play a key role in organisations, not only because of their effect on the monetary success of organisations, but also for their importance as a source of

³ A responsibility centre is a unit of a firm where an individual manager is held responsible for the unit's performance. It can be classified as a cost centre if only their costs are measured, as a revenue centre if only their revenues are measured, as a profit centre if both costs and revenues are measured and as an investment centre if both profits and investment used to generate these profits are measured (Drury, 2004, p. 653).

⁴ Managerial performance is concerned with measuring the performance of the strategic business unit manager or the divisional manager, while, economic performance is concerned with measuring the performance of the strategic business unit or the division (Drury, 2004).

information about financial transactions and the internal activities. Traditionally, the main sources of financial information have been the balance sheet, income statement and the cash flow statement (Yeniyurt, 2003). Organisations also use ratios as a method of assessing the financial performance. In order to achieve their objectives, organisations mainly depend on performance measures to evaluate, control and improve processes and to compare the performance of departments, teams, and to assess employees. In reviewing the literature on performance measurements, it was observed that this topic is often discussed but rarely defined. Even though, performance is an ambiguous term, and capable of no definition (Otley, 1999, p. 364), performance measurement has been defined in the literature by various writers. For instance, Marshall et al. (1999) define performance measurement as a development of indicators and collection of data to describe, report on and analyse performance. Amaratunga and Baldry (2003, p. 174) describe performance measurement as:

A process of assessing the progress towards achieving pre-determined goals, including information on the efficiency with which resources are transformed into goods and services, the quality of those outputs and outcomes, and the effectiveness of organizational operations in terms of their specific contributions to organizational objectives.

In a more comprehensive perspective, Neely et al. (1995) consider that performance measurement is a function of the efficiency and effectiveness of actions. Consequently, Neely et al. (1995) suggest three definitions of performance measurement:

1. The process of quantifying the efficiency and effectiveness of actions.
2. A metric used to quantify the efficiency and/or effectiveness of actions.
3. The set of metrics used to quantify both the efficiency and effectiveness of actions.

Many other definitions of performance measurement systems were identified in the literature review. Kaplan (1984) defined a performance measurement system as an information system that aims to provide financial signals in order to help management make decisions. Simons (2000) defines a performance measurement system as formal information-based routines and procedures that managers use to maintain or alter patterns in organisational activities. Browne and Devlin (2002) define performance measurement system as a complete set of performance measures and indicators derived in a consistent manner according to a set of rules or guidelines. Recently, Lohman et al. (2004, p. 268) provide definitions for four terms related to performance:

- A performance indicator or performance metric is a variable that express quantitatively the effectiveness or efficiency or both, of a part of or a whole process, or system, against a given norm or target.
- A performance measure is the activity of measuring performance using performance indicators.
- A performance measurement system is a system (software, databases, and procedures) to execute performance measures in a consistent and complete way.

The choice of performance measures and performance measurement system design is a critical challenge facing organisations (Neely et al., 1995; Ittner and Larcker, 1998a). In terms of the former, several researchers (e.g. Eccles, 1991; Kaplan and Norton, 1992; Lynch and Cross, 1995) have argued that most organisations face a difficulty in choosing their performance measures. In terms of the latter, some researchers (e.g. Globerson, 1985; Maskell, 1989) have developed criteria for designing performance measurement systems. For example, Globerson (1985) identified a set of criteria for performance measurement system design depending on several guidelines. The set of guidelines (quoted in Neely et al., 1995, p. 97) are:

- Performance criteria must be chosen from the organisation's objectives.
- The aim and calculation method of each performance criterion should be clear.
- The ability of performance criteria to be comparable with other organisations' criteria.
- Objective performance criteria are preferable to subjective ones.
- Data collection and methods of calculating the performance must be clearly defined.
- Performance criteria should be under control of the evaluated organisational unit.
- Ratio-based performance criteria are preferred to absolute number.
- Determining performance criteria should be selected through people who are involved in the organisation.

In the same vein, Maskell (1989) suggested the following group of principles of performance measurement system design (quoted in Neely et al., 1995, p. 97-98):

- The measures should be directly related to the firm's manufacturing strategy.
- Non-financial measures should be adopted.
- It should be acknowledged that measures change as circumstances do.
- The measures should be simple and easy to use.
- The measures should provide fast feedback.

- The measures should be designed so that they stimulate continuous improvement rather than simply monitor.
- It should be recognised that measures vary between locations-one measure is not suitable for all departments or sites.

As indicated by Neely et al. (1995), performance measurement system design can be analysed at three levels, which are:

- Individual performance measures level, which consists of the metrics to quantify the efficiency and/or effectiveness of actions. These metrics can be categorised under a number of headings such as quality, time, delivery, cost and flexibility.
- Performance measurement system level, which consists of a set of performance measures used to quantify both efficiency and effectiveness of actions as an entity (i.e. the performance measurement system).
- The performance measurement system and environment level, which illustrates the interaction between the performance measurement system with the internal and external environment.

Medori (1998) provided a comprehensive review concerning different criteria for designing performance measurement systems. In his review, he suggested four criteria depending on the most common attributes shared in designing performance measurement systems. These are: (1) the system should relate to organisation's strategy, (2) the system should be simple to understand, (3) the system should be non-financial but without excluding the financial measures, (4) the system should relate to customer requirements. Recently, Malina and Selto (2004, p. 446) indicated that management control and strategy theories identify eight desirable attributes of performance measures. These measures should be:

- Diverse and complementary.
- Objective and accurate.
- Informative.
- More beneficial than costly.
- Causally related.
- Strategic communication devices.
- Incentives for improvement.
- Supportive of improved decisions.

Subsequently, Atkinson, Waterhouse and Wells (1997, p. 30) indicate that the performance measurement system should:

- Help the company evaluate whether it is receiving the expected contributions from employees and suppliers, the element of its internal stakeholder group, and the expected returns from customer groups.
- Help the company evaluate whether it is giving each stakeholder group what it needs to continue to contribute so the company can meet its primary objectives.
- Help the company evaluate its planning and the contracts, both implicit and explicit, that it has negotiated with their stakeholders by helping it evaluate the effect of secondary objectives on its primary objectives.
- Guide the design and implementation of processes that contribute to the company's secondary objectives.

The criteria for designing performance measurements that have been reviewed so far provide general guidelines for setting up a performance measurement system. However, these criteria are also different from one organisation to another, some of them are easy to implement and others are less clear. In this context, Dumond (1994, p. 17) states that:

There is much written about performance measurement systems, but there is little consensus regarding definitions, methods of measurement, or even what should be measured.

Neely et al. (1995) suggested that the design criteria tend to have little underlying content, and there is no explanation on how these criteria can be applied. In the same vein, Neely et al. (1996) conducted a study to investigate the use of structured processes for the design of performance measurement systems in the UK. The findings based on a sample over 850 companies showed that 32% of the sample use structured processes for performance measurement system design, while 68% of the sample used informal processes. However, managers should be aware of the different interests of constituencies⁵ when designing and using performance measurement and control systems (Simons, 2000).

Given that there is no ideal criterion of performance measurement system design, the choice should be influenced by changes and developments in environment. These developments

⁵ Constituencies include owners, managers, employees, customers, suppliers, lenders and government agencies (Simons, 2000).

include linking performance measures to strategy in order to cope with the changes in both internal and external environment. Thus, the next section provides further discussion on the development of performance measurements.

2.4 The development of performance measurements

Performance measurements in organisations have generated much interest over the years in different business disciplines in different sectors. The developments in performance measurements have been strongly influenced by the increasing level of competition and the changing business environment (Johnson and Kaplan, 1987). Changes in the performance measurements have evolved and expanded for the past half century (Kaplan, 1983; Eccles, 1991; Kaplan, 1994; Ittner and Larcker, 1998a; Neely, 1999). Earlier, Kaplan (1984) indicated that the evolution of performance measurements began in the early 1900s by the ‘Dupont Company’ which devised the return on investment (ROI) as an accounting performance measure of the efficiency of the operating departments, and a measure of financial performance of the company as a whole. In this period, the company used the budgets to compare the actual and the budgeted ROI. The ROI became the only measure of success for many organisations (Johnson and Kaplan, 1987). Browne and Devlin (2002) highlighted that the financial performance measurements were developed in the late nineteenth and early twentieth centuries to meet the needs of manufacturing industries. These measurements were formalised in the 1930s and became the basis of performance measurement systems. In the 1940s, there was an extension incorporating residual income to the return on investment criteria. By the mid of 1950s, companies also started to use discounted cash flow. Johnson (1992) also argued that managing by the financials only became popular after the 1950s before which time senior managers used the financial figures for planning rather than control (quoted in Neely, 1999, p. 207).

Bourne et al. (2000) indicated that in the late 1970s and 1980s authors expressed dissatisfaction with traditional financial performance measurements. By the late 1980s and early 1990s this dissatisfaction led to the development of balanced or multidimensional performance measurement frameworks. In order to organise these developments, several researchers have divided these developments into several stages. For example, Ghalayini and Noble (1996) indicated that the development of performance measurements has had two stages:

- The first stage began in the late 1880s and went through the 1980s. In this stage, the main emphasis was on traditional financial performance measures such as profits, productivity, and return on investment.
- The second stage began in the late 1980s arising from changes in the market. Organisations started to face high levels of competition through quality and low cost. Therefore, organisations began to change their strategic priorities to cope with the high level of competition. Organisations also began to implement the new techniques in technology such as JIT and TQM. In this stage, organisations started to use non-financial performance measures such as quality, lead time and delivery and flexibility.

Kennerley and Neely (2002) raised another recent issue relating to the development of performance measurements. They indicated that in the mid 1980s there were remarkable changes in performance measurements, and these changes were related to the development of new technologies and the increasing complexity of organisations and markets. They also summarised factors affecting the evolution of performance measurements into two groups. The first group consists of factors that cause change and the second group consists of barriers to change. Figure 2.1 illustrate these factors.

Figure 2.1 Summary of factors affecting the evolution of performance measurements. Source: Kennerley and Neely (2002), p. 1227

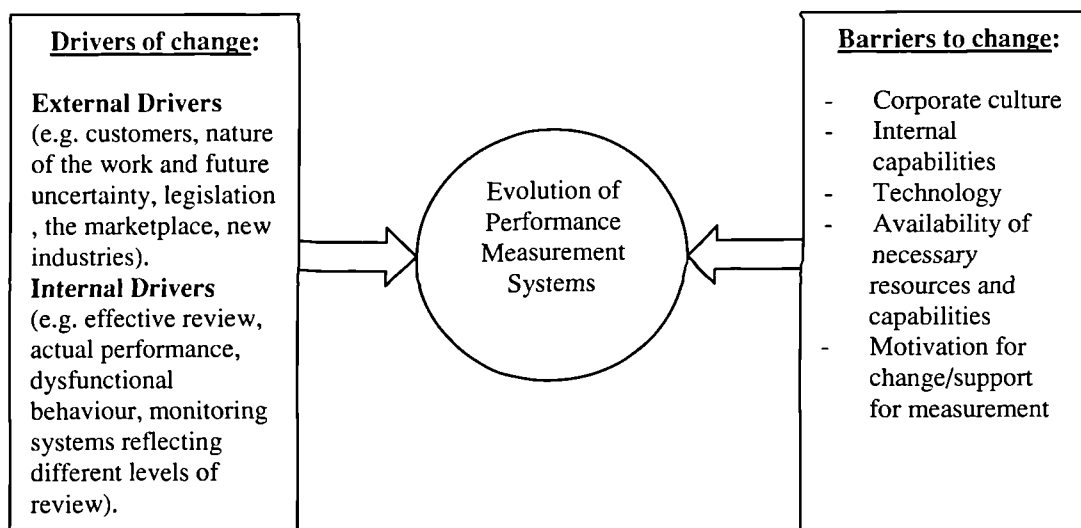

Kennerley and Neely (2002) stressed that performance measurement evolution and barriers to change have received little attention in the performance measurement literature. Recently, Kennerley and Neely (2003) argued that many organisations have redesigned their

performance measurement systems to ensure that they reflect their environment and strategies. The broad overview of the development in performance measurements discussed in this section revealed that organisations have expressed concern with traditional financial performance measurements until 1980s, but the use of these measurements differs between organisations. Thus, the next section will discuss the financial performance measurements.

2.5 Financial performance measurements

The American Accounting Association (AAA, 1975) defined financial performance measurements as pieces of information expressed in monetary units, ratios resulting from mathematical manipulations of information. Therefore, these measurements can be defined as performance measures expressed in monetary metrics (e.g. profits, budgets, ROI, market share), which provide financial information. Most organisations rely exclusively on financial measurements to identify the managerial and economic performance such as profits, accounting returns, budgets (Neely et al., 1995; Atkinson et al., 1997; Neely, 1999; Hoque and James, 2000; Browne and Devlin, 2002). In the same context, Chenhall and Langfield-Smith (1998a) indicated that financial performance measures are of primary importance in many countries. In the UK, a survey of the use of performance measures by board members and executives in 77 manufacturing firms found that financial measures such as working capital and financial returns are of primary importance (CIMA, 1993). According to a recent study conducted in the UK, companies still consider internal financial measures more important than external market measures (Yeniyurt, 2003, p. 137). In this vein, Burns et al. (2003, p. 7) state that:

UK managers today are more commercially oriented. This does not mean that profits are deemed unimportant-in fact, quite the opposite. But financial performance is placed in a much broader context and attention is given to the underlying factors that generate profits in the longer term. Such a commercial orientation usually emphasises the key performance indicators that measure the fundamental characteristics of the business associated with long-term profitability. These key performance indicators are often driven by strategic orientations, and frequently expressed in non-financial as well as financial terms.

The above discussion has indicated that traditionally budgets, variance analysis and financial performance measures have been used for decades as performance measurements. However, recent critics have argued that organisations should not rely only on these measures. The literature of the 1990s advocates the use of a combination of both financial and non-financial performance measures. This recommendation can be attributed to two reasons. First, the

limitations of financial performance measurements and second, the changing bases of performance measurements.

2.6 Limitations of financial performance measurements

In general, the publication of 'Relevance Lost' in 1987 by Johnson and Kaplan concentrated on the criticisms of management accounting. The authors claimed that management accounting practices that were developed in the 1920s had remained unchanged, and were still dominant in the 1980s. In addition, management accounting information was unsuitable for managers' planning and control decisions. Specifically, many limitations and problems associated with traditional financial performance measurements have been identified in the literature. These limitations relate to excessively focusing on the short-term through the use of measures such as profits, without considering longer-term performance measures such as quality and customer satisfaction. It is claimed that a major focus on short-term financial accounting measures may no longer provide an adequate indication of good performance for manufacturing companies (Kaplan, 1984; Maskell, 1989). In addition, various writers described the most important criticisms associated with traditional financial performance measurements during the 1980s and early 1990s. The following is a summary of the main criticisms:

- Traditional financial performance measurements are based on traditional management accounting systems. The most widely criticised practice is the allocation of overhead according to the direct labour cost. This practice encourages managers to concentrate only on minimising the direct labour cost while ignoring overhead (Kaplan, 1983; Johnson and Kaplan, 1987).
- The wide diversity in manufacturing strategies employed by organisations such as quality, flexibility, and customer satisfaction cannot be controlled or monitored by using only the traditional financial performance measurements (Ghalayini and Noble, 1996).
- Traditional financial performance measurements are lagging indicators because they are not particularly useful for management accounting reports and operational performance assessment (Maskell, 1989; Eccles, 1991).

Moreover, traditional performance measurements are no longer satisfactory for organisations that seek competitive advantage (Neely et al., 1995). In this context, Phillips (1999) provides evidence from a survey by the Institute of Management Accounting in 1996 that found only

15% of respondents' measurement systems satisfactorily supported senior manager's strategy objectives, whereas 43% were considered not to adequately support these objectives. The criticisms made against traditional financial performance measurements of accounting systems relate to financial measures focusing on historical information concerning past actions and a failure to focus on future attentiveness (Kaplan and Norton, 1996a). In this context, Neely (1999) indicates that financial performance measures are historically focused, for example, sales turnover reports, what happened last week, month or last year. Instead, managers require predictive measures that indicate what will happen in the future. Another major criticism is that financial performance measurements exclude non-financial performance measurements (Atkinson et al., 1997). Recently, researchers have criticised the traditional financial performance measurements for several reasons. For instance, Ittner and Larcker (1998a) criticise them for not considering the cost of capital and for being influenced by external reporting rules. Wouters et al. (1999) indicate that current profit and other financial performance measures only partially reflect the effects of past and current activities, and these measures are often too short-sighted. Other researchers such as Martinsons et al. (1999), Norreklit (2000) and Giannetti et al. (2002) have asserted that traditional financial performance indicators do not measure intangible assets.

It should be noted from the above discussion that numerous authors have discussed the problems associated with financial performance measurements. This broad overview led Ghalayini and Noble (1996) to classify the limitations of financial performance measurement into two main groups: specific and general. Specific limitations apply to certain performance measurements such as productivity, cost or profit. General limitations apply to all traditional performance measurements, these limitations are: (1) relying on traditional management and cost accounting systems, (2) providing information about past performance, (3) not incorporating business strategy, (4) not being appropriate to all organisational levels, (5) not useful for meeting customer needs, (6) many improvements are difficult to quantify in financial terms.

In response to the above criticisms, many academics, consultants and professionals advocated the necessity to use non-financial performance measurements (Keegan et al., 1989; Lynch and Cross, 1995). In addition, several changes have contributed to the evolution of performance measurements and resulted in the need to use non-financial performance measures. These changes will be addressed in the next section.

2.7 The changing basis of performance measurements

Before discussing the changing bases of performance measurements, it is of crucial importance to highlight the developments in management accounting. According to Otley (2001), these developments could be achieved through implementing the following changes:

- Moving from historical point of view to forward looking.
- Moving from control to planning.
- Moving from internal perspective to external perspective.
- Moving from cost to value.
- Moving from production to marketing.

Today many companies operate in a globally competitive environment, adopt the continuous improvement ideal, use new manufacturing practices such as total quality management, and just in time, and concentrate on the team-working and employee involvement. The challenge for this competitive environment is to develop new and flexible approaches to the design of effective performance measurement systems (Bititci et al., 2002). According to a recent survey, 55% of the respondents reported that they were in the process of changing their performance measurement systems (Frigo and Krumwiede, 1999, p. 42). Euske et al. (1993) indicated that performance measurement systems are a vital element of the change process in organisations. These changes have created the need for non-financial performance measures to be included in the performance measurement systems (Azofra et al., 2002). Earlier, Eccles (1991) highlighted the need for the following changes in performance measurements:

- The changing nature of work: The developments in the accounting systems particularly changing overhead allocation from direct labour to activity-based costing system and new investments in process automation. These changes require modifications to the performance measurement systems.
- Increasing competition: Because of the intensive global competition, many organisations have emphasised quality and flexibility and concentrated on non-financial and financial factors in order to cope with the high level of competition.
- Improvement initiatives: The increasing level of competition has resulted in many organisations giving more attention to new improvements such as total quality management, world class manufacturing, and quality costing. To cope with these new techniques, organisations have had to incorporate new performance measurements.

- Quality awards: Many organisations seek national and international awards and they have developed their performance measurements in order to compete for the quality awards.
- Changing organisational roles: The increasing criticisms of traditional financial performance measurements came from the professional accounting associations and academics. They have encouraged their members to take actions to improve the performance measurement systems.
- Changing external demand: Many organisations are subject to regulators demand to achieve certain performance measurement standards. These regulations have had an impact on the performance measurement systems of organisations.
- Information technology: The new technology has provided the potential to enhance the performance measurement systems by capturing data which previously had been difficult to access.

Butler et al. (1997) argued that both academics and practitioners are interested in performance measurement systems because of the following factors: (1) successful companies place less reliance on financial metrics and pay more attention to long-term strategic issues, (2) the failings of conventional management accounting as indicated by Johnson and Kaplan, and (3) the rise of the total quality management and the revolution in information technology. Drury (1997) indicated that many organisations monitor the efficiency and effectiveness of activities performance measurements such as time-based measures, cost of activities and quality as a means of advancing competitiveness and managing costs. In the same vein, Ghalayini and Noble (1996) highlighted that time is proposed as the new strategic metric that organisations should use to measure and improve in order to be able to compete within changes in the market. The importance of measuring time is based on the view that it will increase quality, enhance delivery and improve responsiveness to customer's orders. Thus, in order to improve time performance measurements all operational measures should be considered. Kaplan and Norton (1996b) asserted that companies should exploit intangible assets such as high-quality products, skilled employees and satisfied customer and this help companies in:

- Developing customer relationships that retain the loyalty of customers and enable new customers to be served effectively and efficiently.
- Introducing innovative products and services.
- Producing high-quality products and services at low cost and with short lead times.

- Mobilising employees' skills and motivation for continuous improvements.
- Deploying information technology, databases, and systems.

Because of the new challenges facing organisations, the importance of using the non-financial performance measurements has been emphasised by researchers. For example, Kaplan (1984) indicated that in the 1980s, there was a need for non-financial performance measurements on quality, productivity, deliverability and flexibility in order to cope with the global competition. In response to the importance of including non-financial performance measurements, the following section presents a brief discussion of non-financial performance measurements.

2.8 Non-financial performance measurements

According to a publication by the American Accounting Association (1975), non-financial performance measurements are information expressed in non-monetary units and ratios. The use of non-financial measurements is a call for using the operations-based measures that are the origins of management accounting systems (Johnson and Kaplan, 1987). Maskell (1989) summarised non-financial measures into five categories: quality, delivery, production process time, flexibility and cost. These measurements are, however, not a new phenomenon. Du Pont and General Motors established the basis for non-financial performance measurements at the beginning of the 20th century. General Electric, for example, made use of non-financial performance measurements in the 1950s (Norreklit, 2000). The use of these performance measurements has become a subject of great interest particularly in relation to intensive competition, customer satisfaction, inadequacy of traditional measurements and the use of new manufacturing practices. Ittner and Larcker (1998a) suggest the following reasons for the use of non-financial performance measurements: (a) perceived limitations in the use of traditional financial measures, (b) increased competitive pressure, and (c) implementation of other programs like TQM. In addition, Medori and Steeple (2000, p. 521) summarise the following advantages of using non-financial performance measurements:

- The measures are more timely than financial ones.
- The measures are very measurable and precise.
- The measures are meaningful to the workforce so aiding continual improvement.
- The measures are consistent with company goals and strategies.
- The measures change and vary over time as market needs change.

As a consequence, many academic researchers (e.g. Bromwich and Bhimani, 1994; Horngren, 1995; Ittner and Larcker, 1998b) supported the inclusion of non-financial performance measurements in management accounting reports. Other researchers have argued that non-financial performance measures have been recently proposed as a means of overcoming the limitations of traditional financial performance measures (Eccles, 1991; Kaplan and Norton, 1992; Rangone, 1997; Ittner and Larcker, 1998a; Vaivio, 1999). It seems clear that there are wide differences between traditional ‘financial’ and non-traditional ‘non-financial’ performance measurements. These differences were identified and summarised by Ghalayini and Noble (1996). Thus, Table 2.1 shows these differences.

Table 2.1 A comparison between traditional and non-traditional performance measures. Source: Ghalayini and Noble (1996), p. 68

Traditional performance measures	Non-traditional performance measures
- Based on traditional accounting system	- Based on company strategy
- Mainly financial measures	- Mainly non-financial measures
- Intended for middle and high managers	- Intended for all employees
- Lagging metrics (weekly or monthly)	- On time metrics (hourly or daily)
- Difficult, confusing, and misleading	- Simple, accurate, and easy to use
- Lead to employee frustration	- Lead to employee satisfaction
- Neglected at the shopfloor	- Frequently used at the shopfloor
- Have a fixed format	- Have no fixed format (depends on needs)
- Do not vary between locations	- Vary between locations
- Do not change over time	- Change over time as the needs change
- Intended for monitoring performance	- Intended to improve performance
- Not applicable for JIT, TQM, FMS, etc	- Applicable
- Hinders continuous improvement	- Help in achieving continuous improvement

Empirically, Coates et al. (1993) found that few companies rely exclusively on financial measurements alone. All participating companies expanded the number of measurements to include the non-financial performance measurements. Their study focused on multinational companies based in the USA, the UK and in Germany (quoted in Letza, 1996, p. 56). In the same vein, Frigo and Krumwiede (1999) found that non-financial performance measurements were becoming predominant in performance measurement systems and should be used more extensively. Many academics, professionals, and consultants advocate the need to incorporate the non-financial performance measurements in manufacturing companies (Kaplan, 1983). In this context, Maskell (1989, p. 33) states that:

The day-to-day control of the manufacturing and distribution operations is better handled with non-financial performance measures.

The use of non-financial performance measurements ought to be considered by UK manufacturing companies as an important managerial tool (CIMA, 1993). Thus, several empirical studies have investigated non-financial performance measurement practices in manufacturing settings. For example, Drury et al. (1993) surveyed management accounting practices in 260 UK manufacturing companies. One of the results confirmed the importance of non-financial performance measurements, particularly customer satisfaction, product quality, delivery and supplier reliability. Booth (1997) indicated that research on more than 3000 companies in Europe and North America has shown that the strongest drivers of competitive achievement are the intangible assets such as quality, innovation, customers and employees. Moreover, a case study by Fisher (1995a) identified the weaknesses of traditional performance measurements. He identified the external environment and the recognition of business initiatives such as TQM as the main factors for the rapid growth in the adoption of non-financial performance measurements. According to Lingle and Schiemann (1996), Wm. Schiemann & Associates Inc. conducted a survey on the quality, uses, and the importance of a diversity of financial and non-financial performance measurements. They surveyed 203 executives from a variety of industries (65% manufacturing companies). Table 2.2 summarises the findings of this study.

Table 2.2 Quality, uses, and importance of financial and non-financial performance measures. Source: Ittner and Larcker (1998a), p. 207

Practices	Type of performance measures					
	Financial	Customer	Operating	Employee	Community/ Environment	Innovation/ Change
Information is highly valued*	82%	85%	79%	67%	53%	52%
Willing to bet job on the quality of information*	61%	29%	41%	16%	25%	16%
Measures clearly defined in each performance category*	92%	48%	68%	17%	25%	13%
Regular management review for measures**	98%	76%	82%	57%	44%	33%
Measures are used to drive organisational change**	80%	48%	62%	29%	9%	23%
Measures are linked to compensation**	94%	37%	54%	20%	6%	12%

*Percent of executives responding to the survey who agreed with this statement.

**Percent of respondents using these measures who agreed with this statement.

Stivers et al. (1998) conducted a survey in U.S. Fortune 500 companies and Canadian 300 companies to examine the use of non-financial performance measurements. Specifically, the study examined the importance of customer, market, innovation, employee and goal

achievement performance measurements, and whether these measurements were used in the planning process. The results showed the importance of customer, market and goal achievement measurements, whereas, innovation and employee measurements showed less importance in goal setting. Finally, the results suggested that, although non-financial performance measurements are viewed as important, they may not be measured. Even when non-financial measurements are measured, they may not be used in the planning process.

Based on a sample of 140 financial services firms, Ittner, Larcker and Randall (2003) examined the extent to which various performance categories (i.e. financial, customer, employee, operational, quality, alliances, supplier, innovation, community, and environmental performance) are important drivers of firms' long-term organisational success. In addition, the study investigated the performance measurement practices relating to the above performance categories in terms of setting strategic goals, evaluating capital investments, evaluating managerial performance, disclosing information to external parties, measurement quality, and identifying problems and developing action plans. In terms of the importance of performance categories to long-term organisational success, the study found that financial category was ranked fourth most important behind customer, quality and operational categories. Innovation, community, and employee categories also received relatively high importance scores, whereas, supplier and environmental performance categories were believed to be relatively unimportant. The study found that financial, customer, operational, and quality performance categories were used in all the above performance measurement practices (i.e. strategic goals, problem identification, capital investment, performance evaluation, external disclosure, and measurement quality). The study also found that employee, alliances, supplier, environment and community performance categories were not used in all performance measurement practices, while, innovation category was used only in capital investments decisions. Ittner, Larcker and Randall (2003) concluded that the importance of all non-financial performance categories to long-term organisational success is less than the anticipated use of these categories in performance measurement and decision-making. They also indicated that extensive use of performance measures for one managerial purpose does not necessarily imply that the measures are used for other managerial purposes.

Attempting to understand the initiatives of non-financial performance measurements and their economic benefits, Said et al. (2003) conducted a study to investigate whether the use of

non-financial measurements in compensation is associated with future accounting and stock market performance. The study also examined the relationship between the use of non-financial measurements and economic performance, as a function of the fit between a company's operational and competitive circumstances, and its choice of performance measurements. The empirical analysis conducted in this study was by comparing performance consequences of companies incorporating both financial and non-financial measurements versus companies using only financial measurements. The study found some evidence for future accounting-based performance. The overall evidence of the effect of non-financial measurements' on accounting-based performance was mixed. The results also showed that non-financial measurements usage were significantly associated with innovation strategy, quality strategy, the length of the product development cycle, industry regulation and the level of financial distress. Finally, the association between non-financial measurements and company performance was contingent on whether the use of these measurements matched the company's characteristics.

In another context, the AAA Financial Accounting Standards Committee investigated issues relating to the disclosure of non-financial performance measurements. The committee concluded that mandating a standard set of disclosures relating to customer satisfaction, quality, and the like would not best serve investors. Rather, the committee believed that companies should be encouraged to provide such disclosures voluntarily (Maines et al., 2002, p. 360). In the same vein, Cumby and Conrod (2001) conducted a study to investigate the extent to which Canadian biotechnology companies used and explored the non-financial information in their published information. The findings based on a sample of 19 companies showed that the biotechnology companies provided complete information in different areas, such as product development, employees, alliances, completeness and the market in addition to the financial information. Due to the importance of including non-financial performance measurements in management practices the following sub-sections present major empirical studies relating to non-financial performance measurements.

2.8.1 Non-financial performance measurements as leading indicators

Many arguments have been raised concerning the determination of non-financial performance measurements as leading indicators of financial performance. According to Otley (1997, p. 44):

Some recent research has indicated that companies that use non-financial performance measures appear to deliver better financial performance than those which rely solely on financial indicators.

Ittner and Larcker (1998a) argued that the improvements in different non-financial areas such as customer satisfaction, quality and innovation would affect future financial performance. A survey of vice presidents of quality for major US companies found that only 28% could relate their customer satisfaction measures to accounting returns, and only 27% to stock returns (Ittner and Larcker, 1998a). Moreover, Anderson et al. (1994) conducted a study to investigate the relationship between non-financial measurements and financial performance in 77 Swedish companies. They found that a higher customer satisfaction leads to a higher return on investment, after controlling the past returns and the time trend. Furthermore, Ittner and Larcker (1998b) found support for the claim that customer satisfaction measurements are associated with the company's current market value, but not with contemporaneous accounting measures. Srinivasan (1997) investigated the relationship between financial and non-financial performance measurements in the context of hotels. The study demonstrated that customer satisfaction measurements were significantly associated with future performance, in terms of revenues and profit (quoted in Hussain and Gunasekaran, 2002, p. 519).

An empirical benchmarking study conducted by Wouters et al. (1999) showed that it is possible to identify the non-financial performance measurements that are most clearly associated with financial performance. Banker et al. (2000) conducted a study to investigate the managerial incentive compensation plans based mainly on financial performance measurements, with the implementation of new incentive compensation plans that include non-financial performance measurements. Based on a sample of 18 hotel chains, the findings showed that customer satisfaction measurements were significantly associated with future financial performance, and that both financial and non-financial measurements enhance performance following the implementation of incentive plans. Nagar and Rajan (2001) conducted a study to investigate the implications of financial and operational measurements of quality. They found that both financial quality and non-financial quality measurements are significantly associated with future sales. Recently, Ittner, Larcker and Meyer (2003) found little evidence that the weights placed on non-financial measurements had any association with their ability to predict financial performance. Overall, academic research suggests that non-financial performance measurements are relevant for predicting future financial

performance (Maines et al., 2002). Furthermore, there is the view that non-financial measures are better predictors of company's long-term performance, and that they sustain managers in monitoring company's progress towards strategic objectives (Kaplan and Norton, 2001a).

2.8.2 Non-financial performance measurements and manufacturing practices

The increasing emphasis on new manufacturing systems has resulted in organisations concentrating on including quality and continuous improvement as strategic priorities (Kaplan, 1994). Particular challenges have been apparent in the manufacturing industry. These challenges have resulted in the emergence of several techniques such as just in time manufacturing approaches, total quality management, advanced manufacturing technologies and flexibility. Many researchers (e.g. Euske et al., 1993; Sim and Killough, 1998; Lillis, 2002; Hoque, 2003) have suggested that a consequence of such developments is the need to improve performance measurement. In this context, Ittner and Larcker (1995) examined the use of management accounting systems that include non-financial performance measurements and incentives related to performance measurements and their association with TQM usage. The findings of the study suggest that quality measurements are associated with the use of TQM practices. Moreover, Abernethy and Lillis (1995) reported a positive association between the emphasis placed on manufacturing flexibility and the provision of non-financial information. Perera et al. (1997) conducted a study to investigate the use of operations-based non-financial performance measurements in organisations implementing advanced manufacturing technologies and advanced management practices. The study examined whether organisations that maintained a customer-focused manufacturing strategy also emphasised non-financial performance measures, and if the emphasis enhanced organisational performance. Based on a sample of 105 manufacturing organisations, the findings of the study provided evidence of the increased usage of non-financial performance measurements by organisations pursuing a customer focused manufacturing strategy. This usage was stronger in organisations implementing advanced management practices compared to organisations implementing advanced manufacturing technologies, but the study was not able to find any relationship with the enhancement of organisational performance.

Kim et al. (1997) indicated that organisations seek to improve their activity performance by implementing new advanced manufacturing systems. Attempting to address the effect of new manufacturing systems, Chenhall (1997) investigated the relationship between reliance on

manufacturing performance measurements, total quality management and organisational performance. The researcher argued that a reliance on manufacturing performance measurements to evaluate managers' performance can enhance the profitability of companies pursuing total quality management. The results of the study supported the aforementioned argument. Research by Sim and Killough (1998) indicated that non-financial performance measurements, such as customer and quality measures are associated with companies implementing new manufacturing techniques such as total quality management and just in time manufacturing approaches.

2.8.3 Non-financial performance measurements and compensation plans

The management accounting literature has also focused on the relationship between performance measurements and the reward system (Atkinson et al., 1997). Many organisations have measured and rewarded managers by using traditional financial performance measurements such as return on investment or earnings (Eccles, 1991; Kaplan and Norton, 1992; Baber et al., 2002). Recently, Ittner, Larcker and Meyer (2003) stressed that compensations based solely on financial measurements have been criticised for encouraging managers to sacrifice long-term performance to increase short-term financial results. To overcome the aforementioned criticism, several researchers (e.g. Rappaport, 1999; Banker et al., 2000) emphasise linking non-financial performance measurements with executive compensation plans. In this context, Ittner et al. (1997) conducted a study using data from 317 companies to investigate the factors influencing the extent to which organisations depend on non-financial and financial performance measures in manager's bonus contracts. One of the findings of the research was that the companies following an innovation-oriented prospector strategy relied on non-financial performance measurements in determining annual bonus contracts more than companies following a defender strategy. Despite the increasing use of non-financial performance measurements in managerial compensation (Ittner et al., 1997), there is little empirical evidence of the impact of non-financial performance measurements on performance (Banker et al., 2000). In this context, Malina and Selto (2001) indicated that studies of the performance effects of including non-financial measurements in compensation plans revealed inconsistent relationships. Thus, they emphasise the need to conduct more research to explain the links between non-financial performance measurements and compensation plans.

2.8.4 Notions and boundaries of non-financial performance measurements

The previous sub-sections have reviewed the related literature about non-financial performance measurements. The first sub-section has summarised the papers that examined the relationships between financial and non-financial performance measurements. Generally, these studies support the idea that non-financial performance measurements can be indicators for current or future financial performance (e.g. Amir and Lev, 1996; Srinivasan, 1997; Ittner and Larcker, 1998b; Hughes, 2000). Studies, however, that have investigated the link between non-financial measurements and future financial performance have shown mixed results (Ittner and Larcker, 1998a). Moreover, the aforementioned studies do not provide any evidence on whether there are diminishing or negative returns concerning the use of non-financial measurements. Little evidence was available about a possible time lag between leading and lagging measures. Consequently, it is still necessary to address how the non-financial performance measurements are related to the achievement of profit enhancement and organisational objectives.

The literature has shown consistent evidence suggesting that using more non-financial measurements is associated with the adoption of manufacturing practices like total quality management and just in time manufacturing approaches. In contrast, linking non-financial performance measurements to managerial performance evaluation and reward system needs more investigation. Finally, the fact that different results were obtained from several studies may be explained by considering the different determinants of non-financial performance measurements used. Thus, further research should attempt to explain the objectives for using the non-financial performance measurements. The inadequacies of traditional financial performance measurements have led organisations to concentrate on the adoption of non-financial performance measurements, but these measurements also have disadvantages. They relate to the variety of non-financial performance measurements, and the problem arising from choosing the appropriate measurements given that there is no optimal mix of performance measurements. Moreover, measuring organisations' financial performance is implicitly simple, because there are rules and guidelines to determine the financial measurements. In contrast, the non-financial performance measurements cannot be related to the same rules or guidelines (Medori, 1998). However, the establishment of non-financial performance measurements should be linked to target settings, and reward and incentives also need to be considered (Otley, 1997). Within the management accounting literature, non-

financial performance measurements have been extensively examined. According to Neely (1999, p. 207), between 1994 and 1996, some '3615' articles on performance measurement were published. Each one of these studies either focused on a specific point in non-financial performance measurements or looked for the association with management strategy and reward system.

According to CIMA (1993, p. 86), no optimal set of measurements has yet emerged either in practice or theory to monitor the performance of manufacturing companies. The choice of appropriate performance measurements, however, is likely to be influenced by the intensity of competition and ensuring that customer satisfaction is taken into account. Earlier, Kaplan (1983) indicated that non-financial performance measurements are related to specific competitive dimensions such as customer satisfaction, and these are difficult to aggregate into a single overall measure. In the same context, Rangone (1997) highlighted that the wide variety of non-financial measurements can create a problem in determining the appropriate set of performance measurements. However, the issue of appropriate performance measurements is of particular importance because of their future impact on the financial success and their importance within the information system. A survey conducted by the Chartered Institute of Management Accountants (1993, p. 6) on performance measurement among manufacturing companies conclude that:

The issue of appropriate performance measures is highly significant because it can affect commercial success, and because in the present economic climate manufacturers will be looking for appropriate information about their internal processes to establish ways of cost cutting, of enhancing performance and generally of building a better product in a shrinking market. Manufacturers at this stage more than ever before are finding that the need for accurate and comprehensive information about their activities is intense.

In response to the debate relating to the advantages and disadvantages of considering the financial or non-financial performance measurements and the appropriate choice of measurements, some empirical evidence indicates that financial and non-financial measurements are not substitutes, but that non-financial measurements are used as additives to financial measurements (Govindarajan and Gupta, 1985). However, effective frameworks of performance measurements that integrate both financial and non-financial measurements have recently emerged. These frameworks are based on the fact that management accounting information systems cannot rely on financial measurements alone. A combination of financial and non-financial measurements is essential to give a more balanced impression of

the overall performance of the organisation. Many researchers (e.g. Nanni, et al., 1992; Kaplan and Norton, 1996a; Ittner and Larcker, 1998a; Hoque and James, 2000; Laitinen, 2002) have argued that the new developments in performance measurements have revolved around the integrated performance measurement frameworks, and the use of new financial performance measurements. In this context, Otley (2001, p. 255) states that:

However, accounting measures and non-financial performance measures are increasingly being integrated in real-world control practices, so it would be foolish to maintain an artificial distinction that no longer represents the reality of practice.

The professional accounting associations such as Chartered Institute of Management Accountants (CIMA) and Institute of Chartered Accountants of Scotland (ICAS) have also encouraged the use of integrated performance measurements in order to provide information to run the business effectively (Neely, 1999). In this context, Banerjee and Kane (1996) found that 85% of surveyed CIMA members believed that accountants need to integrate non-financial and financial information in their reporting. Recently, Ittner and Larcker (2003) conducted field research in more than 60 manufacturing and service companies, and supplemented it with a survey from senior executives. They found that most companies have made little effort to identify areas of non-financial measurements that might advance strategy, also they did not demonstrate a cause-and-effect link between improvements in non-financial measurements and financial performance. Instead, many companies have adopted versions of performance measurement frameworks such as balanced scorecard. Ittner and Larcker (2003) have also identified several common mistakes companies made when measuring non-financial performance measurements, such as not linking performance measurements to strategy, not validating the links between measurements and finally not setting the right performance targets. Consequently, companies should be encouraged to use models integrating financial and non-financial measurements (Maines et al., 2002). Therefore, several new performance measurement frameworks were developed in attempts to solve the problem in selecting non-financial measures (Medori and Steeple, 2000). The next section discusses the most popular performance measurement frameworks.

2.9 Integrated performance measurement frameworks

It was pointed out in the previous section that there is no single performance measurement for evaluating business performance (Stivers et al., 1998). Therefore, it is advocated that companies should adopt new performance measurement frameworks that present a balance of

both financial and non-financial performance measurements. Nanni et al. (1992, p. 17) emphasise the importance of integrated performance measurements. They state that:

Integrated performance measurement is used to manage work rather than costs. Where traditional approaches employed planning data to achieve control, integrated performance measurement uses measures to influence plans. It is a dynamic approach to finding a way, not a rigid approach based on knowing the desired end.

In the same vein, Booth (1997, p. 28) states that:

A rich performance measurement framework does not mean just picking a few non-financial measures to stand alongside the financial measures. Measures not only reflect strategy, they are also used for process control, so naturally they must be based on an analysis of the company's processes, as well as an understanding of how these processes are supported by knowledge and relationships.

However, it should be noted that determining and developing a comprehensive framework of performance measurements is always frustrating for managers, and the integration between measurements is often problematic particularly in including all the performance dimensions (Eccles, 1991). Also there are no standards for choosing performance measurements (Laitinen, 2002). Several performance measurement frameworks (e.g. SMART pyramid and the balanced scorecard) have been presented by various authors. These frameworks have been developed to sustain organisations in selecting the optimal financial and non-financial performance measurements.

2.9.1 The performance measurement matrix

This framework was introduced by Keegan et al. (1989) based upon the idea that performance measurements are a guide for management activities. Thus, the measurements should be derived from business strategy. This framework consists of four dimensions which are: internal, external, cost, and non-cost performance measurements. Some of the performance measurements used in this framework are shown in Figure 2.2. This framework is based upon the need and importance to support an organisation's multi-dimensional environment by the performance measurements. In addition, the performance measurements must be based on a thorough understanding of cost relationships and cost behaviour. This framework is easy to understand, and it consists of different performance measurement dimensions.

Figure 2.2 The performance measurement matrix. Source: Keegan et al. (1989), p. 48

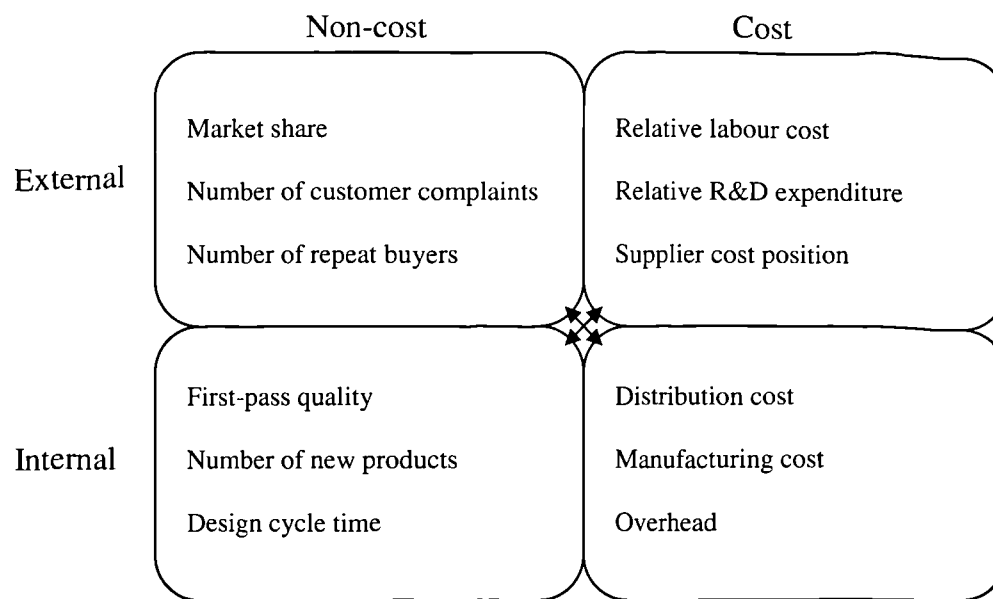

The strength of this framework lies in the way it seeks to integrate different classes of performance measurements (financial and non-financial, internal and external). The main weaknesses of this framework are that it does not provide specific criteria to choose the measurements, and it does not mention any dimensions relating to the innovation perspective and time. Finally, the framework also does not list any popular financial performance measurements such as return on investment.

2.9.2 The performance measurement questionnaire

In 1990, Dixon, Nanni and Vollmann developed the performance measurement questionnaire. This framework was developed to assess the fit between an organisation's performance measurement system and employees' perception of factors that are important to the success of organisation (McMann et al., 1994). The questionnaire relies on evaluating the effectiveness and efficiency of internal performance measurements and also ensuring consistency between the organisation's strategies and measurements. The questionnaire consists of four sections: the first section provides general data, section two evaluates organisation's competitive priorities and current performance measurement system. The third section is concerned with the indicators of performance measurements and the fourth section is for respondents to know the best measurements to evaluate their own performance. Table 2.3 provides a section from part two of the questionnaire.

Table 2.3 Section of part two of the performance measurement questionnaire. Source: McMann et al. (1994), p. 57

Long-run importance of improvement	Improvement areas	Effect of current performance on measures improvement
None >>>> Great		Inhibit >>>> Support
1 2 3 4 5 6 7	Quality	1 2 3 4 5 6 7
1 2 3 4 5 6 7	Labour Efficiency	1 2 3 4 5 6 7
1 2 3 4 5 6 7	Machine Efficiency	1 2 3 4 5 6 7
1 2 3 4 5 6 7	New Production Introduction	1 2 3 4 5 6 7

McMann et al. (1994) indicate that there are several types of analysis from questionnaire data, these are:

- Alignment analysis, which examines the congruence of organisation’s strategy, activities and measurements.
- Congruence analysis, which investigates how the current performance measurement system supports business strategy.
- Consensus analysis, which examines the data by management and functional level, this analysis provides information about the beliefs of employees.
- Confusion analysis, which provide information regarding the degree of variation in responses.

This framework provides information about the existing performance measurement system, and a feedback about areas that need enhancements in the current performance measurement system. The main disadvantage of this questionnaire is that it cannot be used as a comprehensive integrated performance measurement system and the failure to take into consideration the continuous improvement concept (Ghalayini and Noble, 1996).

2.9.3 The performance pyramid model

This framework was reported by Lynch and Cross (1995). It relies on a pyramid approach. This framework translates strategic objectives top down (based on customer priorities) and rolls measurements bottom up. The main objective of the pyramid is to contrive a management control system with performance measurements to achieve organisational objectives. The objectives of the pyramid consist of four levels. These are summarised as follows (see also Figure 2.3):

- The pyramid starts with the definition of business strategy, which is then translated into the business unit objectives.

- The second level of objectives consists of market and financial measurements; these measurements are identified to monitor performance and to achieve business strategy.
- The third level consists of the objectives and priorities for each operating system in terms of customer satisfaction.
- The fourth level consists of measurements related to individual departments.

Figure 2.3 The performance pyramid. Source: Lynch and Cross (1995), p. 65

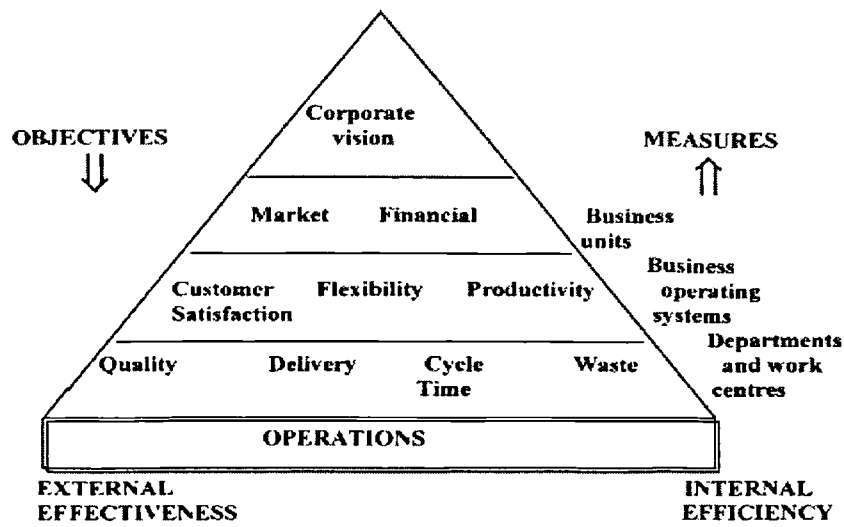

Lynch and Cross (1995) indicate that the pyramid is useful for describing the communication between organisational objectives. It is also useful for monitoring performance at all levels of organisation to ensure that the business strategy is satisfactorily implemented. This framework ties together the hierarchical view of business performance measurement with the business process view. It also differentiates between performance measurements that are of interest to external parties (customer satisfaction, quality and delivery) and performance measurements that are of interest within the business (productivity, cycle time and waste). The disadvantage of the pyramid is that it does not integrate the continuous improvement concept (Ghalayini and Noble, 1996).

2.9.4 The performance measurement system for the service industry

Fitzgerald et al. (1991) developed a performance measurement system for service industry purposes. This framework consists of several performance dimensions which are competitive performance, financial performance, quality of service, flexibility, resource utilisation, and innovation. These dimensions incorporate both financial and non-financial performance

measurements that are important to competitive success in addition to its main focus on several quantifiable aspects such as productivity and cost. The main feature of this framework is that all the dimensions fall into two main groups, they are:

- Results: This group consists of competitive and financial performance, which reflects the success of chosen strategy.
- Determinants: This group consists of quality of service, flexibility, resource utilisation, and innovation, which are the factors that determine competitive and financial performance.

Table 2.4 illustrates the dimensions and measurements of this framework. The results in the framework are a function of past business performance (lagging indicators), whereas the determinants are leading indicators. Fitzgerald et al. (1991) found that many service organisations have used the same criteria based on their suggested results and determinants categories. The main disadvantage of this performance framework is that the authors of this framework did not emphasise the causal link between the results and determinants.

Table 2.4 Performance measurement system for service industries. Source: Fitzgerald et al. (1991), p. 8

	Dimensions of Performance	Types of Measure	
Results	Competitiveness	Relative market share and position Sales growth Measures of customer base	
	Financial performance	Profitability Liquidity Capital structure	
Determinants	Quality of service	Reliability Responsiveness Aesthetics/appearance Cleanliness/tidiness Comfort Friendliness Communication Courtesy Competence Access Availability Security	
		Flexibility	Volume flexibility Delivery speed flexibility Specification flexibility
		Resource utilisation	Productivity Efficiency
		Innovation	Performance of the innovation process Performance of individual innovations

2.9.5 The EFQM business excellence model

The EFQM business excellence model has been developed by the European Foundation for Quality Management to assess organisational quality performance. EFQM has clearly become the most applied model in Europe for total quality management (Westlund, 2001). Oakland (1999) indicates that this model emphasises the society results dimension as one result of the quality development. The EFQM model shown in Figure 2.4 illustrates key business areas, (i.e. enablers and results), which are typically addressed by organisations to achieve superior business performance.

Figure 2.4 The EFQM model. Source: Westlund (2001), p. 127

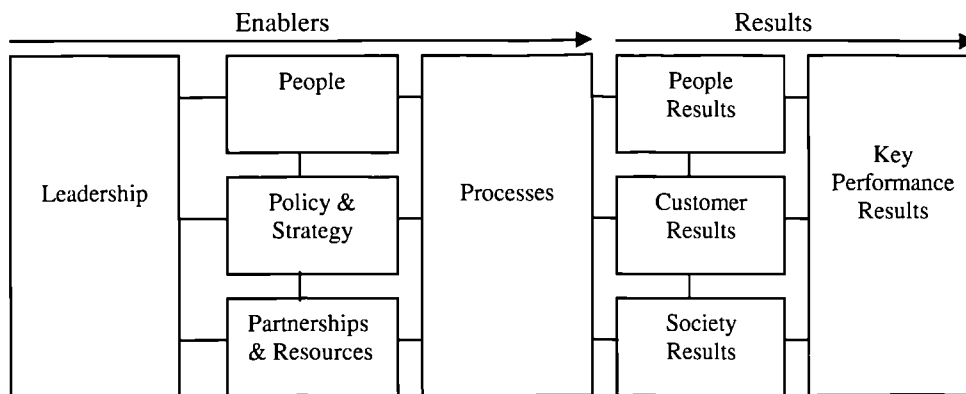

This model includes nine main categories such as customer satisfaction, people satisfaction and impact on society achieved through leadership driving policy and strategy, people management, resources and processes. Success in these categories leads ultimately to excellence in business results both financial measurements (e.g. profit and cash flow) and non-financial measurements such as market share and product delivery time (Hughes and Halsall, 2002). Oakland (1999) indicated that there are a large number of organisations using this model for self-assessment and in the entries for quality awards. Finally, it should be noted that this model contains no detailed instructions for its use, although the nine elements must be considered in the award assessment process (Wongrassamee et al., 2003).

2.9.6 The performance prism

This recent framework was developed by Neely et al. (2002). It is a comprehensive measurement framework that addresses the key business issues to companies (Neely et al., 2001). The performance prism has five perspectives, the top and bottom perspectives are the stakeholder satisfaction and stakeholder contribution. The remaining perspectives are strategies, processes and capabilities (Neely and Adams, 2001). In the first perspective,

managers should ascertain the needs and wants of the most influential stakeholders. After determining the stakeholders, it is necessary to choose the appropriate strategies that organisation should adopt to satisfy stakeholders needs. The performance measurements are then established after identifying the strategies. The third and fourth perspectives are to determine what processes need to be put in place to execute strategies. This is followed by determining the capabilities required for operating these processes. The final perspective is to identify stakeholder contribution to maintain and develop the capabilities. The advantage of this framework is the ability to allow the larger groups of stakeholders to be handled in the performance measurement scheme (Abran and Buglione, 2003).

2.9.7 The tableaux de bord

This performance measurement system emerged in France and was developed by process engineers who were looking for ways to enhance their production process by understanding the cause-effect relationships between actions and process performance. The same principle was then applied at the top management level to provide managers with a set of indicators to monitor the progress of organisation. The word tableaux de bord literally means ‘dashboard’ and it represents a set of indicators that allows managers or engineers to operate successfully. It can be used within organisations without depending just on financial performance measurements, because it also uses operational measurements (Lebas, 1994). According to Epstein and Manzoni (1998), the development of this framework involves translating a unit’s vision into a set of objectives from which the units identify their key success factors and translate them into quantitative key performance measurements.

The benefit of this framework is to provide managers with a periodic overview about a unit’s performance and the organisation overall, so that the tableaux de bord can contribute to the managerial decisions. This framework aims to provide management with vital information (Lebas, 1994). In conclusion, the tableaux de bord is a French tradition of management accounting. This tradition does not give the accounting-based information a major concern. Epstein and Manzoni (1997) indicate that this approach has not been widely adopted in practice due to the little emphasis that has been given to non-financial indicators.

2.9.8 The balanced scorecard

The best known and most cited performance measurement framework which incorporates key non-financial and financial performance measurements is the balanced scorecard (Ittner and Larcker, 1998a; Chenhall and Langfield-Smith, 1998a). This framework was originally devised by Kaplan and Norton (1992) to overcome the limitations of managing only with financial measurements, and was refined in their later publications to look at business strategy. This approach is an effective combination of financial and non-financial performance perspectives (i.e. customer, internal business processes/operational, learning and growth/innovation, and financial). The main benefit of implementing this approach is that it uses a set of financial and non-financial performance measurements, and these measurements are in line with business strategy.

Of particular interest to this approach was the number of models similar to that of Kaplan and Norton, and all of them were designed to measure business performance, and to link these measurements to the company's overall strategy (Olve et al., 1999). Noticeably, Maisel's balanced scorecard (1992) has the same name as Kaplan and Norton approach. Maisel (1992) defines four perspectives for performance measurements. Instead of a learning and growth perspective, Maisel uses a human-resource perspective in his model. Finally, the balanced scorecard has some limitations. For instance, Neely et al. (1995) indicated that the balanced scorecard does not consider the competitor perspective. Galayini and Noble (1996) argue that this technique is not intended to be applicable for all organisation levels.

2.10 Strategic performance measurement systems

Several researchers (e.g. Nanni et al., 1992; Lynch and Cross, 1995) have argued that an organisation's actions should be taken to support strategy, and the role of performance measurements is to support both actions and strategies (see Figure 2.5). However, performance measurements have to provide a strategic orientation to guide appropriate actions. Therefore, the strategy, the actions and the measurements must continuously match together (McAdam and Bailie, 2002). Recently, Cauvin and Bescos (2002) argued that performance measurements must evolve along with the organisation's objectives. When strategic objectives are achieved, new ones should be set requiring new actions then and also new performance measurements must be determined in order to control and co-ordinate organisation's strategy.

Figure 2.5 Links between performance measures, strategy and actions. Source: Nanni et al. (1992), p. 8

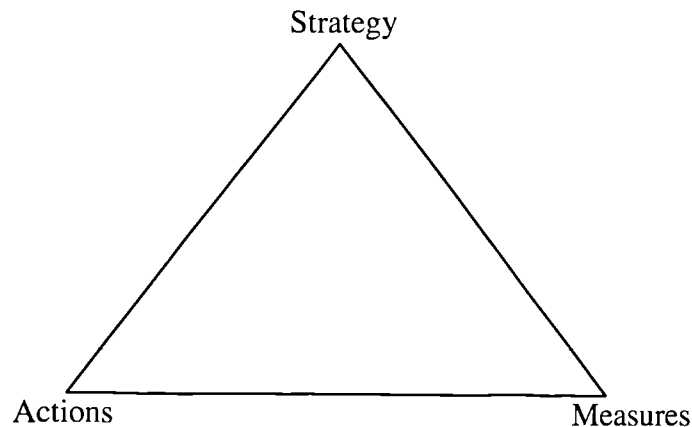

Recently, interest has been given to the role of strategic performance measurement systems in management accounting research. A study by the Conference Board defines strategic performance measurement (SPM) as a system that translates business strategies into deliverable results (Ittner, Larcker and Randall 2003, p. 717). A distinctive feature of strategic performance measurement systems is that they are designed to present managers with financial and non-financial measurements covering different perspectives which in combination, provide a way of translating strategy into a coherent set of performance measurements (Chenhall, 2005). Companies are adopting strategic performance measurements that: (1) provide information to identify the strategies for achieving the company's objectives, (2) align management processes, such as target setting, decision-making and performance evaluation, with the achievement of the chosen strategic objectives (Ittner, Larcker and Randall, 2003).

The proponents of strategic performance measurement (SPM) classify two approaches for developing strategic performance measurement systems. The first approach calls for using a diverse set of financial and non-financial measurements, and the second is based on contingency theory, which argues that SPM should be aligned with the firm's strategy and/or value drivers (Langfield-Smith, 1997). Closely related to the second approach is the use of performance measurement frameworks such as the balanced scorecard approach (Ittner, Larcker and Randall, 2003). In this context, Ittner, Larcker and Randall (2003) examined the relationship between measurement system satisfaction, economic performance and the two approaches to strategic performance measurement. The findings of the study showed that firms making more use of financial and non-financial measurements (i.e. first approach of

SPM) have higher measurement satisfaction and stock market returns than firms with similar strategies or value drivers (i.e. second approach of SPM). According to Chenhall (2005), there is a wide variation in the nature of SPM, ranging from combinations of financial and non-financial measurements to more comprehensive systems linking operations to various perspectives and to strategy. In this context, he conducted a survey of 80 strategic business units to examine the direct influence of integrative SPM on competitive strategic outcomes, and the indirect influence through the alignment of manufacturing with strategy and organisational learning. The findings of the study showed that SPM can enhance strategic competitiveness for organisations emphasising both differentiation and low cost strategies. The study also showed that SPM has the potential to improve the strategic competitiveness of organisations if they concentrate on connecting goals, strategies and operations. Finally, the study provided insights into how SPM enables organisations to achieve effective strategies by assisting in the strategic alignment of manufacturing and organisational learning.

2.11 New financial performance measurements

The increasing criticisms that have been made against financial performance measurements have resulted in organisations refining their financial performance measurements by incorporating economic value measurements such as cash flow return on investment and economic value added. The following sub-sections present a brief discussion of these measurements.

2.11.1 Economic value added

Economic value added (EVA) is a new measure of performance that was developed by the Stern Stewart Corporation as a re-assertion of more traditional accounting values, and to encourage managers to undertake only projects that will increase shareholder wealth (Ittner and Larcker, 1998a). This measurement was designed to align managers and shareholders' objectives. It is expected that organisations facing potential agency problems are more likely to implement this technique (Lovata and Costigan, 2002). EVA is defined as adjusted operating income minus a capital charge. This measurement assumes that manager's decisions only add economic value when the resulting profit exceeds the cost of capital.

The basic principle of EVA is that managers should be rewarded for considering projects that return more than the cost of capital. EVA also extends the traditional residual income

through incorporating adjustments to the financial performance measurements (Bromwich and Walker, 1998). Stern and Stewart have developed 160 accounting adjustment in order to convert the conventional accounting profit into EVA. These adjustments are intended to reflect the economic consequences better than the traditional performance measurements. Stewart argues that this measurement of performance is superior to other financial metrics, because it requires managers to place greater emphasis on long-term planning, and on increasing shareholders value. The EVA measurement is also claimed to be less problematic in respect of dysfunctional decision-making for managers (Otley, 1999). According to Kaplan and Norton (2001c), EVA addresses the defect in the ROI and pure accounting income calculations that ignore the cost of assets employed to generate accounting profits. Several studies have described EVA and its effect on market returns and managerial implications, and these studies provide conflicting evidence to the contribution of EVA (Ittner and Larcker, 1998a; Lovata and Costigan, 2002). Researchers have criticised the EVA technique for the following reasons:

1. It does not pay explicit attention to business strategy (Otley, 2001).
2. The calculation of EVA is complex (Ittner and Larcker, 1998a).
3. Its high implementation cost and the need for additional training for the new metrics (Lovata and Costigan, 2002).
4. EVA has been criticised by accounting academics for not being a new concept, having little difference from traditional financial measurements such as residual income and cash flow (Yeniyurt, 2003).

Ittner and Larcker (2001) also conclude that there is no clear evidence about the EVA being a preferable technique for management planning and control purposes. Like all financial measurements, EVA is subject to limitations. However, EVA can be used within the framework of the balanced scorecard to ensure that its financial portion provides appropriate measurements (Olive et al., 1999). Therefore, EVA has emerged as a major performance measurement within the financial perspective of the balanced scorecard (Otley, 2001).

2.11.2 Cash flow return on investment

Cash flow return on investment (CFROI) is another new measurement of performance that has been advocated by consulting firms. Advocates of CFROI argue that this measurement is vastly superior to traditional accounting performance measurements (Ittner and Larcker,

1998a). CFROI is defined as long-term internal rate of return, calculated by dividing inflation-adjusted cash flow by the inflation-adjusted cash investment. Bierman (1988) indicated that using this approach will overcome the limitations of financial performance measurements particularly the traditional cash flow.

2.12 The choice of strategic performance measurement system

Sections 2.9 and 2.10 have reviewed the most popular performance measurement frameworks, their basic assumptions and the strategic performance measurement systems. These performance frameworks have gained increasing importance in different countries based upon the usage of financial and non-financial performance measurements (Guenther and Gruening, 2002). Thus, it can be argued that using key non-financial performance measurements and integrating financial and non-financial measurements is one of the challenges that face organisations. As a result, many companies are supplementing financial measurements with a diverse set of non-financial measures that are believed to provide better information on strategic success (Ittner, Larcker and Randall, 2003). Each framework claims to be comprehensive and unique, but they all coexist because they all add value (Neely and Adams, 2001). Thus, it can be argued that there is no standard performance measurement framework for organisations to choose, and the authors who have presented these frameworks have recommended organisations to use these frameworks instead of using a single measurement. In the same context, Neely et al. (2000) argued that little attention has been devoted to the how these proposed performance measurement frameworks could be populated, and which framework can be adopted by organisations. However, it should be noted that there has been little research concerning the success and failure of the implementation of performance measurement frameworks (Bourne et al., 2002). Of these generic frameworks, the balanced scorecard has the largest market penetration, and tackles performance at the organisational level, business unit level, and the individual level (Abran and Buglione, 2003). In this context, Neely et al. (2001, p. 6) state that:

The balanced scorecard has been used and often abused-across the world, whereas many other frameworks have tended only to have regional appeal.

The balanced scorecard represents a major development by focusing on an effective combination of financial and non-financial measurements to provide a reliable feedback for management control purposes and performance evaluation (Kaplan and Norton, 1992; Ittner

and Larcker, 1998a; Hoque and James, 2000; Malina and Selto, 2001; Lillis, 2002; Rouse et al., 2002; Giannetti et al., 2002; Guenther and Gruening, 2002). According to Chow et al. (1997), a recent survey has found that 80% of large American companies want to change their performance measurement systems, and the balanced scorecard may be just what companies need to meet the demand of 21st century. In their book, Olve et al. (1999) stress that there are a large number of companies who have used the balanced scorecard approach, furthermore, they indicate that many companies have developed their own design and name for this approach.

In response to the perceived importance of strategic performance measurement systems, this research investigates the extent of usage of a diverse set of financial and non-financial performance measurements as the first approach for strategic performance measurement systems and the balanced scorecard approach as the second approach. However, a contingency approach to performance measurement has been widely used in management accounting research (Larcker, 1981; Gordon and Narayanan, 1984; Simons, 1987; Sim and Killough, 1998). In addition, Ittner and Larcker (2001, p. 373) argue that non-financial value driver studies also ignore contingent factors, even though it is likely that issues such as strategy, competitive environment, and customer requirements moderate the relation between these drivers and economic performance. Therefore, the research also considers the influence of several contingent variables on the extent of usage of a diverse set of financial and non-financial performance measurements.

2.13 Summary

This chapter has presented a review of the literature on performance measurement systems. The general overview shows that performance measurement system is considered to present an important part of the management accounting information system. On the one hand, there is a general agreement about the inadequacy of relying solely on the financial performance measurements. On the other hand, it has been made quite clear that there is a need to consider non-financial performance measurements. However, there is enthusiasm for combining both financial and non-financial performance measurements. It is considered that the combination of measurements can help to overcome the perceived limitations of the traditional financial performance measurements. Moreover, non-financial measurements can cope with the new

changes and developments that face organisations in terms of increased competition, new manufacturing practices and continuous improvement.

In the United Kingdom, empirical studies (e.g. CIMA, 1993; Drury et al., 1993) have shown that financial measurements still maintain a strong position, although non-financial performance measurements have been gaining interest. Moreover, the new models of control, which include non-financial measurements, are becoming widely accepted at British companies (Bromwich and Bhimani, 1994). The new developments in performance measurements have revolved around the integration between financial and non-financial performance measurements.

This Chapter has described the current integrative frameworks that have been suggested by different authors (e.g. Keegan et al., 1989; Fitzgerald et al., 1991; Kaplan and Norton, 1992; McMann et al., 1994; Lynch and Cross, 1995) and the strategic performance measurement systems. According to the literature review, these frameworks have benefits and limitations. Therefore, organisations have the choice to implement the most suitable framework that copes with its objectives. In recent years, management accountants and academics have shown a great deal of interest for the balanced scorecard. Thus, this research attempts to pay attention to the previous discussion to integrate financial and non-financial performance measurements and their implications, and the usage of balanced scorecard approach in the UK manufacturing companies. The balanced scorecard and its emergence and main assumptions are the focus of the next chapter. The purpose is to provide an understanding of the assumptions, strength and weaknesses of the balanced scorecard approach.

Chapter 3

The balanced scorecard approach

3.1	Introduction.....	3-2
3.2	The emergence of the balanced scorecard approach.....	3-3
3.3	Strategic management system assumption.....	3-7
3.4	The cause-and-effect assumption.....	3-10
3.5	Balanced scorecard relevant literature review.....	3-11
3.6	Evaluating the balanced scorecard approach.....	3-24
	3.6.1 The popularity of the balanced scorecard.....	3-24
	3.6.2 The balanced scorecard as a strategic management tool.....	3-27
	3.6.3 The balanced scorecard as a cause-and-effect model.....	3-28
	3.6.4 The number of balanced scorecard perspectives and measures.....	3-29
	3.6.5 Balanced scorecard models.....	3-31
	3.6.6 Balanced scorecard and compensation plans.....	3-32
3.7	Benefits and limitations of the balanced scorecard approach.....	3-33
3.8	An overview of the balanced scorecard approach.....	3-35
3.9	Summary.....	3-36

Chapter 3

The balanced scorecard approach

3.1 Introduction

Chapter two has demonstrated the importance of integrating financial and non-financial performance measurements. It was also pointed out that this research will adopt the balanced scorecard approach (BSC) for combining financial and non-financial performance measures for ensuring an effective approach to management control (Hoque and James, 2000). Kaplan and Norton (1992; 1993; 1996a; 1996b) assert that the BSC approach provides an integrated set of financial and non-financial performance measures. These measures allow managers to examine their organisations from different perspectives. It includes both financial measures that report the results of past actions, and operational measures such as customer satisfaction, internal processes and innovation, which act as indicators for future financial performance.

In recent years, the BSC has attracted considerable interest in practice as well as theory. A great deal of literature has been published on the BSC approach and several surveys indicate that this approach is widely used in companies in the United States and throughout Europe. However, the BSC lends itself to various interpretations because it can be and is used in different ways (Braam and Nijssen, 2004b; Ax and Bjornenak, 2005). Finally, many issues relating to the assumptions of the BSC have been raised by several researchers.

This chapter aims to discuss the assumptions of the balanced scorecard approach and to review the related literature. Section 3.2 starts with the emergence of the approach. Sections 3.3 and 3.4 continue with the main assumptions of this approach. Section 3.5 reviews the balanced scorecard theoretical and empirical research. This is followed by section 3.6, which evaluates the balanced scorecard approach and its assumptions. Section 3.7 summarises the benefits and limitations of this approach. An overview of the balanced scorecard approach is presented in section 3.8. Finally, section 3.9 provides a summary and some concluding remarks.

3.2 The emergence of the balanced scorecard approach

In response to the need to incorporate key non-financial performance measures and integrate financial and non-financial measures, Kaplan and Norton (1992) devised the BSC as a set of performance measures to provide managers with a comprehensive view of the organisation, and a reliable feedback for management control purposes and performance evaluation. This approach consists of two types of performance measures. The first is financial measures to describe the past actions. The second is non-financial measures on customer satisfaction, internal business processes, and innovation and improvement activities as drivers of future financial performance. Kaplan and Norton (1996c) indicated that the measures of this approach represent a balance between external measures for shareholders and customers, and internal measures for critical business processes, innovation and learning and growth. These measures are balanced between the outcome measures (i.e. the results from past efforts) and the measures that drive future performance. In their writings, Kaplan and Norton (1992; 1993; 1996a; 1996b; 1996c; 1997; 2000; 2001a; 2001b; 2001c) stressed that the BSC aims to provide answers to the following questions:

1. How do customers see us? (Customer perspective).
2. What must we excel at? (Internal business process/operational perspective).
3. Can we continue to improve and create value? (Learning & growth/innovation perspective).
4. How we look to shareholders? (Financial perspective).

According to Kaplan and Norton (1992), the BSC approach consists of the following performance perspectives¹ (see Figure 3.1):

- **Customer perspective:** The measures relating to this perspective require managers to translate their general mission statement on customer and market segments into specific measures that reflect the factors that really matter to the customers. Managers should develop performance measures in order to create satisfied and loyal customers in the targeted segments. Customer's concerns relate to time, quality, service and cost. Therefore, the customer perspective includes different core objectives and measures that relate to the organisation's strategy. Examples include goals and measures relating to increasing market share, customer retention, and customer satisfaction.

¹ Internal business process perspective is described in the balanced scorecard literature by operational perspective, and learning and growth perspective is also described by innovation perspective thus, these terms will be used interchangeably in this chapter and throughout the study.

- Internal business process/operational perspective: The measures within this perspective are related to the critical internal processes for which the organisation must excel to implement strategy. The identified processes should stem from the requirements needed to achieve the organisation's customer perspective. Kaplan and Norton identified several generic internal processes, such as operation and post-service sales processes, and stress the need to develop appropriate performance measures relating to these processes such as measures related to time, quality and cost.
- Learning and growth/innovation perspective: These types of measures are concerned with building continuous improvement in relation to products and processes, and to also create long-term growth. Kaplan and Norton stress that organisations can improve and innovate to achieve the objectives of the scorecard through the ability to launch new products, improve operating efficiencies and create more value for customers.
- Financial perspective: Measures within this perspective are based on financial metrics such as return on investment, and residual income. Kaplan and Norton argued that by incorporating non-financial performance measures in the scorecard, improved financial measures should follow. Moreover, this perspective provides feedback as to whether improved performance in the non-financial perspectives is translated into monetary terms in the financial perspective box.

Figure 3.1 The balanced scorecard. Source: Kaplan and Norton (1996c), p. 76

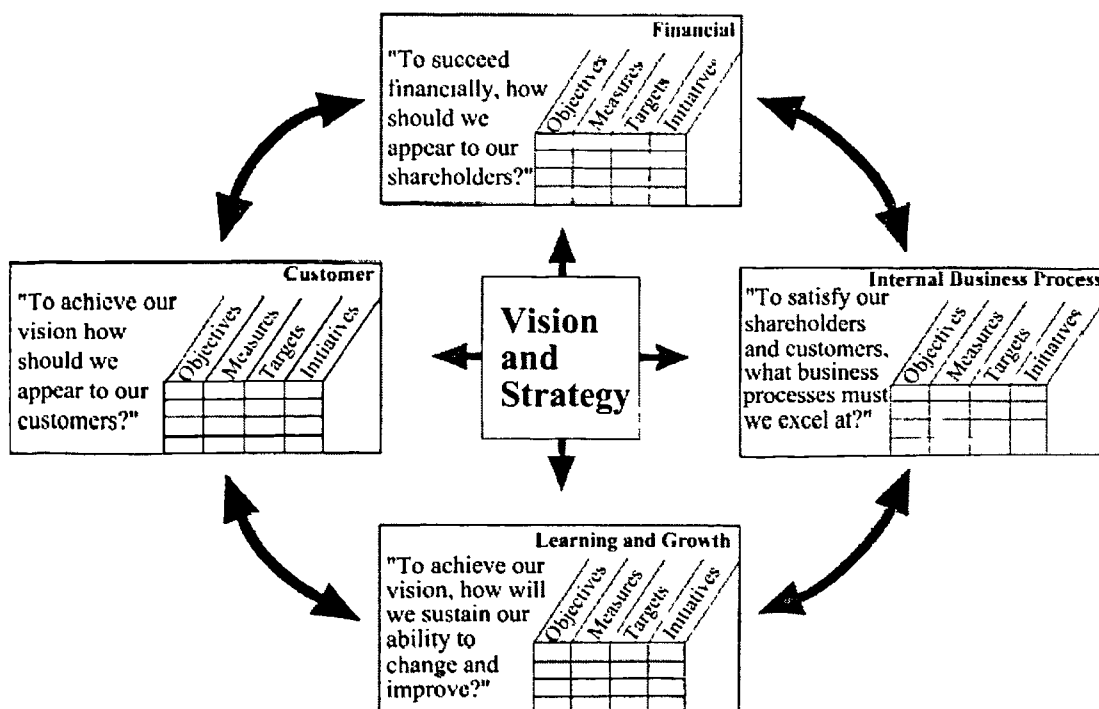

Figure 3.1 illustrates each of the perspectives, in which managers identify aspects which affect performance. For each aspect, they identify objectives, measures, targets and then they identify initiatives to create improvements. Thus, organisations should articulate the major goals for each of the four perspectives, and then translate these goals into specific performance measures (Kaplan and Norton, 1992). This can be achieved by putting the scorecard in the middle in order to evaluate strategy in the light of performance measures. In this context, Kaplan and Norton (1992, p. 73) state that:

The scorecard brings together in a single report many of the disparate elements of the company's competitive agenda, e.g. becoming customer oriented, shortening response time, improving quality, emphasizing team-work, reducing new product launch times and managing for the long term.

The main characteristics of the BSC approach according to Kaplan and Norton (1996a) are:

- This approach is connected to the organisation's information system.
- It reports a series of indicators providing a complete view of the organisation's performance.
- It groups the indicators into four perspectives; each one reflects a distinct measure on the organisation's performance.
- The performance measures in the scorecard must be chosen on the basis of their link with vision and strategy of the organisation.

Based on the aforementioned characteristics, the BSC approach consists of the following levels of information:

- The first level describes corporate objectives, measures and targets.
- The second level translates corporate targets into business unit's targets.
- In the third level, organisations ask teams and individuals to articulate which of their own objectives would be consistent with organisational objectives, and what are the initiatives they would take to achieve their objectives.

The BSC can be applied in different businesses under several situations. Examples include different competitive environments and market situations. According to the experiences of Kaplan and Norton (1996c), however, the BSC is most successful when it used to drive the process of change. In their publications, Kaplan and Norton argued that the scorecard process works best in strategic business units, although some organisations have applied this

approach on a single organisational level. Kaplan and Norton (2001b) also argue that this approach is applicable in manufacturing organisations as well as non-profit and government organisations. Kaplan and Norton (1992; 1993) noted that many organisations combined operational and financial performance measures for their activities, and these measures are bottom-up and derived from ad hoc processes. They argue that the appropriate set of scorecard's measures should be derived from organisation's strategic objectives. In this context, they recommended several steps to help managers to design a balanced performance measurement system. These steps are presented in Table 3.1.

Table 3.1 Designing a balanced scorecard. Source: Kaplan and Norton (1993), p. 138-139

Designing a balanced scorecard	
1.	Preparation: Identify the business unit for which a top-level balanced scorecard is appropriate.
2.	Interviews-first round: Process facilitator interviews all the firm's senior managers and asks them to identify the company's strategic objectives and possible performance measures for the scorecard.
3.	Executive workshop-first round: Senior management group debate the proposed mission and strategy statements until they reach a consensus. The process facilitator then asks the senior managers to answer the following questions: "If I succeed with my vision and strategy, how will my performance differ for shareholders; for customers; for internal business processes; for my ability to innovate, grow and improve?"
4.	Interviews-second round: Process facilitator summarises the output from the first executive workshop and discusses it with each senior manager. The facilitator also seeks opinions about issues involved in implementation.
5.	Executive workshop-second round: Larger workshop at which the senior managers and their direct reports debate the mission and strategy statements. "The participants, working in groups, comment on the proposed measures, link the various change programmes under way to the measures, and start to develop an implementation plan". Stretch targets are also formulated for each measure.
6.	Executive workshop-third round: "The senior executive team meets to come to a final consensus on the vision, objectives, and measurements developed in the two workshops; to develop stretch targets for each measure on the scorecard; and to identify preliminary action programmes to achieve the targets. The team must agree on an implementation programme, including communication of the scorecard to employees, integrating the scorecard into a management philosophy, and developing an information system to support the scorecard".
7.	Implementation: New implementation team formulates detailed implementation plan. This covers issues such as: how the measures can be linked to databases and information systems; how the scorecard can be communicated throughout the organisation; and how a second level set of metrics will be developed.
8.	Periodic reviews: Each quarter or month, a book of information on the balanced scorecard measures is prepared for both top management review and discussion with managers of decentralised divisions and departments. The balanced scorecard metrics are revisited annually as part of the strategic planning, goal setting, and resource allocation processes.

Moreover, Kaplan and Norton (1996a) identified a number of reasons to use the BSC approach:

1. Clarify and update strategy.
2. Communicate strategy throughout the organisation.
3. Align unit and individual goals with the strategy.
4. Link strategic objectives to long-term targets and budgets.
5. Identify strategic initiatives.
6. Conduct periodic performance review to improve strategy.

However, the BSC has several advantages over traditional management reporting. Some of these advantages include greater flexibility, evaluation of innovation and learning, and the ability to communicate key factors that drive performance (Kaplan and Norton, 1993). In addition, many of the dysfunctional consequences encouraged by traditional financial performance measures are avoided due to the broad range of performance indicators generated by using the BSC and its assumptions. Thus, it is appropriate at this stage to present the assumptions of the BSC approach.

3.3 Strategic management system assumption

Management accounting has developed measurement systems to reflect strategy. Therefore, performance measures are designed to help personnel keep track on whether they are moving in the chosen direction or not (Neely and Adams, 2001). The connection between performance measures, organisational objectives and strategy is very important and challenging (Nanni et al., 1992; Kloot and Martin, 2000). By implementing the BSC, organisations will move beyond the vision for the scorecard to discover its value as a cornerstone of a new strategic management system (Kaplan and Norton, 1996a). In this context, Kaplan and Norton (1996b, p. 85) state that:

The balanced scorecard provides a framework for managing the implementation of strategy while also allowing the strategy itself to evolve in response to changes in company's competitive market and technological environments.

Kaplan and Norton's experiences of innovative companies implementing the BSC indicated that they were using it, not only to clarify and communicate strategy, but also to manage strategy. They concluded that this approach has evolved from an improved performance measurement system to a core strategic management system. Recently, Kaplan and Norton

(2001c) argued that the early BSC adopters all used the scorecard to support major strategic and organisational change, and many organisations' management control systems are designed around the financial performance measures, which give little relation to the organisation's progress in achieving long-term strategic objectives. Therefore, they indicated that by implementing the BSC, organisations can introduce the following management processes that aim to link long-term strategic objectives with short-term activities (see Figure 3.2 for a summary of these processes and their linkages):

- Clarifying and translating the vision: This process helps managers in building a consensus around the organisation's vision and strategy. Developing a mission statement is a major responsibility of senior management team, and this statement must be expressed as an integrated set of goals and measures to managers in order to translate the vision to day-to-day actions.
- Communicating and linking: In this process managers have to communicate the strategy and link it to departmental and individual objectives and this process can be achieved by aligning employees with overall strategy. Communicating and linking strategy needs the following activities:
 - Communicating to and educating the employees who have to execute the strategy and this activity can inform managers that long-term strategies are in place.
 - Specifying the organisation's strategic objectives and measures must be translated into measures for the operating units and individuals.
 - Linking rewards to scorecard measures in order to play a major role in the determination of incentive compensation plans.
- Business planning: Many organisations are implementing change programs, and these changes will result in diversity with several initiatives, which might affect achieving goals. Therefore, the BSC set of goals and measures will help managers to undertake and co-ordinate only the initiatives that move the organisation towards the long-term strategic objectives.
- Feedback and learning: This process provides organisations with the feedback and review processes about whether the departments or employees have met their budgeted financial targets.

Kaplan and Norton (1996a) highlighted that the new management processes will separately and collectively contribute to the linkage between long-term strategic objectives and short-term actions. They also argued that the BSC approach is not primarily an evaluation method,

but a strategic planning and communication device to provide guidance to divisional managers and to describe links among lagging and leading measures of financial and non-financial performance. Kaplan and Norton (1996b) added that this approach is not just a strategic measurement system but also a strategic control system that may be used to:

- Clarify and gain general agreement about the strategy.
- Align divisional and personal objectives to strategy.
- Link strategic objectives to long-term targets and budgets.
- Identify and align strategic initiatives.
- Obtain feedback to learn about improve strategy.

Figure 3.2 Managing strategy. Source: Kaplan and Norton (1996a) p. 77

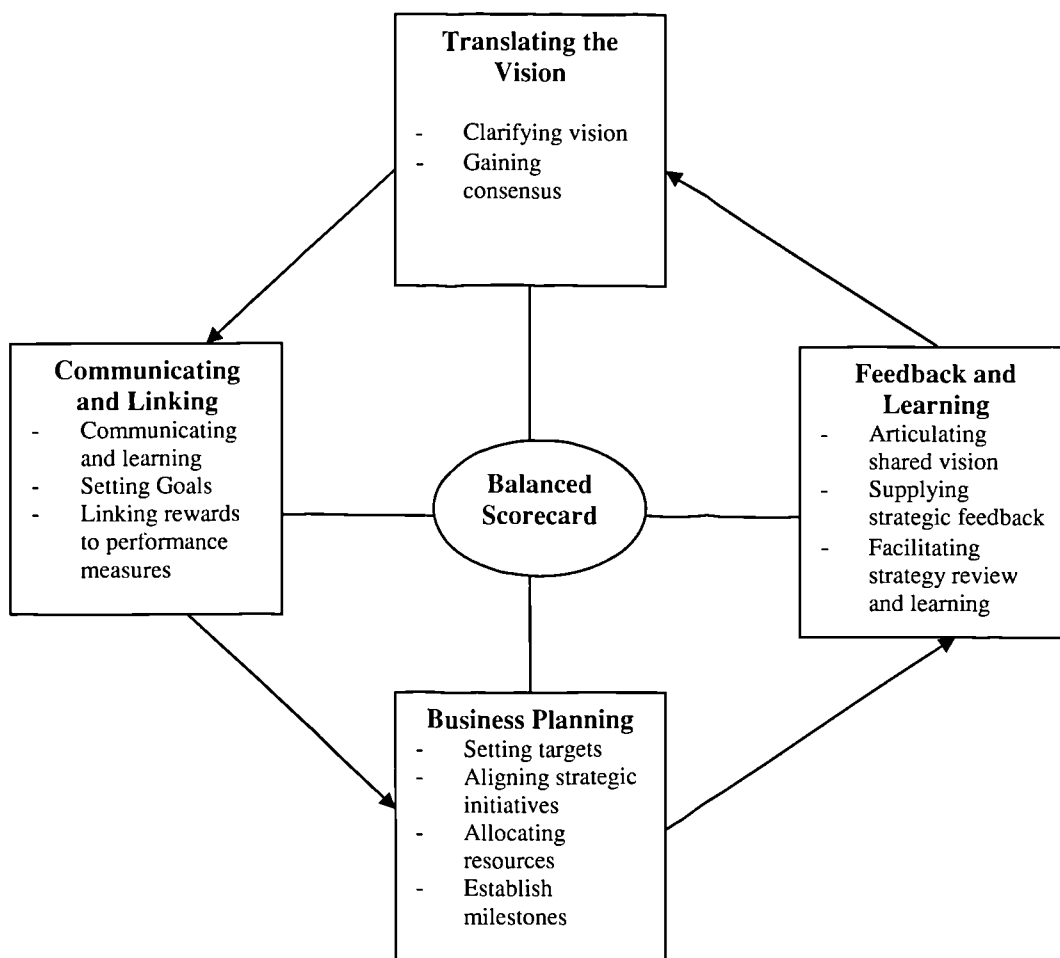

In the same vein, Amaratunga et al. (2001) argued that BSC approach is a strategic management system because it is efficient, effective and provides service to customers and employees. They also identified that a good BSC should tell the story of the organisational strategy by concentrating on the following criteria:

1. Cause-and-effect relationships.
2. Performance drivers which represent a mix of lead and lag indicators.
3. Linking organisational objectives to financial indicators.

Based on their argument that the BSC is considered a strategic management system, Kaplan and Norton (1996c) conducted a survey of management practices related to performance measurement and performance management systems at a conference in the United Kingdom. The survey was designed to explore how companies were currently managing the four components of a strategic management system. They received responses from more than one hundred managers supporting the idea that the BSC approach is a strategic management system. In the same context, Hepworth (1998) argued that a successful implementation of this approach is based on its ability to communicate and align business strategy between the four perspectives. In their recent book *'The Strategy Focused Organization'* Kaplan and Norton stress that the BSC differs from other performance measurement systems in the way it describes strategy. Thus, a properly constructed BSC should describe the business unit's strategy, and this strategy is a set of hypotheses about cause-and-effect chains (Kaplan and Norton, 1997).

3.4 The cause-and-effect assumption

In their later writings, Kaplan and Norton (1996a; 1996b; 1997) assume that the scorecard is based on cause-and-effect relationships, in which the measures of organisational learning and growth are the drivers of the internal business processes. The measures of these processes are in turn the drivers of measures of customer perspective, while these measures are the driver of the financial perspective. They assume the following causal relationship:

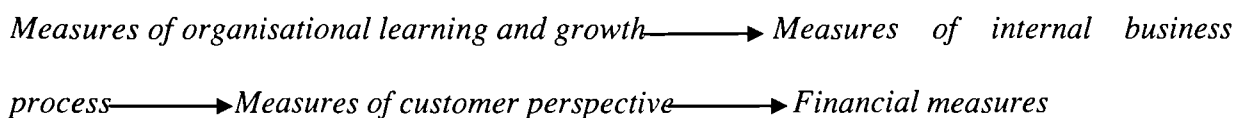

The assumption that there is a cause-and-effect relationship is necessary because it allows the measurements in non-financial perspectives to be used to predict future financial performance. Kaplan and Norton (1996b) indicate that the chain of cause-and-effect relationships encompasses all four perspectives of the BSC, such as return on common equity may be an outcome measure in the financial perspective. The driver of this measure could be

an expansion of sales from existing customers. So, customers' loyalty could be a preference from on-time delivery. Thus, the improved on-time delivery is expected to lead to higher customer loyalty which in turn leads to higher financial performance. The on-time delivery is part of the internal business process perspective and to achieve it, the business need to achieve short cycle time in operating processes and the short cycle time can be achieved by training the employees, and this goal is part of the learning and growth perspective. In order to clarify the cause-and-effect relationships, Kaplan and Norton (2000) introduced the strategic map concept. This concept provides a visual representation of a company's objectives, and the crucial relationships among them that drive organisational performance. Strategy maps show the cause-and-effect links by which specific improvements create desired outcomes. It also shows how an organisation will convert its initiatives and resources into tangible outcomes (Kaplan and Norton, 2001c).

The above description indicates that the BSC approach has evolved since its launch in 1992 as a new framework for measuring organisation performance. It was proposed to overcome the limitations of traditional performance measures. This approach was refined to show how it could move beyond a performance measurement system to become a framework for strategic management system. Having described the emergence and the assumptions of the BSC approach, the following section provides a relevant literature review of this approach in order to assess its importance to this study.

3.5 Balanced scorecard relevant literature review

The balanced scorecard (BSC) approach has attracted much attention by management accounting researchers as a method of integrating financial and non-financial performance measures (Lipe and Salterio, 2000; Malmi, 2001). Since its introduction in the early 1990s, the BSC has attracted a great deal of interest as a new management accounting technique. This is evidenced by the large number of publications in management journals, seminars, and workshops that have been devoted to it. Many researchers to date have focused on different aspects of the BSC, and this has provoked a considerable amount of argument and debate. Researchers have described the BSC as a broad scope mechanism of financial and non-financial information (Butler et al., 1997; Epstein and Manzoni, 1998; Mooraj et al., 1999; Otley, 1999; Laitinen, 2002; Braam et al., 2002). However, the focus of this section is on the most relevant theoretical and empirical studies that have investigated the BSC.

Chenhall and Langfield-Smith (1998a) conducted a survey to investigate the extent to which Australian manufacturing companies adopted both recently developed management accounting practices and traditional practices. The sample comprised of 78 strategic business units, divisions, and companies. The findings of the study which were related to performance measurements showed that there were high adoption rates for using traditional financial performance measures such as budgets and return on investment. However, the BSC approach was included in the medium ranking adoption category. The results of this study raised several issues that warrant future research, these issues were:

- The lower benefits associated with new management accounting techniques raises the question of the conditions necessary to implement these techniques.
- Examining the factors that influence the adoption of new management accounting techniques.

Based on 132 responses from the Institute of Management Accountant's Cost Management Group Members and Executives (USA), Frigo and Krumwiede (1999) carried out a survey to examine the implementation levels of BSC. The respondents comprised 55% manufacturing companies and 45% non-manufacturing companies. The findings of the study showed that 19% of the respondents reported that their companies are already BSC users and 18% of the respondents indicated that their companies have recently begun the implementation process. Although, 16% reported that their companies plan to use it in the future, 14% are still considering implementing the BSC, and only 2% reported rejecting or abandoning BSC. Frigo and Krumwiede (1999) also found that large companies in terms of both employees and annual sales are using this approach. BSC companies also appear to have higher quality information systems. The researchers also asked the respondents to rate the perspectives of their BSC. The financial perspective received the highest ratings, and customer, internal business processes and innovation showed lower ratings than the financial perspective. Likewise, employee, supplier, information systems capability and environmental perspectives were rated less than Kaplan and Norton's four perspectives. Finally, the researchers found weak linkages between the financial and non-financial perspectives for the non-BSC users whereas the BSC users reported considerably higher linkages between the perspectives.

Based on the assumptions lying behind the cause-and-effect of the perspectives of the BSC, Oliveras and Amat (2002) conducted an empirical survey on 254 companies in Spain, to investigate the validity of the following hypotheses:

- It was suggested that strong backing for training and incentives could contribute to a greater employee involvement.
- This greater employee involvement can favour greater cost and asset efficiency, support for total quality, greater innovation and a customer oriented approach. All of this should give rise to a continuous improvement in business processes.
- The improvement in business processes will lead to greater customer satisfaction, which ought to produce greater sales.
- Greater sales should result in greater profits and returns.

The results of the study showed that there was a possible cause-effect relation between the drivers of profitable company growth. The improvement in the internal business process perspective might have an impact on the satisfaction of customers, which would improve customer's loyalty towards a growth in sales. Thus, more committed employees can stimulate a constant improvement in the business internal processes. Finally, the findings of this study provide evidence regarding the possible cause-and-effect relationships between the BSC perspectives. However, they concluded that the BSC approach is a successful performance measurement system, and it is employed in different types of organisations in Spain including non-profit organisations.

Giannetti et al. (2002) conducted a survey to investigate the integration process of financial and non-financial performance measures, and the extent to which the Italian large and medium size companies use different approaches of performance measurement systems. The sample of the study consisted of 39 industrial companies from the same industry. The researchers' analysis was based on whether or not companies are using non-financial measures based on the BSC perspectives. Their analysis showed that the non-financial performance measures were generally used in management accounting systems in an integrated way with financial performance measures. However, only one company explicitly declared the implementation of the BSC approach, while the reminder of the sample used an approach which included all the perspectives of the BSC without declaring that they used this approach. Furthermore, the researchers explained their results by indicating that universities

and consulting firms did not introduce the BSC approach well in Italy, and the companies in the sample were well aware of this approach, but implementing the BSC may imply changes in their organisations.

Braam et al. (2002) carried out a study to explore the accumulation of ways in which the BSC approach was used in the Netherlands. The data were collected from the printing media traces associated with the BSC, interviews with management intellectuals, practitioners and the theoretical and empirical sources associated with the usage of the BSC approach. The study revealed that since its launch in 1992, the BSC has enjoyed considerable attention in the literature from practitioners and academics in the Netherlands. The study did not, however, support the notion of the actual use of this approach. Therefore, the researchers suggested the necessity to conduct more empirical studies to assess the usage of the BSC in Netherlands.

Guenther and Gruening (2002) conducted a cross-sectional study to investigate the performance measurement systems for 181 companies in Germany. The study looked at the use of performance measures and the development and establishment of these measures. Specifically, the researchers concentrated on how widely are performance measurement systems used and what kind of performance measurement frameworks the companies are implementing. Moreover, the study looked at the types of performance measures and their relationship with the strategy and the incentive schemes. As a result, the findings of Guenther and Gruening (2002) study revealed that the BSC was the dominating framework used in the sample, and most of the companies used a self-developed performance measurement system that modifies the original BSC approach. However, the performance measurement systems have to be adjusted to the strategy, and incentive plans based on performance measurement frameworks should incorporate both financial and non-financial measures.

Recently, Nielsen and Sorensen (2003) carried out a study to investigate the motives, diffusion and utilisation of the BSC approach in 53 Danish medium-sized and large manufacturing companies. The study aimed at investigating the extent to which the BSC practices were used following Kaplan and Norton's perspectives. The following are the main findings of the study:

- In comparison with other countries, Denmark was still in the initial phase of implementing this approach. The level of knowledge of the BSC was about 82%, whereas only 17% gave this approach the priority.
- The study confirmed that the most critical factor for a successful BSC was the translation of strategy to operational terms.
- The level of BSC usage was 32% among the sample.
- The use of non-financial measures should be in balance with financial measures. 80% of the sample confirmed the need for balanced performance measures.

In a comparison study between tableaux de bord and the BSC, Epstein and Manzoni (1998) indicated that the BSC is a better approach and that the tableaux de bord falls short because it places more emphasis on financial measures. In addition, most of the tableaux de bord measures are gathered internally inside the organisation rather than externally, and without collecting the measures from organisation's strategy. Further, managers are using the tableaux de bord as a device to support management rather than using it interactively. Finally, Epstein and Manzoni (1998) highlighted that organisations can expect to encounter difficulties in implementing the BSC approach, whereas, top management may not articulate a clear view of their strategy. Also, developing this approach can create a workload for many people in the organisation and this may lead to resistance against this workload. Furthermore, they suggested that organisations must pay more attention about linking the BSC to compensations. Finally, they emphasised that the BSC represents a good approach to both theory and practice.

In a recent comparison study between the American balanced scorecard and the French tableaux de bord based on literature studies, Bourguignon et al. (2004) investigated the ideological assumptions of the two approaches to explain the differences and the extent to which the ideological assumptions are consistent with the local ideologies of American and French society. The paper concluded that the main differences between the two approaches may be explained in terms of ideological assumptions, which means that the two approaches are consistent with the local ideologies in the countries of origin. In addition, Bourguignon et al. (2004) have reviewed the main similarities and differences between the two approaches. These are summarised in Table 3.2. The table shows the main differences between the two approaches relate to the strategic model, and the underlying assumptions applicable to each approach. In contrast, the similarities concentrated on the importance of both approaches to

the management of strategic decisions and the emphasis placed on using non-financial measures.

Table 3.2 Differences and similarities between the balanced scorecard and the tableaux de bord

	Balanced scorecard	Tableaux de bord
Differences	<ul style="list-style-type: none"> • Uses Michael Porter’s strategic model 	<ul style="list-style-type: none"> • Does not explicitly rely on specific strategic model
	<ul style="list-style-type: none"> • Assumes cause-and-effect relations between measures 	<ul style="list-style-type: none"> • Does not assume any systematic link between measures
	<ul style="list-style-type: none"> • A hierarchical top-down process from top management to lower levels 	<ul style="list-style-type: none"> • The deployment depends on the interaction and negotiation between the various levels
	<ul style="list-style-type: none"> • Encourages linking rewards to performance measures 	<ul style="list-style-type: none"> • Does has no emphasis on linking rewards to performance measures
	<ul style="list-style-type: none"> • A fashionable method without a tradition 	<ul style="list-style-type: none"> • Depends on a tradition for using, changing and developing concept
Similarities	<ul style="list-style-type: none"> • Both approaches link top management strategic decisions to the actions of employees • Both approaches use non-financial performance measurements for anticipation and control 	

Otley’s (1999) work has introduced a framework for the operation of management control system that focuses on the measurement of organisational performance. He also examined three major systems of organisational control (budgeting, economic value added, and balanced scorecard) from different perspectives (i.e. objectives, strategies, targets, rewards and feedback). The results of this study are summarised in Table 3.3.

Table 3.3 Comparison of the three control techniques. Source: Otley (1999), p. 378

Question	Budgetary control	EVA	Balanced scorecard
Objectives	Financial objectives: <ul style="list-style-type: none"> • Profit • Cash flow • ROCE 	Single financial objective	Multiple objectives based on strategy
Strategies & plans	Means/end relationships not formally considered although budget is based on a plan of action	Delegated to responsible managers, may be considered when setting targets	Implicit in selecting some performance measures; no formal procedures suggested
Targets	Best estimates for financial planning; literature on target-setting gives some guidelines for control	Some guidance is given with respect to inheritance effect	Not considered, despite being central to balance
Rewards	Not addressed, despite many rewards now being made contingent on budget achievement	Appropriate incentive schemes a central part of the methodology	Not addressed
Feedback	Short-term feedback of budget variances, incremental budgeting from year to year	Some discussion of longer-term impact	Reporting of performance assumed, but no explicit guidance given

Otley (1999) analysed the BSC approach in terms of the advantages and disadvantages. In summary, he concluded that this approach is a stakeholder approach and is enhanced by the incorporation of other perspectives. He also pointed out that little guidance is given in the

literature about the linkages between the four perspectives and the reward system and that further studies should contribute to this issue. In addition, more concentration should be given to setting targets in the BSC. Finally, Otley (1999) indicated that no single control technique has been developed to meet the five issues outlined in Table 3.3. Thus, the BSC is a dynamic and powerful technique to be used by organisations simultaneously with other control systems.

Based on the key sets of issues expressed by Otley (1999), recent research, however, conducted by Wongrassamee et al. (2003) has addressed the similarities and differences between the EFQM excellence model and the BSC. The analysis of both models based on five central areas of management control systems has shown that neither of them gives a clear answer to Otley's questions, but it does not mean that both models are insufficient. Further, both models are quite similar. The only difference between the two models is that the key objectives in the EFQM are assigned based on the principles of total quality management, whereas the key objectives in the BSC are based on business strategy (see Table 3.4).

Table 3.4 Comparison between the balanced scorecard and the EFQM. Source: Wongrassamee et al. (2003), p. 24

Question	Excellence model	Balanced scorecard
1) Objectives	Multiple objectives based on TQM principles, and emphasises nine areas: <ul style="list-style-type: none"> - Leadership - People management - Policy and strategy implementation - Resource management - Process management - People satisfaction - Customer satisfaction - Impact on society; and - Business results 	Multiple objectives based on strategy, and emphasise four generic areas: <ul style="list-style-type: none"> - Financial - Customer - Internal business processes; and - Innovation and learning
2) Strategies and plans	Not particularly addressed, but all weighted criteria and weighted sub-criteria can be used as guidance	Assign strategic measures. Uses strategy map to connect each measure to strategy
3) Targets	None specific. Management can set their expected performance levels	Not addressed. Due to non-perspective template, managers are required to assign target performance levels
4) Rewards	Requires an appropriate reward and recognition system, but no explicit guidance given	Suggests that individual compensation system should be linked to strategic measures
5) Feedback	Not mentioned. However, the model itself provides feedback information as a default of the assessment method	Requires double-loop learning which is more complicated than single-loop feedback

In a study to investigate the assumptions of the BSC, Norreklit (2000) examined the extent to which there is a cause-and-effect relationship among the four perspectives of the BSC. She also investigated whether the BSC can link strategy to performance metrics by analysing the assumptions and relationships of the BSC. The research used an analytical tool to answer the research questions and the theory of science to investigate the cause-and-effect relationships. Norreklit (2000) argued that the four perspectives are interdependent, and there is a time lag between cause-and-effect relationships, and the time dimension is not part of the scorecard. The analysis showed that the causality claimed between perspectives was problematic and made invalid assumptions, and there is not a causal but rather a logical relationship between the four perspectives. Moreover, the research investigated if the BSC approach is a strategic control tool. The analysis showed that this approach was not a valid strategic management tool because it has a problem of ensuring organisational and environmental issues are incorporated. Based on the findings of this study, Norreklit (2000) suggested several issues to reduce the problems of this approach, these are:

- Instead of causality, it may be useful to establish coherence between measures.
- Further theoretical consideration and advanced analysis about the relationships between the four perspectives.
- Coherence analysis to the level of strategy formulation is also needed.

Malmi (2001) conducted another noticeable piece of work about the assumptions of the BSC. He studied how the BSC approach was applied in Finland, and why companies adopted this approach, and whether this approach was used as an improved performance measurement system or as a strategic management system. For the purposes of the study, semi-structured interviews in 17 companies in Finland were employed. The study revealed that 15 companies used the four perspectives of the BSC and 2 companies added a fifth perspective which was an employee perspective. Noticeably, the interviews revealed that the measures used in companies were derived from business strategy. The number of measures in the BSC varied between four and twenty five among the sample interviewed. Within his paper, Malmi (2001) identified that there are several reasons for implementing this approach in Finland. These can be summarised as follows:

- Several companies used this approach to translate strategy into action.
- Quality programs required implementing this approach.

- To support innovation and changes.
- Several companies implemented this approach as a new management fashion.
- Inadequacies in traditional performance measures.

Malmi (2001) reported that this approach was applied in two different ways. Most organisations set targets for BSC measures and held managers accountable for achieving these measures. Other companies did not set targets for the measures, but used the scorecard as an information system. For most companies, it appears that BSC was developed independently of the budget process. More specifically, control by budgets has changed to control by BSC in two companies. Finally, the researcher suggested the following criteria to identify the usage of the BSC:

- 1) The measurement system should reflect strategy. This should not depend on how organisations define their strategies.
- 2) The measurement system should use the perspectives of the BSC irrespective of whether they are the original four or more or less.
- 3) The use of cause-effect relationships between the perspectives.

Despite the fact of the existence of an extensive literature review relating to the continuous debate of the theoretical framework to analyse the implementation and benefits of the BSC, Speckbacher et al. (2003) developed a new theoretical framework to analyse the spread, implementation and benefits of the following various types of balanced scorecards:

- Type one BSC's: a specific multidimensional framework for strategic performance measurement that combines financial and non-financial strategic measures.
- Type two BSC's: a type one BSC that additionally describes strategy by using cause-and-effect relationships.
- Type three BSCs: a type two BSC that also implements strategy by defining objectives, action plans, results and connecting incentives with BSC.

The researchers conducted a survey on 201 companies in the German-speaking countries (Germany, Austria, and Switzerland) to investigate the systematic application of the BSC. The results of the study based on 174 responding companies showed that 45 companies 26% have implemented the BSC. Half of them are type one BSC, 21% are type two and the

remaining 29% qualify as type three organisations. Moreover, 26% of the sample had a very preliminary BSC in use. In particular, a third of BSC users have no learning and growth perspective, and nearly one-fifth of the companies have established additional perspectives such as supplier and environment perspectives. Interestingly, more than two thirds of the users linked their reward system to the BSC, which suggests that many firms do not see cause-and-effect relationships as a prerequisite for a BSC-based reward system. Less than 7% of all firms have fully developed type three BSC's in use. Additionally, Speckbacher et al. (2003) found that 55% of the companies are implementing the BSC at the corporate level, 98% at the business unit level, 23% at the plant level, 23% at the department level, 10% at the team level and only 3% at the employee level. They also found that larger organisations are more likely to use the BSC, but organisation size did not discriminate between the types of BSC used. Finally, the analysis of the relationship between the types and the companies' perceived benefits and satisfaction showed that companies implementing a type three BSC were more satisfied with their BSC than those implementing type one or two of the BSC.

Malina and Selto (2001) conducted a case study in multiple divisions of a large international manufacturing company to investigate the effectiveness of the BSC as a strategy communication and management control device. Data were collected from BSC designers, administrators and managers employing semi-structured interviews. The findings of the study revealed that the BSC provide an opportunity to develop, communicate and implement strategy. They also found evidence of an indirect relationship between balanced scorecard's management control function and improved performance on balanced scorecard measures. Moreover, divisional managers responded positively to its measures by reorganising resources and activities. Managers in the sample believed in the BSC when:

- Its elements are measured effectively, aligned with strategy.
- It plays a major role in change.
- Its perspectives are linked causally.
- It provides a guide for modifications and improvements.

Furthermore, the researchers identified that there are different factors which may affect perceptions of the BSC that cause a conflict and tension between organisations and distributors. These factors are: (1) when measures are inaccurate or subjective, (2) when the BSC is not participative, and (3) when benchmarks are inappropriate but used for evaluation.

Lipe and Salterio (2000) conducted a study that attempted to understand the relationship between the BSC measures and management evaluation by examining the effect of the BSC as a set of common and unique indicators on top management evaluations of the unit's performance. Moreover, the BSC is costly to develop therefore, the researchers suggested that the benefits gained from adopting this approach depend on the extent to which it improves managers' decisions. They also examined how managers deal with both performance measures common to multiple divisions and unique performance measures for particular divisions. The sample of the study consisted of two divisions of a clothing company implementing the BSC. The divisions sold to different markets and had different business strategies. The results of the study suggest that common performance measures will have more effect on managers' decisions about division's performance than the unique performance measures. Consequently, the organisations will not expect benefits from adopting this approach.

Lipe and Salterio (2002) continued their stream of research, which they began in the year 2000. In this study they investigated whether evaluations using the BSC will differ from evaluations based upon the same measures without using the scorecard. The results revealed that when multiple performance measures within a BSC approach show consistent performance (e.g. above the target), managers' evaluation judgments are reliably different from evaluations made using the same performance measures without the BSC approach. These judgement differences disappeared when the measures indicating strong performance were distributed throughout the four perspectives of the BSC approach.

Drawing off the contingency literature, Hoque and James (2000) conducted one notable piece of work that focused on the relationship between BSC usage and organisation size, product life-cycle and strength of market share. The study also explored the contingent relationship between organisational performance and the match between BSC usage and the three contextual factors. A questionnaire survey of 66 Australian manufacturing companies was employed. The researchers did not identify the strategic linkages of the BSC. Instead they concentrated on company's tendency to use quantitative performance measures. The following are the hypotheses of the study:

- BSC usage is positively associated with large organisations, and companies with products at the growth stage, and companies with strong market position.

- The effect of BSC reliance on organisational performance will be more beneficial for large organisations than small organisations.
- The effect of BSC reliance on organisational performance will be more beneficial for organisations with products for the growth stage than the maturity stage.
- The effect of BSC reliance on organisational performance will be more beneficial for organisations with strong market position than weak market position.

The study concluded that there was a significant association between size and BSC. Another association was found between product life-cycle and the usage of the BSC, but there was no support for the association between strong market position and the BSC. Finally, BSC usage was associated with increased organisational performance, but this relationship did not depend on the fit between the three contextual factors.

Hoque et al. (2001) studied the relationship between several contextual factors (intensity of competition and computer-aided manufacturing and the use of multiple performance measures) in terms of the perspectives of the BSC. A questionnaire survey was employed to collect data from 71 manufacturing companies in New Zealand. The results of the study revealed that there was a positive and significant relationship between the intensity of market competition and the use of BSC perspectives. The results also revealed that there was a positive and significant relationship between the use of BSC perspectives and organisations that had implemented the computer-aided manufacturing process.

Recently, Dunk (2003) conducted cross-sectional research to investigate the extent to which the quality of the information system, corporate environmental integration, product innovation and product quality influence the financial and non-financial performance measures in terms of the BSC usage. A random sample of 119 functional managers from Australian manufacturing companies was extracted and a total of 77 functional managers responded. The results of the study suggested that the quality of information system, corporate environmental integration, product innovation and product quality influence the use of the perspectives of the BSC approach.

To explore the determinants of BSC adoption, Braam and Nijssen (2004a) conducted a mail survey of 38 industrial companies to study the contextual factors (i.e. size, top management involvement, centralisation, formalisation, power of financial department, interdepartmental

communications, innovation strategy, and prior adoption similar innovation) that might influence company's decision to adopt the BSC. The results showed that top management involvement, the power of the financial department, level of accounting tools and size were positively related with the level of adoption of the BSC. Furthermore, the results showed that the relationship between top management involvement and level of adoption were positively moderated by the level of centralisation, and the relationship between the power of financial department and the level of adoption is negatively moderated by formalisation. Conversely, innovation strategy, interdepartmental communication, centralisation and formalisation had no influence on the adoption of the BSC.

Braam and Nijssen (2004b) continued their stream of research on the BSC. In this study they investigated how Dutch companies are using the BSC effectively. The researchers suggested two models for measuring the usage of the BSC and then examined their effect on performance. The first model concentrated on the BSC as a performance measurement system and their effect on companies' performance. The second model was based on aligning business strategy to BSC performance measurement system. The findings of this study suggest that BSC use that is aligned to company strategy (i.e. the second model) positively influences overall company performance. On the other hand, the performance effect of BSC use (i.e. first model) is negative. Braam and Nijssen justified this result based on the idea that the BSC may be used in different ways involving different functional areas and indicators.

More recently, Banker et al. (2004) conducted a time series study on data from over fifty firms in the local exchange carrier industry to investigate the relationship and tradeoffs between four performance measures representing the perspectives of the BSC. The study was based on the following arguments: (1) if managerial actions to improve a performance measure do not imply a decline in financial performance, managers do not need to trade off one measure for the other. They refer to such measures as contemporaneously congruent, and (2) if a non-financial measure is contemporaneously congruent with the financial measure, then there is motivational distortion induced by a managerial reward system based on financial measures. However, if a measure is not contemporaneously congruent with financial performance, then it is crucial to include such a measure or the incentives induced by financial performance will lead to under-investment in effort to improve financial measures. The results showed that the two non-financial measures from the internal business process and innovation perspectives did not require any trade off with the ROA from the

financial perspective. Thus, a non-financial measure from the customer perspective required tradeoffs with ROA, and it was essential to include a percentage of this non-financial measure in addition to ROA in performance measurement and evaluation system to motivate managers.

A recent field study (longitudinal approach) on a banking organisation conducted by Davis and Albright (2004) investigated whether bank branches are implementing the BSC. The purpose of the study was to examine the effectiveness of the BSC in improving financial performance. The final number of branches after excluding several branches due to branch profile was nine. The results showed that four branches are implementing the BSC and the remaining five are non-BSC branches. The results provided evidence that branches implementing BSC have achieved improvements in financial performance when compared to non-BSC implementing branches.

3.6 Evaluating the balanced scorecard approach

Empirical studies on the balanced scorecard approach (BSC) have raised a number of issues that require a further discussion. These issues are divided into the following sub-sections:

- The popularity of the balanced scorecard.
- The balanced scorecard as a strategic management tool.
- The balanced scorecard as a cause-and-effect model.
- The number of balanced scorecard perspectives and measures.
- The balanced scorecard models.
- The balanced scorecard and compensations plans.

3.6.1 The popularity of the balanced scorecard

Many researchers (e.g. Chenhall and Langfield-Smith, 1998a; Otley, 1999; Norreklit, 2000; Ahn, 2001) agree that the BSC is a new development in management accounting, which has attracted considerable interest among companies and researchers through the increasing rate of adoption and through the large number of publications. In this vein, McCunn (1998, p. 36) argued that the BSC has academic respectability and has generated a large body of literature. In addition, Kaplan and Norton's textbook *'The Balanced Scorecard'* has been awarded a prize by the American Accounting Association for the best theoretical contribution

(Norreklit, 2003). Moreover, the frequency of papers citing Kaplan and Norton or the BSC has increased, and almost three-quarters of all papers² refer to the BSC concept (Marr and Schiuma, 2003).

Kaplan and Norton (2001a, p. 87) argue that the BSC is applicable in all types of organisations including non-profit organisations and the public sector. This argument has been supported by many researchers (e.g. Hepworth, 1998; Olve et al., 1999; Kloot and Martin, 2000; Johnsen, 2001; Oliveras and Amat, 2002). In this context, Radnor and Lovell (2003) outlined some grounds for supporting the usage of this approach in the local public sector in UK. They also asserted that the BSC approach offers significant benefits in terms of achieving government targets for enhanced transparency, clarity and accountability.

Attempting to address the increasing attention that has been given to BSC approach, several studies investigated the implementation of this approach. For example, a survey conducted in USA estimates that 60% of the fortune 1000 firms have experimented with the BSC (Silk, 1998). In the same vein, Littlewood (1999) presented evidence from Hackett Benchmarking Solutions (i.e. a US management consultancy) that 50% of 1,400 global businesses apply some kind of BSC (cited in Amaratunga et al., 2001). It has been predicted that by the year 2000, at least 40% of Fortune 1000 companies will have implemented the BSC (Balanced Scorecard Collaborative, 2000). This is consistent with evidence from the Institute of Management Accountants' Cost Management Group, which found that 40% of the surveyed firms reported that they plan to implement the BSC within the next two years (Frigo and Krumwiede, 2000).

Recent studies indicate that the BSC approach is on the move and has entered companies around Europe (Wenisch, 2003). In this context, Pere (1999) indicated that this approach is widely used in different companies in Finland. Of the respondents, 31% indicated that they have this system and 30% were implementing this approach. According to a study of major Swedish companies, 27% have already implemented the BSC (Kald and Nilsson, 2000). A recent comparative European study conducted by Gehrke and Horvath (2002) showed that companies in Germany, the United Kingdom, Italy and France are familiar with the BSC (i.e. 98%, 83%, 72% and 41% of the responding companies, respectively). Moreover, the study

² The most frequently cited journals are Harvard Business Review, International Journal of Operations & Production Management, Journal of Marketing, Journal of Management Accounting Research, and Strategic Management Journal.

revealed that approximately 20% of the companies in Germany, the United Kingdom and Italy aimed to implement the BSC. Dr. David Norton asserts that 50% of organisations in the UK and US use the balanced scorecard (Williams, 2001). Similarly, Francis and Minchington (2000) conducted a study to investigate the usage of value-based measures at the divisional level in UK organisations. One of the study findings showed the increasing popularity of the BSC with 24% usage rate in all sectors and a usage rate of 21% in the manufacturing sector. A new report by Business Intelligence showed that in the UK, 57% of the businesses are reported to use the BSC, and 56% of non-users are discussing implementing this approach (Anonymous, 2001). Recently, Bourne et al. (2002) examined the success and failure of using performance measurement systems in 10 manufacturing businesses. The results showed that 8 businesses implemented the BSC at the top level. In a similar vein, Lawson et al. (2003a) indicated that firms can implement the BSC at the corporate level first and then roll out scorecards to other areas.

Of particular interest is the increasing emphasis in developing the BSC through automation and software applications. Its influence has been further extended by information technology which supports its methodology and operation (Marr, 2001). In this context, Sanger (1998) indicated that the BSC has attracted considerable attention through the automation of this technique. Moreover, several software companies such as Gentia Software Inc, Peoplesoft Inc, and CorVu Corporation have developed programmes to assist in linking strategies to the BSC performance measurements (Gautreau and Kleiner, 2001). Martinsons et al. (1999) indicated that the evaluation methods that rely on financial performance measures are not suitable for the information technology applications. Therefore, they proposed the application of the BSC to measure and evaluate information technology application projects. As a result, the researchers are convinced that the BSC can be useful to information system managers as well as general managers. In addition, several researchers have emphasised the importance of this approach in many areas. In this context, Protti (2002) found that using the BSC allows managers to investigate the impact of information technology applications on the factors that are important to the National Health Services as a whole. Moreover, Wachtel et al. (1999) highlight that implementing the BSC in clinical services enables organisations to translate their missions into specific strategic objectives. In another context, Sandstrom and Toivanen (2002) indicate that if organisations implement the BSC this will result in helping the engineers in managing their product development and design.

Even though, the aforementioned literature seems to support that the BSC is widely used in companies, only limited systematic research has been conducted on the BSC applications (see for example, Otley, 1999; Norreklit, 2000; Ittner and Larcker, 2001). One reason is that most previous studies suffer from methodological shortcomings like a low response rates or unreliable estimates (Speckbacher et al., 2003). Moreover, in both theory and practice, quite different opinions exist on the characteristics of the balanced scorecard concept.

3.6.2 The balanced scorecard as a strategic management tool

Many researchers in management accounting agree with the notion that the BSC approach is a strategic management tool. This is because it helps senior managers to communicate their vision for change, while empowering business divisions and employees to devise new ways of completing the daily activities while accomplishing the company's strategic objectives (Epestein and Manzoni, 1998; Ritter, 2003). In addition, Malmi (2001) argued that one condition for a performance measurement system to be a BSC is that it should reflect business strategy. In this context, Otley (1999, p. 374-375) states that:

A major strength of the balanced scorecard approach is the emphasis it places on linking performance measures with business unit strategy.

Recent academic research (e.g. Mooraj et al., 1999; Ahn, 2001) confirms the role of this approach in strategy implementation and communication. In this context, Veen-Dirks and Wijn (2002) indicate that the choice of BSC perspectives depends on the strategy chosen, and the scorecard has been developed not to serve strategy formulation but to implement it, because the role of the BSC in strategy formulation is bounded. Empirically, the new report *Transforming Strategic Performance through the Balanced Scorecard* surveyed 200 companies in over 20 countries, these companies were found to have implemented a BSC as a framework for transforming strategy and vision into operational measures (Anonymous, 2001). In addition, a recent Institute of Management Accountants survey on performance shows that the scorecard is an effective strategy communication and clarification tool (Salterio and Webb, 2003). According to Bailey et al. (1999), the benefits from using the BSC as a strategic management tool are:

- Making organisational strategies updated and highly visible.
- Promoting the active formulation and implementation of organisational strategies.

- Improving communication within the organisation.
- Aligning annual or short-term operating plans with long-term strategies.
- Aligning performance evaluation measurement and long-term strategies.
- Improving alignment among divisional or individual goals and the organisation's objectives and strategies.

Conversely, few criticisms have been raised against the classification of this approach as a strategic management tool. For instance, Butler et al. (1997) indicated that this approach is too general, and may ignore corporate strategy and mission. Norreklit (2000) suggested that the BSC is not a valid strategic management tool. This results from the gap between the strategy expressed in the actions and the strategy planned. Recently, Sandstrom and Toivanen (2002) indicated that this approach has gained considerable popularity between organisations and researchers. Thus, they suggest the need to further examine its role with strategy. Indeed, it can be concluded from the literature review that one of the main assumptions to consider a performance measurement system to be a BSC is that the measures should be derived from business strategy by using a sequential cause-and-effect logic to link financial and non-financial performance measures.

3.6.3 The balanced scorecard as a cause-and-effect model

Many researchers (e.g. Epstein and Manzoni, 1997; McCunn, 1998) agree with the notion that the BSC is based on cause-and-effect relationships. As indicated by Martinsons et al. (1999), business strategy is a set of assumptions about cause-and-effect relationships, and these relationships can involve several or all four perspectives in the BSC. In this vein, McCunn (1998, p. 35) states that:

The innovation in this relationship is that the four perspectives of the balanced scorecard support the business model. If we have good people doing the right things then the customer will be happy and we will make more money.

Recently, interview data reported in a case study of a Fortune 500 company indicates managers believe the cause-and-effect relations included in their scorecard have led to improved efficiency and profitability (Salterio and Webb, 2003). Chang et al. (2002) argued that there is some preliminary evidence on the existence of the cause-and-effect relationships within the Performance Assessment Framework (PAF) of the National Health Service in the UK (quoted in Kasperskaya and Oliveras, 2003, p. 6).

In contrast, many researchers disagree with the assumption that the BSC approach is based on cause-and-effect relationships because this assumption is ambiguous and needs further elaboration (Otley, 1999; Norreklit, 2000; Malina and Selto, 2001; Ahn, 2001; Malmi, 2001; Laitinen, 2002). As discussed in Chapter 2, sub-section 2.6.1, several empirical studies conducted on the relationship between non-financial performance measures and future financial performance have produced mixed results. In addition, Kaplan and Norton (1996c) are theoretically unclear about the causal relationship, arguing both for a logical and causal relationship. Malina and Selto (2001) emphasised that there has been no rigorous, statistical test of the claim that the BSC is, in fact, a causal model. In the same context, Kasperskaya and Oliveras (2003) argued that the causality assumption has been criticised for not being properly justified and tested empirically. Recently, Norreklit (2003) argued that there is no cause-and-effect relationship between some of the areas of measurements in the BSC. She also highlighted that there is considerable covariation between customer loyalty and financial performance.

Malmi (2001) argued that performance measurement systems without cause-and-effect logic may also qualify as BSC approach. Empirically, Olve et al. (1999) found that some Swedish companies which have implemented an approach similar to Kaplan and Norton do not place emphasis on the causal relationship between the four perspectives. Recently, Ittner, Larcker and Randall (2003) found that 76.9% of companies claiming to use a BSC make little use of the causal relationship of leading and lagging indicators. Based on the above argument and considering the discussion so far, it can be concluded that the assumptions underlying the BSC, and the nature of the relationships between non-financial and financial indicators give a broad avenue for further research (Kaplan and Norton, 2001b; Kasperskaya and Oliveras, 2003).

3.6.4 The number of balanced scorecard perspectives and measures

In their writings, Kaplan and Norton (1996c, p. 34) argued that there is no specific theory that the number of perspectives is necessary and sufficient, in this context, they state that:

We have yet to see companies using fewer than these four perspectives, but, depending on industry circumstances and a business unit's strategy, one or more additional perspectives may be needed.

This argument has been supported by DeBusk et al. (2003), who indicated that the number of perspectives in a performance measurement system should depend on strategies, competitive threats, and economic conditions. However, Olve et al. (1999) proposed that the number of perspectives in the BSC is also situational. Researchers (e.g. Edvinsson and Malone, 1997; Schiemann and Lingle, 1999) have extended the four perspectives of the BSC by adding additional perspectives focused on employees, partners and suppliers and the environment (quoted in Ittner, Larcker and Randall, 2003, p. 717). In the same context, Olve et al. (1999) and DeBusk et al. (2003) have suggested that the environmental perspective could be another area of focus in the BSC. Moreover, Neely et al. (1995) indicate that the BSC has ignored the competitor perspective. Kaplan and Norton (1997), however, indicate that the employee perspective is certainly incorporated within the learning and growth perspective and the supplier perspective is incorporated within the internal business process perspective.

In another context, Kaplan and Norton (1992) indicate that each perspective of the BSC consists of a number of performance measures (i.e. between 16 to 20 measures). Based on a firm's strategy, the scorecard typically contains a diverse set of 16 to 28 performance measures organised into four perspectives (Salterio and Webb, 2003). In the same context, Olve et al. (1999) found that 15-20 measures are customarily used at the corporate and business unit levels. According to Chow et al. (1997), organisations that apply the BSC should recognise the relevant measures for their use based on the objectives and strategies they wish to attain. However, these performance measures are not necessarily comprehensive but should represent the critical success factors for the organisations (Otley, 1999).

Many researchers (e.g. Butler et al., 1997; Malina and Selto, 2001; Gautreau and Kleiner, 2001; Ahn, 2001; Sandstrom and Toivanen, 2002) have argued that using a thorough set of performance measures in the BSC may be distracting and confusing, particularly in calculating these measures, and also in dealing with the output of these measures. On the contrary, other researchers have argued that using these performance measures would not result in information overload (Otley, 1997; Clarke and Tyler, 2002; Ritter, 2003). Recently, Lipe and Salterio (2000) did not find evidence of information overload from multiple performance measures in their experimental study of the BSC. In the same context, Leauby and Wentzel (2002) argued that organisations cannot face problems in dealing with the performance measures of the BSC and some organisations have used 70 to 80 measures in their BSC. As a result, Kaplan and Norton (1996c) suggest that organisations should develop

and use financial and non-financial measures in each of the four perspectives that cope with organisation's goals and should stem from business strategy. Recently, Kaplan and Norton (2001c) suggest a breakdown for number of measures in each perspective and their relative weight (see Table 3.5). Based on the above argument and considering the discussion so far, it can be concluded the number of perspectives and performance measures used in the balanced scorecards are situational and depend on business strategy.

Table 3.5 Suggested number of measures in each balanced scorecard perspective. Source: Kaplan and Norton (2001c), p. 375

Perspective	Number of measures	Weight
Financial	5	22%
Customer	5	22%
Internal Business Processes	8 to 10	34%
Learning and Growth	5	22%

3.6.5 Balanced scorecard models

According to Kaplan and Norton (1993), each company is unique and so follows its own path for building a BSC. In their recent book, Kaplan and Norton (2001c) indicate that there are other scorecards types frequently used in practice, and the assumptions and philosophies that govern many of these scorecards are quite different from the original BSC. Thus, the following are the types of scorecards that have been identified by Kaplan and Norton:

- Stakeholder scorecards: This type of scorecards identifies different components of the organisation such as shareholders, customers, employees and other components (i.e. suppliers and the community). Kaplan and Norton (2001c) stress that the stakeholder scorecard does not describe the strategy of an organisation on which to build a management system, but it has been used effectively in practice.
- Key performance indicator scorecards: This type of scorecards is implemented frequently in organisations that have been adopting total quality management (Kaplan and Norton, 2001c).

In practice, many companies stress that they have a BSC because they have a mix of financial and non-financial performance measures. Other companies have worked with the original BSC but experiences vary (Roest, 1997). In this context, Olve et al. (1999) indicate

that scorecards have been used in different ways, however, a large number of companies have developed their own design and name for the model and sometimes use only part of it, but all have common features. Norreklit (2003) indicates that several performance measurement systems have been labelled BSC, although they do not have the assumptions of the Kaplan and Norton scorecard. Recently, Marcela et al. (2003) argued that there are two possible options to choose the indicators and perspectives; the first one refers to BSC as a model for control, and the second one uses the BSC as a model for making decisions or implementing properly the strategy of the company. Thus, the BSC can be used as a control tool focusing on key performance indicators, or as a strategic tool to integrate performance indicators to achieve organisation's strategy (Lawson et al., 2003b).

Many researchers (e.g. Malmi, 2001; Giannetti et al., 2002; Southern, 2002; Guenther and Gruening, 2002; Nielsen and Sorensen, 2003; Speckbacher et al., 2003) have found in their empirical studies that organisations are implementing the BSC in different ways. Therefore, the empirical research has to consider that the balanced scorecards' spread, content, implementation and applications are likely to vary depending on the type of balanced scorecard used (Speckbacher et al., 2003). Thus, it can be concluded that there is a need to conduct more empirical studies to investigate how, and to what extent organisations are implementing the balanced scorecard approach.

3.6.6 Balanced scorecard and compensation plans

In their first publications, Kaplan and Norton (1992) concentrated on the perspectives of the BSC, and how to implement it in the organisations, whilst not necessarily recommend linking the BSC to compensation plans. In their later publications, Kaplan and Norton (1996c) indicated that incentive compensation is a powerful tool to gain people's attention to achieve company's objectives. They did not, however, provide specific recommendations on how to link the BSC to compensation. Thus, Kaplan and Norton provided little guidance on how to combine or balance these performance measures when evaluating managerial performance. In 1996, Kaplan and Norton suggest that reward systems should sooner or later be linked to scorecard measures. In this context, they (1996c, p. 221) state that:

In expressing caution about using the balanced scorecard measures in formal compensation schemes, we do not advocate that such linkage not be used.

In practice, Kaplan and Norton (2000) found that of 15 companies using the BSC, 13 have linked their rewarding system to the BSC. Ittner et al. (2001), however, found that the implementation of a BSC compensation plan in a retail bank brought no significant change in understanding the strategic objectives by the managers. Nevertheless, many researchers (e.g. Ittner et al., 1997; Banker et al., 2000) have indicated that organisations should include both financial and non-financial performance measures in evaluating and rewarding managerial performance. Other researchers have also indicated that organisations that implement the BSC should link their compensation plans to the measures of the BSC (Chow et al., 1997; Epstein and Manzoni, 1998; Rucci et al., 1998; Otley, 1999; Ahn, 2001; Olivera and Amat, 2002; Leaby and Wentzel, 2002; Smith, 2002). Surveys by consulting firms suggest that an increasing number of large organisations are tying executive compensation of senior executives to BSC measures. In one survey, more than 60% of the 100 large organisations indicated that they linked the BSC to incentive pay for their senior executives (Epstein and Manzoni, 1998). Recently, Ittner, Larcker and Meyer (2003) found from a case study on a financial service firm that the use of subjectivity in weighting the measures in a BSC compensation plan allowed superiors to ignore many performance measures, so that financial performance became the primary determinant of compensations. Thus, linking scorecard measures to compensation and rewards system should be done with care (Lawson et al., 2003a).

Based on the aforementioned discussion, it can be argued that including compensation plans as a part of the BSC approach should add value to the organisation. The value of this approach is realised when the mission and strategy of the organisation are translated into performance measures that can be implemented, evaluated and rewarded at all levels of organisation.

3.7 Benefits and limitations of the balanced scorecard approach

The literature review concerning the BSC approach suggests that there are many benefits attributed to the use of this approach. These are summarised as follows:

- The BSC approach collects in a single report many of the seemingly disparate components of company's competitive agenda. Therefore, this approach satisfies several managerial needs (e.g. directing managers' actions towards the achievement of the long-term objectives).

- This approach provides a comprehensive framework for translating company's strategic goals into a coherent set of performance measures by developing the major goals for the four perspectives and then translates these goals into specific performance measures.
- This approach helps managers to consider all the important operational measures together. The scorecard lets managers see whether improvements in one area may have been at the expense of another.
- This approach improves communications within the organisation through making organisational strategy updated and highly visible and by promoting the active formulation and implementation of business strategies.

In addition, several empirical studies have examined the benefits from using the BSC. For example, Rigby (2001) shows that the BSC has utilisation rate of 44%. Moreover, Towers Perrin a consulting firm carried out a survey on the implementation of the BSC approach in 60 firms. The results showed that 64% reported that the satisfaction from this approach was higher than the satisfaction gained from other performance measurement systems (Ittner and Larcker, 1998a). According to Gartner Group, more than 40% of Fortune 500 businesses use the BSC to increase company performance (Paulsen, 2001). Recently, Lawson et al. (2003a) surveyed over 150 organisations, and the results showed that almost two-thirds of the respondents agreed that significant benefits had been realised from using the BSC approach.

Conversely, academics are more cautious to conclude in favour of the model's effectiveness (Kasperskaya and Oliveras, 2003). For example, some of them claim that 70% of balanced scorecard implementations fail (McCunn, 1998), while Anonymous (2001) reported that over half of the companies who claimed not to have adopted scorecards had never considered it and a further 40% that had examined the BSC had decided against implementation. The reason for not using it was the use of alternative approaches. However, the BSC has also attracted frequent criticisms and most of these are related to its assumptions. These are summarised as follows:

- Kaplan and Norton's BSC concentrates on four perspectives. However, several organisations may be affected by the environment and competitors. Thus, several researchers (e.g. Neely et al., 1995; Otley, 2001) have advocated using more perspectives such as supplier and environmental perspectives.

- Kaplan and Norton analysis revealed that organisations implement this approach in order to face the intensive global competition. In contrast, the level of competition may differ between organisations. Therefore, the adoption of the BSC is likely to vary between organisations.
- This approach neglects setting performance targets for the perspectives. Otley (1999) suggested that incorporating performance targets should be considered when implementing this approach.
- The cause-and-effect assumption has been introduced in a simplistic way, and the drivers that may cause the effects on performance are varied. Therefore, this assumption requires a trade-off among the drivers and the relationship between non-financial and financial measures needs further investigation.

3.8 An overview of the balanced scorecard approach

Clearly, the balanced scorecard (BSC) is a well-designed performance measurement system that integrates and complements traditional financial performance measures with non-financial performance measures that relate to customers, employees and other dimensions of performance to achieve organisational objectives. In viewing an organisation from different perspectives, the BSC is intended to link short-term operational control to the long-term vision and strategy of the organisation. Thus, the BSC is a complement, not a replacement, for an organisation's other performance and control systems (Simons, 2000, p. 202). The main strength of the BSC according to Marcela et al. (2003) consists in finding an appropriate balance between: (a) tangible and intangible drivers of performance (b) short and long-term goals and (c) internal and external perspectives of the company.

This approach has attracted much attention in the management accounting literature. The literature reveals that this approach has been implemented in different countries. Different aspects of this approach are also identified. They include integrating financial and non-financial performance measures of the four perspectives, the underlying assumptions of the scorecard and a critical examination of these assumptions. In addition, this approach has attracted a considerable amount of debate from researchers particularly determining the sort of measures to be adopted. In this context, Chenhall (2003, p. 130) states that:

It is not clear how balanced scorecards should be measured. It seems likely that the content and implementation of balanced scorecards vary widely between organizations.

In general, it should be noted that much of the research to date has focused on different aspects of the use of financial and non-financial performance measures on the one hand, and a critical analysis of the assumptions of the BSC approach on the other hand. However, in the face of increasing interest to the BSC, this research aims to investigate the extent of usage of BSC and how companies view the concept in terms of contents and assumptions. Finally, research adopting a contingency framework has been widely used in management accounting and management control system research (Dent, 1990). Closely related to the contingency theory perspective is the use of measurement techniques such as the balanced scorecard, economic value measurement and the causal business model (Ittner, Larcker and Randall, 2003). The management accounting literature also suggests that many contingent variables may influence different aspects of the BSC (Ittner and Larcker, 1998a; Chenhall, 2003). Thus, this research adopts a contingency theory theoretical framework to investigate the relationship between the contingent variables and the extent of balanced scorecard usage.

3.9 Summary

This chapter has presented a literature review on the balanced scorecard approach. It was pointed out that Kaplan and Norton introduced this approach in 1992. Noticeably, this approach is considered to be probably the most popular performance measurement framework that incorporates financial and non-financial performance measures. This is evidenced through the large number of publications and also through the percentages of adoption of this approach in different countries.

Building on the literature review, the balanced scorecard has attracted a few criticisms. So far there has been little debate pertaining to the assumptions of balanced scorecard. This debate as indicated by researchers has concentrated on the cause-and-effect relationships between perspectives, the balanced scorecard as a strategic management tool and the number of perspectives and measures in the scorecard. The research tends to outline grounds supporting the balanced scorecard usage. Similarly, a growing body of academic studies (Hoque and James, 2000; Malmi, 2001; Speckbacher et al., 2003) witnesses the current popularity of the balanced scorecard as a research subject. However, the management accounting literature (e.g. Olve et al., 1999; Malmi, 2001; Speckbacher et al., 2003) has indicated that this approach can be applied in different ways using different models.

Consequently, it should be noted that this research attempts to pay attention and learn more about the usage of the balanced scorecard in UK manufacturing companies. These issues will be discussed further in Chapter 5, which also aims to present the research hypotheses. The application of a contingency theory theoretical framework to explain the adoption of non-financial performance measures and the balanced scorecard has been advocated by several researchers such as (Ittner and Larker, 1998a; Hoque and James, 2000). Of particular interest for this research is the consideration given to the contingency theory theoretical framework in order to provide evidence on the contingency variables that may affect the usage of financial and non-financial performance measures and the balanced scorecard. Therefore, the next chapter seeks to examine the impact of these contingent variables through a review of the application of contingency theory theoretical framework.

Chapter 4

The contingency theory of management accounting

4.1	Introduction.....	4-2
4.2	The contingency theory of organisation structure.....	4-3
4.2.1	The effect of environment.....	4-4
4.2.2	The effect of technology.....	4-5
4.2.3	The effect of size.....	4-5
4.3	Organisational effectiveness and the concept of fit.....	4-6
4.4	The contingency theory of management accounting and control systems...	4-8
4.5	Limitations of contingency theory studies.....	4-13
4.6	A discussion of the contingency variables adopted in this study.....	4-15
4.7	An overview of the contingent variables, performance measurements and the balanced scorecard.....	4-17
4.7.1	Business strategy.....	4-18
4.7.2	Organisational structure.....	4-23
4.7.3	Perceived environmental uncertainty.....	4-26
4.7.4	Intensity of competition.....	4-28
4.7.5	Organisation size.....	4-29
4.7.6	Manufacturing practices.....	4-30
4.7.6.1	Total quality management.....	4-30
4.7.6.2	Just in time manufacturing approaches.....	4-32
4.8	Summary.....	4-33

Chapter 4

The contingency theory of management accounting

4.1 Introduction

It has been suggested in the previous chapters that the contingency theory approach is essential for understanding much of the diversity of usage of financial and non-financial performance measurements and the balanced scorecard approach. The identification of contingent variables potentially implicated in the design of management control systems can be traced to the original structural contingency frameworks developed within organisational theory (Chenhall, 2003, p. 128). As a consequence, the management accounting literature provides many contingent variables influencing the different aspects of performance measurements. With regard to the importance of these variables in explaining the emergence of contingency theory, no attempt however will be made here to cover all the related research concerning these variables. Instead, the chapter discusses the major contingent aspects related to the performance measurements and the balanced scorecard.

The aim of this chapter is to focus on explaining the influence of contingent variables on observed practices relating to different characteristics of management accounting control systems. In addition, the chapter aims to demonstrate the contingent variables that affect the usage of performance measurements and the balanced scorecard. This chapter is structured as follows: Sections 4.2 and 4.3 briefly review the emergence of contingency theory with its initial focus on organisation structure and organisational effectiveness and the concept of fit. Section 4.4 discusses the contingency theory of management accounting and control systems. This is followed by section 4.5, which discusses the limitations of management control contingency studies. Sections 4.6 and 4.7 discuss the contingent variables adopted in this study, and their relationship with performance measurements. Section 4.8 represents a summary and some concluding remarks. Finally, it should be emphasised that literature on contingency theory and management accounting systems is very wide and varied. As this study is concerned with financial and non-financial performance measurements and the balanced scorecard, the main focus of the study is on reviewing the literature on the contingent variables that are related to issues applicable to performance measurement.

4.2 The contingency theory of organisation structure

The contingency approach is an important perspective of organisation theory. This approach was developed in the organisation theory literature in the early to mid 1960s as a response to the rapid changes and increasing environmental uncertainty (Kreitner, 1998). The initial focus was on the impact of contingent variables on organisational structure. According to Daft (1992), contingency means one thing depends upon other things or that organisation characteristics depend upon the total situation. The theory aspect relates to a description that explains how organisational characteristics are causally related. Kreitner (1998, p. 55) defined the contingency approach as an effort to determine through research which managerial practices and techniques are appropriate in specific situations. Contingency theory states that an efficient organisation structure is contingent on an organisation's context (Waterhouse and Tiessen, 1978). In this context, Daft (1992) argued that organisational dimensions fall into two types:

- Structural dimensions to describe the internal characteristics of an organisation; these dimensions consist of formalisation, specialisation, standardisation, hierarchy of authority, complexity, centralisation, professionalism and personnel ratios. These dimensions also create a basis for measuring and comparing organisations.
- Contextual dimensions to characterise the whole organisation including its size, technology, environment, strategy, and culture.

Structural contingency theory suggests that organisations' structures are contingent upon contextual factors and a fit between their structures and contexts are in some sense more effective (Lawrence and Lorsch, 1967). Dimensions of organisation structure that have been studied include the degree of formalisation, specialisation, differentiation, integration and centralisation. According to Waterhouse and Tiessen (1978), the development of contingency theory of organisational structure was through the theoretical and empirical work of researchers such as Burns and Stalker (1961), Woodward (1965), Thompson (1967), Lawrence and Lorsch (1967) and Pugh (1973). Based on their research, they all indicate that the effectiveness of organisational structure is dependent on several contextual factors.

Contingency researchers have developed contingency theory related to organisational structure design, and the early research on contingency concentrated mainly on a few contextual factors such as the environment, technology and size. For instance, Woodward

(1965) indicated the importance of production technology as a primary determinant of organisational structure design. Burns and Stalker (1961) concentrated on the effect of organisational environment as a major determinant of structure. Tiessen and Waterhouse (1983) indicated that the essential argument in contingency theory is that organisational structure depends on the company's technology and environment. In this context, Waterhouse and Tiessen (1978, p. 66) state that:

Contingency theory essentially states that efficient organization structures vary with organizational contextual factors such as technology and environment.

The three general contextual factors of environment, technology, and size were used as prominent examples for the theoretical development of contingency theory. The following sub-sections provide a brief discussion of these variables.

4.2.1 The effect of environment

The environment variable includes several factors external to organisation such as economic, political and social. These factors have been used to explain differences in the use made of accounting information (Otley, 1980). Environmental uncertainty has been considered as the most important factor employed in the contingency literature (Mintzberg, 1979). Contingency studies (e.g. Burns and Stalker, 1961; Lawrence and Lorsch, 1967; Khandwalla, 1972; Otley, 1978) have described the influence of environmental uncertainty on organisational structure and design. These research efforts generally lead to the conclusion that mechanistic forms of organisation structure are associated with stable environments, while organic forms tend to succeed in dynamic environments. For instance, Burns and Stalker (1961) conducted an empirical investigation that identified environmental uncertainty as a key variable and formality and flexibility as styles of management. The findings of the study showed that organisations facing rapid change could best adapt by employing a flexible (organic) style, while the formal (mechanistic) style was the most appropriate for organisations facing stable conditions. Lawrence and Lorsch, (1967) conducted a study to examine what type of organisations are most effective under different environmental conditions. The sample of the study consisted of organisations from three different industries (plastic, food, and container). One of the main findings of the study showed that the greater degree of environmental uncertainty the greater the need for organisations to differentiate

their structures. Kandawalla (1972) found that increased perceived environmental uncertainty was correlated with less mechanistic structures for effective organisations.

4.2.2 The effect of technology

Organisation's technology is an important established contingent variable that influences the design of organisations in terms of production technology (Otley, 1980). Several major studies (e.g. Woodward, 1965; Perrow, 1967; Daft and Macintosh, 1978) have considered the effect of technology on organisation structure. For example, Woodward (1965) examined the relationship between organisational structure and production technical systems for 70 manufacturing companies using three production systems (mass production, process production and unit production). The main findings of the study showed that organisations using mass production were dealing with standard products with more emphasis on enhancing technology, and they depended on a differentiated structure. In contrast, organisations implementing unit production were dealing with non-standard products with less sophisticated production technology, and they depended on organic structures. Finally, organisations using process production were emphasising highly mechanised technologies, and they depended on organic structures. Furthermore, researchers (such as Thompson, 1967; Perrow, 1967) provide theoretical studies considering the technology to be a major factor in determining organisational structure.

4.2.3 The effect of size

Several earlier studies have investigated the effect of different contextual factors such as organisation size in addition to environment and technology. A programme of research aimed to identify different context measures such as size, ownership, technology, etc. was started in the Industrial Administration Research Unit of the University of Aston in the 1960s (Pugh, 1973). This stream of research attempted to examine the relationship between the dimensions of structure and different contingent variables, which include size, origin and history, charter, ownership and control, technology, location and interdependence. The results showed that the relationship between structure and the contingent variables is very important particularly in developing organisation's structure.

Consequently, the aforementioned early studies (e.g. Burns and Stalker, 1961; Woodward, 1965; Pugh, 1973) have contributed to the development of contingency theory approach. These studies have provided an indication of some of the factors that have been considered as affecting the structure of organisations. These studies, however, did not demonstrate any strong relationships between context, structure and organisational effectiveness or performance (Otley and Wilkinson, 1988). Researchers such as Van de Ven and Drazin (1985) and Gerdin and Greve (2004) indicated that there are several problems with contingency theory framework that have produced different results of contingency research. Most of these problems can be explored and resolved by concentrating on the main issues of contingency theory approach (Mintzberg, 1979). Organisational effectiveness or performance and fit are the most important issues that need to be developed and investigated by contingency theory researchers (Tosi and Slocum, 1984, p. 10). Therefore, the next section discusses the organisational effectiveness and the concept of fit.

4.3 Organisational effectiveness and the concept of fit

Organisational effectiveness has been introduced as an essential concept in contingency-based research. Structural contingency theory proposes that organisational effectiveness is a consequence of fit between two or more contingent variables such as environment, strategy, structure and culture (Van de Ven and Drazin, 1985). Conversely, Venkatraman (1989) defines fit as a match between two related variables, without reference to organisational effectiveness. According to Van de Ven and Drazin (1985), many earlier contingency theory researchers have only examined the organisational context-design link and have not included organisational effectiveness. Other researchers (e.g. Lawrence and Lorsch, 1967) have examined organisational effectiveness in their research design but in a narrow context (i.e. using only the profit). Moreover, defining organisational effectiveness by several criteria (e.g. flexibility and quality) may be more appropriate than depending only on profits (Tosi and Slocum, 1984; Govindarajan, 1988). However, organisational effectiveness is a potentially problematic concept to define because of the lack of a sufficient definition (Chenhall, 2003). In addition, there has been a lack of the careful development of the concept of fit. Thus, the definition of fit is central to the development of a contingency theory, to the collection of data and to the statistical analysis (Van de Ven and Drazin, 1985). In this

context, Van de Ven and Drazin (1985) argued that the concept of fit¹ can be categorised as follows:

- The selection approach: This approach maintains that the design of an organisation must adapt to the characteristics of its context, if it is to survive or to be effective. Moreover, this approach is useful for determining which contingency variables most significantly affect the design of organisation.
- The interaction approach: This approach examines organisational effectiveness through the interaction effects of pairs of variables. Furthermore, this approach to fit is appropriate for specifying bivariate² fit as well as the selection approach.
- The systems approach: This approach asserts on the multivariate fit between organisation design in simultaneous manner with many contingencies and organisational effectiveness or performance. Further, this approach to fit considers the concept of equifinality³.

It has been argued that several factors such as variable definitions and insufficient data have resulted in a contradictory theory (Dent, 1990; Fisher, 1995b). According to Ittner and Larcker (2001, p. 389), managerial accounting theories and frameworks provide little guidance on the correct method to measure the fit between managerial accounting practices and organisational characteristics. In addition to the aforementioned shortcomings, Gerdin and Greve (2004) argue that attention should be paid to the way concept of fit is applied and further theoretical and methodological issues are needed to identify which of the fit approaches is appropriate.

Thus far, it should be noted that the selection and interaction approaches to fit concentrate mainly on how single contingent variables affect single design characteristics, and how these pairs of context and design factors interact to explain organisational effectiveness or performance (Van de Ven and Drazin, 1985). In addition, the selection and interaction approaches are appropriate for specifying bivariate fit (Venkatraman, 1989). However, in comparison with the above approaches to fit the systems approach is the most embryonic consisting not of dominant, well-developed perspectives but rather of several novel

¹Several researchers (e.g. Venkatraman, 1989; Bergeron et al., 2001) have categorised the concept of fit into: (1) fit as moderation, (2) fit as mediation, (3) fit as matching, (4) fit as profile deviation, (5) fit as gestalts, (6) fit as covariation.

²The bivariate fit concentrates on how single contextual factors affect single design characteristics, and how these pairs of context and design factors interact to explain performance (Van de Ven and Drazin, 1985, p. 347).

³Equifinality means that organisational effectiveness can be achieved through multiple organisational structure, even if the contingencies facing organisation are the same (Al-Dahiyat, 2003).

alternatives tied together by their interest in characterising the holistic patterns of interdependencies that are present in social systems (Van de Ven and Drazin, 1985, p. 347). Recently, Bergeron et al. (2001) found in their empirical work that the systems approach of fit is richer and will provide fuller explanation than bivariate approaches. As a result, a more complex but richer approach to the analysis of fit may be necessary. However, the systems approach focusing on a multivariate pattern of fit among context and design characteristics may yield the most meaningful information (Van de Ven and Drazin, 1985, p. 359). Therefore, the systems approach was utilised in this research as a measure of fit.

4.4 The contingency theory of management accounting and control systems

Management accounting systems are an integral part of the control structure of organisations. Contingency theory has expanded the management planning and control by articulating the contingent variables that influence the organisational design and accounting and non-accounting information systems (Gordon and Miller, 1976). Contingency-based research has a long tradition in studying management control systems (Chapman, 1997; Chenhall, 2003). In this context, Otley (1980, p. 413) states that:

The contingency approach to management accounting is based on the premise that there is no universally appropriate accounting system applicable to all organisations in all circumstances. Rather a contingency theory attempts to identify specific aspects of an accounting system that are associated with certain defined circumstances and to demonstrate an appropriate matching.

Management accounting using a contingency approach has attempted to relate a range of contextual factors such as perceived environmental uncertainty (e.g. Gordon and Narayanan, 1984; Govindarajan, 1984), technology (e.g. Chenhall and Morris, 1986), strategy (e.g. Govindarajan and Gupta, 1985; Simons, 1987) with the design of management accounting system. Researchers such as Hayes (1977) and Waterhouse and Tiessen (1978) have argued that the nature of an appropriate accounting system depends on several circumstances in which an organisation finds itself. In this context, Waterhouse and Tiessen (1978) suggested a model for contingency research on management accounting system design, which is concerned with illustrating the possible relationships between organisational design and the effective design of management accounting system and organisational effectiveness (see Figure 4.1).

Figure 4.1 A model for contingency research on management accounting system design. Source: Otley (1980), p. 420

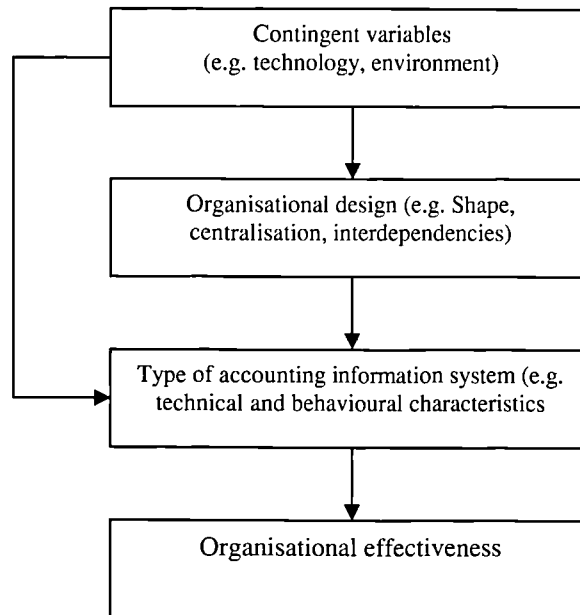

In relation to this model, several researchers (e.g. Kandwalla, 1972; Hayes, 1977) have considered the possibility of a direct relationship between the contingent variables and accounting information design either alone or in conjunction with organisational structure. In this context, Gordon and Miller (1976, p. 571) state that:

In fact, due to the contingent nature of a well designed A.I.S., we believe that no one prescribed system could ever be effective in all circumstances

In applying contingency theory to control system design, Dent (1990) argued that some researchers have used the direct relationship without considering organisational structure, and other researchers have used the structure as an intervening variable. Otley (1980) indicated that the relationship between the contingent variables and the accounting information system is weak because the same contingent variables are likely affect both accounting system design and structure. In addition, Otley (1980, p. 425) argued that it appears unwise to use structure as the sole intervening variable between contingent variables and the choice of the accounting information system. Also, no single study had combined all four stages in the model shown in Figure 4.1. In another context, Chenhall (2003) argued that several studies have used the effectiveness as a dependent variable and other studies have not. He also indicated that researchers use both approaches, but care is required in following either approach. The debate concerning contingency-based accounting control studies has thus focused on whether organisational structure should be included as a contingent variable

and also whether organisational effectiveness should be incorporated as the dependent variable. However, contingency-based research has not yet developed a comprehensive contingency theory of accounting (Chapman, 1997). Thus, it can be noted that there is no comprehensive approach for contingency studies. However, contingency theory framework is adopted to assist managers in achieving organisational objectives, but this depends on the appropriate design of management control system. The appropriate design of management control system will be influenced by a set of contextual factors. In this vein, Otley (1999, p. 367) states that:

Contingency theory of management accounting suggests that there is no universally applicable system of management control, but the choice of appropriate control techniques will depend upon circumstances surrounding organizations.

Merchant (1998, p. 728) indicated that the contingency theory of management accounting, which is mainly concerned with control systems design, implies that there is no universally best management control system which applies to all situations in all organisations. He also argued that managers must consider different contingent variables while they are designing, implementing and using management control systems. Thus, Merchant (1998) has depicted a general contingency framework (see Figure 4.2), in which the contingent variables influence the design of management control system and the match between the contingent variables and management control system characteristics will result in various control outcomes.

Figure 4.2 A general management control system contingency framework. Source: Merchant (1998), p. 728

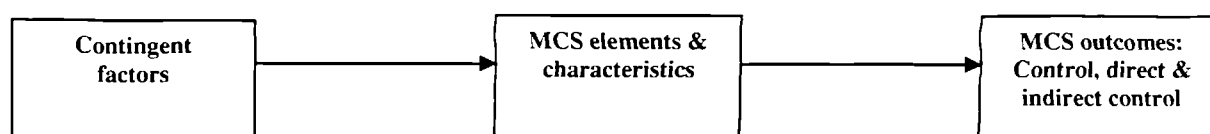

As mentioned earlier, there is no best management control system design that bears with all situations in all organisations. Thus, it is expected that different organisations will have several organisational design and processes. However, several contingent variables have been suggested in the literature of management accounting to influence the choice and design of management control system. In this context, many researchers (e.g. Fisher, 1995b; Merchant, 1998) argue that the uniqueness of organisations has contributed to a range of contingent variables, and this led to a difficulty in studying each variable separately. Thus, researchers have classified these contingent variables into categories. For example, Fisher (1995b)

classified the contingent variables into five broad categories (see Table 4.1). This broad category of contingent variables influences the design of management control system implemented by the organisation (Merchant, 1998).

Table 4.1 Contingent variables grouped by major categories. Source: Fisher (1995b), p. 30

<ul style="list-style-type: none"> • The external environment <ul style="list-style-type: none"> - Uncertain and certain - Static and dynamic - Simple and complex - Turbulent and calm • Competitive strategy and strategic mission <ul style="list-style-type: none"> - Low cost and differentiation - Defender and prospector - Product life cycle (build, hold, harvest, and divest) • Technology <ul style="list-style-type: none"> - Small batch, large batch, process production, mass production - Interdependence (pooled, sequential, reciprocal) • Business unit, firm and industry variables <ul style="list-style-type: none"> - Firm size - Firm diversification (single product, related diversified and unrelated diversified) - Organisational structure - Industry variables • Knowledge and observability factors <ul style="list-style-type: none"> - Knowledge of the transformation process - Outcome (output) observability - Behaviour (effort) observability
--

The first category in Table 4.1 consists of variables related to the external environment. This category has been widely used in contingency theory literature as the main determinant of organisational design (Waterhouse and Tiessen, 1978). According to Drury (2002), contingency variables under this category are mainly concerned with the level of uncertainty. Merchant (1998) indicates that uncertainty is most often studied in management control contingency research. The perceived environmental uncertainty has been identified as an important contextual factor because it makes managerial planning and control more difficult according to the unpredictability in the future events (Chenhall and Morris, 1986).

The second category of contingent variables is related to competitive strategy and mission factors. According to Langfield-Smith (1997), strategy variables include:

1. Corporate strategy that is concerned with determining the type of business to operate in and it is studied at the corporate level of organisations.
2. Business unit strategy that is concerned with how organisations with high level of functions compete within the industry.

3. Operational strategy that is concerned with how different functions in the same organisation sustain in implementing competitive strategy.

Whilst, strategic mission is concerned with the stages of product life cycle (i.e. build, hold, harvest and divest). These stages show the organisation's intended trade-off between market share growth and maximising profits (Langfield-Smith, 1997). The build strategy is concerned with improving market share more than maximising profits. The harvest strategy depends on maximising profits and cash flow more than improving market share. A hold strategy concentrates on protecting the existing market share and achieving reasonable profits. The divest strategy occurs when organisation starts to withdraw from the market (Drury, 2004).

The third category of contingent variables is concerned with technology and interdependence. These variables were developed by the early contingency theorists such as Thompson (1967), and were used as crucial contingent variables to study at structural level. Technology was classified in the literature by Woodward (1965) as small batch, large batch, process production and mass production.

The fourth category of contingent variables is concerned with organisational and industry variables such as organisational structure, size and culture. According to Chenhall (2003), organisation structure plays a major role in understanding management control system design. The contingency theory literature suggests that organisation size may affect the design of organisational structure and the use of management control systems (Merchant, 1984). Moreover, Fisher (1995b) indicates that management control systems are different depending on the type of industry. In this context, Drury (2002) argued that manufacturing companies are expected to design their control system in different ways than non-manufacturing companies.

The fifth category of contingent variables is concerned with knowledge and observability factors. These factors are related to the types of control that are dependent on the knowledge of the transformation process. This category is also concerned with linking the factors with the appropriate type of performance assessment (Drury, 2002). Furthermore, these factors examine the relationship between accounting information and uncertainty about objectives.

However, the five categories mentioned in Table 4.1 can be either internal or external to organisations, and can affect organisational outcomes, performance measurement, resource allocation and the distribution of rewards (Sisaye, 1998).

Finally, it should be noted that contingency theory has resulted in a continuing stream of studies⁴ seeking to explore the contingent nature of accounting. In addition, the application of the contingency theory framework to the analysis and design of organisational control systems has generated a considerable amount of interest. Thus, accounting researchers have invoked contingency theory when studying the relationship between organisational factors and the design of management control system (Widener, 2004). Management accounting system, which are considered to be a subsystem within the control system of the organisation, have been the subject of many empirical studies, but these studies have several limitations. Thus, the next section discusses the limitations of contingency theory studies.

4.5 Limitations of contingency theory studies

Most of the limitations of contingency theory studies relate to how the theory has been applied rather than its basic underlying theoretical framework. Management accounting contingency research has mostly attempted to correlate one contingency variable with one control factor. According to Fisher (1995b), the major weakness of contingency theory studies is that they examine only one contingent variable and one control attribute. Instead, a study of multiple contingent variables and multiple control system design is required to determine the effectiveness of control system design. In the same context, Otley and Wilkinson (1988, p. 167) state that:

Accounting control systems cannot be usefully studied in isolation, but must always be considered in the context of other controls operated within an organization.

Earlier, it was pointed out that Otley (1980) has indicated that no single study has combined all four stages in the contingency theory framework. Typically, the studies have focused only on the relationship between contingent variables and accounting information system design

⁴ Two streams of contingency studies of accounting were presented by Chapman (1997), the first stream of studies (e.g. Hopwood, 1972; Otley, 1978) has concentrated on the role of the use of accounting information in performance evaluation. The second stream of studies (e.g. Gordon and Miller, 1976; Gordon and Narayanan, 1984; Gul and Chia, 1994) has been concerned with how accounting systems might be affected by a variety of contingent variables. However, a useful discussion of these two streams of research may be found in Chapman (1997).

without considering organisational structure as an intervening variable. In addition, Otley (1980) and Fisher (1995b) criticised the contingency studies because they tend to use characteristics of the formal accounting information control system as a proxy for organisation's management control system, while the formal accounting control system represents only one part of the total control system⁵.

The literature on contingency theory emphasises the need to consider organisational effectiveness as a vital part of a contingency control system design. Contingency-based research has investigated management control system as both dependent and independent variables to examine the fit between the contingent variables and management control system (Otley and Wilkinson 1988). For example, some contingency studies (e.g. Hayes, 1977; Merchant, 1984; Simons, 1987) have examined organisational effectiveness. However, most contingency studies (e.g. Kandawalla, 1972; Gordon and Miller, 1976; Waterhouse and Tiessen, 1978) have ignored organisational effectiveness as an outcome variable. In addition, studies have measured organisational effectiveness 'performance' using different methods. For example, Simons (1987) indicated that effectiveness could be measured by financial performance measures, whereas the American Accounting Association (AAA) recommended the use of non-financial indicators as measures of effectiveness (AAA, 1971). Recently, Hoque and James (2000) emphasised that measuring organisational effectiveness should depend on both financial and non-financial performance measures. Furthermore, some of the studies that have investigated management accounting innovations (e.g. activity-based costing systems) have highlighted that there is no observational research that can prove a causal relationship between improving performance and implementing activity-based costing systems (Kennedy and Graves, 2001). Cagwin and Bouwman (2002), however, have argued that a match between contingent variables and activity-based costing systems or the balanced scorecard can be related to improved performance. In the same context, Ittner and Larcker (1998a) indicate that the effectiveness of the balanced scorecard is measured by the extent to which respondents are satisfied with this approach compared with the performance measurement system used in the past.

⁵ The terms management accounting information systems, management accounting control systems and management control systems are often used interchangeably in the contingency theory literature even though it is possible to distinguish between them. Management accounting information systems refer to a collection of practices that incorporate aspects of management accounting information for both decision-making and control. Management accounting control systems relate to the collection of accounting practices (typically results or output controls) that are used mainly for control purposes. Management control systems represent a broader term that encompasses management accounting control systems but also includes other controls such as behavioural, personal and social controls (Drury, 2004, p. 698).

Problems also apply in defining and measuring the contingent variables. Many of these variables are theoretical concepts that are not capable of direct measurement such as perceived environmental uncertainty and business strategy (Ittner and Larcker, 2001; Chenhall, 2003). Therefore, the contingent variables are subject to measurement error⁶ and this will yield to misstatement of the true relationship. Finally, Chapman (1997) and Fisher (1998) argued that contingency studies have relied excessively on cross sectional and postal questionnaire based research to examine the relationship between the variables. The reason for using this type of research is due to firm's resistance in providing data. Therefore, many researchers are forced to obtain data through surveys that may have bias and reliability issues. Despite the above limitations, contingency-based research has been widely used in the study of management control system.

4.6 A discussion of the contingency variables adopted in this study

Contingency theory argues that the design and use of control systems is contingent on several contextual factors, but determining the appropriate set of factors is always controversial. In this context, Macintosh and Daft (1987) indicated that there is no single study that can assess all the contingent variables. In the same vein, Fisher (1998, p. 49) argued that there has been very little work to identify the appropriate contingent variables, and most of contingency variables included in empirical control studies have been selected on an ad hoc basis. Recently, Chenhall (2003, p. 127) indicated that researchers have attempted to explain the effectiveness of management control systems by examining designs that best suit the nature of environment, technology, size, structure, strategy and national culture.

Earlier Euske et al. (1993) stressed that performance measures appear to be a contextually defined phenomenon, and the same measures may have different meanings and impacts in different organisations. Moreover, Ittner and Larcker (2001) emphasised the need to study the relationship between non-financial performance measures and the contingent factors. In this context, they indicate that non-financial value driver studies also ignore contingent factors. They also argued that the choice of performance measures is a function of the organisation's competitive environment, strategy, and organisational design. Maltz et al. (2003) argue that the appropriate set of performance measures depends on the firm's size, technology, strategy, industry and environment in which a firm operates. In addition, the

⁶ See Chapter 6 (sub-section 6.14.3) for an explanation of measurement error concept.

study of Widener (2004) found that contingency theory provides an understanding for the implementation of non-traditional controls. Many researchers (e.g. Chenhall and Langfield-Smith, 1998a; Ittner and Larcker, 1998a; Otley, 1999; Chenhall, 2003) have indicated the importance of examining the relationship between contingent variables and the balanced scorecard. In this context, Ittner, Larcker and Randall (2003, p. 716) state that:

Closely related to the contingency perspective is the use of measurement techniques such as the balanced scorecard process, causal business modeling, and economic value measurement

The balanced scorecard (Kaplan and Norton, 1992) is said to be a more appropriate approach under the new realities of competition, organisation design and the strategic needs of organisations (Marcela et al., 2003). Recently, De Waal (2003) argued that research is needed into environmental and organisational factors that influence the successful implementation of the balanced scorecard. Most of the research adopting a contingency theory framework has focused on different aspects of management accounting control systems, and it has rarely been applied to explaining the adoption of balanced scorecard. Therefore, this research considers the contextual factors that influence different aspects of performance measures and the balanced scorecard.

Building on the aforementioned literature, this research considers environmental uncertainty and the intensity of competition as contextual factors from the external environment category. As this research is primarily concerned with financial and non-financial performance measures and the balanced scorecard, the competitive business strategy is considered as another contextual factor from the competitive strategy and strategic mission category. From the technology category the research takes into consideration the new manufacturing practices such as total quality management and just in time manufacturing approaches because of its relationship with non-financial performance measures. Finally, the research considers organisational structure and size as the most important factors in the business unit, firm and industry category. Further, the contingency theory literature has been mainly concerned with firms in manufacturing industry. Therefore, this research also focuses on the usage of performance measures and the balanced scorecard in organisations operating in the manufacturing sector. In addition, a further justification for focusing only on the manufacturing industry is provided in Chapter 6, section 6.4.

Having discussed the association between management control systems and the contingent variables, the following section explores the relationship between performance measurements, the balanced scorecard and the contingent variables based on a review of the empirical and theoretical studies. The aim is to draw off the literature review to provide an insight about the relationship between the contingent variables, performance measurement systems and the balanced scorecard approach.

4.7 An overview of the contingent variables, performance measurements and the balanced scorecard

Contingency research has mainly sought to explain how management accounting control systems (such as budget use, budget evaluation styles, and performance appraisal system) are influenced by different contingent variables. A major strand of management accounting research has been the application of contingency theory to the study of management accounting systems design and performance (Chenhall and Morris, 1986). According to Ittner, Larcker and Randall (2003), the research on contingency approach to strategic performance measurement falls into the following categories:

- A first set of studies that have focused on the influence of perceived environmental uncertainty on performance measurement system attributes (e.g. Larcker, 1981; Gordon and Narayanan, 1984; Chenhall and Morris, 1986). These studies have provided mixed results and none of the studies have investigated organisational performance.
- A second set of studies that have focused on the effects of organisational strategy on performance measurement choices, and the relationship between these choices and organisational performance. The majority of these studies have found a significant relationship between strategy and performance measurement systems and a smaller set have also linked this relationship to higher organisational performance (e.g. Govindarajan and Gupta, 1985; Simons, 1987; Govindarajan, 1988).
- A third set of studies have shown an association between new manufacturing practices (such as quality and flexibility), the choice of performance measures and manufacturing performance. Mixed results on the performance benefits from these measurement practices have been reported (e.g. Abernethy and Lillis, 1995; Ittner and Larcker, 1995; Sim and Killough, 1998).

This section aims to provide a brief review of the findings from the empirical studies relating to characteristics of management accounting control systems (with specific reference to performance measurement) adopting a contingency theory framework by considering business strategy, organisational structure, perceived environmental uncertainty, intensity of competition, size and new manufacturing practices (i.e. TQM and JIT) as contingent variables. This section is divided into sub-sections to discuss and explain the study's choices of the contingent variables that might exhibit a contingency relationship with performance measurements and the balanced scorecard.

4.7.1 Business strategy

The term strategy is widely employed in a variety of disciplinary literature (Dent, 1990). Several definitions of strategy have been used in the literature ranging from the general to specific, but as mentioned in the previous section this study is concerned with business competitive strategy. Porter (1980) defines the competitive strategy as a search for a favourable competitive position in an industry. It aims to establish a profitable and sustainable position against the forces that determine industry competition. Business strategy was developed by different researchers and elaborated on by others. Porter (1985) recognises that a business can develop a sustainable competitive advantage by implementing one of the following strategies:

1. **Cost leadership strategy:** It implies that the organisation aims to become the lowest-cost producer in its industry. The source of this competitive advantage may arise from factors such as economies of scale in production, experience curve effect, superior technology and cost control.
2. **Differentiation strategy:** It focuses on providing products or services that customers perceive as being unique. These include superior quality, product flexibility, delivery and product design.
3. **Focused strategy:** In this strategy organisation dedicates itself to a segment of the market that has special needs that are poorly served by the competitors. This is based upon either low cost or differentiation.

Miles and Snow (1978) identify four generic strategic types of organisations according to the rate of change in products or markets. These strategic types are prospector, defender, analyser and reactor. Prospectors are characterised by vitality in searching for market

opportunities and the product-market domain, in which the organisation can gain benefits from launching new products, market developments and by also focusing on customer satisfaction and research and development. Defenders concentrate on stable product areas, limited products than competitors with high production volume and low diversity. Analysers are an intermediate, combining several characteristics of both prospectors and defenders. Reactors do not follow a conscious strategy.

Business strategy has been recognised as an important variable in the contingency literature (Chenhall, 2003). More specifically, accounting control systems should be designed specifically to suit the business strategy of the organisation (Otley, 1980). The management accounting literature suggests that the choice of performance measures is dependent upon business unit strategy (Abernethy and Lillis, 1995) and the nature of performance measurement system is different according to the strategy selected (Cauvin and Bescos, 2002). The objectives of non-financial performance measures are to achieve long-term competitive advantage, and these measures depend on the strategy and objectives of management (Hussain and Gunasekaran, 2002).

In terms of strategic mission, Merchant (1984) argued that organisations with products in the early stages of product life cycle tend to place less emphasis on the use of traditional financial control tools than organisations with products in the later stages. Empirically, Govindarajan and Gupta (1985) found that business units following a build strategy rely more on non-financial performance measures such as new product development, market share and personnel development for determining managers' bonuses than those following harvest strategy. Recently, Hoque and James (2000) examined the influence of product life cycle on the usage of the balanced scorecard. The findings showed a positive association between early product life cycle stage and greater reliance on the balanced scorecard approach. More recently, Verbeeten (2004) found that a build strategy was positively associated with the use of non-financial performance measures.

In terms of the Miles and Snow typology, Simons (1987) conducted a study to examine the relationship between business strategy and accounting control systems. He argued that defenders place heavier reliance on formal accounting procedures, especially those directed to cost control, while prospectors emphasised fostering individual creativity and innovation. The findings of the study showed that high performing prospectors pay high attention to data

forecasting in control systems, setting tight budget goals and monitoring outputs, and also they use their financial controls more intensively than defenders. Defenders appear to use their control systems less intensively also tending to have little change in their control systems. High performing defenders also awarded bonuses for the achievement of budget targets. These results appear quite surprising because it's different from the propositions of Miles and Snow (1978) who argue that defenders emphasise controls mainly on cost whereas prospectors use performance measures more subjectively. Ittner et al. (1997) found the relative weight placed on non-financial performance measures is greater in organisations following prospector strategy than in organisations following defender strategy. In contrast, Morissette (1998) found no relationship between financial and non-financial information and the strategy of the business, in which strategy is measured by the prospector versus defender continuum. Guilding (1999) adds evidence that strategy is an important determinant of control systems and performance measurement. In his study, he found that prospector organisations, and organisations following a build strategy make greater use of competitor assessment systems and perceive these systems to be more useful than defenders and organisations following a harvest strategy. Anderson and Lanen (1999) conducted a study to explore the evolution of management accounting practices in India. They found that prospectors focus more on performance measures such as customer satisfaction, market share and competitors' performance than defenders.

Business strategy affects organisations' needs for management accounting innovations (Gosselin, 1997). In this context, Gosselin (1997) found that prospector strategy is associated with managers' decisions to adopt an activity management approach. In the same vein, Olson and Slater (2002) conducted a survey to measure the competitive strategy type adopted by the organisation and the emphasis placed on each dimension in the balanced scorecard, and the overall perceived performance of the organisation. The findings of the study were as follows:

- Prospectors emphasised the innovation and growth perspective more than any of the other strategy types. There were also no significant differences between high and low performers regarding the emphasis placed on the innovation and growth perspectives. Moreover, high-performing prospectors pay more attention to the customer perspective than low performers.
- High-performing analysts place greater emphasis on both innovation and financial perspectives than do low-performing analysts. Also high-performing analysts pay more attention to the internal business perspective than low-performers.

- High-performing low cost defenders place greater emphasis on the financial perspective than do low-performers, also they place lower emphasis on both customer and innovation perspectives than do lower performers.
- High-performing differentiated defenders place greater emphasis on the customer perspective, also they emphasize the innovation and financial perspectives more than low-performers.

Recently, Sohn et al. (2003) conducted a survey to examine the relationship between several contextual factors and the usage of the balanced scorecard perspectives. They found that defenders place higher weight on the perspectives of financial and internal business processes than prospectors, while, prospectors place a higher weight on customer and learning and growth perspectives than defenders. They also found that reactors place a higher weight on the financial perspectives and analysers do not exhibit any clear pattern. In terms of Porter's classification, Shank (1989) argued that many management techniques and management accounting practices may provide benefits to organisations emphasising either product differentiation or low cost strategies, however, different managerial mind sets underlying differentiation and low cost strategies may influence preferences for particular management accounting practices. He also indicates that traditional performance measures are inadequate to assessing how the production process supports a variety of customer focused strategies for organisations following differentiation strategy. Shank (1989) summarised the influence of both strategies on cost analysis perspectives. These perspectives are illustrated in Table 4.2.

Table 4.2 Generic strategies and management accounting. Source: Shank (1989), p. 55

	Product differentiation	Cost leadership
Role of standard costs in assessing performance	Not very important	Very important
Importance of such concepts as flexible budgeting for manufacturing cost control	Moderate to low	High to very high
Perceived importance of meeting budgets	Moderate to low	High to very high
Importance of marketing cost analysis	Critical to success	Often not done at all on a formal basis
Importance of product cost as an input to pricing decisions	Low	High
Importance of competitor cost analysis	Low	High

Several contingency studies have focused on the relationship between business strategy and performance evaluation and reward systems. Govindarajan (1988) found that high performing organisations following a low cost strategy awarded bonuses for the achievement of budget targets. Moreover, Gupta (1987) found that subjective performance evaluation was

appropriate for organisations following a differentiation strategy. In another context, Drucker (1990) emphasised the importance of traditional performance measures and their suitability for organisations following low cost strategy. According to Brignall (1997) and Guenther and Gruening (2002), the advanced performance measurement systems should be adjusted to the strategy of the business unit. For example, cost leadership strategy needs other performance measurement systems compared with quality leaders and the use of non-financial performance measures may be more appropriate for a differentiation strategy compared with a low cost strategy. Cauvin and Bescos (2002) argue that if quality and time become essential strategic criteria, financial performance measures are inadequate to manage organisations in the long run. This doesn't mean that accounting measures are not useful. They must be complemented by non-financial measures.

Empirically, Van der Stede et al. (2001) found no relationship between business strategy (i.e. differentiation versus low-cost) and the increased use of non-financial measures in a survey of 128 Belgian and US managers. Only the customer-oriented non-financial measures were used more with a differentiation strategy. In the same context, Chenhall and Langfield-Smith (1998b) used Porters strategies to identify the benefits from several management accounting practices. One of the study findings showed that organisations following a differentiation strategy gain high benefits from new management accounting techniques such as balanced performance measures. Also higher performing organisations that place a strong emphasis on a low cost strategy gain benefits from traditional accounting techniques. Recently, Baines and Langfield-Smith (2003) found that the change towards a differentiation strategy would not lead into a greater reliance on non-financial management accounting information. Widener (2004) found that strategic choices influence the design of non-traditional results controls within the management control system. Moreover, the results suggest that companies are adding non-traditional controls to their traditional management control system. This finding is consistent with the notion of the balanced scorecard (Widener, 2004). Other researchers (e.g. Otley and Wilkinson, 1988; Langfield-Smith, 1997) have indicated that the effect of business strategy on control systems design is unclear and that researchers' knowledge of the relationship between management control systems and strategy is limited. Thus, there is a need for empirical studies to explore how performance measurements may be used under different strategies. This research attempts to explain further the impact of business competitive strategy on the extent of usage of both performance measurements and the balanced scorecard.

4.7.2 Organisational structure

The term organisational structure is considered to be an important aspect within the internal context that influences the design of management accounting systems. There have been various definitions and distinctions of organisational structure⁷. For instance, Lawrence and Lorsch (1967) refer to structure as the way in which an organisation is differentiated and integrated. Differentiation is concerned with the extent to which sub-unit managers act separately whereas integration refers to the extent to which sub-units act in ways that are consistent with organisational objectives. Similarly, Mintzberg (1979, p. 2) defines structure as the sum of the ways in which an organisation divides its labour into distinct tasks and then achieves co-ordination among them.

It appears from the aforementioned definitions that organisational structure⁸ is mainly concerned with two opposing requirements, differentiation and the integration of tasks to achieve organisational objectives. In another vein, Burns and Stalker (1961) discuss structure generally in terms of mechanistic and organic approaches. A mechanistic management system is structured, and behaviour is standardised and appropriate to stable conditions. The organic form is characterised by informal working relationships and is appropriate to changing conditions. Daft (1992) summarised the main characteristics of both approaches. This is illustrated in Table 4.3.

Table 4.3 Mechanistic and organic organisation forms. Source: Daft (1992), p. 83

Mechanistic	Organic
1) Tasks are broken down into specialised, separate parts.	1) Employees contribute to the common task of the department.
2) Tasks are rigidly defined.	2) Tasks are adjusted and redefined through employee teamwork.
3) There is a strict hierarchy of authority and control, and there are many rules.	3) There is less hierarchy of authority and control, and there are few rules.
4) Knowledge and control of tasks are centralised at the top of organisation.	4) Knowledge and control of tasks are located anywhere in the organisation.
5) Communication is vertical.	5) Communication is horizontal.

The importance of including organisation structure in contingency research is based upon its influence on the efficiency of work, the motivation of employees, control systems and information flows (Chenhall, 2003). The choice of organisation structure in contingency

⁷ A useful discussion of these definitions and distinctions may be found in Chenhall (2003, p. 19).

⁸ Formalisation, specialisation, standardisation, hierarchy of authority, complexity, centralisation, professionalism, and personnel ratios are the key structural dimensions. However, a useful discussion of these dimensions may be found in Daft (1992).

research has been widely used in the early contingency studies to examine the relationships between structure and contingent variables such as external environment, technology and the size (Otley, 1980). Moreover, contingency research has focused on the appropriate fit between organisation structure and the environment (e.g. Burns and Stalker, 1961), technology (e.g. Thompson, 1967) and size (e.g. Pugh, 1973). Thus, it can be noted that organisation structure has been identified as an important variable in evaluating contingency relationships between management control system and the contextual factors (Chenhall, 2003).

Considerable attention has been paid to the choice of performance measures. However, the association between structural variables and performance has been ignored in the literature (Dalton et al., 1980). Several studies have investigated the association between the organisation structure issues and performance measures (Ittner and Larcker, 2001). Researchers (e.g. Gordon and Miller, 1976; Waterhouse and Tiessen, 1978) have argued that decentralisation is an appropriate response to dynamic environments and that broad scope, non-financial information is required. Empirically, Hayes (1977) found that performance measures of highly interdependent subunits were most useful when they include measures to assess managers' reliability, co-operation and flexibility. Scott and Tiessen (1999) report a positive relationship between the proportion of time spent in teams and the diversity of performance measures (both financial and non-financial) used in companies. Gordon and Narayanan (1984) investigated the relationship between management accounting system, perceived environmental uncertainty and organisation structure. The study showed that there is a significant correlation between organic form of organisations and the perceived importance of external, non-financial information, but after controlling the effect of environment, it does not appear that an organisation's information system and structure are significantly correlated. Chenhall and Morris (1986) examined the effect of decentralisation, perceived environmental uncertainty (PEU) and interdependence on management accounting system design⁹. One of the study findings showed that broad scope and timely information were not significantly associated with decentralisation.

⁹ Chenhall and Morris (1986, p. 19) defined management accounting system design in terms of the perceived usefulness of several information characteristics. These characteristics include: scope (i.e. external information, non-financial information and future-oriented), timeliness (i.e. frequency of reporting and speed of reporting), aggregation (i.e. aggregated by time, aggregated by functional area and decision models) and integration (i.e. precise targets for activities and reporting on intra-sub-unit interactions).

Furthermore, Chia (1995) carried out a study to investigate the interaction between decentralisation and management accounting systems information and their impact on managerial performance. The researcher used the same characteristics of management accounting systems as those used by Chenhall and Morris (1986). He found that the greater degree of decentralisation, the greater is the positive impact of the sophistication of management accounting systems in terms of scope, timelines, integration and the level of aggregation on managerial performance. Gul and Chia (1994) in turn investigated a three-way interaction between decentralisation, PEU and managerial accounting system scope and aggregation. They found that decentralisation and the scope and aggregation of information were associated with higher managerial performance under conditions of high PEU.

Organisational structure based upon mechanistic/organic categories influences the capability of an organisation to successfully adopt and implement an innovation (Damanpour, 1991). In this context, Burns and Stalker (1961) argued that organic organisations (i.e. those more open to individual initiation and discretion) are more likely to experience innovation than are mechanistic organisations. Empirically, Gosselin (1997) investigated the factors that influence the adoption and implementation of activity-based costing system as a new innovation in management accounting. He found that mechanistic structures (vertical differentiation) facilitate the adoption of ABC, also centralisation and formalisation were associated with implementing the ABC system. Mooraj et al. (1999) argued that a decentralised organisation which relies on trust and autonomous decision-making would employ the balanced scorecard in an entirely different way than a centralised organisation which relies on top-down process of instructions and implementation throughout its hierarchy. Recently, Nilsson and Kald (2002) argue that management style in Scandinavia with its decentralised decision making has contributed to the adoption of balanced scorecard. More recently, Baines and Langfield-Smith (2003) found that a change in organisation design, with greater use of team-based structures would result in greater reliance on non-financial management accounting information.

As mentioned earlier, organisation structure is an important variable in understanding management control system design. However, there are few studies that have considered the fit between organic structure and management control system (Chenhall, 2003, p. 146). Thus, the lack of significant relationship between structure and management accounting systems does not confirm that there is no relationship between them. Gordon and Narayanan (1984, p.

35) argued that relatively less clear is the relationship between characteristics of an information system and organisation structure. Thus, this research considers organisation structure as a contingent variable that influence the extent of usage of both performance measurements and the balanced scorecard.

4.7.3 Perceived environmental uncertainty

The environment comprises all the factors external to the organisation. It is defined as all the elements that exist outside the boundary of the organisation and have the potential to affect all or part of the organisation (Daft, 1992). Uncertainty means that decision makers do not have sufficient information about the environmental factors (Daft, 1992). Mintzberg (1979) indicated that the external factors consist of the economic, political, social and technological environments in which the organisation operates. According to Daft (1992), perceived environmental uncertainty (PEU) consists of two main dimensions (see Figure 4.3), the stable-unstable dimension and the simple-complex dimension.

Figure 4.3 Framework for assessing environmental uncertainty. Source: Daft (1992), p. 77

	<p>Simple + Stable = Low Uncertainty</p>	<p>Complex + Stable = Low-Moderate uncertainty</p>
Stable	<ol style="list-style-type: none"> 1. Small number of external elements, and elements are similar 2. Elements remain the same or change slowly 	<ol style="list-style-type: none"> 1. Large number of external elements, and elements are dissimilar 2. Elements remain the same or change slowly
Environmental Change	<p>Simple + Unstable = High-Moderate Uncertainty</p>	<p>Complex + Unstable = High Uncertainty</p>
Unstable	<ol style="list-style-type: none"> 1. Small number of external elements, and elements are similar 2. Elements change frequently and unpredictably 	<ol style="list-style-type: none"> 1. Large number of external elements, and elements are dissimilar 2. Elements change frequently and unpredictably
	Simple	Complex
	Environmental Complexity	

The stable-unstable dimension refers to whether elements in the environment are dynamic, whereas the simple-complex concerns environmental complexity which refers to heterogeneity, or the number and dissimilarity of external elements relevant to an organisation's operations (Daft, 1992). PEU involves the level of change in the environment

that occurs unexpectedly, such as unpredictable shifts in the economy, changes in customer demand, and changing technology and so on (Mintzberg, 1979).

The PEU variable has been widely recognised in the organisational design literature (Burns and Stalker, 1961). This variable has been identified as an important variable in management control system studies because it makes managerial planning and control more difficult according to the unpredictability of the future events (Chenhall and Morris, 1986). The environment of an organisation can be characterised by three dimensions: dynamism, heterogeneity, and hostility. Gordon and Miller (1976) argue that high environmental uncertainty in terms of dynamism and hostility lead to the use of broad scope information (i.e. financial and non-financial). In this context, Govindarajan (1984) argued that financial performance measures alone would not, therefore, be adequate to measure managerial efficiency under uncertain environment. In his study on 58 business units in eight Fortune 500 firms, Govindarajan (1984) reported that business units facing higher levels of environmental uncertainty use a more subjective performance appraisal approach, whereas organisations facing lower environmental uncertainty use a more formula-based performance evaluation approach. In the same vein, Gul (1991) found that PEU requires broad scope, timely, integrated and aggregated information, and the match between PEU and management accounting systems lead to high organisational performance. Several researchers (e.g. Chenhall and Morris, 1986; Gul and Chia, 1994; Cauvin and Bescos, 2002; Drury, 2002) have argued that the greater the PEU the greater the need for more sophisticated management accounting information in terms of it being non-financial and future oriented. Recently, Sohn et al. (2003) found that dynamic and heterogeneous environments have a significant effect on the weighting of the balanced scorecard measures. In general, management accounting research has confirmed that PEU has been associated with a need for a more open, externally focused and non-financial style of management control systems (Chenhall, 2003). On the contrary, Banker et al. (2001) found that companies that use a balanced scorecard face less environmental uncertainty. Moreover, Verbeeten (2004) found that perceived environmental uncertainty has no effect on the use of performance measurement diversity.

Based upon the previous argument and findings, this research considers the perceived environmental uncertainty as a contingent variable influencing the extent of usage of both performance measurements and the balanced scorecard.

4.7.4 Intensity of competition

The degree of competition has been identified in contingency-based research as a major factor influencing an organisation's environment, structure and the characteristics of management control system (Khandawalla, 1972; Simons, 1990; Libby and Waterhouse, 1996). Earlier, Khandawalla (1972) argued that the greater the competition, the greater the need to control costs, and to evaluate whether the departments are operating according to expectations. In this context, Khandawalla (1972) conducted a study to examine the effect of different types of competition on the use of management control systems in manufacturing companies. The researcher used the intensity of price competition, the intensity of market competition and the intensity of competition in product quality and variety as measures for determining the intensity of competition. The results of the study suggest differences among the three types of competition concerning their relationship to the usage of management controls. Price competition appears to have little impact on management control usage, distribution competition appears to have a modest positive impact and product competition seems to have a larger positive effect on the management control usage.

The potential determinant of the use of financial and non-financial performance measures is the organisation's competition in the markets (Hoque et al., 2001). Therefore, many researchers (e.g. Ittner and Larcker, 1998a; Otley, 1999) argue that multiple performance measures (i.e. financial and non-financial) are necessary not only to track the financial performance of the organisation, but non-financial performance measures are also required to track customer satisfaction, innovation and the quality of production. Successful measures in these areas are essential to achieve competitive advantage. Lynch and Cross (1995) indicated that a more dynamic performance measurement system is one that motivates continuous improvement in customer satisfaction, flexibility, and productivity. Bhimani (1994) also argued that the adoption of both financial and non-financial measures is a necessary step for manufacturing companies in order to cope with the intensity of market competition. Kaplan and Norton (1992) argue that the balanced scorecard is more appropriate model under the new realities of competition. Recently, Hoque et al. (2001) proposed in a study that the intensity of competition affects the use of multiple performance measures (i.e. balanced scorecard measures) rather than just financial performance measures. The researchers found that the four perspectives of the balanced scorecard were positively and significantly associated with the intensity of competition. Moreover, the new report "Transforming

Strategic Performance” through the balanced scorecard shows that the fast changing market and increased competition have emerged as key drivers for scorecard adoption (Anonymous, 2001). In the same context, Banker et al. (2001) found that companies that use a balanced scorecard operate in more competitive markets and face more competitive pressures. Thus, this research considers the intensity of competition as a contingent variable that affects the extent of usage of both performance measurements and the balanced scorecard.

4.7.5 Organisation size

The size of an organisation is one of most obvious attributes that has played a role in the development of contingency theory studies (Otley and Wilkinson, 1988). The contingency theory literature suggests that the organisation size may affect the design of organisational structure and the use of management control system. Concerning size measurement, there are several ways of estimating organisation size including profits, sales volume, assets and employees (Chenhall, 2003). Several researchers (e.g. Khandwalla, 1972; Merchant, 1984; Ezzamel, 1990) have argued that as an organisation’s size increases, the management control system tends to be more sophisticated. Among those was Khandwalla (1972), who indicated in his study that organisation size, as measured by sales revenue, was positively associated with the sophistication of control and information systems. Recently, Verbeeten (2004) found that size was positively associated with the use of non-financial performance measures.

In particular, research on the size-innovation issue has shown mixed results. For example, Gosselin (1997) found no statistically significant relationship between organisation size and the decision to adopt ABC. On the contrary, Bjornenak (1997) and Hoque and James (2000) argue that management accounting innovation adoption rates have been much higher in larger organisations. Hoque and James (2000) who investigated the relationship between organisation size, product life-cycle stage, market share and the usage of balanced scorecard measures found that the variables in the regression model explained 19% of the variations in balanced scorecard usage. Size was found to be significant explanatory variable. Recently, Lawson et al. (2003b) found that the rate of usage of scorecard systems was affected by the size of the company. The possible reason for the positive relationship between organisation size and management accounting innovation is that larger organisations have relatively greater access to resources to experiment with the introduction of more sophisticated systems (Drury, 2002). Based on this prior reasoning outlined above, this research considers

organisation size as a contingent variable that affects the extent of usage of both performance measurements and the balanced scorecard.

4.7.6 Manufacturing practices

As mentioned earlier, technology variables in particular were seen as crucial contingent variables to study at organisation levels. Recently, manufacturing practices of just in time production (JIT) and total quality management (TQM) have been adopted by many Japanese and U.S. manufacturers (Banker et al., 1993). These practices have been widely used by companies but until 1993, few empirical studies had been undertaken to examine the extent that organisations change their performance measurements in response to these practices (Euske et al., 1993). Over the past years management control system research has developed to consider the role of advanced technologies such as JIT, TQM and flexible manufacturing as dimensions of context (Chenhall, 2003). In this context, Bhimani (1994) provided evidence that the adoption of TQM and JIT was matched with the usage of non-financial performance measures in UK manufacturing companies. Earlier, Young and Selto (1991) indicated that the new manufacturing practices have some implications for performance measures. They argue that there is a need to consider the technological changes within organisational context. Moreover, Ittner and Larcker (2001) stress that several studies that have investigated the association between new manufacturing practices and performance measurement systems have found a link among these choices. They also emphasised that organisations implementing advanced technologies such as JIT and TQM were associated with the provision of non-financial performance measures. In this context, Baines and Langfield-Smith (2003) found that the increased use of advanced manufacturing technology will result in greater reliance on non-financial management accounting information. The rise of TQM and JIT movements drew attention of managers to the importance of focusing on quality of products and services as a means of maintaining competitive advantage. Therefore, this research considers these new practices in terms of JIT and TQM, and the next subsection illustrates the relationship between these practices and the extent of usage of both performance measurements and the balanced scorecard.

4.7.6.1 Total quality management

In today's global competitive markets, the demand of customers is increasing, as they require improved quality of products and services. A continuous improvement in organisation

activities with a focus on the customer is the main aspect of quality and its management. An important issue related to quality is total quality management (TQM), which is considered to be one of the most important components of advanced management practices. TQM promotes involvement of the entire organisation in continuously improving quality. A study in the UK showed that 20% of the organisations surveyed believed that their TQM programmes had significant impact on performance, further evidence from a survey of 500 US executives showed that 30% believed that their TQM programmes had made a competitive difference (McAdam and Bannister, 2001). Researchers such as (Kaplan, 1983; Chenhall, 1997) argue that the conventional financial performance measures are inappropriate in TQM settings. Therefore, several researchers (e.g. Banker et al., 1993; Perera et al., 1997; Ittner et al., 1997) advocate the use of non-financial performance measures in organisations adopting TQM initiatives. The international quality awards such as the European Foundation for Quality Management and the British Quality Foundation also advocate companies to integrate both financial and non-financial measures in their performance measurement system.

The association between TQM and non-financial performance measures has been reported in several studies. McAdam and Bannister (2001) argued that business performance is linked to TQM implementation. In their case study they concluded that organisations applying TQM should incorporate financial and non-financial performance measures. In the same context, Chenhall (1997) conducted a study that examined the reliance on manufacturing performance measures to evaluate managers' performance. They concluded that such reliance could enhance the profitability of organisations pursuing TQM. The results of the study showed the association between TQM and performance was stronger when using manufacturing performance measures. Attempting to address the empirical research in this area, Ittner and Larcker (2001, p. 378) summarised the related research concerning the advanced manufacturing technologies and the performance measurement systems. In this context, they state:

In general, organizations following advanced manufacturing strategies such as just in time, total quality management and flexible manufacturing are positively associated with the provision of non-financial measures and goals such as defect rates, on-time delivery and machine utilization, as well as greater emphasis on non-financial measures in reward systems. But empirical support for the hypothesized performance benefits from these measurement practices is mixed.

Malmi (2001) found that one of the important reasons to encourage balanced scorecard adoption in Finland is the application of TQM. Recent research, however, conducted by Hoque (2003) indicated that the use of traditional performance measures is not appropriate in TQM settings because quality is driven by non-financial factors such as product design and on-time delivery. Therefore, non-financial performance measures must supplement financial measures in providing support for TQM. In this vein, Hoque (2003) recommended that using the balanced scorecard for supplementing financial with non-financial information is supported by the use of TQM.

4.7.6.2 Just in time manufacturing approaches

Just in time manufacturing approaches (JIT) are a Japanese-developed manufacturing philosophy emphasising excellence through the continuous elimination of waste and improvement in productivity (Fullerton and McWatters, 2002). According to Dale et al. (1997), the aim of JIT is to eliminate the wastefulness or non-value added aspects, which are excess production, waiting, conveyance, motion, the process itself, inventory and defects. JIT manufacturing approaches are expected to reduce manufacturing costs continuously through better quality, lower inventory and shorter lead times. This system is a first step to implement more advanced manufacturing technologies such as computer-integrated manufacturing in which the entire organisation is highly automated (Young and Selto, 1991).

Upton (1998) indicates that performance measurement is argued to be a critical aspect of management accounting systems within a JIT environment. Therefore, some studies have investigated the role of non-financial performance measures in JIT settings. Earlier, Banker et al. (1993) found that JIT, quality and teamwork were associated with the provision of non-financial performance measures. Upton (1998) carried out a survey to examine the use of performance measurement systems in organisations implementing JIT. The argument raised by Upton (1998) is that JIT organisations are expected to use non-financial measures to a greater extent than non-JIT organisations, and this greater use of non-financial measures is correlated with organisation performance. The findings of the study showed that the use of non-financial measures was significantly greater for JIT organisations than for non-JIT organisations, and organisation performance was marginally higher in JIT organisations than non-JIT organisations.

Recently, Fullerton and McWatters (2002) conducted a survey to examine whether the use of non-financial performance measures (such as bottom-up measures, product quality and vendor quality), as well as incentive systems of employee empowerment and compensation rewards for quality production, were related to the degree of JIT practices implemented. The study found a significant statistical relationship between the implementation of JIT and the adoption of non-financial performance measures and incentive systems within the management accounting system. Clinton and Hsu (1997) have also argued that the balanced scorecard approach will benefit organisations and their managers who analyse and control operations in a just in time manner.

4.8 Summary

This chapter has presented a brief discussion on the contingency theory of organisation structure and a literature review on the relationship between the contingency theory framework and the aspects of financial and non-financial performance measurements. The general overview emphasises that the choice of performance measurement systems depends upon several internal and external factors. The contingency approach to management accounting is based on a proposition that there is no universally appropriate accounting system which applies to all organisations in all circumstances (Otley, 1980). Therefore, the contingency-based research has a long tradition in the study of management control systems through explaining the effectiveness of these systems by examining the nature of the contextual variables (e.g. environment, structure and strategy).

This chapter has also discussed a group of contingent variables that have been considered to affect the extent of usage of both performance measurements and the balanced scorecard. With regards to the broad number of contingent variables, this research, has identified and described a selection of contingent variables based upon the literature review. These variables are business strategy, organisational structure, perceived environmental uncertainty, organisation size, intensity of competition, total quality management and just in time manufacturing approaches. They have been briefly discussed in this chapter in order to build and support the research theoretical model. The research theoretical model and hypotheses are presented in the next chapter.

Chapter 5

Research theoretical model and hypotheses

5.1	Introduction.....	5-3
5.2	Building the research theoretical model.....	5-3
	5.2.1 Justification for building the first research theoretical model.....	5-4
	5.2.2 Justification for building the second research theoretical model.....	5-7
5.3	Research aim and objectives.....	5-11
5.4	Operational definition of the research variables.....	5-12
	5.4.1 Operationalising the contingent variables.....	5-13
	5.4.1.1 Business strategy.....	5-13
	5.4.1.2 Organisational structure.....	5-14
	5.4.1.3 Perceived environmental uncertainty.....	5-14
	5.4.1.4 Intensity of competition.....	5-15
	5.4.1.5 Organisation size.....	5-16
	5.4.1.6 Total quality management.....	5-16
	5.4.1.7 Just in time manufacturing approaches.....	5-16
	5.4.2 Operationalising the extent of performance measurement diversity usage (PMD).....	5-17
	5.4.3 Operationalising the extent of balanced scorecard usage (BSCUSE).....	5-19
	5.4.4 Operationalising organisational effectiveness.....	5-21
5.5	Research variables and hypotheses formulation.....	5-22
	5.5.1 Hypotheses relating to factors influencing the extent of performance measurement diversity usage (PMD).....	5-22
	5.5.1.1 Business strategy and the extent of PMD usage.....	5-23
	5.5.1.2 Organisational structure and the extent of PMD usage.....	5-24
	5.5.1.3 Perceived environmental uncertainty and the extent of PMD usage.....	5-24
	5.5.1.4 Intensity of competition and the extent of PMD usage.....	5-25
	5.5.1.5 Organisation size and the extent of PMD usage.....	5-25
	5.5.1.6 Total quality management and the extent of PMD usage....	5-26
	5.5.1.7 Just in time manufacturing approaches and the extent of PMD usage.....	5-26

5.5.2	Hypotheses relating to the effectiveness of PMD usage.....	5-27
5.5.3	Hypotheses relating to factors influencing the extent of balanced scorecard usage.....	5-28
5.5.3.1	Business strategy and the extent of balanced scorecard usage.....	5-28
5.5.3.2	Organisational structure and the extent of balanced scorecard usage.....	5-29
5.5.3.3	Perceived environmental uncertainty and the extent of balanced scorecard usage.....	5-30
5.5.3.4	Intensity of competition and the extent of balanced scorecard usage.....	5-30
5.5.3.5	Organisation size and the extent of balanced scorecard usage.....	5-30
5.5.3.6	Total quality management and the extent of balanced scorecard usage.....	5-31
5.5.3.7	Just in time manufacturing approaches and the extent of balanced scorecard usage.....	5-31
5.6	Summary.....	5-32

Chapter 5

Research theoretical model and hypotheses

5.1 Introduction

The literature review presented in the previous chapters provides some support for the contingent relationships between business strategy, organisational structure, perceived environmental uncertainty, intensity of competition, organisation size, manufacturing practices and the extent of usage of both performance measurements and the balanced scorecard. However, these relationships are still not clear for the balanced scorecard due to the limited research in this area. Thus, the main aim of this chapter is to provide explanations and clarifications for building the research theoretical model and developing the hypotheses. This is primarily based on the key findings and recommendations from the literature review of the performance measurement systems, the balanced scorecard and the contingency theory research. This chapter is structured as follows: Section 5.2 discusses building the research theoretical model based on the literature review. Section 5.3 represents the research objectives. Section 5.4 introduces the operational definition for the research variables in the model. The suggested relations between research variables and the formulations of the hypotheses are given in section 5.5. Finally, section 5.6 provides a summary of the chapter.

5.2 Building the research theoretical model

Three areas of research are important for this study. First, prior literature on performance measurement systems provides evidence on the need to incorporate both financial and non-financial performance measurements. Second, prior balanced scorecard research suggests various issues relating to how companies are implementing the balanced scorecard approach. Third, prior research suggests several contingent variables relating to the extent of usage of performance measurements and the balanced scorecard. These studies provided the motivation for developing the research theoretical model and the research hypotheses for this study. The theoretical model of this research includes interrelated parts, which are contingent variables, the extent of performance measurement diversity usage (i.e. financial and non-financial), the extent of balanced scorecard usage and organisational effectiveness. In order to present the relationships between the aforementioned parts, the decision was made to divide the overall research theoretical model into two models.

5.2.1 Justification for building the first research theoretical model

Figure 5.1 explains the first research theoretical model, which is the conceptual framework of this research. The figure shows the relationship between the three parts of the model. The first part is concerned with seven contingent variables which are business strategy, organisational structure, perceived environmental uncertainty, intensity of competition, organisation size, total quality management and just in time manufacturing approaches. The second part is concerned with the extent of usage of performance measurement diversity. The third part is concerned with organisational effectiveness.

Figure 5.1 The first research theoretical model

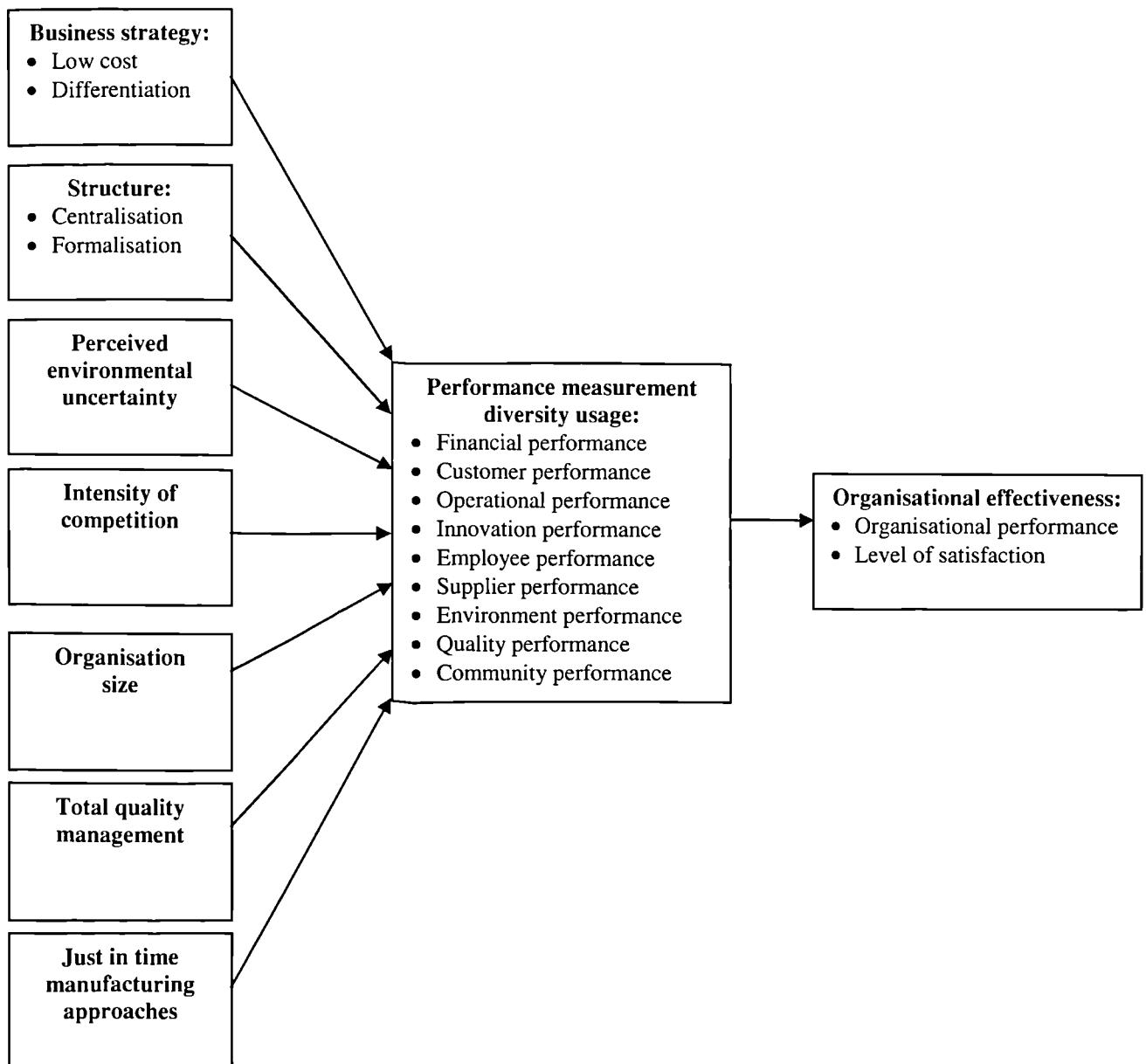

The arguments and justifications that explain the rationale of constructing the first research theoretical model are primarily forwarded based on previous theoretical and empirical research in performance measurement systems and through the theoretical gaps that emerged from the literature review in order to achieve the first three research objectives listed in section 5.3.

A growing body of literature in management accounting concentrates on studying performance measurement. This is supported by the large number of articles that investigate the role and importance of performance measurement. The examination of the performance measurement systems literature discussed in Chapter 2 showed that many management accounting scholars (e.g. Kaplan, 1984; Eccles, 1991; Kaplan and Norton, 1992; Neely et al., 1995; Otley, 1999; Norreklit, 2000; Malina and Selto, 2001; Laitinen, 2002; Drury, 2002) criticise the idea of relying solely on financial performance measurements. Incorporating both financial and non-financial performance measurements is considered to present an essential part of management information system. A substantial body of literature in management accounting (e.g. Kaplan, 1983; Keegan et al., 1989; Maskell, 1989; Lynch and Cross, 1995; Ittner et al., 1997; Ittner and Larcker, 1998a; Neely, 1999; Hughes, 2000) also emphasises the need for more strategic non-financial information. Thus, one of the most important arguments in this research is that management accounting researchers (e.g. Nanni, et al., 1992; Kaplan and Norton, 1996a; Hoque and James, 2000; Otley, 2001; Giannetti, et al., 2002) advocate using performance measurement diversity in order to provide managers with appropriate financial and non-financial information about the overall organisation situation. Thus, it can be concluded that many research studies have analysed the use and effect of non-financial performance measurements in organisations. However, several researchers recommend further research on the implications of non-financial performance measurements. For instance, Fisher (1998, p. 62) states that:

Most accounting research on control has focused on financial control systems (i.e. budgeting and standard cost systems). Future research should incorporate non-financial performance measures.

Recently, Sandt et al. (2001, p. 13) state that:

It was assumed that apart from balance and linkage of performance measures, no further context factors or design parameters have a significant impact on the conceptual use of and satisfaction with performance measurement. In future papers, these premises should be examined.

Vaivio (1999) suggests a number of outstanding areas and gaps needed to be filled. Thus, he suggested further research agenda, which are worthy of investigation. Some of these include:

- There is a need for more investigation of non-financial performance measures alongside the examination of the traditional financial measures.
- How the non-financial performance measures became integrated with the management process.
- Non-financial performance measures may have a more active role to play as a focusing interactive control that serves the discovery of strategy's elements.

A contingency approach to performance measurement has been widely used in management accounting research (Gordon and Narayanan, 1984; Sim and Killough, 1998). Contingent variables have been mainly used in previous research to explain observed different characteristics of management control systems. This stream of research, however, has two limitations. First, it considered only one or a few variables. Second, it did not pay attention to whether the hypothesised fit between the contingent variables and certain characteristics of management control systems also results in better organisational and managerial performance (Tillema, 2005). Several researchers (e.g. Francis and Minchington, 2000) suggest the need to focus on performance measurement diversity and that this may well be contingent upon organisational circumstances in UK organisations. In this context, Hussain and Gunasekaran (2002, p. 532) state that:

The issue of non-financial performance and its measurement is receiving increasing emphasis in the manufacturing industry, and it would be of interest to examine how different factors affect non-financial performance measures in this sector.

Considerable attention has been given to the choice of performance measures. Thus, the choice of performance measures is a function of the organisation's competitive environment, strategy and organisational design (Ittner and Larcker, 2001, p. 379). In the same vein, Speckbacher et al. (2003, p. 374) state that:

There are several contingent variables that may affect the design and the effectiveness of strategic performance measurement systems. Beside size, there are several important contextual factors such as environment, technology, structure, and strategy.

The above argument was also supported by several researchers (e.g. Maltz et al., 2003; Said et al., 2003). In addition, the literature on contingency theory investigates the relationship between contingent variables, the use of control and performance measurement systems and in turn organisational effectiveness. The study of organisational effectiveness has been at the core of management accounting research. However, real issues still exist concerning the definition and measurement of organisational effectiveness. Several researchers (e.g. Lingle and Schiemann, 1996; Hoque and James, 2000) argue that companies achieve higher performance when they use a diversity of financial and non-financial performance measurements. Recently, Maltz et al. (2003) indicate that little empirical testing has been performed to test and validate the organisational effectiveness.

Based on the aforementioned arguments, the present research focuses on investigating the extent of usage of performance measurement diversity. Moreover, the research seeks to explore the relationship between several contingent variables (business strategy, organisational structure, perceived environmental uncertainty, intensity of competition, organisation size, total quality management and just in time manufacturing approaches) and the extent of usage of performance measurement diversity in UK manufacturing companies.

Finally, the research seeks to investigate the relationship between the contingent variables, the extent of performance measurement diversity usage and organisational effectiveness. The justifications for targeting UK manufacturing companies are discussed in Chapter 6.

5.2.2 Justification for building the second research theoretical model

Figure 5.2 explains the second research theoretical model. The figure shows the relationship between two parts of the model. The first part is concerned with the same seven contingent variables that were included in the performance measurement diversity model specified in Figure 5.1. The second part is concerned with the extent of usage of balanced scorecard. The arguments and justifications that explain the rationale of constructing the second research theoretical model are primarily forwarded based on previous theoretical and empirical balanced scorecard research, and through the theoretical gaps that emerged from the literature review in order to achieve the last two research objectives listed in section 5.3.

Figure 5.2 The second research theoretical model

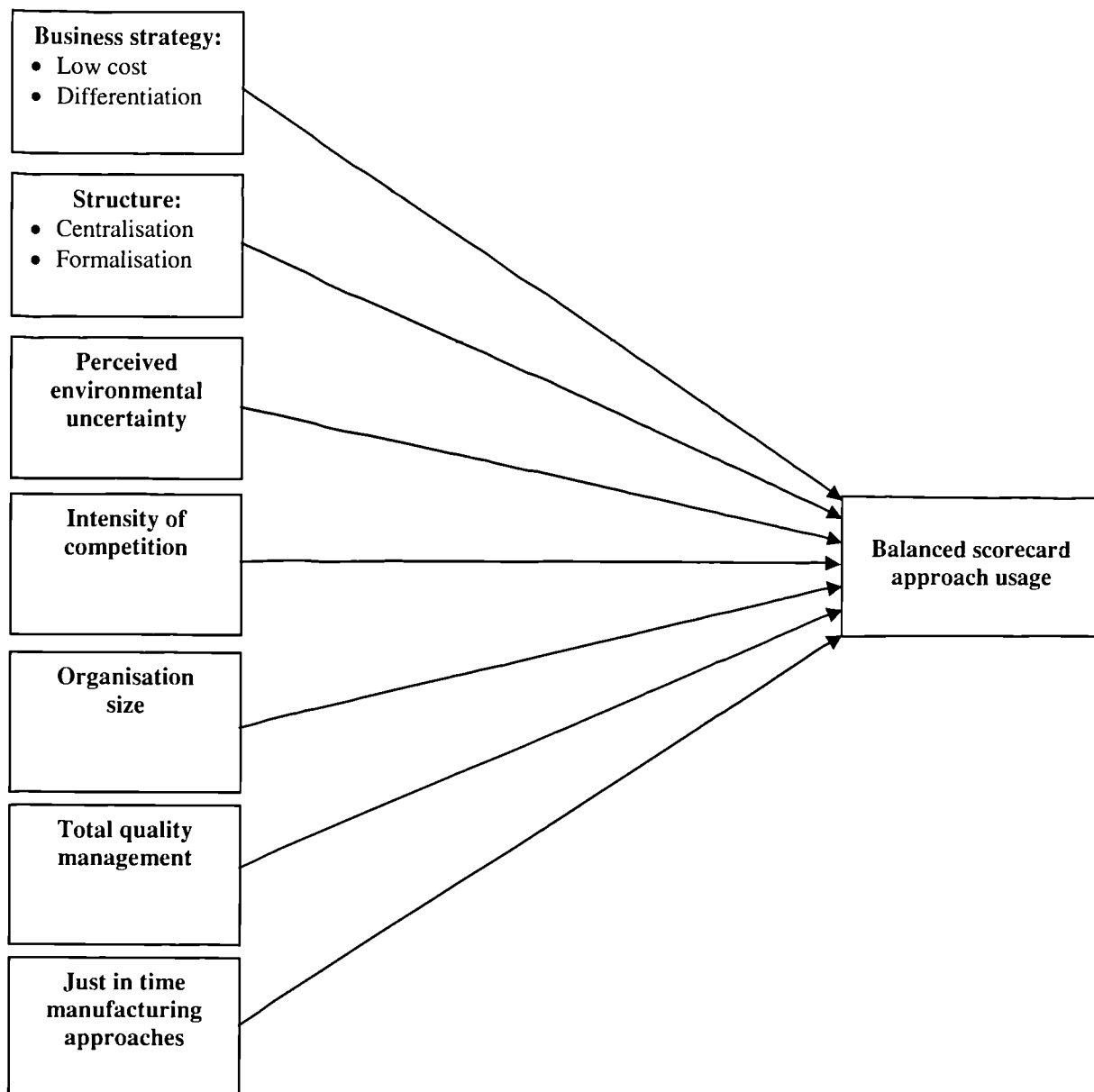

The examination of the performance measurement framework literature discussed in Chapter 2 concluded that the balanced scorecard is the most popular framework in management accounting and that it has attracted a considerable interest among researchers and companies (Chenhall and Langfield-Smith, 1998a; Mooraj et al., 1999; Norreklit, 2000; Ahn, 2001; Malmi, 2001; Braam et al., 2002; Leaby and Wentzel, 2002; Sandstrom and Toivanen, 2002; Olson and Slater, 2002). The literature on the balanced scorecard discussed in Chapter 3 concluded that the assumptions of this approach have attracted a lot of debate from researchers, particularly the cause-and-effect assumption (e.g. Butler et al., 1997; Norreklit, 2000; Malmi, 2001; Malina and Selto, 2001). In addition, recent literature (e.g. Letza, 1996; Silk, 1998; Chenhall and Langfield-Smith, 1998a; Pere, 1999; Kald and Nilsson, 2000;

Giannetti et al., 2002; Braam et al., 2002; Guenther and Gruening, 2002) showed that the level of adoption and implementation of this approach in different countries. The level of implementation between companies, however, is different and needs further investigation (Olve et al., 1999; Malmi, 2001; Southern, 2002; Oliveras and Amat, 2002). Therefore, researchers (e.g. Ittner and Larcker, 1998a; Malmi, 2001; Nielsen and Sorensen, 2003; Chenhall, 2003) suggest conducting more research to investigate how companies in different contexts apply the balanced scorecard. In addition, the following are some recommendations identified in the literature for further balanced scorecard research:

- There is a need to conduct systematic comparative research in order to relate the value of the Balanced Scorecard, and the value of specific elements of it, to the context of application (Southern, 2002, p. 401).
- However, the interpretative viability of the concept means that it remains to be seen how, and to what extent, the BSC actually will be used (Braam et al., 2002, p. 21).
- Future studies will need to devise improved methods for eliciting what firms mean by a balanced scorecard and how this information is actually being used (Ittner, Larcker and Randall, 2003, p. 739).
- Little empirical work has focused on evaluating the contribution that measures reflecting the balanced scorecard categories make to performance assessed in either financial or non-financial terms. Undertaking such work would seem essential (Dunk, 2003, p. 2).
- The balanced scorecard framework provides constructs for multiple measures and overcoming the limitations of single measures. There is no clear provision for very long-term measures; the distinction between means and ends is not well defined, and the model probably needs additional empirical validation (Maltz et al., 2003, p. 190).
- Consequently, future research on scorecard adoption and performance consequences must move beyond the measurement of these attributes to encompass the entire implementation process (Ittner, Larcker and Meyer, 2003, p. 754).
- One of the most powerful tools designed in recent years for implementing strategy and helping managers in their operational decisions is the BSC. But although practitioners praise its usefulness, academics are still looking for the best way of understanding and using it. What is more important is to understand properly the concept of what a BSC is and how it works (Marcela et al., 2003, p. 14).

The literature review of the balanced scorecard and the contingency theory has revealed that there are very few empirical studies that have investigated the relationship between the contingent variables and the balanced scorecard (Malmi, 2001; Olsen and Slater, 2002; Chenhall, 2003). In addition, the following are some recommendations identified in the literature for further balanced scorecard research drawing off contingency theory theoretical framework:

- Research can also identify the key success factors that make the balanced scorecard a successful tool for organizations. It is likely that the key success factors are contingent on a number of organizational facets (Atkinson et al., 1997, p. 94).
- Future research can make a significant contribution by providing evidence on the contingency variables affecting the predictive ability, adoption and performance consequences of various non-financial measures and the balanced scorecard (Ittner and Larcker, 1998a, p. 224).
- The balanced scorecard is also proving to be a very popular tool, but how are organizations actually using it in practice, and what are the contextual factors that affect an organization's likely interest in such matters (Otley, 1999, p. 380).
- Researchers should study further how BSCs are actually used in practice. In fact, further research will determine whether we can better explain the various uses of the BSC by looking at organizational characteristics (Malmi, 2001, p. 216).
- However, there is very little published contingency work on balanced scorecard (Chenhall, 2003, p. 4).
- In the future there would be a need to construct and carry out several types of surveys, for example concerning the exact factors regarding usage and benefits of BSC (Nielsen and Sorensen, 2003, p. 16).
- Further, research should explore how the benefits of the BSC are affected by different industry characteristics, including type of industry, level of competition, and type of strategy (Davis and Albright, 2004, p. 151-152).

The literature on the balanced scorecard describes a variety of purposes of balanced scorecard implementation and benefits for users (e.g. Kaplan and Norton, 1996c; Norreklit, 2000; Malmi, 2001). However, Sandt et al. (2001) noted that there is little empirical evidence for the claim that the usage of the balanced scorecard leads to a higher degree of user satisfaction. In the same context, Bremser and White (2000) indicated that there is no definite empirical evidence to show that using the balanced scorecard leads to superior performance. Kasperskaya and Oliveras (2003) argued that academics and practitioners hold opposite view on the effectiveness of the balanced scorecard approach. Several case studies (e.g. Malina and Selto, 2001; Davis and Albright, 2004) provided evidence of a relationship between using a balanced scorecard and improvements in financial performance. However, Yeniyurt (2003, p. 136) indicated that there is only one cross-sectional survey that examines the relationship between the contextual factors, balanced scorecard usage and organisational performance (Hoque and James, 2000), reporting that balanced scorecard usage is associated with improved performance. In contrast, Ittner, Larcker and Randall (2003) provided contradictory evidence to the previous studies by finding a negative association between balanced scorecard usage and financial performance.

An explanation for these inconsistent findings may be the lack of control in these studies for differences in the implementation and the actual way in which the balanced scorecard is used (Braam and Nijssen, 2004b, p. 340). The balanced scorecard is used in different ways involving many different functional areas and indicators. Different ways of implementing and using the balanced scorecard may have different effects on organisational effectiveness (Malmi, 2001; Speckbacher et al., 2003). Therefore, the decision was made to exclude organisational effectiveness from the second research theoretical model¹.

Based on the aforementioned arguments, the present research aims to investigate the extent of usage of the balanced scorecard approach. This research is also interested in exploring how UK manufacturing companies apply the balanced scorecard. Moreover, the research seeks to explore the relationship between several contingent variables outlined in Figure 5.2 and the extent of usage of the balanced scorecard in UK manufacturing companies.

5.3 Research aim and objectives

Building on the discussion in Chapters 2 - 4, this research aims to investigate the current knowledge relating to the effective usage of performance measurement diversity and the balanced scorecard. This is achieved by extending previous studies along several dimensions:

- Examining a broader set of performance measurements relating to their importance to long-term organisational success and their corresponding use in performance measurements and evaluation purposes (i.e. managerial performance evaluation, financial rewarding, and identification of improvement opportunities and development of action plans), setting strategic goals and quality of these performance measurements.
- Investigating how manufacturing companies are dealing with the balanced scorecard approach.
- Incorporating contingency theory by examining the relationships between multiple contingent variables and the extent of usage of both performance measurement diversity and the balanced scorecard approach.
- Assessing the performance implications of performance measurement diversity usage based on measures of organisational effectiveness.

¹ Furthermore, it was inappropriate to use structural equation modelling which is the appropriate statistical tool for incorporating the fit between the contingent variables, the balanced scorecard and organisational effectiveness (see Chapter 8, section 8.4 for an explanation of why structural equation modelling could not be applied to the second research theoretical model).

In particular, the current research aims to achieve the following objectives:

1. To ascertain the extent of usage of broader set of financial and non-financial performance measures and their implications in the manufacturing companies in UK.
2. To determine the relationship between various contingent variables and the extent of performance measurement diversity usage.
3. To examine the relationship between the contingent variables, the extent of performance measurement diversity usage and organisational effectiveness.
4. To ascertain how UK manufacturing companies apply the balanced scorecard approach.
5. To determine the relationship between various contingent variables and the extent of balanced scorecard usage.

Hopefully, this research can contribute to shifting the discussion from the question of whether to introduce the balanced scorecard approach or not, to an advanced analysis of the effect of several contingent variables on the extent of usage of the balanced scorecard (see Section 5.2 for an explanation for not pursuing organisational effectiveness with the balanced scorecard approach).

5.4 Operational definition of the research variables

Research variables are conceptual definitions which logically precede operational definitions that enable facts to be measured quantitatively (Easterby-Smith et al., 2002). In order to derive an operational definition for each variable, the literature on performance measurement systems, the balanced scorecard and contingency theory has been reviewed. The review revealed that there are few empirical studies that have investigated the relationship between multiple contingent variables and the extent of usage of both performance measurement diversity and the balanced scorecard. Moreover, it can be noted that there has been no one research instrument in the literature that can be used to provide a comprehensive operational definition for the variables used in this research. However, the literature review that has been carried out in the previous chapters has shown a very rich source of material for deriving operational definitions of the research variables. Therefore, the next sub-sections show the construction of the operational definitions of the variables that are included in the research theoretical models.

5.4.1 Operationalising the contingent variables

This part of the research theoretical model includes the contingent variables that might affect the extent of usage of both performance measurement diversity and the balanced scorecard. As the measurement of contingency variables remains controversial (Larcker, 1981), the instruments used in this research were based on the contingency theory and management control literature. Thus, the conceptual definitions of these contingent variables are discussed briefly in the following sub-sections.

5.4.1.1 Business strategy

As indicated in Chapter 4, there are different classifications of business strategy. Strategy has been defined and measured in many ways in the contingency theory management control system research. Thus, Langfield-Smith's (1997) study asserts that there is a level of consistency between the organisational and control characteristics of defender and cost leader, and a prospector and differentiator. According to Olson and Slater (2002), the Porter (1980, 1985) and Miles and Snow (1978) typologies of strategy are the frameworks that have most often been shown to effectively represent managerial choices. However, the present research adopts Porter's strategies for a number of reasons:

1. Porter's strategic framework is academically well accepted (Govindarajan, 1988).
2. The typology of prospector and defender has a broad scope, while differentiation and cost leadership is much narrower (Langfield-Smith, 1997).
3. Several studies suggest that there is a level of consistency between the organisational and control characteristics of defender and cost leadership, and a prospector and differentiation (Langfield-Smith, 1997).
4. Porter's generic strategies combination implied that organisations should build their performance measurement system upon financial and non-financial measures (Cauvin and Bescos, 2002).
5. According to Kaplan and Norton (1996c), the balanced scorecard relies on the concept of strategy developed in Porter (1980, 1985).

Porter (1980; 1985) identified two generic ways (i.e. differentiation and low cost) in which a business can gain and sustain competitive advantage over other businesses in the same industry. Companies pursuing a low cost strategy do not imply that they can ignore quality

features or other bases for differentiation. Similarly, companies pursuing a differentiation strategy cannot ignore costs (Govindarajan, 1988). In order to develop an effective competitive strategy, this variable included two dimensions: low cost and differentiation. The dimensions of business strategy were operationalised in this study as:

- Low cost strategy: By emphasising the need to incur the lowest costs in an industry. This strategy requires construction of efficient-scale facilities, vigorous pursuit of cost reductions from experience, tight cost and overhead control, avoidance of marginal customer accounts and cost minimisation in different areas such as R&D (Porter, 1980).
- Differentiation strategy: By seeking uniqueness in the industry along dimensions that are widely valued by buyers (Porter, 1980).

5.4.1.2 Organisational structure

Organisation structure was viewed in terms of Burns and Stalker's (1961) notion of mechanistic and organic. These continuums have been widely used in contingency theory management control systems research (e.g. Khandawalla, 1972; Gordon and Narayanan, 1984) and in management accounting innovation diffusion (e.g. Damanpour, 1991; Gosselin, 1997). Based on the argument developed earlier in Chapter 4, there are several dimensions to measure organisation structure. Centralisation and formalisation are two organisational dimensions that are often used to operationalise the organic-mechanistic structure. These two dimensions were selected because they represent major dimensions of organisational structure (Waterhouse and Tiessen, 1978; Mintzberg, 1979). Furthermore, these dimensions have previously been employed in research design investigating organisational innovation (Zmud, 1982). Centralisation represents the concentration of decision-making authority at a specific level in the hierarchy. Formalisation represents the extent that rules governing behaviour are precisely and explicitly formulated and the extent that procedures and roles are detailed (Al-Dahiyat, 2003).

5.4.1.3 Perceived environmental uncertainty

There are two streams of accounting studies concerning perceived environmental uncertainty (PEU), one stream of studies is based on Duncan's (1972) work and the other stream is based on Khandawalla (1972) and Miles and Snow (1978). Duncan (1972) operationalised PEU as lack of information, not knowing how to respond and not knowing the outcome of the

decision. Also, this stream of studies is related to internal factors and does not restrict the term environment to external factors (Tymon et al., 1998).

According to Tymon et al. (1998), the stream of studies of Khandawalla (1972) and Miles and Snow (1978) include an adequate operationalisation of PEU, and these studies questioned subjects about the predictability of the external environment. Earlier, Gordon and Narayanan (1984, p. 35) indicated that considerable effort has been geared toward refining the notion of environmental uncertainty. They also argued that considerable debate in organisation theory has revolved around the question of whether in contingency formulation, uncertainty as a predictor of organisational characteristics, refers to an objective property of the environment or a property subjectively interpreted by key decision makers. For example, Lawrence and Lorsch (1967) consider PEU to be a perception (i.e. subjective interpretation) by key decision makers. However, according to Tosi et al. (1973), attempts at correlating perceptions of PEU with actual environmental uncertainty did not prove successful (quoted in Gordon and Narayanan, 1984, p. 35). In accounting, Otley (1987) argued that the major underlying factor affecting accounting information system design is environmental unpredictability (quoted in Tymon et al., 1998, p. 28). According to the recommendations made by Tymon et al. (1998), PEU should be operationalised to represent top managers' perceptions of the level of uncertainty regarding the external environment (e.g. competition, raw materials, regulation, technology).

Therefore, the dimension of PEU was operationalised in this research as the level of unpredictability and change. Examples include changing technology, unexpected changes in customers' demand, competitors' actions (Miles and Snow, 1978; Govindarajan, 1984). Therefore, when the rate of change that occurs unpredictability is low, perceived environmental uncertainty is considered low, and when the rate of change that occurs unpredictability is high, perceived environmental uncertainty is considered high.

5.4.1.4 Intensity of competition

To recall from the discussion in Chapter 4, sub-section 4.7.4, Khandawalla (1972) considered price, product, and marketing or distribution channels as factors comprising the market competition. Other studies (e.g. Gordon and Narayanan, 1984; Libby and Waterhouse, 1996; Hoque et al., 2001) have extended Khandawalla (1972) factors by incorporating other

competitive dimensions such as new entrants in the market and competitors' strategies. Based on these studies, the dimensions of intensity of competition were operationalised in this research as price, new product development, marketing or distribution channels, market share, competitors' actions and number of competitors.

5.4.1.5 Organisation size

Following the argument developed in Chapter 4, sub-section 4.7.5, organisational size has been widely used as a contingent variable in contingency theory studies. The previous studies (e.g. Bruns and Waterhouse, 1975; Merchant, 1981; 1984; Ezzamel, 1990; Libby and Waterhouse, 1996; Hoque and James, 2000) have measured organisation size using the following dimensions: number of employees, sales turnover and total assets. This research measures organisation size by the annual sales turnover.

5.4.1.6 Total quality management

The adoption of new manufacturing practices is a response to the increasing level of global competition. It was emphasised in sub-section 4.7.6.1 that the usage of quality initiatives was related to the use of non-financial performance measures (Ittner and Larcker, 2001; Baines and Langfield-Smith, 2003). The previous studies (e.g. Banker et al., 1993) measured total quality management by the involvement of the entire business units in continuously improving quality. Thus, in this research the conceptual definition of total quality management implementation focuses on aspects of quality initiatives. Examples include quality incentives, quality of processes and continuous quality improvement.

5.4.1.7 Just in time manufacturing approaches

It was emphasised in sub-section 4.7.6.2 that the usage of just in time manufacturing approaches were related to the use of non-financial performance measurements (Upton, 1998; Fullerton and McWatters, 2002). The previous studies (e.g. Banker et al., 1993; Krumwiede, 1998) defined just in time by the degree of implementation. Thus, in this research the conceptual definition of just in time manufacturing approaches focuses on production practices. Examples include compliance to production schedules and learning multiple skills.

5.4.2 Operationalising the extent of performance measurement diversity usage (PMD)

Extensive academic research concerning the implications and practices of non-financial performance measurements were identified in Chapter 2 and resulted in several notions and boundaries. A stream of research (e.g. Anderson et al., 1994; Nagar and Rajan, 2001; Maines et al., 2002) provided evidence that the use of non-financial performance measurements can be leading indicators of financial performance. Consistent with this evidence, Guenther and Gruening (2002) found that the structure of performance measurement is strongly determined by the relevance for companies' long-term success. Recently, Ittner, Larcker and Randall (2003) argued that supplementing financial measurements with a diversity of non-financial measures are believed to provide relevant information on an organisation's strategic success.

Another stream of research (e.g. Rapport, 1999; Ittner, Larcker and Meyer, 2003) has argued that non-financial performance measurements should be linked to the financial reward system. Moreover, researchers (e.g. Chenhall and Morris, 1986; Otley, 1999) have argued that using non-financial performance measurements should be linked to target settings to evaluate managerial performance. In this context, Ittner and Larcker (2001) indicated that prior studies have ignored target setting as a key aspect of performance measurement. However, the use of non-financial measurements in managerial performance evaluation has been on the increase (Ittner et al., 1997). Other researchers (e.g. Chenhall and Morris, 1986; Ittner, Larcker and Randall, 2003) argued that non-financial performance indicators should provide information that reflect the attributes of these indicators. Moreover, prior empirical studies have overlooked the quality of information used for management purposes (Ittner and Larcker, 2001). The choice of performance measurements is one of the most important challenges facing companies and these measures play a key role in developing strategic plans, evaluating managerial performance and compensating managers (Ittner and Larcker, 1998a). Recently, Banker et al. (2004) indicated that combining financial and non-financial performance measurements led to improved decision making and problem solving.

Consequently, organisations are still lacking the connection between performance measurements and subsequent management action, and the need to look beyond measurement to the use of information in decision-making and control (Otley, 2001, p. 249-250). Although much is being written about non-financial performance measurements, very little is known about actual current practices (Stivers et al., 1998, p. 44). However, a main

issue is to investigate whether performance measurement can be used for both improved decision-making and control.

Supplementing traditional performance measurements with a diversity of non-financial performance measurements is an essential approach of strategic performance measurement. Determining the appropriate set of performance measurements is still one of the most critical challenges facing organisations (Ittner and Larcker, 1998b). In this context, Lingle and Schiemann (1996) argue that organisations have to determine what they want to measure and measure it properly. In the same vein, Schiemann and Lingle (1999, p. 8) state that:

For us, measuring the “right things” entails measuring results in the six performance areas that are key strategic success. And when we use the term “strategic measurement” we mean measurement focused on these six perspectives or areas of performance (quoted in Ittner, Larcker and Randall, 2003, p. 717-718).

Several researchers (e.g. Stivers et al., 1998; Hoque et al., 2001) draw on the performance measurement diversity approach in their empirical studies. Thus, this study operationalises the extent of performance measurement diversity usage by using nine performance categories. These categories include: financial, customer, operational, innovation, employee, supplier, environment, quality and community. These categories are drawn from the literature review of performance measurement systems and the balanced scorecard (e.g. Kaplan and Norton, 1996c; Lingle and Schiemann, 1996; Hoque and James, 2000; Ittner, Larcker and Randall, 2003). However, this research examines the extent to which performance measurement categories are important drivers to the firms’ long-term organisational success. This research also extends prior research by examining the following uses of performance measurement diversity: (1) the extent to which these indicators are used to evaluate managerial performance, (2) the extent to which these indicators are linked to the financial reward system, (3) the extent to which these indicators are used to identify problems and improvement opportunities and developing action plans, (4) the extent to which these indicators explain the information reflected in it, and finally, (5) the extent to which strategic goals are set for these indicators. Thus, the extent of performance measurement diversity usage (PMD) is the average standardised rating for each of the nine performance categories (financial and non-financial) across all uses (for a further elaboration of this measure see Chapter 8, sub-section 8.2.8).

5.4.3 Operationalising the extent of balanced scorecard usage (BSCUSE)

A great deal of literature on the balanced scorecard shows that this approach was developed since its introduction from a combination of financial and non-financial performance measures into a multidimensional framework for strategic performance measurement that describes strategy by using cause-and-effect relationships (Kaplan and Norton, 2001c). Many researchers (e.g. Norreklit, 2000; Malmi, 2001) argue that there is no common way to judge whether these competitive strategies are reflected in the balanced scorecard measures. Moreover, what organisations seem to do in practice is to divide strategy into manageable pieces. This should not depend on how organisation defines its strategy, or how it derives measures from it (Malmi, 2001). In addition, there are various interpretations on how to derive measures from strategy, even in the writings of Kaplan and Norton (Malmi, 2001, p. 216). Based on their findings, Braam and Nijssen (2004b) suggest that the translation of strategy into operational measures is a complicated and dynamic process. Also, it should be noted that performance measurement systems without cause-and-effect relationships may also qualify as balanced scorecards. In this context, Speckbacher et al. (2003) found that many companies do not see cause-and-effect relationships as a prerequisite for a balanced scorecard-based reward system.

Kaplan and Norton (1996c; 2001c) stress that companies can employ more than the original four perspectives, this was supported by several researchers (e.g. Neely et al., 1995; Olve et al., 1999; Speckbacher et al., 2003; Nielsen and Sorensen, 2003). As indicated in Chapter 3, there are several types of balanced scorecard approaches, whereas in theory and practice, different terms exist on the definition and the characteristics of the balanced scorecard (Olve et al., 1999; Malmi, 2001). Furthermore, no reliable statement can be made about the degree to which balanced scorecard has been implemented (Speckbacher et al., 2003). Also, it should be noted that many of the balanced scorecard concepts and relationships are fairly open to different interpretations (Norreklit, 2003; Ax and Bjornenak, 2005). In this context, Chenhall (2003, p. 130) suggests that developing a valid measure of what represents balanced scorecard usage would be useful, and then researchers can explore its context. Such a valid measure would also enhance consistency between studies. According to Mooraj et al. (1999, p. 489), the balanced scorecard implementation process relies on both formal and informal processes, however, each company has a unique balanced scorecard. Recently, Marcela et al. (2003) argue that there are difficulties when designing the balanced scorecard,

especially the selection of performance measures and their relationships. Moreover, they suggested two possible options to overcome the difficulties. The first is to use the balanced scorecard as a model of control, and the second uses balanced scorecard as a model for implementing the strategy of the company. As indicated in Chapter 3, section 3.4, a recent study by Speckbacher et al. (2003) operationalised balanced scorecard as three types based on the evolution of the concept. These types are:

- Type one balanced scorecard: A multidimensional framework for strategic performance measurement that combines financial and non-financial measures.
- Type two balanced scorecard: A type one balanced scorecard that additionally describes strategy by using cause-and-effect relationships.
- Type three balanced scorecard: A type two balanced scorecard that additionally implements strategy by defining action plans/targets and by linking compensation plans to BSC measures.

Following Krumwiede (1998) and Ittner, Larcker and Randall (2003), a seven-point scale is used to measure the implementation stage of the balanced scorecard, where 1 = not considered, 2 = implemented and abandoned, 3 = considering, 4 = approved for implementation, 5 = implementing now, 6 = used, and 7 = used extensively. An essential core element of balanced scorecard usage is the number of perspectives. A recent study conducted by Bisbe and Otley (2004) defined the use of balanced scorecard as multi-perspective sets of both financial and non-financial measurements that aim to capture the extent to which strategic objectives are being achieved. Thus, financial, customer, internal business process (i.e. operational), and learning and growth (i.e. innovation) perspectives were used in this study. This is supported by the empirical work (Hoque and James, 2000; Hoque et al., 2001; Sohn et al., 2003; Speckbacher et al., 2003; Maiga and Jacobs, 2003). In addition, supplier, employee, and environment perspectives were added in this study based on the argument raised by Kaplan and Norton and other researchers such as Neely et al. (1995) and Olve et al. (1999).

Two additional questions were used to ascertain that the responding companies are using the main features 'assumptions' of the balanced scorecard according to Kaplan and Norton (1996c) and the recent balanced scorecard literature (Hoque and James, 2000; Norreklit, 2000; Malmi, 2001; Speckbacher et al., 2003). These questions deal with the extent to which

the company links performance measures to business strategies, and the extent to which these performance measures are causally linked to each other and also to financial performance outcomes. Additional questions were also used to identify the number of strategic objectives and strategic measurements that are incorporated in the scorecard for each perspective. Finally, two questions were utilised to investigate the results achieved from implementing this approach and the level of implementation in the organisational hierarchy.

Finally, it should be noted that this sub-section intended to provide a broad view of the items used to measure the extent of balanced scorecard usage. A further explanation of how the extent of balanced scorecard usage (BSCUSE) was measured is provided in Chapter 8, sub-section 8.2.9.

5.4.4 Operationalising organisational effectiveness

According to the contingency theory literature, the relationship between the contingent variables and management control system should consider organisational effectiveness (Waterhouse and Tiessen, 1978; Otley, 1980; Otley and Wilkinson, 1988). According to AAA (1971), effectiveness is a concept associated with goal attainment, and this measure represents the degree to which each goal is attained. However, three dimensions to measure effectiveness have been utilised in contingency research: efficiency, preference of organisational members and general social dimensions (Tosi and Slocum, 1984). Empirical contingency theory studies have measured organisational effectiveness in different ways. For instance, several studies (e.g. Simons, 1987) have used financial metrics to measure organisational effectiveness. Other studies (e.g. Govindarajan and Gupta, 1985; Hoque and James, 2000) have used both financial and non-financial metrics to measure organisational effectiveness. Several studies (e.g. Rigby, 2001; Sandt et al., 2001) have also assessed the performance implications of strategic performance measurement by the level of satisfaction.

Based on the aforementioned discussion, this research assesses organisational effectiveness of using performance measurement diversity using two sets of variables:

- **Organisational performance:** Following Govindarajan (1984), a multiplicity of financial and non-financial measures is used to operationalise organisational effectiveness. A two

stage rating² scale was employed. First, respondents were asked to indicate the importance of eight performance measures to their organisations. These included cash flow, market share, return on investment, new product development, market development, cost reduction, research and development, and personnel development. Second, respondents were asked to indicate how they perceive their organisations actually performed in respect of these performance measures. The rationale for using this measure is to seek to document whether improved performance is observed through the usage of performance measurement diversity.

- Level of satisfaction: Following Ittner, Larcker and Randall (2003), managers' satisfaction with the performance measurement system is used. Three questions are used to measure company's satisfaction with its measurement system: (1) how well the performance measurement system meets expectations; (2) how well the system compares to the manager's concept of an ideal system; (3) overall satisfaction with the performance system. The rationale for this definition is to allow the researcher to compare the results with other studies in the literature.

5.5 Research variables and hypotheses formulation

This section describes the main hypotheses of the study. They are divided into three groups. The first group of hypotheses is related to the contingent variables that might affect the extent of usage of performance measurement diversity (PMD). The second group of hypotheses is related to the effectiveness of performance measurement diversity. The third group is related to the contingent variables that might affect the extent of usage of balanced scorecard (BSCUSE).

5.5.1 Hypotheses relating to factors influencing the extent of performance measurement diversity usage (PMD)

The contingency theory framework has been used in this research to achieve some of the research objectives. The preceding literature (Chapter 4, section 4.7) also supported the theory that the use of performance measurement diversity is contingent on organisational characteristics. Thus, the seven contingent variables specified in Figure 5.1 are addressed to

² The reason in favour of using self-ratings is to overcome the inconsistencies in the companies' archival data. This data is inconsistent because different companies might utilise different accounting methods to calculate earnings. In addition, this type of data might be not available.

examine the relationship between contingent variables and the extent of performance measurement diversity usage.

5.5.1.1 Business strategy and the extent of PMD usage

Business strategy is one of the fundamental variables of contingency theory because of the potential to affect the design and use of management control systems (Govindarajan and Gupta, 1995; Simons, 1990). The choice of performance measures is associated with business strategy (Govindarajan and Fisher, 1990; Abernethy and Lillis, 1995; Hussain and Gunasekaran, 2002). Chapter Four concluded that the literature concerning the effect of business strategy on control system design is controversial and unclear (Otley and Wilkinson, 1988; Langfield-Smith, 1997). In sum, there is a considerable body of evidence that gives support for the effect of business strategy on the choice of performance measures (e.g. Drucker, 1990). However, a company's business strategy is likely to affect the relative informativeness of alternative performance measures (Ittner et al., 1997). Defender companies follow a low cost orientation and focus on minimising costs through improvements in operations. This focus leads companies to employ financial performance measures (Simon, 1987; Govindarajan and Fisher, 1990). In contrast, prospector companies follow a differentiation orientation by focusing on new products and markets. This focus leads companies to be less informative towards financial performance measures (Saïd et al., 2003).

Based on the results of previous empirical studies (see Chapter 4, sub-section 4.7.1), it can be expected that companies that pursue a differentiation strategy are more likely to use performance measurement diversity by placing more emphasis on non-financial performance measurements. Conversely, companies pursuing a low cost strategy are less likely to use performance measurement diversity. Thus, it can be hypothesised that:

H1a: *Low cost strategy has a negative impact on the extent of performance measurement diversity usage.*

H1b: *Differentiation strategy has a positive impact on the extent of performance measurement diversity usage.*

5.5.1.2 Organisational structure and the extent of PMD usage

The structure of organisations has been used in the early contingency theory studies. However, researchers such as Kaplan and Norton (2001) and Nilsson and Kald (2002) argued that the use of multiple performance measures in terms of financial and non-financial depends on the characteristics of the organisation. To recall from the discussion in Chapter 4, it can be concluded that the relationships between structure and accounting information systems are not clear and needs more investigation (Gordon and Narayanan, 1984; Chenhall, 2003). In this context, Dalton et al. (1980) concluded that little is known about the association between centralisation and performance measurement, and the association between formalisation and performance measurement has not been convincingly demonstrated. Based on the limited evidence provided by the literature review (see Chapter 4, sub-section 4.7.2), the relationship between organisation structure and the extent of performance measurement diversity usage is presented as research questions rather than as hypotheses: Does organisational structure have a direct influence on the extent of performance measurement diversity usage? This question can be divided into two sub-questions in this research:

Research question 1: *Does the structural dimension of centralisation have a direct impact on the extent of performance measurement diversity usage?*

Research question 2: *Does the structural dimension of formalisation have a direct impact on the extent of performance measurement diversity usage?*

5.5.1.3 Perceived environmental uncertainty and the extent of PMD usage

Perceived environmental uncertainty is one of the crucial contingent variables that have been widely used in management accounting information characteristic research. This argument has gained considerable support in the contingency theory management accounting literature (Gordon and Miller, 1976; Gordon and Narayanan, 1984; Chenhall and Morris, 1986). In addition, there has been much empirical evidence which has indicated that the increase level of perceived environmental uncertainty leads to a greater need for management accounting information in terms of non-financial performance measurements (Chenhall and Morris, 1986; Gul and Chia, 1994; Cauvin and Bescos, 2002; Chenhall, 2003). As indicated in Ittner et al. (1997), non-financial performance measurements are extensively used in regulated

industries. They also argued that in regulated industries government intervention may lead companies to place greater emphasis on non-financial performance measurements. Therefore, it can be argued that regulated companies would rely more on non-financial performance measurements than non-regulated companies (Said et al., 2003). However, companies should predict the conditions that will exist during the coming years, and this can be done more accurately under stable environmental conditions than dynamic and changing conditions (Govindarajan, 1984). Based on the results of previous empirical studies (see Chapter 4, sub-section 4.7.3), it can be hypothesised that:

H2: *Perceived environmental uncertainty has a positive impact on the extent of performance measurement diversity usage.*

5.5.1.4 Intensity of competition and the extent of PMD usage

Market competition is one of the crucial determinants that affect the use of management control systems in manufacturing companies (Khandawalla, 1972; Simons, 1990; Chenhall, 2003). As competitive pressures continue to intensify in the marketplace, companies are demanding more from their performance measurement systems. Considering the effect of competition on the use of non-financial performance measurements, several studies concluded that traditional performance measurements are inappropriate in today's competitive environment. A business unit facing intense market competition is likely to make greater use of multiple performance measurements than just financial measurements (Lynch and Cross, 1995). These measures include the use of both traditional financial measurements and non-financial performance measurements. Based on the results of previous research (see Chapter 4, sub-section 4.7.4), it can be hypothesised that:

H3: *Intensity of competition has a positive impact on the extent of performance measurement diversity usage.*

5.5.1.5 Organisation size and the extent of PMD usage

In the contingency theory literature, there has been much empirical evidence which indicates that organisation size may affect the use of management control systems, the sophistication of control and information systems (Khandawalla, 1972; Merchant, 1984; Otley and Wilkinson, 1988; Ezzamel, 1990; Libby and Waterhouse, 1996). In terms of performance

measurement usage, Verbeeten (2004) found in his empirical work that organisation size is positively associated with the use of non-financial performance measurements. Based on the aforementioned results and the previous arguments (see Chapter 4, sub-section 4.7.5), it can be hypothesised that:

H4: *Organisation size has a positive impact on the extent of performance measurement diversity usage.*

5.5.1.6 Total quality management and the extent of PMD usage

The literature concerning management accounting has shown increasing levels of adoption of total quality management by manufacturing companies. The rise of the total quality management movement drew the attention of managers to the importance of focusing on the non-financial performance measurements (Letza, 1996). However, the association between quality initiatives and the increasing use of non-financial performance measurements has been identified in management accounting research. In this context, Chenhall (1997) and Sim and Killough (1998) empirically supported the relationship between using several non-financial performance measurements and the application of total quality management initiatives. Based on the above argument and the previous arguments (see Chapter 4, sub-section 4.7.6.1), it can be hypothesised that:

H5: *The extent of the use of total quality management has a positive impact on the extent of performance measurement diversity usage.*

5.5.1.7 Just in time manufacturing approaches and the extent of PMD usage

The literature review in the previous chapter has revealed that organisations implementing just in time manufacturing approaches are associated with the greater use of non-financial performance measurements (Banker et al., 1993; Upton, 1998). However, the association between just in time manufacturing approaches and the increasing use of non-financial performance measurements has been identified in management accounting research. In this context, Upton (1998) and Fullerton and McWatters (2002) empirically supported the relationship between the degree of implementation of just in time manufacturing approaches and the adoption of several non-financial performance measurements within the management

accounting system. Based on the above argument and the previous arguments (see Chapter 4, sub-section 4.7.6.2), it can be hypothesised that:

H6: *The extent of the use of just in time manufacturing approaches has a positive impact on the extent of performance measurement diversity usage.*

5.5.2 Hypotheses relating to the effectiveness of PMD usage

It has been argued in sub-section 5.2.1 that the relationship between management control systems and organisational effectiveness is not empirically clear. In addition, theoretical research on the economic benefits from greater measurement diversity is ambiguous (Ittner, Larcker and Randall, 2003, p. 718). However, prior research (e.g. Govindarajan and Fisher, 1990) suggests that companies that align their performance measurements with contingency variables achieve higher performance.

It was pointed out in Chapter 4, section 4.3 that the systems approach of fit emphasises the need to investigate patterns of consistency among contingent variables, management control system and organisational effectiveness. This approach of fit assumes that any one variable alone is insufficient for achieving organisational effectiveness. However, coalignment is a dynamic and never-ending task, whereby the organisation is continually ‘shooting at a moving target of coalignment’ (Thompson, 1967, p. 234). According to Venkatraman (1989, p. 441), no organisational system is in a state of perfect dynamic coalignment, but every organisation is moving towards this state. Therefore, the coalignment or fit among the seven contingent variables specified in Figure 5.1 and performance measurement diversity usage will affect organisational effectiveness (i.e. in terms of organisational performance and the level of satisfaction). As a result, the claimed and limited evidence on the effectiveness of performance measurement diversity usage, leads to the following hypotheses:

H1a: *The fit or coalignment among the extent of performance measurement diversity usage, business strategy, organisational structure, perceived environmental uncertainty, intensity of competition, size, total quality management and just in time manufacturing approaches has a positive impact on organisational performance.*

H1b: *The fit or coalignment among the extent of performance measurement diversity usage, business strategy, organisational structure, perceived environmental uncertainty, intensity of competition, size, total quality management and just in time manufacturing approaches has a positive impact on performance measurement system satisfaction.*

5.5.3 Hypotheses relating to factors influencing the extent of balanced scorecard usage

To recall from our discussion in sub-section 5.5.1, contingency theory framework has been employed in this research to achieve some of the research objectives. The application of a contingency theory to explain the extent of usage of the balanced scorecard has been advocated by management accounting researchers due to the shortages in this type of research (see Sub-section 5.2.2). Thus, the same contingent variables that were used in the performance measurement diversity model and presented in Figure 5.2 are addressed to examine the relationship between contingent variables and the extent of balanced scorecard usage. Also, it has been argued in sub-section 5.4.3 that several terms exist on the definition of the balanced scorecard. Thus, this research provides a more sophisticated measure of identifying the extent of usage of the balanced scorecard and the contingent variables (for a detailed discussion of these measures see Chapter 8, section 8.2).

5.5.3.1 Business strategy and the extent of balanced scorecard usage

There are few empirical studies which supports the relationship between business strategy and the use of several management accounting practices such as activity-based costing systems and balanced scorecard approach (e.g. Gosselin, 1997; Chenhall and Langfield-Smith, 1998b; Anderson and Lanen, 1999; Olson and Slater, 2002). In this context, Ittner, Larcker and Randall (2003) argued that the extent to which companies claiming to use the balanced scorecard actually link their performance measurements more closely to strategic priorities is unknown. Moreover, Hoque et al. (2001) suggested that there is a need for further investigations of how a set of performance measurements, rather than single measurement, could be useful to organisations operating in varied industries with various competitive strategies. However, past empirical studies (e.g. Olson and Slater, 2002; Sohn et al., 2003) have investigated the relationship between business strategy and the usage of balanced scorecard perspectives. These studies have shown that prospector companies follow a differentiation orientation place greater emphasis on the usage of non-financial perspectives of the balanced scorecard, while defender companies following a low cost orientation place a

greater emphasis on the usage of financial perspectives of the balanced scorecard. Accordingly, it can be expected that companies pursuing differentiation strategy are more likely to use the balanced scorecard approach than companies that pursuing low cost strategy. Thus, it can be hypothesised that:

H1a: *Low cost strategy has a negative impact on the extent of balanced scorecard usage.*

H1b: *Differentiation strategy has a positive impact on the extent of balanced scorecard usage.*

5.5.3.2 Organisational structure and the extent of balanced scorecard usage

Several researchers argue that organisational structure may influence the adoption and implementation of innovation (Damanpour, 1991; Gosselin, 1997, Mooraj et al., 1999). In this context, Gosselin (1997) found that ABC adoption is associated with vertical differentiation. In contrast, ABC implementation is associated with centralised decision-making and formalised job procedures. In terms of balanced scorecard, Braam and Nijssen (2004a) argue that the chance of adoption of balanced scorecard is more likely in high centralised organisations. Recently, Sohn et al. (2003) argue that the choice of the balanced scorecard may rely on the extent of centralisation and formalisation.

Based on the limited evidence provided by the literature review (see Chapter 4, sub-section 4.7.2), the relationship between organisational structure and the balanced scorecard extent of usage is presented as research questions rather than hypotheses: Does organisational structure have a direct influence on the extent of balanced scorecard usage? This question can be divided into two sub-questions in this research:

Research question 1: *Does the structural dimension of centralisation have a direct impact on the extent of balanced scorecard usage?*

Research question 2: *Does the structural dimension of formalisation have a direct impact on the extent of balanced scorecard usage?*

5.5.3.3 Perceived environmental uncertainty and the extent of balanced scorecard usage

To recall from our discussion in sub-section 5.5.1.3, the evidence from management accounting research shows that the greater the uncertainty in the external environment the greater the need for non-financial and future oriented information. In addition, Chow et al. (1997) argued that applications of the balanced scorecard has been mostly confined to organisations facing a more turbulent and competitive environment. One way to understand the use of the balanced scorecard approach is to consider whether companies are facing an unstable environment (Malmi, 2001). Recently, Sohn et al. (2003) found that an uncertain environment has a significant impact on the usage of balanced scorecard perspectives. Thus, it can be hypothesised that:

H2: *Perceived environmental uncertainty has a positive impact on the extent of balanced scorecard usage.*

5.5.3.4 Intensity of competition and the extent of balanced scorecard usage

The integration or balance in the performance measurement system is necessary for the organisation's long-term success in today's competitive environment (Kaplan, 1983; Nanni et al., 1992; Euske et al., 1993). The literature on the balanced scorecard approach has revealed that the level of competition is the most important factor that may affect the usage of balanced scorecard approach (Hoque and James, 2000; Malmi, 2001). Recently, Maiga and Jacobs (2003) argued that balanced scorecards are implemented in response to the competitive environment. Empirically, several studies (e.g. Hoque et al., 2001; Banker et al., 2001) found that companies implementing the balanced scorecard approach are facing high levels of market competition. Based on the findings of previous empirical studies, it can be expected that companies facing greater competitive pressures are more likely to use the balanced scorecard approach. Thus, it can be hypothesised that:

H3: *Intensity of competition has a positive impact on the extent of balanced scorecard usage.*

5.5.3.5 Organisation size and the extent of balanced scorecard usage

It has been argued in Chapter 4, sub-section 4.7.5 that empirical studies on the relationship between organisation size and innovation have shown mixed results. For example, researchers such as Bjornenak (1997) and Lawson et al. (2003b) found that management

accounting innovation adoption rates are higher in larger organisations than smaller organisations. In contrast, Gosselin (1997) reported no relationship between organisation size and the decision to adopt the ABC. In the same vein, researchers (e.g. Hoque and James, 2000; Speckbacher et al., 2003) have found that balanced scorecard usage is positively associated with organisation size. Thus, it can be hypothesised that:

H4: *Organisation size has a positive impact on the extent of balanced scorecard usage.*

5.5.3.6 Total quality management and the extent of balanced scorecard usage

It has been argued in Chapter 4, sub-section 4.7.6.1 that traditional financial performance measurements alone are inappropriate in total quality management settings. In addition, it has been pointed out in sub-section 5.5.1.6 that organisations implementing total quality management initiatives are associated with greater use of non-financial performance measurements. Empirically, Malmi (2001) reported in his interviews that one of the important initiatives to encourage the adoption of the balanced scorecard is the use of total quality management. Recently, Hoque (2003) recommend using the balanced scorecard approach to support the implementation of total quality management initiatives. Based on the above discussion, it can be expected that companies pursuing total quality management are more likely to use the balanced scorecard approach. Thus, it can be hypothesised that:

H5: *The extent of the use of total quality management has a positive impact on the extent of balanced scorecard usage.*

5.5.3.7 Just in time manufacturing approaches and the extent of balanced scorecard usage

It has been argued in Chapter 4, sub-section 4.7.6.2 that traditional financial performance measurements alone are inappropriate in organisations implementing just in time manufacturing approaches. In addition, it has been pointed out in sub-section 5.5.1.7 that organisations implementing just in time manufacturing approaches are associated with greater use of non-financial performance measurements. More specifically, researchers such as Clinton and Hsu (1997) argue that the usage of the balanced scorecard approach might support the implementation of just in time manufacturing approaches. Accordingly, it can be

expected that companies implementing just in time manufacturing approaches are more likely to use the balanced scorecard approach. Therefore, it can be hypothesised that:

H6: *The extent of the use of just in time manufacturing approaches has a positive impact on the extent of balanced scorecard usage.*

5.6 Summary

The literature review that has been carried out in Chapters 2-4 identified several important gaps and justifications for building the research theoretical models, and these were discussed thoroughly in section 5.2. The illustration forwarded in respect of the research theoretical models highlighted that the current research extends earlier studies to achieve the research objectives. Moreover, management accounting studies (e.g. Otley, 1999; Malmi, 2001; Maltz et al., 2003) have advocated researchers to develop measurement instruments to identify the extent of usage of balanced scorecard approach. Therefore, the operational definition of the research variables particularly the extent of performance measurement diversity usage, the extent of balanced scorecard usage and organisational effectiveness provide a comprehensive view of these variables. Finally, the anticipated relationships between the contingent variables, the extent of performance measurement diversity usage, the extent of balanced scorecard usage and organisational effectiveness were thoroughly discussed in order to underpin the formulation of the hypotheses and research questions.

Chapter 6

Research methodology

6.1	Introduction.....	6-2
6.2	Research philosophy.....	6-2
6.3	Research design.....	6-6
6.4	Research population.....	6-8
6.5	Research sample and sampling frame.....	6-9
6.6	Data collection methods.....	6-11
	6.6.1 Interviews.....	6-12
	6.6.2 Questionnaire types and formats.....	6-12
	6.6.2.1 Personally administered questionnaires.....	6-12
	6.6.2.2 On-line questionnaires.....	6-13
	6.6.2.3 Mail questionnaires.....	6-13
6.7	Questionnaire construction and pre-testing.....	6-14
	6.7.1 Question types and format.....	6-15
	6.7.2 Questionnaire layout and flow.....	6-17
	6.7.3 Questionnaire pre-testing and pilot work.....	6-18
6.8	Features of the covering letter.....	6-20
6.9	Content of the final draft of the questionnaire.....	6-21
6.10	The individual respondents.....	6-24
6.11	Administering the questionnaire and response profile.....	6-24
	6.11.1 Characteristics of responding firms.....	6-25
	6.11.2 Characteristics of respondents.....	6-26
6.12	Check for non-response bias.....	6-27
6.13	Validity and reliability.....	6-30
	6.13.1 Validity.....	6-30
	6.13.2 Reliability.....	6-32
6.14	Statistical methods used in data analysis.....	6-32
	6.14.1 Descriptive statistics.....	6-33
	6.14.2 Exploratory factor analysis (EFA).....	6-34
	6.14.3 Structural equation modelling (SEM).....	6-34
	6.14.4 Correlation and multiple regression.....	6-37
6.15	Summary.....	6-38

Chapter 6

Research methodology

6.1 Introduction

Chapters 2-4 have provided a literature review on the performance measurement systems, balanced scorecard approach and the contingency theory theoretical framework. The orientation towards this particular area was mainly due to the need to explore more about the performance measurements and the balanced scorecard. In general, research can be conducted for two purposes. One is to solve a currently existing problem and it is called applied research, the other is to contribute to the general body of knowledge in a particular area of research and it is called basic or fundamental research (Sekaran, 1992). Based on the above classifications, this study falls within basic research, because it aims to understand more about the extent of usage of both performance measurements and the balanced scorecard in manufacturing companies.

The aim of this chapter is to explain the research philosophy and design that has been employed by this study. More specifically, this chapter is structured as follows: it starts with a brief discussion of the research philosophies and the selected methodology. This is followed by an explanation of the research design. It then describes the research population and sampling procedures. This is followed by a description of the data collection methods, questionnaire construction and pre-testing, content of the final draft of the questionnaire, features of the covering letter, the targeted respondents and survey administration and response profile. Finally, the chapter ends with a discussion of the statistical methods used in this research.

6.2 Research philosophy

It is important to conduct any research based on principles of methodology. According to Hussey and Hussey (1997), researchers have to determine their research paradigm before constructing the research design. This determination has important implications for research methodology. Before describing the detailed research philosophies, it is important to differentiate between research techniques and design. Oppenheim (1992) indicates that research techniques are the methods for data collection. Research design is concerned with the plan of the research, and the logic behind it, which will make it possible to draw general

conclusions. Research design is an important choice and has a major role to play on the whole research (Hussey and Hussey, 1997). Moreover, Creswell (2003) argues that a researcher should choose his research design at an early stage of the research, because research design determines: (1) research methodology, (2) data collection methods, and (3) data analysis and interpretation methods. According to Easterby-Smith et al. (2002), understanding the philosophical issues of research is useful for the following reasons:

- It can sustain in clarifying research design;
- It can help the researcher to recognise the suitable design for the research; and
- It can help the researcher to identify and create designs that may be outside researchers past experience.

Paradigm is defined as the progress of scientific practice based on people’s philosophies and assumptions about the world and the nature of knowledge (Hussey and Hussey, 1997). Paradigms offer a framework comprising an accepted set of theories, methods and ways of defining data. According to Easterby-Smith et al. (2002), there are two main research philosophies or paradigms, positivistic and social constructionism. The implications of both philosophies are presented in Table 6.1.

Table 6.1 Implications of positivism & social constructionism. Source: Easterby-Smith et al. (2002), p. 30

	Positivism	Social Constructionism
The observer	Must be independent	Is part of what is being observed
Human interest	Should be irrelevant	Are the main drivers of science
Explanations	Must demonstrate causality	Aim to increase general understanding of the situation
Research progress through	Hypotheses and deductions	Gathering rich data from which ideas are induced
Concepts	Need to be operationalised so that they can be measured	Should incorporate stakeholder perspectives
Units of analysis	Should be reduced to simplest terms	May include the complexity of whole situation
Generalisation through	Statistical probability	Theoretical abstraction
Sampling requires	Large numbers selected randomly	Small numbers of cases chosen for specific reasons

Several terms had been used in describing research paradigms. Table 6.2 summarises the most common terms for the main research paradigms.

Table 6.2 Alternative terms for the research paradigms. Source: Hussey and Hussey (1997), p. 47

Positivistic paradigm	Phenomenological paradigm
Quantitative Objectivist Scientific Experimentalist Traditionalist	Qualitative Subjective Humanistic Interpretivist

In this context, Hussey and Hussey (1997) indicate that the most popular terms across authors are quantitative and qualitative. They also argue that the choice of either paradigm is determined by the current knowledge of the topic under investigation, and the research objectives. Moreover, both paradigms have an important part to play in business and management research (Saunders et al., 2000). According to Amaratunga (2002), the quantitative approach searches for causal explanations and fundamental laws, and generally reduces the whole to simplest possible elements in order to facilitate analysis. In contrast, the qualitative approach is used to inductively and holistically understand human experiences in context-specific setting. The quantitative paradigm tends to relate variables in hypotheses, which are then tested by employing statistical procedures. The results may confirm or verify the theory (Hussey and Hussey, 1997). In contrast, the qualitative paradigm requires clear knowledge about the phenomena under investigation, which is then tested in its wider context over time (Creswell, 2003). Creswell (2003) also argued that the strategies, knowledge claims and the methods all contribute to three approaches to research. These approaches are quantitative, qualitative and mixed. The following are the definitions for each approach that have been identified by Creswell (2003):

- A quantitative approach is one in which investigator primarily uses post-positivist claims for developing knowledge, employs strategies of inquiry such as experiments and collects data on predetermined instruments that yield statistical data.
- A qualitative approach is one in which inquirer often makes knowledge claims based on constructivist perspectives for developing knowledge, employs strategies such as case studies and the researcher collects open-ended data and emerging data with the primary intent of developing themes from the data.
- A mixed approach is one in which the researcher tends to base knowledge claims, employs strategies and collects data. The final database represents both quantitative and qualitative information.

The research philosophies have essential assumptions and implications regarding how research should be conducted (Creswell, 2003). In general, determining the most appropriate philosophy is an on going debate between researchers (Easterby-Smith et al., 2002). Therefore, understanding the strengths and weaknesses of both paradigms provides the researchers with insightful aspects to their research situation. Examples of the strengths and weaknesses of the quantitative and qualitative paradigms are presented in Table 6.3.

Table 6.3 Strengths and weaknesses of research schools. Source: Amaratunga (2002), p. 20

Theme	Strengths	Weaknesses
Positivist (quantitative paradigm)	<ul style="list-style-type: none"> - They can provide wide coverage of the range of situation. - They can be fast and economical. - Where statistics are aggregated from large samples, they may be of considerable relevance to policy decisions. 	<ul style="list-style-type: none"> - The methods used tend to be rather inflexible and artificial. - They are not very effective in understanding processes or the significance that people attach to actions. - They are not very helpful in generating theories. - Because they focus on what is, or what has been recently, they make it hard for policy makers to infer what changes and actions should take place in the future.
Phenomenological (qualitative paradigm)	<ul style="list-style-type: none"> - Data-gathering methods seen as natural than artificial. - Ability to look at change processes overtime. - Ability to understand people's meaning. - Ability to adjust to new issues and ideas as they emerge. - Contribute to theory generation. 	<ul style="list-style-type: none"> - Data collection can be tedious and require more resources. - Analysis and interpretation of data may be more difficult. - Harder to control the pace, progress and end-points of research process. - Policy makers may give low credibility to results from qualitative approach.

Adopting the quantitative (positivistic) paradigm generally leads to the employment of the deductive approach with specific research methodologies such as longitudinal studies, cross-sectional studies and surveys. In contrast, adopting the qualitative (phenomenological) paradigm generally leads to the employment of the inductive approach with research methodologies such as case studies. Earlier, Creswell (1994) suggested several criteria to determine the appropriate research approach to adopt. Based on these criteria, Saunders et al. (2000, p. 91) argued that the most important of these are:

1. The research topic. A topic with a wealth of literature that helps in developing theoretical framework and hypotheses leads to adopting the deductive approach. It may be more appropriate to adopt the inductive approach for research into a new topic with little existing literature.
2. Time available to the researcher. The deductive research can be quicker to complete. On the other hand, inductive research can be much more protracted. Therefore, the deductive approach can be a lower-risk strategy than the inductive approach.
3. Audience preferences. Most managers are familiar with the deductive approach and much more likely to put faith in conclusions resulting from this approach.

Based on the aforementioned criteria, this research has adopted a quantitative (positivistic) paradigm in its design to achieve the research objectives, and to provide a basis for generalising the results. This leads to the adoption of a research methodology that is

concerned with employing quantitative methods of data collection. In this context, Hussey and Hussey (1997) argued that the dominant paradigm in business research is the positivistic paradigm resulting in researchers not having to expend time justifying the methodology adopted. In contrast, the phenomenological paradigm may require much time for researchers to justify the methodology adopted. In addition to Hussey and Hussey's (1997) argument, the following justifications supported the selected philosophy for this research:

- Most of the contingency theory management control system studies have been conducted by adopting a quantitative research philosophy in their design to examine the expected relationships between contingent variables and management control system. For example, Gordon and Narayanan (1984), Chenhall and Morris (1986), Gul (1991), Gul and Chia (1994), Chia (1995).
- Some of the empirical studies have been carried out by adopting a quantitative philosophy in their design to explore the expected relationships that might emerge from the interaction between the contingent variables and the balanced scorecard. For example, Hoque and James (2000) and Olson and Slater (2002).
- In many cases, contingency theory researchers usually build their databases to overcome the resistance in gathering data. Therefore, researchers always obtain data through surveys (Fisher, 1998). In addition, management accounting researchers collect their own data contrary to financial accounting researchers. Thus, management accounting researchers tend to choose experiments and mail surveys (Otley, 2001).
- The literature review on the balanced scorecard has revealed that there is a need to conduct research surveys, because many of these studies have tended to be concerned with conducting case studies or forwarding theoretical arguments (Chenhall and Langfield-Smith, 1998a; Norreklit, 2000; Malmi, 2001). In this context, Marr and Schiuma (2003, p. 684) argued that much of the balanced scorecard research is case-based and it seems that there is a lack of large-scale empirical testing of the concept. Earlier, Foster and Young (1997, p. 76) believed that field research is not the only way to research new topics such as ABC and balanced scorecard. Thus, many ideas gathered from field studies can certainly be used to help develop effective surveys.

6.3 Research design

It has been argued in the previous section that choosing a certain research paradigm leads researchers to implement a specific research design. The extent of scientific rigour in

research depends on how the researchers choose the appropriate design. According to Sekaran (2003) there are several aspects of research design. These are: (1) the purpose of the study, (2) the type of investigation, (3) the extent of researcher interference with the study, (4) the study setting, (5) unit of analysis, and (6) time horizon.

- Purposes of the study

The purposes of this study can be classified descriptive and other aspects as hypotheses testing. The essential difference between these types of studies lies in their objectives (Cooper and Schindler, 2001). The main aim of descriptive studies is to describe the characteristics of the variables (Sekaran, 2003), whereas the objective of hypotheses testing is to explain the nature of certain relationships. One of the aims of this study is to ascertain the extent of usage of both performance measurement diversity (PMD) and the balanced scorecard, and which types of balanced scorecards UK manufacturing companies use. Therefore, this part of the research can be classified as descriptive study. On the other hand, the research aims to investigate the impact of several contingent variables on the extent of usage of both performance measurement diversity and the balanced scorecard. Thus, this part of the research can be classified to be hypotheses testing study.

- Type of investigation

Studies might be correlational or causal. Correlational studies are interested in the association between variables whereas causality studies deals with cause-and-effect relationships. Based on the former point, and consistent with the research objectives, this study is classified as causal study.

- The researcher's interference with the study

Sekaran (2003) indicated that there could be varying degrees of researcher interference in the manipulation and control of variables. Moreover, Sekaran (2003) stressed that most organisational problems call for a causal study. In this study, no attempt will be made by the researcher to manipulate the study variables.

- The study setting

Studies can be classified as lab or field studies. Lab studies are usually conducted in an artificial environment. Conversely, field studies are conducted in the actual environmental circumstances. This study is therefore classified as a field study because it was conducted under actual conditions.

- Unit of analysis

The unit of analysis refers to the level of aggregation of the data collected during the subsequent data analysis such as individuals, groups or organisations (Hussey and Hussey, 1997). The unit of analysis of this research is the business units.

- Time horizon

Studies might be longitudinal or cross-sectional. In longitudinal studies, data are gathered at more than one point in time whereas in cross-sectional studies data are gathered once, perhaps over a period of days or weeks. Cross-sectional studies often employ the survey method (Easterby-Smith et al., 2002). This research has been conducted at one point in time, so it is a cross-sectional or one-shot research.

6.4 Research population

The term population refers to the entire group of people, events, or things of interest under investigation, and the population frame is a listing of all the elements in the population from which the sample is drawn (Sekaran, 2003). The population for this research is defined as all large manufacturing companies in the UK. The rationale for targeting the manufacturing companies in the UK is as follows:

- This research restricts the sample to manufacturing companies to implicitly control the large number of confounding variables that can substantively affect any results from a multi-industry. Although, depending on one industry limits the ability to generalise the results this is consistent with Ittner, Larcker and Randall (2003) recommendations.
- The manufacturing companies are more relevant and clearly reflect the constructs of this research since its variables, such as new manufacturing practices (i.e. TQM and JIT), intensity of competition, and business strategy are more related to the manufacturing companies rather than not-for-profit organisations.
- Large companies are targeted in the population and small companies were excluded from this study. The rationale for this is that large companies are expected to have a well designed management control system in general and performance measurement system in particular. Conversely, small companies employing less than 200 employees, are expected not rely on well designed performance measurement system.

- The issue of non-financial performance measurements and their combination with financial performance measurements is now receiving increasing emphasis in the manufacturing industries (Medori and Steeple, 2000; Hussain and Gunasekaran, 2002).
- The literature of contingency theory approach and management control system focuses on conducting the empirical studies in the field of manufacturing companies (e.g. Waterhouse and Tiessen, 1978; Gordon and Narayanan, 1984; Chenhall and Morris, 1986; Gul, 1991; Chia, 1995).
- Only manufacturing organisations were targeted because of the difficulty of designing a single questionnaire applicable to both services and manufacturing organisations. Consideration was given to producing two questionnaires, one for manufacturing and the other for services. However, it is extremely difficult to make generalisation about service organisations because of their distinctive features. Banks are quite different from hospitals, and hospitals are different from universities. Thus, it was considered that it would not be possible to design a single questionnaire that would be applicable to all types of service organisations.

6.5 Research sample and sampling frame

After defining the population, it was necessary to identify an appropriate sample and a suitable sampling frame. Selecting a sample is a fundamental element of a positivistic study (Hussey and Hussey, 1997). The reasons for sampling are the lower cost, greater accuracy, and greater speed of data collection and the availability of population elements (Cooper and Schindler, 2001). A representative sample should be large enough to satisfy the needs of the study and should be chosen at random and be unbiased (Hussey and Hussey, 1997). The sampling frame for any sample is a complete list of all the cases in the population from which the sample will be drawn (Saunders et al., 2000). Initially, it was necessary to determine appropriate criteria to be used to select the sample of the study. The criteria for selecting relevant information for each company are related to industry sector size, and the names of the respondents and their job titles.

Of particular interest to this stage was the identification of the database. Two different databases were available at the University of Huddersfield for setting the sample frame. These were the Chartered Institute of Management Accountants (CIMA) and the Financial Analysis Made Easy (FAME). The first database considered was the CIMA database. It

listed 7069 members employed in the manufacturing sector. It contained detailed information relating to members' surnames, forenames, salutation, job title, company name, mail address, sector code and number of employees. The limitation of this database was that information relating to size category was too broad (i.e. 1-5 employees, 6-25, 26-200, 201-10,000, 10,001+). An effort was made to shorten the CIMA database to meet the criteria. This resulted in 5128 members operating in manufacturing companies with over 200 employees. Another effort was made to determine the number of companies within this database, so that only one member was included for each company. This shortened this list to 2520 companies.

The second database was FAME. This database contained information relating to company names and addresses, company type, number of subsidiaries, and sales turnover of 8163 manufacturing companies operating in the UK. According to the criteria for selecting the sampling frame of this study, the FAME database consisted of 6773 manufacturing companies that had a turnover that exceeded £10 million. The need for an appropriate number of large companies resulted in the exclusion of companies with a sales turnover of less than £50 million. This procedure shortened the list to 2048 companies with a turnover that exceeded £50 million. The rationale for this was because such companies would be likely to have an established performance measurement system and to be considering using the balanced scorecard. Eliminating small companies is necessary, since these companies are less likely to have a formal control system (Widener, 2004).

Based on the criteria chosen for determining the sampling frame and because no suitable list exists to compile the sampling frame (Saunders et al., 2000), it was decided to use FAME database for identifying the research sampling frame. Moreover, the need to obtain data from management accountants or financial directors resulted in the need to use the membership database of CIMA as a complementary database for providing information on the selected sample¹. After determining the sampling frame it was necessary to choose the sample method and the sample size. A random sample method was used because the researcher had constructed a sampling frame, and it was also more representative (Sekaran, 2003). A sample size of 900 companies was selected from the FAME database. The reason for selecting a large sample was to obtain a sufficient response rate and to ensure that the sample was

¹The rationale for this decision will be discussed in Section 6.10.

representative. This is constant with Saunders et al. (2000) and Cooper and Schindler (2001) who stress that it is important to choose large sample size to ensure necessary confidence with the data.

6.6 Data collection methods

Data collection methods are an integral part of research design. These methods have been widely used in social research (Oppenheim, 1992). The appropriate selection of data collection methods depends mainly on enhancing the value of the research. In particular, the selected methods should enable the researchers to achieve the objectives of the study. Data can be collected in a variety of ways, in different settings and from different sources (Sekaran, 2003). Qualitative methods of data collection include methods of interviews, focus groups and observations. Quantitative methods include methods of telephone surveys, structured interviews and questionnaires.

Two main methods have been used in performance and balanced scorecard research. First, case studies have been widely used to explore and describe the implementation of the balanced scorecard (e.g. Letza, 1996; Butler et al., 1997; Malmi, 2001). Second, surveys have also been used with balanced scorecard research (see Chapter 3, section 3.5 for a review). Case study research is subject to several barriers such as having an access to the companies and language barriers particularly for overseas researchers. Also, the literature on performance measurement systems is large and the contributions are often limited to the presentation of excellent case studies, while empirical investigations of a wider spectrum, such as surveys are rare (De Toni and Tonchia, 2001). Therefore, it was decided to use the survey method as an appropriate method for achieving the objectives of this research. The survey method is usually associated with the positivistic philosophy. It is a popular and common method in business and management research (Saunders et al., 2000). Observations, interviews and administering questionnaires are the three main data collection methods used in survey research (Sekaran, 2003). The choice of data collection methods depends on the facilities available, the time span and other costs and resources associated with gathering data (Sekaran, 2003). Questionnaires and interviews are used extensively in surveys (Easterby-Smith et al., 2002). Therefore, these two methods are examined in the following sub-sections.

6.6.1 Interviews

One method of data collection is to interview respondents to obtain information on the subject of interest. Interviews can be structured or unstructured, and can be conducted either by face to face, or telephone or online. Each one of these methods has advantages as well as disadvantages (Hussey and Hussey, 1997). According to Oppenheim (1992), the advantage of interviews is that they improve response rates and they give a prepared explanation of the purpose of the study. They also provide an opportunity to contact interviewees and motivate them to provide additional information and reliable answers (Cooper and Schindler, 2001). The disadvantages of interviews are that they are expensive and time consuming. It was indicated by Oppenheim (1992, p. 83) that interviews will take weeks if not months to complete the study. There are also risks of interviewer biases and such interviews may cost more, when a wide geographic region is covered (Sekaran, 2003).

6.6.2 Questionnaire types and formats

A questionnaire is a list of carefully structured questions, chosen after considerable testing to achieve a reliable response from a chosen sample (Hussey and Hussey, 1997). This type of data collection method can be used for descriptive or explanatory research (Saunders et al., 2000). Questionnaires have the advantage of obtaining data more efficiently in terms of time, energy, and costs (Sekaran, 2003). Moreover, a questionnaire survey is cheaper and less time-consuming than conducting interviews (Hussey and Hussey, 1997). Several researchers (e.g. Oppenheim, 1992; Easterby-Smith et al., 2002; Sekaran, 2003) stress that questionnaires are the most popular method for collecting data and can be administered personally, electronically distributed or mailed to respondents.

6.6.2.1 Personally administered questionnaires

The personally administered questionnaire is usually presented to the respondents by an interviewer or by someone in an official position (Oppenheim, 1992). This type of questionnaire takes two forms in terms of the distribution method. The first form is self-administered questionnaires, in which the interviewer presents the questionnaire to the respondent, and then the respondent is left alone to complete the questionnaire. The second form is group-administered questionnaires, which is also given to groups of respondents assembled together in order to complete it. The main advantage of personally administered questionnaires is that the researcher collects the completed responses within a short period of

time, and any misleading questions can be clarified to the respondents (Sekaran, 2003). Conversely, the disadvantages are that organisations may be reluctant to give up company time for the survey with groups of employees assembled for the purpose. It is also an expensive and time consuming method (Hussey and Hussey, 1997).

6.6.2.2 On-line questionnaires

These types of questionnaires are delivered and returned electronically using either e-mail or the web site (Saunders et al., 2000). The e-mail questionnaire has several advantages. First, the elimination of paper costs and the reduction in distribution time. Second, the response rate should be increased because the researcher can make a direct contact with the respondents. As with the other methods of data collection this type of questionnaire has several disadvantages. First, the difficulty in determining the respondent's email address. Second, there is a problem of anonymity. Alternatively, the questionnaire can be advertised on the internet and respondents invited to access a web site to fill in the on-line questionnaire. As with the email method, this one also has disadvantages. Response rates are likely to be very low and there are considerable problems of non-response bias (Saunders et al., 2000).

6.6.2.3 Mail questionnaires

Mail questionnaires are a commonly used method in gathering data in social sciences (Oppenheim, 1992). The questionnaire and covering letter are posted to the respondents with a prepaid envelope for returning the completed questionnaire. This type of questionnaire can therefore be used for descriptive studies, and for examining and explaining relationships between variables (Saunders et al., 2000). The advantages of mail questionnaires are that they are most useful especially when large numbers of respondents are to be reached in different geographical regions. Also, respondents can take their time to respond at their convenience (Sekaran, 2003). Another main advantage of mail questionnaire is the low cost of data collection and processing (Cooper and Schindler, 2001). Moreover, mail questionnaires provide respondents with more confidence regarding their anonymity (Sekaran, 2003).

Mail questionnaires, however, suffer from low response rates (Oppenheim, 1992; Hussey and Hussey, 1997; Cooper and Schindler, 2001). Another disadvantage of the mail questionnaire

is that any doubts or misleading items cannot be clarified (Sekaran, 2003). In addition, the researcher cannot be sure that the targeted respondents have completed the questionnaire. Finally, there is no control over the order in which questions are answered or a check on incomplete questions (Oppenheim, 1992).

Based on the discussion in this chapter the survey instrument was considered most appropriate because it provides the large amount of cross-sectional data needed for this study. Further, an analysis of responses from a large number of companies, which are widely dispersed, would achieve the objectives of this research. A mail questionnaire was therefore considered to be the most appropriate method of data collection.

6.7 Questionnaire construction and pre-testing

In this phase, reviewing the literature identified the objectives of the study and the mail survey was selected as the most appropriate method for achieving these objectives. Before the development of the questionnaire the researcher identified that the balanced scorecard usage should be operationalised into several levels.

Developing a good questionnaire required a series of measures that would help to achieve the objectives of the study. The basic source for determining the content of the questionnaire was the literature. This major source was identified in order to maintain and maximise the reliability and validity of the questionnaire. Most of the questions used in this study were adapted from published research. In addition, the researcher made contacts with several researchers to discuss some of the questions related to the usage of balanced scorecard. Speckbacher et al. (2003, p. 368-369) have criticised balanced scorecard surveys. They argue that the analysis of balanced scorecard implementation does not depend on an objective analysis. They also noted that with some studies that companies were approached after the recommendation of consulting firms (e.g. Malmi, 2001). Other studies had insufficient feedback (e.g. Hoque and James, 2000; Rigby, 2001) or only estimated findings (e.g. Silk, 1998; Williams, 2001). They concluded that these procedures resulted in distorting the findings and they also had a low statistical power. Moreover, these procedures question whether the studies were adequate tests of the present state of balanced scorecard usage. In the same vein, Braam et al. (2002, p. 10) argued that most of balanced scorecard publications are purely conceptual, relating to what the concept is, and how it can be used. They also

argued that surveys on the diffusion of a concept generally suffer from the weakness that the researcher has no clue to what interpretations of a concept have been made. Therefore, in this crucial stage, it was essential that careful and detailed procedures were considered to avoid these criticisms and to develop a well-designed questionnaire because it offers only one chance to collect the data (Saunders et al., 2000). In addition, it is necessary to choose the question format to use (closed or open ended). Thus, the next sub-sections consider in more detailed the stages of constructing questions and the pre-survey issues and the pilot study.

6.7.1 Question types and format

Question design is related to the degree of validity and reliability of the research (Saunders et al., 2000), so the main decisions to be made in this stage related to the type of questions to be included (Easterby-Smith et al., 2002). Several researchers (e.g. Oppenheim, 1992; Saunders et al., 2000) suggest using guidelines for designing questions. In this context, Sekaran (2003, p. 237) indicated that there are three important issues in designing the questionnaire. These are related to:

- The wording of the questions.
- The general appearance of the questionnaire.
- How the variables should be categorised, scaled and coded.

Other issues were suggested by Hair et al. (2003, p. 189) relate to: (1) the concepts to be measured should be identified and defined and a method of measurement determined, and (2) decisions on classification and outcome information, types and wording of questions, questionnaire sequence and layout. However, all the suggested guidelines were used to minimise biases in this research. For example, the aim of the study was mentioned in the covering letter. In addition, efforts were made to use simple and clear questions. The wording of each question was carefully considered to provide one possible meaning and to avoid ambiguity. Moreover, a guideline statement was used before answering all the questions in each section in the questionnaire.

Questions can be classified in different ways. According to Oppenheim (1992), questions can be classified into factual and non-factual questions. These types are defined as follow:

- Factual questions are concerned with details such as respondents' job title, the occupation of respondent in the organisation. This type of questions is essential to describe the sample and to classify respondents.

- Non-factual questions are concerned with opinions, beliefs and attitudes. For example, questions relating to the level of satisfaction about performance measurement systems.

Furthermore, questions can be classified into open-ended and closed questions (Saunders et al., 2000). These types are defined as follow:

- Open-ended questions: In these types of questions the researcher does not provide any set of responses. Instead the respondents are free to answer in any way they choose.
- Closed questions: In these types of questions the respondents should make choices among a set of alternatives given by the researcher. They help the respondents to make quick decisions and the researcher to code the information easily. The closed questions can be classified into the following types:
 - List questions: This type offers the respondent a list of responses any of which they can choose. Such questions are useful when the researcher needs to ascertain that the respondent has considered all possible responses.
 - Category questions: This type is designed so that each respondent's answer can fit only one category. Such questions are useful to collect data about attributes.
 - Ranking questions: This type asks the respondents to place things in rank order. Such questions are useful to discover the relative importance to the respondents.
 - Quantity questions: This type asks the respondents the amount of a characteristic and tends to be used to collect behaviour or attribute data.
 - Grid questions: This type enables the researcher to record the responses to two or more similar questions at the same time.
 - Scale questions: This type is often used to collect attitude and beliefs data. The most common approach is the Likert scale in which the researcher asks the respondents how strongly they agree or disagree.

Among these types of questions, several open questions were used in this research in the form of "other please specify". Also, an open question was used in section B (question B3) of the questionnaire (see Appendix A for a copy of the final version of the questionnaire) to obtain information about the number of strategic objectives and measures employed in the balanced scorecard. Open questions were also used in section C, part 1 to obtain information about the type and activities of the business unit. Finally, this type of question was used in section I (questions I1-I4) to obtain information about the respondents and to provide the

respondents with a space to comment on the questionnaire. The reason for using a limited number of open questions is that these questions may discourage busy respondents from replying to the questionnaire (Hussey and Hussey, 1997). The main types of questions used in this research were closed questions. The rationale for this choice is that these types of questions are typically used in quantitative studies employing large-scale surveys (Hair et al., 2003). Three types of closed questions were used in this research. First, list questions were used only in section B (questions B2, B4 and B5). Second, category questions were used in the last section of the questionnaire (questions I5 and I6). Finally, the scale questions were extensively used throughout the questionnaire sections to measure research variables.

The rating scale is frequently used in business research (Sekaran, 2003, p. 199). According to Hussey and Hussey (1997, p. 171), the Likert scale is one of the more frequently used types. They do not need much space and are easy to complete by the respondents. The issue of determining the length of Likert scale is controversial. In this context, Elmore and Beggs (1975) indicated that a five-point scale is just as good as any, and that an increase from five to seven or nine points on a rating scale does not improve the reliability of the ratings (quoted in Sekaran, 2003, p. 199). In the same context, Oppenheim (1992, p. 200) argued that several researchers have used a seven-point scale rather than the usual five points. He also indicated that reliability of Likert scales tends to be good, and the seven-point scale permits a greater range of answers to the respondents. However, the more points the researchers use, the more precision they get on the extent of the agreement or disagreement with a statement (Hair et al., 2003, p. 159). Therefore, seven-point Likert scales were used throughout the questionnaire to provide a greater opportunity to respondents to answer the questionnaire.

6.7.2 Questionnaire layout and flow

Mail surveys can often result in a low response rate and a non-response bias (Hussey and Hussey, 1997). Considerable efforts were made to reduce this problem. Methodology researchers (e.g. Saunders et al., 2000; Sekaran, 2003) have concentrated on the layout and the flow as an essential part of constructing the questionnaire. In this context, researchers suggested several guidelines. For example, Saunders et al. (2000, p. 302) indicated that the layout of the questionnaire should be attractive to encourage the respondents to fill it in and return it. The general rule is to keep questionnaire as short as possible, a good questionnaire should include precise instructions to the respondents, and the questions should be presented

in a logical order. Sekaran (2003) argued that the form of the questions should facilitate the progress of the responses from the start to the end of the questionnaire.

The length of the questionnaire is likely to affect the response rate. Eight A4 pages were used to cover all the research variables. However, this is consistent with Saunders et al. (2000) recommendation, in which they argued that the optimal length of the questionnaire is between six and eight A4 pages. In this research, the first page consisted of the name of the University of Huddersfield followed by the title of the research. The page ended with the name of researcher and his supervisor. In addition, the name, job title and respondents addresses were printed at the top right-hand side of the first page.

Another important issue that should be taken into consideration when designing the questionnaire is the order and flow of questions. The aims of this issue are to make the questionnaire easy to use and to motivate the respondents (Saunders et al., 2000). Several researchers (e.g. Oppenheim, 1992; Saunders et al., 2000) have suggested guidance for the order of the questions. But the final choice of approach and sequence must be determined by the research problems, and by the results of the pilot work (Oppenheim, 1992, p. 112).

Each section of the questionnaire consisted of clear instructions. Thus, the flow of the questions was designed as follows: First, the essential part of the study was placed at the beginning of the questionnaire (i.e. questions about performance measurement systems, practices and the balanced scorecard). Second, questions relating to the independent variables (i.e. organisation type, strategy, structure, environment, competition, and manufacturing practices) were grouped respectively, followed by a separate section about the effectiveness of the current performance measurements. The last section of the questionnaire was designed to obtain general information. A detailed description relating to the flow of the questions is shown in section 6.9.

6.7.3 Questionnaire pre-testing and pilot work

Prior to administering the questionnaire, it was necessary to test and pilot the questions. The purpose of this procedure is to refine the questionnaire so that respondents will have no problems in answering and recording the questions (Oppenheim, 1992). According to Saunders et al. (2000, p. 305), the pre-testing issue enables the researchers to obtain some

assessment of the questions' validity and the likely the reliability of the data. Pre-testing may involve a small number of respondents to test the appropriateness of the questions and their comprehension (Sekaran, 2003). In another context, pre-testing may involve friends, colleagues and people of different opinions (Hussey and Hussey, 1997). Thus, this research took into consideration the aforementioned suggestions and concluded that the best way of testing the questionnaire was based on three stages.

The first stage started by handing the draft questionnaire to five PhD students at Huddersfield University Business School. All the students were undertaking PhD degrees in accounting or business. They provided many insightful comments relating to the wording of questions. Most of their comments were taken into consideration. In the second stage, the questionnaire was handed to three members of academic staff at Huddersfield University Business School/Accountancy Department. Useful comments were received from the academic staff and resulted in changes to the wording and scales of the questions. Moreover, the researcher's supervisor's comments were also taken into consideration. In the final stage of pre-testing, a copy of the questionnaire was e-mailed to two academic researchers in different countries and to the Executive Editor of Balanced Scorecard Collaborative. Useful feedback was received from this group including suggestions for changes to the wording and measurement of some questions related to the balanced scorecard.

For the pilot study, the questionnaire was mailed to 20 companies which were chosen randomly. The questionnaires were addressed to 20 named persons who were asked to participate and complete the questionnaire. In addition, a special covering letter was prepared and mailed to respondents. They were asked to make any comments relating to unclear questions, and suggest questions that they thought would be useful for the research. Furthermore, the pilot study also provided the researcher with the opportunity to examine the coding system that has been used. As a result of the pilot stage, 2 of the 20 questionnaires distributed were returned completed. A reminder letter was sent to those who had not responded to the pilot. As a result of the reminder letter, one questionnaire was returned completed and two were returned uncompleted. The reason given for non-completion was the targeted person was no longer employed by the company. As a (15%) response rate, it was decided not to mail second reminder. The questionnaire responses suggested that the respondents found the questionnaire easy to complete and understandable. Also, there was no evidence to indicate misunderstanding of the questionnaire items. Additionally, the

researcher received two phone calls from a Senior Management Accountant and a Financial Director who apologised for not completing the questionnaire due to company policy not to participate in surveys. However, they indicated that the questionnaire was suitable for meeting the objectives and that the topic was important. Also, they did not suggest any changes regarding the types of questions or the wording.

In response to the comments received from the pre-testing and pilot stage many modifications were made to the questionnaire, but without exceeding the number of pages or deleting important questions. In general, most of these modifications related to wording, layout and improvements in the clarity of the content.

6.8 Features of the covering letter

A well-designed covering letter is needed to accompany the questionnaire. The presentation can encourage respondents to complete the questionnaire correctly. According to Hussey and Hussey (1997), the purpose and context of the questionnaire should be apparent, and this can be achieved by attaching a covering letter, and by starting off the questionnaire with an explanatory paragraph. In this context, Saunders et al. (2000) suggest several guidelines to explain the purpose of the questionnaire by writing an introductory statement accompanied by a covering letter. All of the suggested guidelines were considered to establish a well-designed covering letter.

The covering letter enclosed with the final draft of the questionnaire (see Appendix B) was carefully designed to ensure that the respondents understood the objectives of the study. The letter was printed on a single official letterhead page of Huddersfield University. The first paragraph of the letter consisted of the purpose of the study. The second paragraph emphasised the importance of the study to both companies and the researcher, and also gave the respondents the opportunity to receive a report of the research findings. The third paragraph assured the respondents that all the information would be used only for academic purposes and would be treated as strictly confidential. In addition, the respondents were informed to pass the questionnaire to the appropriate person, if they had been incorrectly identified. The fourth paragraph provided information about the supervisor and the researcher. Finally, a signature was provided demonstrating that the questionnaire was administered personally to the respondent.

6.9 Content of the final draft of the questionnaire

The final draft of the questionnaire (see Appendix A) was designed to include information on the performance measurement diversity, with specific emphasis on factors influencing their effective usage. The questionnaire consisted of eight pages, including the front covering page. The first page included the objectives of the study, and guidance notes to answer the questions. The questionnaire was divided into a nine sections based on the research variables.

Section A (i.e. questions² relating to the performance measurement systems) was divided into three parts. Part one (questions A1-A9) was adapted from Ittner, Larcker and Randall (2003). This part was designed to identify which financial and non-financial performance categories are important drivers of firm's long-term success, based on a 7-point scale ranging from 1 (not at all important) to 7 (extremely important), and the extent to which strategic goals are set for these performance categories on a 7-point scale ranging from 1 (no goals established) to 7 (explicit goals established).

Part two (questions A10-A18) was designed to ascertain the extent to which performance categories are used to evaluate managerial performance, based on a 7-point scale ranging from 1 (not used at all) to 7 (used extensively). These questions were also adapted from Ittner, Larcker and Randall (2003). Also, in this part the respondents were asked on a 7-point scale ranging from 1 (not at all linked) to 7 (extensively linked) to indicate whether these performance categories were linked to financial reward system.

Part three (questions A19-A27) sought to ascertain on a 7-point scale ranging from (extremely poor quality) to 7 (extremely high quality) how well businesses measure information in the performance categories. Also, the respondents were asked on a 7-point scale ranging from 1 (not used at all) to 7 (used extensively) to ascertain the extent to which these categories are used to identify problems, improve opportunities and develop action plans. These questions were adapted from Lingle and Schiemann (1996). Finally, information on how businesses are incorporating performance measures that can be directly linked to the strategies was derived from question A28. Question A29 required the respondents to indicate whether their non-financial performance measures were causally linked to each other and

² The terms questions and items will be used interchangeably in this study to describe the contents of the questionnaire.

also to future financial performance outcomes. These two questions were self-formulated based on a 7-point scale ranging from 1 (not at all) to 7 (to a considerable extent).

Section B focuses on the balanced scorecard (BSC). It was noted that the diffusion of management accounting innovations (e.g. activity-based costing, balanced scorecard) involve several stages ranging from 'not considered' to 'used extensively'. Therefore, question B1 sought to ascertain which of seven potential stages ranging from 1 (not considered) to 7 (used extensively) were applied to the responding businesses. This question was adapted from Krumwiede (1998). The respondents were asked to indicate the perspectives included within their BSC in question B2. Question B3 required the respondents to indicate the number of strategic objectives and the number of performance measures incorporated in the scorecard for each perspective. These two questions were self-formulated. Question B4 was designed to measure the results that businesses have achieved through the use of BSC. The items for this question were adapted from Balanced Scorecard Collaborative Website. The respondents were asked to determine the appropriate levels within their companies where the balanced scorecard has/will be applied. This question was adapted from Speckbacher et al. (2003).

Section C (i.e. questions about the business unit type and activities) was divided into two parts. The first part (questions C1-C3) requested information relating to business unit including size and the business sector within which it was engaged. Part two (questions C4-C10) was adapted from Govindarajan (1988) and Lee and Miller (1996). It focused on the type of business competitive strategy. On a scale ranging from 1 (significantly lower) to 7 (significantly higher), the respondents were asked to indicate the position of their business relative to its leading competitors.

The fourth section of the questionnaire, Section D (questions D1-D9) was adopted from Ramamurthy (1990) and Al-Dahiyate (2003). It focused on the internal operating environment of the businesses. A list of 9 items was provided and the respondents were asked to indicate the most appropriate response relating to the level of centralisation and formalisation on a scale from 1 (strongly disagree) to 7 (strongly agree).

Section E was used to determine the level of perceived environmental uncertainty facing businesses. It was argued in the previous chapter (see Sub-section 5.4.1.3) that there are several streams of research concerning the dimensions of perceived environmental

uncertainty. However, this section (questions E1-E8) was adapted from Govindarajan (1984). The respondents were asked on a scale from 1 (highly predictable rate of change) to 7 (highly unpredictable rate of change) to indicate the predictability of the rate of change within their businesses.

Section F (i.e. questions relating to manufacturing practices) was divided into two parts. The first part (questions F1-F5) sought to measure the implementation of total quality management. Part two (questions F6-F10) requested information relating to the level of implementation of just in time manufacturing approaches. The scale used in this section, was a 7-point scale ranging from 1 (strongly disagree) to 7 (strongly agree). The questions used in this section were adapted from Banker et al. (1993), Monden (1993) and Krumwiede (1998).

Section G (questions G1-G7) was designed to determine the level of competition in the market place. On a 7-point scale ranging from 1 (of negligible intensity) to 7 (extremely intensive) the respondents were asked to indicate the degree of market competition faced by businesses. Questions (G1-G5) were adapted from Guilding and McManus (2002) and questions (G6 and G7) were adapted from Hoque et al. (2001).

Section H was used to measure the effectiveness of the performance measurement systems. It was pointed out in Chapter 5 (see Sub-section 5.4.4) that there are many different ways for measuring organisational effectiveness. However, this section was divided into two parts. The first part sought to determine the level of satisfaction and was adapted from Ittner, Larcker and Randall (2003). On a 7-point scale from 1 (does not meet expectations) to 7 (exceeds expectations) question H1 was designed to determine how well the performance measurement system met expectations. On a 7-point scale ranging from 1 (not at all ideal) to 7 (very close to ideal) the respondents were asked to indicate how well the performance measurement system compares to the concept of an ideal system. Finally, on a 7-point scale ranging from 1 (not at all satisfied) to 7 (completely satisfied), the respondents were asked to indicate their overall satisfaction with the performance measurement system of their businesses. Part two (question H4-H11) was divided into two scales, the first one was designed to measure the importance of eight performance indicators in determining the success of businesses based on a 7-point scale ranging from 1 (not important) to 7 (vitaly important). On a 7-point scale from 1 (poor) to 7 (outstanding), the second scale was designed to determine how well businesses actually performed over the last three years in respect of each of the performance indicators. Also, the respondents were asked in question

H12 to indicate the overall performance of their businesses compared to competitors over the last three years. Questions (H4-H12) were adapted from Govindarajan (1984).

Section I was designed to obtain information about the respondents. Question I1 asked the respondents to insert their job title and position in the organisational structure. Questions (I2-I4) sought to obtain information about the working experience of the respondents and their addresses. Questions (I5-I6) asked the respondents if there was any possibility to arrange a short meeting to discuss their responses and if they wished to receive a copy of the aggregated results of the study.

6.10 The individual respondents

The selection of respondents depends on the characteristics required by the research design (Oppenheim, 1992). It was pointed out in section 6.5 that the researcher made considerable efforts to identify the names and job titles of the targeted respondents in order to ensure that they had a sound knowledge of their performance measurement systems. However, several balanced scorecard studies (e.g. Sandt et al., 2001; Olson and Slater, 2002) have addressed their mail questionnaires to the senior managers as appropriate persons to complete the questionnaire. Other balanced scorecard studies (e.g. Hoque and James, 2000; Maltz et al., 2003) have addressed the questionnaire to the chief financial officers as a well informed people about the performance measurement systems. This research targeted finance directors, financial controllers and senior management accountants because they were likely to be responsible for designing and operating the performance measurement systems in their companies.

6.11 Administering the questionnaire and response profile

The main survey was mailed to 900 participants on January 27, 2004. Each participant was sent a covering letter, questionnaire and a prepaid envelope. The number of usable completed questionnaires was 86. A further 17 were returned uncompleted with reasons for non-completion. After about four weeks, a reminder letter was sent to the respondents. The letter included information about the website created for the questionnaire for the respondents who had misplaced or not received the questionnaire (see Appendix C). This resulted in 51 usable completed questionnaire and 38 were returned uncompleted with specific reasons for not completion.

On March 18, 2004, a second reminder was sent out to respondents to enhance the response rate (see Appendix D). The respondents were asked to indicate if they were not prepared to participate in the survey to complete one section from the questionnaire that was concerned with type of activity of the business, number of employees and annual sales turnover. This information was collected in order to check for the non-response bias (see Section 6.12). As a result, another 57 responses were received including 26 usable questionnaires and 31 unusable questionnaires. For the purpose of non response bias, 96 responses were received including information about business type, number of employees and annual sales turnover.

Consequently, the total usable responses were 163 represents 19.7% response rate³. The response profile of the survey is shown in Table 6.4. According to Saunders et al. (2000, p. 159), examination of recent business surveys reveals response rates as low as 15-20 per cent for postal surveys. Thus, this response rate is considered to be satisfactory as it is equivalent to or higher than response rates in other balanced scorecard studies (e.g. Sandt et al., 2001; Olson and Slater, 2002; Maiga and Jacobs, 2003; Maltz et al., 2003). In a similar vein, a recent survey to investigate the diffusion of management accounting innovation in the UK conducted by Al-Omiri (2003) revealed response rate as 18.9%. Finally, a total of 116 respondents (71%) were interested in receiving a copy of the research findings. Thus, a copy of the preliminary findings was mailed to each respondent with a letter of thanks.

Table 6.4 Survey response profile

Response profile	Main survey	1 st follow-up	2 nd follow-up	Total
Usable questionnaires	86	51	26	163
Non-existence/unreachable	9	28	18	55
Ineligible/non-manufacturing	3	5	7	15
Ineligible/partially completed	2	1	1	4
Refusals/company policy	3	4	5	12
Total	103	89	57	249
Total response rate				27.6%
Usable response rate				19.7%

6.11.1 Characteristics of responding firms

Table 6.5 summarises the main characteristics of responding firms in terms of industry types, number of employees and annual sales turnover. Table 6.5 shows that the responding firms represent a wide range of manufacturing types, and no one industry exceeds 20% of the

³ Response rate = total number of response / total number in sample – (unreachable + ineligible).

sample. In addition, the mean number of employees was 947 and the mean annual sales turnover was £149 million. Therefore, these firms are suitable and represent a good sample to achieve the objectives of this study.

Table 6.5 Characteristics of responding firms

1. Industry type	Frequency	Percent
Plastic products	5	3.0
Textile, cotton, wool, clothing	6	3.7
Aerospace & defence equipment	8	4.9
Food, drinks & tobacco products	34	20.9
Industrial & commercial machinery	10	6.1
Chemicals & pharmaceutical products	14	8.6
Motor vehicles, shipbuilding & motorcycles	8	4.9
Electronics & electrical including IT products	18	11.0
Paper & stationery, cartoons, boxes, packaging	11	6.7
Steel & fabricated metal including medical devices	12	7.4
Domestic products including furniture & electrical pulps	12	7.4
Engineering products including automotive parts, engines	13	8.0
Other products including printing, beauty, media.....	7	4.3
Not responded	5	3.0
Total	163	100

2. Number of employees	Frequency	Percent
201-500 employee	82	50.3
51-100 employee	47	28.9
1001-2000 employee	16	9.8
2001-4000 employee	10	6.1
More than 4000 employee	8	4.9
Not responded	-	-
Total	163	100

3. Annual sales turnover	Frequency	Percent
Less than £5 million	12	7.4
£5 million – less than £100 million	82	50.3
\$ 00 million – less than £200 million	35	21.5
£20 million – £500 million	26	15.9
More than £500 million	8	4.9
Not responded	-	-
Total	163	100

6.11.2 Characteristics of respondents

Table 6.6 shows the main characteristics of respondents in terms of job title, years in current position and working experience. The table shows that 83% of the respondents occupied senior positions in their firms, and 81% of the respondents were concerned with accounting or finance. In addition, they were highly experienced with a mean number of years in their current positions of over 5 years, and a total working experience of over 21 years. Therefore,

the respondents were considered to be knowledgeable and able to provide relevant information about their performance measurement systems.

Table 6.6 Characteristics of respondents

1. Respondents job title	Frequency	Percent
Director of finance	38	23.3
Finance manager	20	12.3
Financial controller	37	22.7
Chief management accountant, senior management accountant, management accountant, management accounting manager	21	12.9
Chief financial officer, chief accountant, corporate accounting manager	4	2.5
Executive manager, director, senior manager, performance reporting manager, partner, commercial planning manager, business planning manager, managing director	15	9.2
Financial accountant, cost accountant, operations accountant, site accountant, accountant	11	6.7
Controlling manager, controller, European controller, cost controller, operations controller	11	6.7
Other including financial analyst, business analyst, senior internal auditor, supply team, international formulation	6	3.7
Not responded	-	-
Total	163	100

2. Experience in current position	Frequency	Percent
Less than 3 years	42	25.8
3 – less than 5 years	46	28.2
5 – less than 10 years	55	33.7
10 – 15 years	18	11.0
More than 15 years	2	1.2
Not responded	-	-
Total	163	100

3. Working experience	Frequency	Percent
Less than 10 years	11	6.7
10 – less than 15 years	21	12.9
15 - less than 20 years	31	19.0
20 - 30 years	79	48.5
More than 30 years	21	12.9
Not responded	-	-
Total	163	100

6.12 Check for non-response bias

It is important at this stage to consider the issue of non-response bias in questionnaire surveys. Non-response is often crucial in a questionnaire survey because research design is dependent on generalising from the sample to the population under investigation (Hussey and Hussey, 1997). Overall, mail questionnaires are capable of being substantially biased by the

presence of a large proportion of respondents who fail to return the questionnaire or those who partially complete the questionnaire (Wallace and Mellor, 1988). As non-response bias could affect the generalisation of the research findings to the population, it was decided to check for non-response bias. Wallace and Mellor (1988, p. 132-133) describe the following methods for checking questionnaire non-response bias:

1. A comparative analysis of responses by date of reply. This analysis requires that returned questionnaires bear the dates of completion, or questionnaires are coded as they are received. One method is to compare the completed questionnaires received from the main survey with those received from the follow-up letter.
2. A comparison of the profile of respondents against known characteristics of a sampled population.
3. A comparison of the characteristics (e.g. geographical location, date of birth, type of qualification) of respondents with non-respondents from the sample.

Apart from various methods to check for non-response bias, the literature does not contain much information about how to choose between these methods. The choice depends on the judgement and experience of the researcher (Wallace and Mellor, 1988, p. 134). In an attempt to ascertain that the research respondents were representative of the group sampled, two alternative methods to compare non-respondents to respondents were employed in this research. The first method was used to compare early respondents (i.e. main survey) and late respondents (i.e. follow-up) in terms of business sector, number of employees and annual sales turnover. If the two groups differ significantly on these terms non-response bias is likely to exist. The second method is to compare the characteristics of respondents with non-respondents from the sample. This information was obtained from the second follow-up letter (see Section 6.11).

Chi-square and Mann-Whitney tests were used to determine if there was a significant difference between early and late respondents and between respondents and non-respondents. The results of these tests are reported in Tables 6.7 - 6.10. The results indicated that there were no significant differences in the responses between these two groups (P -value > 0.05). The results therefore suggest that the limitation of a non-response bias is unlikely to apply in this study.

Table 6.7 Chi-square test comparing industry type between early and late respondents

Chi-Square Tests

	Value	df	Asymp. Sig. (2-sided)
Pearson Chi-Square	9.936	12	.622
Likelihood Ratio	10.292	12	.590
Linear-by-Linear Association	.471	1	.493
N of Valid Cases	158		

Table 6.8 Mann-Whitney test comparing size between early and late respondents

Ranks

	before-after reminder	N	Mean Rank	Sum of Ranks
number of employees	Before reminder	86	84.42	7260.50
	After reminder	77	79.29	6105.50
	Total	163		
sales turnover	Before reminder	86	76.47	6576.50
	After reminder	77	88.18	6789.50
	Total	163		

Test Statistics^a

	number of employees	sales turnover
Mann-Whitney U	3102.500	2835.500
Wilcoxon W	6105.500	6576.500
Z	-.769	-1.626
Asymp. Sig. (2-tailed)	.442	.104

a. Grouping Variable: before-after reminder

Table 6.9 Chi-square test comparing industry type between respondents and non-respondents

Chi-Square Tests

	Value	df	Asymp. Sig. (2-sided)
Pearson Chi-Square	8.240	12	.766
Likelihood Ratio	8.540	12	.742
Linear-by-Linear Association	.064	1	.800
N of Valid Cases	254		

Table 6.10 Mann-Whitney test comparing size between respondents and non-respondents

Ranks				
	respondent-non	N	Mean Rank	Sum of Ranks
number of employees	Respondent	163	133.69	21791.00
	Non	96	123.74	11879.00
	Total	259		
sales turnover	Respondent	163	136.33	22222.00
	Non	96	119.25	11448.00
	Total	259		

Test Statistics^a		
	number of employees	sales turnover
Mann-Whitney U	7223.000	6792.000
Wilcoxon W	11879.000	11448.000
Z	-1.168	-1.817
Asymp. Sig. (2-tailed)	.243	.069

a. Grouping Variable: respondent-non

6.13 Validity and reliability

It is important at this stage to examine the accuracy and precision of the instrument used to measure the research variables. Thus, validity and reliability measurements were established to ensure that the measures developed are reasonably good (Sekaran, 2003). Validity refers to the degree to which an instrument measures what it is supposed or intended to measure, whereas reliability refers to how well the instrument of interest is measured (Oppenheim, 1992).

6.13.1 Validity

Several types of validity tests are identified. Criterion, content and construct validity are usually used to assess measurement validity (Hair et al., 2003). Criterion validity assesses whether a construct performs as expected relative to other variables identified as meaningful criteria (Hair et al., 2003, p. 175). Two terms of criterion validity can be performed. The first is concurrent validity, which refers to the extent to which a measurement scale relates to other well-validated measures of the same topic (Oppenheim, 1992). It is established when the results obtained from the scale used are consistent with the results of other scales that are used to measure the same object (Oppenheim, 1992, p. 162). The second is predictive validity, which refers to the ability of the measuring instrument to differentiate among individuals with reference to a future criterion (Sekaran, 2003, p. 207).

The second type of validity is content validity. It ensures that the measurement scale includes an adequate and representative set of items that represent the concept (Sekaran, 2003). Content validity can be determined by a careful definition of the research topic, and the items included in the measurement scale (Cooper and Schindler, 2001). In addition, a group of experts can comment and judge on the suitability of the questionnaire, as well as allowing suggestions to be made to the structure of the questionnaire (Saunders et al., 2000, p. 306). In this study, several efforts were made to meet content validity. First, the purpose of the study was identified through an extensive literature review. Second, many questions and scales were used from previous studies. Third, the questionnaire was pre-tested by members of staff, doctoral students and a panel of academic researchers. Finally, a pilot study was undertaken to ensure that respondents have had no problems answering questions (see Sub-section 6.7.3).

The third and final type of validity is construct validity. It refers to how well the results obtained from the measurement scale fit the theories around which the test is designed (Sekaran, 2003). Pre-testing the questionnaire in order to get a feedback can assess this type of validity. As mentioned earlier, this study has carried out a number of pre-testing stages and pilot work to enhance construct validity. In addition, the measurement model analysis in structural equation modelling (SEM) is utilised to assess the construct validity. Specifying and validating the measurement model involves several stages including assessing content validity, unidimensionality, convergent validity, discriminate validity and reliability (Hair et al., 1998). Unidimensionality refers to the characteristics of a set of indicators that has only one underlying concept in common (Hair et al., 1998, p. 584). When using multiple item questions, it is imperative to assess the degree to which items represent only one variable. Convergent validity is assessed when the scores obtained with two different instruments measuring the same concept are highly correlated. Discriminant validity is established when, based on theory, two variables are predicted to be uncorrelated and the scores obtained by measuring them are empirically found to be so (Sekaran, 2003, p. 207). In this study, unidimensionality, convergent validity and discriminant validity were assessed through the use of exploratory factor analysis (EFA) in which all factor loadings were of an adequate extent to confirm the dimensions of the concepts, and also through the use of confirmatory factor analysis (CFA) in which goodness of measurement model fit using SEM is the criterion. All results of both exploratory and confirmatory factor analysis are presented in Chapter 8.

6.13.2 Reliability

The reliability of a measure refers to the extent to which it is without bias (error free) and hence ensures consistent measurement across time and across the various items in the instrument (Sekaran, 2003, p. 203). The reliability of a measure is an indication about the stability and consistency of a measure over time (Easterby-Smith, 2002). According to Sekaran (2003, p. 204-205), test-retest reliability and parallel-form reliability are two tests of stability of measures and inter-item consistency reliability and split-half reliability are two tests of internal consistency of measures. In this study, the Cronbach alpha measure of internal consistency was used to assess the overall reliability of the measurement scale. This measure is the most frequently used method for calculating internal consistency (Saunders et al., 2000, p. 307). The recommended minimum acceptable level of reliability for Cronbach alpha is .60 using Hair et al. (1998) criterion and greater than .50 using Nunnally's (1978) criterion. The results show that all the variables passed the test and the achieved values exceed the recommended value of this test (see Chapter 8).

6.14 Statistical methods used in data analysis

The analysis and interpretation of any data depend on the objectives of the study and the nature of data (Hussey and Hussey, 1997). As mentioned earlier in this chapter the decision was made to adopt the quantitative approach to meet the objectives of the research and to test its model. It is widely recognised that determining the appropriate statistical methods to analyse data depend mainly on meeting the assumptions of parametric tests. These assumptions according to Field (2000, p. 37-38) and Bryman and Cramer (2001, p. 115) are:

1. The scale of measurement is of equal interval or ratio scaling, that is, more than ordinal.
2. The data are from a normally distributed population.
3. The variances should not change systematically throughout the data.

Several arguments were forwarded by researchers about using parametric or non-parametric tests. However, the need to meet the aforementioned assumptions for using parametric tests has been strongly questioned (Bryman and Cramer, 2001). As far as the first assumption is concerned, data in this research were collected using the ordinal scale and parametric tests are applied to such scales. In this context, Bryman and Cramer (2001, p. 115) state that

It has been suggested that parametric tests can also be used with ordinal variables since tests apply to numbers and not to what those numbers signify (for example, Lord, 1953). Thus, for example, we apply these tests to determine if two scores differ. We know what these scores indicate, but the test obviously does not. Therefore, the data are treated as if they are of interval or ratio scaling.

Recently, however, Hair et al. (2003, p. 157) advocate that in business research, it is appropriate to treat the ordinal scale as if it were interval. Furthermore, parametric tests have been used with ordinal variables and reported in the published management accounting research journals, and have been also used in previous balanced scorecard research (e.g. Hoque and James, 2000; Ittner, Larcker and Randall, 2003). In addition, all the research variables were normally distributed (see Chapter 8, section 8.3). Therefore, it was decided to use parametric tests for testing the research hypotheses.

A decision was also made to utilise a number of statistical methods in analysing the data: descriptive statistics (i.e. frequency and mean), exploratory factor analysis, correlation and multiple regression and structural equation modelling. The rationale for using these statistical methods is presented in the following sub-sections. More detailed explanations of some of the items in the following sub-sections will be provided in Chapters 7-9. In addition, the content of the following sub-sections will be drawn off to interpret and explain the statistical findings presented in the subsequent chapters.

6.14.1 Descriptive statistics

Descriptive statistical methods are concerned with describing, presenting and summarising data (Hussey and Hussey, 1997). Frequencies and means were used earlier to describe the characteristics of the responding firms and the individual respondents. In addition, frequencies, means and mean differences are used to interpret the outputs from the descriptive statistics. For example, frequencies are used in ranking the level of balanced scorecard usage. Moreover, the means are also used to describe the types of non-financial performance measurements according to their importance in performance measurement and evaluation purposes. Descriptive statistics provides an indication about the shape of the sample distribution which helps in deciding the appropriate analytical statistical method that may be used to test the research hypotheses.

6.14.2 Exploratory factor analysis (EFA)

Factor analysis is a generic concept given to a class of multivariate statistical methods whose primary aim is to define the structure in a data matrix (Hair et al., 1998). It addresses the problem of analysing the structure of the interrelationships among a number of variables by defining a set of common underlying dimensions, known as factors (Hair et al., 1998, p. 90). The purposes of this technique are to assess the degree to which items measuring specific variables are tapping the same concept and to determine the degree to which variables can be reduced to a smaller set (Field, 2000). EFA was utilised to define the dimensions of the contingent variables in order to identify the pattern of relationships between these variables and the factors. The results and decision rules of EFA are presented in Chapter 8. The rationale behind utilising this technique is due to the way previous researchers have defined and measured the contingent variables in their studies. Many of the variables used are theoretical concepts that are not capable of direct measurement such as perceived environmental uncertainty, organisational structure and business strategy (Ittner and Larcker, 2001). In addition, many of these studies simply conduct a reliability test for the contingent variables without conducting any statistical analysis to ascertain whether the items used can be aggregated into a single or more than one variable.

6.14.3 Structural equation modelling (SEM)

Structural equation modelling (SEM) is a comprehensive statistical approach for testing hypotheses about the relationships among observed and latent variables (Hoyle, 1995, p. 1). SEM has become a useful statistical approach to test the relationships among a set of substantive variables simultaneously (Hair et al., 1998). It is also known by a variety of several names such as covariance structure analysis, latent variable modelling, or causal modelling (Crowley and Fan, 1997, p. 508). According to Hair et al. (1998, p. 584):

All SEM techniques are distinguished by two characteristics: (1) estimation of multiple and interrelated dependence relationships, and (2) the ability to represent unobserved concepts in these relationships and account for measurement error⁴ in the estimation process.

SEM consists of a measurement model and structural model (Hair et al., 1998). The measurement model defines relations between observed variables and unobserved

⁴ Measurement error is the degree to which the variables we can measure (the manifest variables) do not perfectly describe the latent construct(s) of interest (Hair et al., 1998, p. 581).

hypothetical constructs known as ‘latent variables’ (Byrne, 1995). This can be achieved by utilising confirmatory factor analysis (CFA) to establish the loading of each measured variable on the latent variable. CFA is particularly useful in the validation of scales for the measurement of specific constructs (Hair et al., 1998). The structural model is a set of one or more dependence relationships linking the hypothesised model’s constructs (Hair et al., 1998, p. 583). General CFA models are forms of path models that hypothesise relationships between unmeasured constructs and observed measures (Maruyama, 1998, p. 139). According to Hoyle (1995, p. 13-15), the SEM approach share several similarities with other multivariate data analysis approaches (e.g. correlation, multiple regression and ANOVA). Indeed, SEM differs from these approaches in other important ways. Table 6.11 summarises the main similarities and differences between SEM and other multivariate data analysis based on the basic concepts and issues highlighted by Hoyle (1995).

Table 6.11 Differences and similarities between structural equation modelling and standard approaches

Differences	Structural equation modelling approach	Standard approaches (correlation, ANOVA, multiple regression)
	<ul style="list-style-type: none"> • Requires formal specification of a model to be estimated and tested. 	<ul style="list-style-type: none"> • Do not require specification, while multiple regression permits to specify the direct effects on a single outcome.
	<ul style="list-style-type: none"> • SEM has the capacity to estimate and test relations between latent variables and this would increase the probability of detecting association and obtaining estimates of free parameters close to their population values. 	<ul style="list-style-type: none"> • The standard approaches do not have the capacity to estimate and test relations between latent variables.
	<ul style="list-style-type: none"> • SEM uses ambiguous tests (e.g. the complex effect of data and model characteristics on the X^2). 	<ul style="list-style-type: none"> • The standard approaches use relatively straightforward tests.
Similarities	<ul style="list-style-type: none"> • Both approaches are based on linear statistical models. • Both approaches do not offer statistical tests of causality. • Statistical tests associated for both approaches are valid if certain assumptions about the observed data are met (e.g. multivariate normality). • Adjustments to statistical hypotheses tested by both approaches increase the likelihood of sample-specific results. 	

For the purpose of explaining the SEM, it is useful to identify the variables in the system. Observed variables are simply variables that are directly measured (MacCallum, 1995), while, latent variables are unobserved variables implied by the covariances among two or more indicators (Hoyle, 1995, p. 3). An exogenous variable is one that does not receive a directional influence from any other variable in the system whereas an endogenous variable is one that receives a directional influence from some other variables in the system (MacCallum, 1995, p. 17). In addition, it is useful to explain the features of path diagrams that represent the structural equation model. According to (Hoyle, 1995, p. 11), the primary components of a path diagram are:

- Rectangles are used to indicate observed variables, which may be either indicators of latent variables in the measurement model or independent or dependent variables in the structural model.
- Ellipses are used to indicate latent variables, independent and dependent variables as well as errors of prediction in the structural model and errors of measurement in the measurement model.
- Arrows are used to indicate association between variables. These are in two types, first straight arrows that show a directional relationship (the regression coefficient), and second curved arrows point in two directions and indicate a non-directional association (i.e. correlation).

In addition, it should be noted that two types of arrows labelled E and D are accompanied with the endogenous variable. E represents error term related to the observed variable, and D represents residual or disturbance which shows that part of the endogenous variable that is not accounted for by the linear influences of the other variables in the equation⁵ (MacCallum, 1995, p. 19). However, SEM applications involve several steps⁶ including:

1. Model specification refers to the initial theoretical model and the pattern of relationships among the variables.
2. Identification refers to the ability of the model to generate estimates. This step is concerned with the free parameters that can be obtained from the observed data (if for each free parameter a value can be obtained through one manipulation of the observed data, then the model is just identified and has zero degrees of freedom).
3. Estimation refers to the estimation techniques that are used in SEM. According to Hair et al. (1998), maximum likelihood estimation (MLE) is the most commonly used technique when the assumption of multivariate normality is met and with small sample sizes. Other techniques include weighted least squares (WLS), generalised least squares (GLS), and asymptotically distribution free (ADF) are also used when the assumption of multivariate normality is not met.
4. Testing fit involves interpreting model fit or comparing fit indices to determine if the data fit the theoretical model.

⁵ Labels E and D can be viewed as consisting partly of random error and partly of systematic error that is not explained, but could theoretically be explained by variables or effects not included in the model (MacCallum, 1995, p. 19).

⁶ For an extensive discussions on SEM application steps, see Schumacker and Lomax (1996, p. 77-137).

Several researchers (e.g. Hoyle, 1995; Chau, 1997; Hair et al., 1998) recommended a set of fit indices to evaluate the model goodness-of-fit in SEM rather than single index. Table 6.12 presents the recommended values of goodness-of-fit measures provided by the EQS⁷ as suggested in the literature. However, poor goodness-of-fit requires the last step in SEM applications (i.e. modification), which include adding, deleting, or modifying the paths in the model. The various measures of model goodness-of-fit and their recommended values listed in Table 6.12 are used in this research.

Table 6.12 Recommended values of goodness-of-fit measures. Source: Adapted from Chau (1997), p. 318

Goodness-of-fit measures	Recommended values
Chi-square	$P \geq .05$
Goodness-of-fit index (GFI)	≥ 0.90
Adjusted goodness-of-fit index (AGFI)	≥ 0.80
Normed fit index (NFI)	≥ 0.90
Comparative fit index (CFI)	≥ 0.90
Non-normed fit index (NNFI)	≥ 0.90
Root mean square error of approximation (RMSEA)	< 0.10

Finally, it should be noted that some SEM programs (e.g. EQS) have been written to handle ordinal and categorical variables (Schumacker and Lomax, 1996). In addition, several studies have called for greater use of SEM in business in different fields including marketing, operations management and accounting (e.g. Crowley and Fan, 1997; Smith and Langfield-Smith, 2002). Recent studies (e.g. Ittner and Larcker, 2001; Chenhall, 2003) have also paid attention towards using SEM in management accounting research to control for measurement error since it requires researchers to specify measurement and structural relationships.

6.14.4 Correlation and multiple regression

Correlation and multiple regression are used since all of the research variables are measured on an ordinal and interval scale, also the dependent variable is a metric. The correlation analysis is used to describe the strength and direction of the relationship between two variables (Pallant, 2001). In order to judge the strength of the relationship between the variables, Bryman and Cramer (2001, p. 174) cited from Cohen and Holliday (1982) suggest the following: 0.19 and below is very low; 0.20 to 0.39 is low; 0.40 to 0.69 is modest; 0.70 to 0.89 is high; and 0.90 to 1 is very high. In contrast, Cohen (1988) suggested that a value of approximately 0.10 represents a small correlation, 0.30 a medium correlation and 0.50 or

⁷ EQS is one of the structural equation modelling computer programs. For more complete discussion on EQS see Sub-section 8.4.2.

more represents a large correlation. However, this analysis shows that if variables are related, but it does not determine which of these variables is the independent one and the dependent one. In this context, Field (2000, p. 103) indicated that correlation is a very useful research tool but it does not provide information about the predictive power of the variables. In contrast, multiple regression technique complements the correlation analysis by identifying the dependent and independent variables. They are also appropriate for identifying the impact of independent variables on the dependent variable. Finally, it should be noted that these statistical techniques have been frequently used in management accounting research and balanced scorecard studies (e.g. Ittner, Larcker and Randall, 2003).

6.15 Summary

The processes of conducting a research project have been explained and discussed in this chapter. The research philosophy and design were explained and the differences between research paradigms and methodologies were discussed. The positivistic paradigm employing a cross-sectional survey methodology was utilised as an appropriate method for conducting this research. The research population, sampling frame and data collection methods were also discussed in this chapter, followed by a justification for selecting large manufacturing companies operating in the UK. Specifically, the sampling frame was based on the FAME database and consisted of 2048 manufacturing companies that achieved a sales turnover of more than £50 million. The CIMA database was also utilised to identify the names and job-titles of the targeted respondents. A random sample of 900 companies operating in various manufacturing sectors was chosen and the mail questionnaire method was employed as the most appropriate method to collect a large amount of data.

Specific design methods were used in constructing the questionnaire. Several steps were employed for evaluating and testing the questionnaire and, in addition, pilot work was conducted. A total of 163 usable questionnaires were received, representing a 19.7% response rate. This was considered satisfactory for conducting the statistical analysis. Two alternative methods of testing for non-response bias were employed in this research. However, no significant differences were found in the two tests, suggesting that the limitation of a non-response bias is unlikely to apply. The issues of reliability and validity were also discussed in this chapter. Finally, a description was provided of the statistical methods utilised in this research.

Chapter 7

A description of the research findings

7.1	Introduction.....	7-2
7.2	The importance of performance categories to long-term organisational success and their use in performance measurements and evaluation.....	7-2
	7.2.1 Importance to long-term organisational success.....	7-2
	7.2.2 Setting strategic goals.....	7-4
	7.2.3 Managerial performance evaluation.....	7-6
	7.2.4 Financial reward system.....	7-7
	7.2.5 Measurement quality.....	7-8
	7.2.6 Problem identification.....	7-9
7.3	Performance measurement gap.....	7-10
7.4	Performance measurements used by business units.....	7-14
	7.4.1 Linking performance measures to strategies.....	7-16
	7.4.2 The link between performance measures.....	7-17
7.5	State of balanced scorecard implementation.....	7-19
	7.5.1 Type of balanced scorecard perspectives.....	7-20
	7.5.2 Number of strategic objectives and measures used in the balanced scorecard.....	7-23
	7.5.3 Balanced scorecard components.....	7-25
	7.5.4 Results of balanced scorecard implementation.....	7-26
	7.5.5 Level of balanced scorecard implementation.....	7-27
7.6	Mean differences between balanced scorecard users and non-users.....	7-28
7.7	Respondents' satisfaction with performance measurement systems.....	7-31
7.8	Summary.....	7-32

Chapter 7

A description of the research findings

7.1 Introduction

This chapter aims to present and discuss the results of the descriptive statistics relating to the first and fourth objectives of this research (see Chapter 5, section 5.3). This chapter is structured as follows: Section 7.2 provides a description of the importance of performance categories to long-term organisational success and their use in performance measurements and evaluation. Section 7.3 focuses on the performance measurement gap identified in this study. The descriptive findings concerning the respondents' views on the degree of usage of both financial and non-financial performance measures and the types of non-financial performance measures that are used in this industry are presented in section 7.4. In section 7.5 the findings relating to the state of balanced scorecard (BSC) implementation (i.e. types of perspectives, number of perspectives, number of strategic objectives and measures, BSC components, results of BSC implementation and the level of implementation) are presented. The differences between BSC users and non-users are presented in section 7.6. This is followed by section 7.7, which presents the respondents' satisfaction with their performance measurement systems. Finally, the chapter summary is presented in section 7.8.

7.2 The importance of performance categories to long-term organisational success and their use in performance measurements and evaluation

All of the respondents (N = 163) answered the three parts of section A of the questionnaire, thus indicating that they operated performance measurement systems, in terms of financial and non-financial performance measures. These measures are represented by financial, customer, operational, innovation, employee, supplier, environment, quality and community performance categories. Descending means and frequencies were used to examine the importance of financial and non-financial performance categories to long-term organisational success, and their use in performance measurements and evaluation. Based on a seven-point scale, the descriptive analysis and the discussion are presented in the following sub-sections.

7.2.1 Importance to long-term organisational success

The respondents were asked in section A (questions A1i-A9i) to indicate the importance of financial and non-financial performance categories as drivers of long-term organisational

success. Table 7.1 shows the descending means and the relative weight placed on these performance categories, which reflects the importance of each of them as a driver of long-term organisational success.

Table 7.1 Descending means and the relative weight placed on performance categories as drivers of long-term organisational success

Performance categories	Mean	Standard deviation	% rating 1, 2 or 3	% rating 4	% rating 5, 6 or 7
Financial	6.49	0.819	0.6	3.1	96.3
Customer	6.26	0.850	1.2	0.6	98.1
Quality	5.86	1.042	2.4	7.4	90.2
Operational	5.64	1.022	1.8	11.0	87.1
Innovation	5.19	1.279	9.2	19.6	71.2
Supplier	5.02	1.298	14.1	14.7	71.1
Employee	4.96	1.113	11.0	21.5	67.4
Environment	4.46	1.488	23.4	25.2	51.5
Community	3.75	1.504	39.3	28.2	32.6

The above table shows that financial performance category (mean = 6.49), which refers to monetary metrics (e.g. annual earnings, ROA) was ranked as the most important performance category. This result indicates that the respondents still perceive the financial information as an important source of information to achieve organisational objectives, and thus enhancing organisational strategy. Thus, managers are still depending primarily on financial metrics to evaluate long-term performance not only because of their effect on the monetary success of organisations, but also for their importance as a source of information about financial transactions and the internal activities.

Non-financial performance categories relating to customer, quality and operational were ranked as the most important non-financial performance measures (mean ranging from 5.64 to 6.26). In addition, innovation, supplier, employee and environment performance categories also occupy significant importance (mean ranging from 4.46 to 5.19). Their widespread use suggests that managers feel that their organisations have been able to clearly define what the organisation hopes to accomplish in these areas. In addition to financial information, management requires accurate performance information on its customers, markets, competitive position and operational performance (Bititci et al., 2002). Thus, it can be concluded that these non-financial performance categories play a major role as value drivers, leading organisations to cope with the high level of competition and to achieve their strategic objectives.

Table 7.1 suggests that the community performance category falls on the unimportant/moderately important borderline (mean = 3.75). This suggests that managers in the manufacturing companies generally consider that performance measures within the community category to be the least important drivers of their strategic progress and success. In contrast, in the financial services industry, Ittner, Larcker and Randall (2003) reported that the community performance category received relatively high importance as a driver of long-term organisational success.

In general, the aforementioned results are clearly in line with the increasing importance of including non-financial performance measures in the performance measurement systems. In this context, Ittner and Larcker (1998a, p. 218) argued that the substantial changes in the nature and intensity of competition have forced firms to determine and measure the non-financial 'value drivers' leading to success in the new competitive environment. Empirically, a study conducted by CIMA (1993) reported that manufacturing companies adopt financial and non-financial performance measures because they indicate the right direction for meeting changes in the manufacturing environment. In these situations, top management need to be able to identify those processes and activities that are likely to generate value over the long term (Cumby and Conrod, 2001, p. 261-262).

Thus, it can be noted that manufacturing companies have paid attention to the importance of financial and non-financial performance categories as drivers of long-term organisational success. This result supports the idea suggested by several researchers (e.g. Kaplan, 1984; Guenther and Gruening, 2002), in which they indicated that companies should include both financial and non-financial performance measures in their performance measurement systems as drivers of the long-term success.

7.2.2 Setting strategic goals

The respondents were asked in section A (questions A1ii-A9ii) to indicate the extent to which strategic goals are set for each of the nine performance categories. Table 7.2 shows the descending means and the relative weights placed on setting strategic goals for the performance categories.

Table 7.2 Descending means and the relative weight placed on setting strategic goals to performance categories

Performance categories	Mean	Standard deviation	% rating 1, 2 or 3	% rating 4	% rating 5, 6 or 7
Financial	6.26	1.010	2.4	2.5	95.1
Quality	5.43	1.370	10.4	9.2	80.4
Customer	5.39	1.224	7.4	14.1	78.5
Operational	5.22	1.406	10.4	17.2	72.4
Innovation	4.52	1.577	25.2	24.5	50.3
Supplier	4.17	1.623	38.0	15.3	46.6
Employee	4.11	1.457	33.1	28.2	38.6
Environment	3.90	1.799	40.5	17.8	41.7
Community	3.01	1.511	61.3	22.1	16.5

The above results indicate that the responding companies still perceive financial performance as an important measure to evaluate performance by establishing explicit strategic goals with a mean of 6.26. In terms of non-financial performance, quality, customer, operational, innovation, supplier and employee performance categories occupy considerable importance in the respondents' view with a mean ranging from 4.11 to 5.43. Thus, the respondents generally agree with the idea of setting strategic goals for these non-financial performance categories.

The aforementioned results can be interpreted by comparing them to the responses obtained in sub-section 7.2.1. The rankings in terms of Tables 7.1 and 7.2 are virtually identical. Also apart from the environment performance category, strategic goals are set for all those performance categories that are identified as important drivers of long-term organisational success. This suggests that managers are able to define clearly what their companies hope to accomplish in the areas of financial, customer, operational, quality, innovation, employee and supplier performance. Thus, they can establish strategic goals for these performance categories. However, for the environment and community performance categories, it appears that considerably less emphasis is given to establishing strategic goals. The findings presented in Tables 7.1 and 7.2 suggest that there is a strong relationship between the tendency to set explicit strategic goals, and the importance of the performance measures to the long-term success of the business. The results are consistent with Otley's (1999) argument of establishing targets and setting strategic goals for both financial and non-financial performance measures.

7.2.3 Managerial performance evaluation

The respondents were asked in section A (questions A10i-A18i) to indicate the extent to which financial and non-financial performance categories are used to evaluate managerial performance. Table 7.3 shows the descending means and the relative weight placed on these performance categories, which reflects the use of each of them to evaluate managerial performance.

Table 7.3 Descending means and the relative weight placed on performance categories to evaluate managerial performance

Performance categories	Mean	Standard deviation	% rating 1, 2 or 3	% rating 4	% rating 5, 6 or 7
Financial	5.98	1.307	6.7	3.1	90.2
Operational	5.32	1.265	7.9	16.0	76.2
Quality	5.00	1.432	11.7	24.5	63.8
Customer	4.85	1.481	16.6	19.0	64.4
Supplier	3.83	1.638	46.6	17.2	36.2
Innovation	3.82	1.640	40.5	25.2	34.3
Employee	3.72	1.354	44.8	23.3	31.9
Environment	3.06	1.586	62.0	17.8	20.2
Community	2.34	1.381	78.5	12.3	9.2

It can be noted from the above table that the responding companies are still depending on financial information as the main source to evaluate managerial performance with a mean of 5.98. In addition, the respondents indicated that non-financial information relating to the operational, quality and customer performance categories tend to be used to a significant extent (with a mean ranging from 4.85 to 5.32) to evaluate the managerial performance. In contrast, supplier, innovation, employee, environment and community performance categories tend not to be significantly used (with a mean ranging from 2.34 to 3.83) for managerial performance evaluation.

The aforementioned results can be interpreted by comparing them to the responses obtained in sub-section 7.2.2. They show that strategic goals are highly established for the financial, operational, quality and customer performance categories. These categories are found to be the only performance categories that are moderately/extensively used to evaluate managerial performance. This suggests that the responding companies extensively set targets for financial, operational, quality and customer performance categories. Thus, the respondents agree with the idea of placing greater emphasis on using the same performance categories to evaluate managerial performance. This result is similar to the ideas suggested by several researchers (e.g. Chenhall and Morris, 1986; Otley, 1999) in which they indicated that targets

should be set for both financial and non-financial performance measures in order to evaluate managerial performance.

7.2.4 Financial reward system

The respondents were asked in section A (questions A10ii-A18ii) to indicate the extent to which their companies use each of the nine performance categories in their financial reward system. Table 7.4 shows the descending means and the relative weight placed on linking performance categories to financial reward system.

Table 7.4 Descending means and the relative weight placed on linking performance categories to financial reward system

Performance categories	Mean	Standard deviation	% rating 1, 2 or 3	% rating 4	% rating 5, 6 or 7
Financial	5.64	1.651	11.1	9.8	79.2
Operational	4.01	1.832	38.7	18.4	42.9
Customer	3.87	1.877	42.9	14.1	43.0
Quality	3.56	1.846	45.3	19.0	35.7
Innovation	2.89	1.644	64.4	20.2	15.4
Supplier	2.69	1.627	73.0	8.6	18.4
Employee	2.65	1.476	72.4	16.0	11.6
Environment	2.31	1.407	80.4	11.0	8.6
Community	2.01	1.324	84.7	9.2	6.1

The above table shows that the financial performance category is the most important category used to reward managers with a mean of 5.64. In terms of non-financial performance categories, the results show that the operational performance (mean = 4.01) category is the only non-financial category that is significantly used to reward managers. The results also show that on average customer, quality, innovation, supplier, employee, environment and community performance categories tend not to be linked to the financial rewards system in their business units.

These results suggest that the responding companies are still depending mainly on the financial performance information as the main source to reward managers in terms of managerial compensation. Despite the increasing use of non-financial performance measures in managerial compensation (Ittner et al., 1997), only operational performance measures appear to be moderately used to reward managers. Empirically, these results are very similar to Stivers et al. (1998), who reported that only financial and operational performance measures were linked to compensation. Thus, it can be concluded that the responding companies are still depending on traditional financial performance measures as the

predominant measure to reward managers. The findings do not therefore support the recommendations suggested by several researchers (e.g. Rappaport, 1999; Banker et al., 2000) to link the non-financial performance measures with executive compensation plans.

7.2.5 Measurement quality

The respondents were asked in section A (questions A19i-A27i) to indicate how well their companies measure performance in the nine performance categories. Table 7.5 shows the descending means relating to the respondents' perceptions of how well their business units measure performance (i.e. measurement quality) within each performance category.

Table 7.5 Descending means in relation to measurement quality within each performance category

Performance categories	Mean	Standard deviation	% rating 1, 2 or 3	% rating 4	% rating 5, 6 or 7
Financial	6.01	0.920	1.8	4.3	93.9
Quality	5.48	1.214	8.0	9.8	82.2
Operational	5.44	1.176	5.5	13.5	81.0
Customer	5.00	1.277	12.3	19.6	68.1
Employee	4.34	1.238	25.7	28.8	45.5
Supplier	4.33	1.598	32.0	16.6	51.4
Innovation	3.87	1.442	40.5	23.3	36.2
Environment	3.72	1.596	44.2	23.3	32.5
Community	2.56	1.301	74.8	18.4	6.8

It can be noted from the above table that respondents consider that measurement quality is high (with a mean of 6.01) in respect of the financial performance category. This may provide a partial explanation as to why the responding companies are still depending on financial information as the main source of information to compete and base strategic decisions. The results also show that their companies consider the quality of information to be sufficient in respect of quality, operational and customer performance measures with a mean ranging from 4.33 to 5.48. This suggests that information about customer, internal operations and quality are valued by the responding companies as an important source of information to face competitive marketplaces. In addition, companies depend moderately on employee and supplier performance to measure information. Thus, it can be concluded that the respondents agreed on the ability of financial and non-financial performance indicators within these categories to provide accurate and meaningful measures. This result is consistent with the argument raised by several researchers (e.g. Chenhall and Morris, 1986; Ittner and Larcker, 2001) to include non-financial performance measures in the performance measurement systems in order to provide information that reflects the attributes of these

indicators. This is also similar to the results reported by the empirical work of Lingle and Schiemann (1996).

7.2.6 Problem identification

The respondents were asked in section A (questions A19ii-A27ii) to indicate the extent to which their companies use each of the nine performance categories for identifying problems and improvement opportunities and developing action plans. Table 7.6 shows the descending means and the relative weight placed on these performance categories to identify problems and improvement opportunities and developing action plans.

Table 7.6 Descending means and the relative weight placed on performance categories to identify problems and improvement opportunities and developing action plans

Performance categories	Mean	Standard deviation	% rating 1, 2 or 3	% rating 4	% rating 5, 6 or 7
Financial	5.97	0.984	2.4	6.1	91.5
Operational	5.63	1.232	6.8	8.0	85.3
Quality	5.52	1.326	8.0	11.0	81.0
Customer	5.11	1.333	12.9	16.0	71.1
Supplier	4.29	1.673	36.2	14.1	49.7
Employee	4.01	1.444	38.1	25.8	36.1
Innovation	3.73	1.564	43.5	22.1	34.4
Environment	3.36	1.673	53.4	19.0	27.6
Community	2.44	1.383	75.5	16.6	7.9

The above table shows that the financial performance category (with a mean of 5.97) is the most important category that is used to identify problems and improvement opportunities and developing action plans. In terms of non-financial performance categories, the results show that operational and quality performance are used significantly to identify problems and improvement opportunities and developing action plans with means of 5.63 and 5.52 respectively. Customer, supplier and employee are also used to a moderate extent in problem identification with means ranging from 4.01 to 5.11. In contrast, innovation, environment and community tend to be not used in problem identification with means ranging from 2.44 to 3.73.

The aforementioned results can be interpreted by comparing them to the responses obtained in sub-section 7.2.5. This shows that the same performance categories (i.e. financial, quality, operational, customer, employee and supplier categories) that achieved high measurement quality were also used to identify problems and improvement opportunities and developing action plans. This indicates that when respondents consider that information quality is high

they are more likely to use this information for identifying problems and improvement opportunities and developing action plans. However, this result supports the idea suggested by Banker et al. (2004), in which they indicated that companies should use both financial and non-financial performance measures to improve decision-making and problem solving.

7.3 Performance measurement gap

To recall from the analysis presented in the aforementioned sub-sections, descending means were used to investigate the importance of financial and non-financial performance categories as drivers of long-term organisational success and their relative use in performance measurements and evaluation in the UK manufacturing companies. Table 7.7 provides summary information relating to the information presented in Tables 7.1-7.6. The findings presented in this table indicate that there is some inconsistency between the scores for the importance of the performance categories to long-term success of a business (column 2) and the scores in the remaining columns 3-7 of the table. For example, the average scores in respect of (1) the use of each performance category in performance measurement and evaluation purposes (columns 4, 5 and 7 in Table 7.7), (2) the extent that strategic goals are established for each category (column 3), and (3) the quality of measures for each category (column 6) are lower than the importance scores for each performance category (column 2). The findings also indicate that there are some differences between using these performance categories for different performance measurement and evaluation purposes (i.e. columns 4, 5 and 7).

The aforementioned differences are known as the measurement gap. According to Ittner and Larcker (2001, p. 382), the measurement gap is defined as the difference between the perceived importance of each performance category and the extent to which (1) the performance category is used for internal purposes, and (2) formal strategic goals are established for the category. However, this study views measurement gap as the differences between the perceived importance of the financial and non-financial performance categories (column 2) and their corresponding uses (columns 4, 5 and 7), setting strategic goals (column 3) and the quality of performance measures (column 6). For example, the largest differences relate to the reward system of customer, innovation, employee, supplier, environment and quality performance categories. Thus, it can be concluded that measurement gaps do exist for all performance categories, indicating that the use of performance measures for one purpose does not imply that the measures are used for other purposes. These differences are

consistent with the measurement gaps identified in several empirical studies (e.g. Lingle and Schiemann, 1996; Stivers et al., 1998). Thus, the differences identified in this study vary across uses, indicating that there are no zero gaps¹ between internal usage, strategic goal setting, measurement quality and the perceived importance score of financial and non-financial performance categories. In addition, these differences indicate that extensive use of financial and non-financial performance measures for one managerial purpose does not necessarily imply these performance measures are used for other purposes.

Table 7.7 Mean survey responses on the importance of performance categories to long-term organisational success and their use in performance measurements and evaluation

(1) Performance categories	(2) Importance to long-term success		(3) Extent goals set		(4) Managerial evaluation		(5) Reward system		(6) Measurement quality		(7) Problem identification	
	Mean	rank	Mean	rank	Mean	rank	Mean	rank	Mean	rank	Mean	rank
Financial	6.49	1	6.26	2	5.98	4	5.64	6	6.01	3	5.97	5
Customer	6.26	1	5.39	2	4.85	5	3.87	6	5.00	4	5.11	3
Operational	5.64	1	5.22	5	5.32	4	4.01	6	5.44	3	5.63	2
Innovation	5.19	1	4.52	2	3.82	4	2.89	6	3.87	3	3.73	5
Employee	4.96	1	4.11	3	3.72	5	2.65	6	4.34	2	4.01	4
Supplier	5.02	1	4.17	4	3.83	5	2.69	6	4.33	2	4.29	3
Environment	4.46	1	3.90	2	3.06	5	2.31	6	3.72	3	3.36	4
Quality	5.86	1	5.43	3	5.00	5	3.56	6	5.48	4	5.52	2
Community	3.75	1	3.01	2	2.34	5	2.01	6	2.56	3	2.44	4

In order to demonstrate the relationship between the importance of each performance category to long-term organisational success (i.e. column 2, Table 7.7), the use of each performance category in performance measurement and evaluation purposes (i.e. columns 4, 5 and 7 in Table 7.7), the extent that strategic goals are established for each category (i.e. column 3) and the quality of measures for each category (i.e. column 6) a correlation matrix² was utilised. The following results show the strength of association for each performance category based on Cohen's (1988) classification (see Chapter 6, sub-section 6.14.4):

¹ A firm is assumed to have zero gap if the scores for internal usage or goal setting is greater than or equal to the perceived importance scores (Ittner and Larcker, 2001).

² For the sake of practicality and ease of presentation, the entire correlation matrix is not presented due to the large number of variables as listed in Table 7.7.

- The importance of financial performance category was highly correlated with setting strategic goals (0.548, $P < 0.01$, 2-tailed), while a moderate correlation was reported with managerial performance evaluation, measurement quality and problem identification (0.389, 0.324, 0.340 respectively, $P < 0.01$, 2-tailed). Small correlation (0.209, $P < 0.01$, 2-tailed) was reported with financial reward system.
- The importance of customer performance category was highly correlated with setting strategic goals (0.602, $P < 0.01$, 2-tailed), while a moderate correlation was reported with measurement quality and problem identification (0.330, 0.339 respectively, $P < 0.01$, 2-tailed). Small correlation was reported with managerial performance evaluation and financial reward system (0.262, 0.134 respectively, $P < 0.01$, 2-tailed).
- The importance of operational performance category was highly correlated with setting strategic goals and measurement quality (0.631, 0.551 respectively $P < 0.01$, 2-tailed), while a moderate correlation was reported with managerial performance evaluation and problem identification (0.432, 0.464 respectively, $P < 0.01$, 2-tailed). Small correlation was reported with financial reward system (0.223, $P < 0.01$, 2-tailed).
- The importance of innovation performance category was highly correlated with setting strategic goals (0.639, $P < 0.01$, 2-tailed), while a moderate correlation was reported with managerial performance evaluation, financial reward system, measurement quality and problem identification (0.496, 0.350, 0.486, 0.436 respectively, $P < 0.01$, 2-tailed).
- The importance of employee performance category was highly correlated with setting strategic goals (0.540, $P < 0.01$, 2-tailed), while a moderate correlation was reported with managerial performance evaluation, measurement quality and problem identification (0.328, 0.315, 0.396 respectively, $P < 0.01$, 2-tailed). Small correlation (0.242, $P < 0.01$, 2-tailed) was reported with financial reward system.
- The importance of supplier performance category was highly correlated with setting strategic goals, managerial performance evaluation, measurement quality and problem identification (0.676, 0.544, 0.598, 0.609 respectively $P < 0.01$, 2-tailed), while a moderate correlation was reported with financial reward system (0.342, $P < 0.01$, 2-tailed).
- The importance of environment performance category was highly correlated with setting strategic goals, managerial performance evaluation, measurement quality and problem identification (0.670, 0.537, 0.527, 0.595 respectively $P < 0.01$, 2-tailed), while a moderate correlation was reported with financial reward system (0.380, $P < 0.01$, 2-tailed).

- The importance of quality performance category was highly correlated with setting strategic goals, managerial performance evaluation, measurement quality and problem identification (0.709, 0.517, 0.547, 0.604 respectively $P < 0.01$, 2-tailed), while a small correlation was reported with financial reward system (0.227, $P < 0.01$, 2-tailed).
- The importance of community performance category was highly correlated with setting strategic goals, managerial performance evaluation, measurement quality and problem identification (0.751, 0.517, 0.597, 0.616 respectively $P < 0.01$, 2-tailed), while a moderate correlation was reported with financial reward system (0.451, $P < 0.01$, 2-tailed).

It is apparent from the above points that the importance of all performance measurement categories to long-term organisational success (column 2 in Table 7.7) are significantly correlated ($P < 0.01$, 2-tailed) with their use in performance measurement and evaluation purposes (columns 4, 5 and 7), setting strategic goals³ (column 3) and the quality of performance measures (column 6). In addition, the correlation matrix provides a clear indication that the use of all performance categories in performance measurement and evaluation purposes (columns 4, 5 and 7), setting strategic goals (column 3) and measurement quality (column 6) are significantly correlated ($P < 0.01$, 2-tailed).

Consequently, the following issues can be concluded from this section:

- Financial and operational performance categories are viewed important to long-term organisational success (column 2, Table 7.7), thus they are widely used by the responding companies in all performance measurement and evaluation purposes (columns 4, 5 and 7 in Table 7.7), strategic goals are set (column 3, Table 7.7) and have greater measurement quality (column 6, Table 7.7).
- Customer, quality, innovation, employee, supplier and environment performance categories are viewed as important for long-term organisational success (column 2), thus they are not widely used in all performance measurement and evaluation purposes (columns 4,5 and 7), setting strategic goals (column 3) and measurement quality (column 6).

³ The importance to long-term organisational success (column 2) and setting strategic goals (column 3) for all performance categories had high correlations since the correlation coefficients for all performance measurement categories exceed 0.5.

7.4 Performance measurements used by business units

Questions A1i-A9i provided information relating to the importance of performance measurement categories (see column 2 of Table 7.7 for a summary of the responses). Columns 3-7 of the table (derived from the responses to questions A1ii-A9ii and A10ii-A27ii) focus on the extent that strategic goals are set, measurement quality and usage of performance measures within each performance category in performance measurement and evaluation purposes. Table 7.8 provides an overall measure relating to the items specified for columns 3-7 of Table 7.7 for each performance category. The measure is calculated through the weighted average of the responses. Thus, the mean score for each performance measurement usage category was calculated by the weighted average of the responses for all uses (i.e. managerial performance evaluation, financial reward system and problem identification), strategic goal setting and measurement quality⁴. Thus, higher mean values for a specific performance category provides an indication that companies use performance measures within the category to a greater extent, set more strategic goals and have greater measurement quality when compared with a performance category with a lower mean score.

Table 7.8 Average usage of performance measurements

Performance measurement usage	Frequency	Average % usage	Mean	Std.Dev
Financial performance	159	97.5	5.97	0.86
Customer performance	134	82.2	4.84	1.05
Operational performance	143	87.7	5.12	1.03
Innovation performance	73	44.8	3.76	1.29
Employee performance	77	47.2	3.76	1.04
Supplier performance	75	46.0	3.86	1.32
Environment performance	57	35.0	3.27	1.28
Quality performance	135	82.8	4.99	1.09
Community performance	24	14.7	2.47	1.16

Table 7.8 indicates that financial performance measurement has an average usage rate of 97.5%. This result is consistent with the findings of other surveys. For example, a survey in the UK found that financial performance measurements are very important in the manufacturing sector, and most companies have a tendency to base their decisions primarily on financial performance (CIMA, 1993). Other evidence from the UK environment (e.g. Drury et al., 1993; Burns and Yazdifar, 2001; Yenyiurt, 2003) suggests that, in practice traditional management accounting practices are perceived to be popular. In the USA, a study

⁴ A single measurement construct was used rather than separate constructs for usage, goal setting and measurement quality because of high correlation among these practices which may create a problem of multicollinearity. However, when separate constructs are computed, the correlation between usage and goal settings is 0.69, between usage and measurement quality is 0.72, and between goal setting and measurement quality is 0.68. This procedure was recently used by Itner, Larcker and Randall (2003) to avoid multicollinearity problem.

conducted by Lingle and Schiemann (1996) found that 98% of the companies use financial performance measurement. In Australia, Chenhall and Langfield-Smith (1998a) found high adoption rates in respect of financial performance measurements.

The above table also shows that the responding companies concentrate mainly on operational, quality and customer performance non-financial measurements in their performance measurement systems with average usage rate of 87.7%, 82.8% and 82.2% respectively. These performance categories were identified in the literature as the most important performance categories that can be used to cope with changing environment (e.g. Eccles, 1991; Drury, 1997). Moreover, several empirical studies (e.g. Drury et al., 1993; Lingle and Schiemann, 1996) found that operational, quality and customer measures are the most widely used non-financial measurements by companies. Finally, several performance measurement frameworks (e.g. the performance pyramid) have also included these performance categories in their measurement systems. The results presented in the above table also show that the responding companies use other non-financial performance measures to a lesser extent in their performance measurement systems. These are innovation, employee, supplier and environment measures with average usage rate of 44.8%, 47.2%, 46% and 35% respectively. The community performance measures rate the lowest percent with average usage rate of 14.7%. The aforementioned results show that the responding companies are using different types of non-financial performance measures. The reasons underlying the use of various non-financial performance measures depend on the usefulness of information provided by these measures on one hand, and the extent to which managers clearly understand the interests of stakeholders and the strategic objectives on the other hand (Stivers et al., 1998).

Based on the above discussion, it can be concluded that the use of non-financial performance measurements are becoming more predominant in performance measurement systems. This result is consistent with the arguments forwarded by several academic researchers (e.g. Bromwich and Bhimani, 1994; Ittner and Larcker, 1998b) to include the non-financial measurements in management accounting systems. Furthermore, several empirical surveys (e.g. Coates et al., 1993; Booth, 1997; Ittner and Larcker, 1998a) found increasing usage rates of several types of non-financial performance measurements. Consistent with claims in the performance measurement literature, greater performance diversity is characterised by more use of financial and non-financial performance measurements. Thus, it can be noted

that all of the responding companies use both financial and non-financial measures in performance measurements and evaluation. This result is consistent with Bititci et al. (2002) who argued that management requires accurate performance information on its customers and markets, financial performance, customer service, operational and suppliers' performance in order to respond to the changing competitive environment. This result also agrees with calls made by several management accounting researchers (e.g. Otley, 2001; Laitinen, 2002; Ittner and Larcker, 2003) and the professional accounting associations (e.g. CIMA) to integrate non-financial with financial performance measurements. Empirically, CIMA (1993, p. 7-8) found that manufacturers increasingly believe that the adoption of a range of performance measures, both financial and non-financial, is a step in the right direction to meet changes in the manufacturing environment and that each manufacturing company should find a balance of measures which it views as sufficient for the management of its operational activities. Thus, it can be concluded that financial performance measures continue to be an important aspect in performance measurement and management accounting. However, these measures are also being supplemented with various non-financial performance measures and the results indicate that there is no specific mix of financial and non-financial performance measures applicable to all manufacturing companies. Thus, firms have great flexibility to choose the portfolio of performance measures that they expect to work best in their situations (Malina and Selto, 2004).

7.4.1 Linking performance measures to strategies

The respondents were asked in question A28 to indicate the extent to which performance measures used in performance measurements and evaluation are linked to their business units' strategies. Table 7.9 shows their responses about the extent to which the performance measures are linked to the strategies adopted by the business units.

Table 7.9 Distribution of the linkages between performance measures and strategies

The extent to which performance categories are linked to strategy	Frequency	Percent	Cumulative percent
Not at all linked (scores of 1-3)	11	6.7	6.7
Linked to a moderate extent (score of 4)	25	15.3	22
Linked to a considerable extent (scores of 5-7)	127	78	100
Total	163	100	

Most of the respondents (78%) agreed to a considerable extent that their performance measures are linked to their business unit strategies. It has been argued in the literature that performance measures should evolve along with companies' strategies and objectives. The

above analysis indicates that the idea of linking performance measures to strategy is high across the respondents and that they consider performance measures adequate in communicating strategy. This is often the result of the linkages between strategy development processes and performance measurement processes (strategy-execution). In this context, Frigo and Krumwiede (2000) indicate that companies should treat strategy development and strategy execution as parallel, interrelated processes, so that once the strategy is well developed the performance measures can be identified. However, companies' actions should be taken to support strategy, and the role of performance measures is to support both actions and strategies (Nanni et al., 1992). Thus, when strategic objectives are achieved using the current performance measures, new objectives should be set requiring new performance measures to control and co-ordinate companies strategies.

The above results also support the assertion made by several management accounting researchers (e.g. Kaplan and Norton, 1996a; Booth, 1997) that a performance measurement system should include both financial and non-financial performance measures that reflect strategy. A comparison with other surveys shows that they have reported similar results in terms of linking performance measures to strategy. For instance, Lingle and Schiemann (1996) reported that performance measurement plays a crucial role in translating business strategy into results and linking strategic measures to operational ones. Guenther and Gruening (2002) also reported that performance measurement systems have to be adjusted to the strategy.

Regarding the aforementioned results, it should be noted that the respondents were not asked to identify how they actually link their performance measures to their strategies. This may be justified based on Braam and Nijssen's (2004b, p. 345) argument in which they argued that the translation of vision and strategy into operational measures is a complicated and dynamic process.

7.4.2 The link between performance measures

The respondents were asked in question A29 to indicate the extent to which non-financial performance measures are causally linked to each other and also to future financial performance outcomes. Table 7.10 shows the responses.

Table 7.10 Distribution of the linkages between non-financial performance measures and future financial performance outcomes

The extent to which non-financial performance categories are causally linked to each other and to future financial performance outcomes	Frequency	Percent	Cumulative percent
Not at all (scores of 1-3)	18	11	11
To a moderate extent (score of 4)	46	28.2	39.2
To a considerable extent (scores of 5-7)	99	60.8	100
Total	163	100	

The most noticeable feature of Table 7.10 is that more than half of the respondents indicated to a considerable extent that their companies link non-financial performance measures to future performance outcomes. Empirically, this result is higher than the results reported in some of the previous studies. For example, Ittner and Larcker (2003) found that 23% of 157 companies built and verified cause-and-effect relationships between the chosen drivers of strategic success and outcomes. Ittner, Larcker and Randall (2003) found that 34.7% of the responding companies link their performance measures in causal business models. This result also supplements one of the main assumptions⁵ of balanced scorecard approach.

It has been argued in the literature that non-financial performance measures are leading indicators of financial performance whereas the empirical studies that investigated the link between non-financial performance measures and future financial performance have shown mixed results (Ittner and Larcker, 1998a). In this context, Ittner and Larcker (2003, p. 90) found that even those companies that create causal models rarely go on to prove that actual improvements in non-financial performance measures affect future financial results. Thus, the determination and checking cause-and-effect relationship between non-financial performance measures and financial performance is a controversial matter. Thus, the aforementioned results may be justified by taking into consideration the following aspects:

- In this study, the respondents were asked to perceive the extent of causal linkages between non-financial performance measures and future performance outcomes rather than verifying whether these linkages has any basis in fact.
- Based on the idea that establishing logical causal relationships between the performance measures is problematic (Laitinen, 2002), this study did not ask the respondents if they had actually established any connections between non-financial and financial performance.

⁵ See discussion in Chapter 3 (section 3.4 and sub-section 3.6.3) relating to cause-and-effect assumption. Also, a useful discussion of this assumption may be found in Ittner and Larcker (2003, p. 90-92).

- This research uses a cross-sectional study which collects information at a point in time, and time is not a variable in such studies, thus it may not be possible to investigate the cause-and-effect relationships of the balanced scorecard approach.

7.5 State of balanced scorecard implementation

To identify the balanced scorecard (BSC) implementation stage, the respondents were asked in question B1 to indicate which of various stages best described their business unit's current situation. Table 7.11 shows their responses about the extent to which BSC is used in their performance measurement systems.

Table 7.11 State of balanced scorecard implementation stages

State of balanced scorecard implementation	Number of companies	Percent
1. Not considered	69	42.3
2. Implemented & abandoned	4	2.5
3. Considering	38	23.3
4. Approved for implementation	3	1.8
5. Implementing now	12	7.4
6. Used	31	19.0
7. Used extensively	6	3.7
Total	163	100

It can be noted from the above table that approximately 42% of the responding companies had not considered the BSC concept in their performance measurement systems. Similar findings have also been reported in respect of studies undertaken in the USA (Frigo and Krumwiede, 1999), Germany, Austria and Switzerland (Speckbacher et al., 2003). Respectively, they reported that 47% and 43.5% of the surveyed companies have not considered or had been in contact with the BSC concept. The above table also shows that 2.5% of the responding companies reported that they had implemented and abandoned⁶ the BSC concept from their performance measurement system. A comparison with other surveys indicates that they have reported very similar results. For instance, Frigo and Krumwiede (1999) and Ittner, Larcker and Randall (2003) reported 2% and 1.4% respectively.

The analysis of BSC implementation stages as shown in the above table reported that 23.3% of the responding companies had considered implementing this concept. This is slightly higher than the results reported in some of the previous studies. For example, previous studies (Frigo and Krumwiede, 1999; Gehrke and Horvath, 2002; Ittner, Larcker and Randall,

⁶ An effort was made to contact the respondents of these companies to identify the reasons for implementing and abandoning the BSC, but the respondents refused to disclose any information related to the reasons for abandoning the BSC in their companies.

2003) have reported a consideration rate ranging from 14% to 20%. In addition, the above analysis reported that approximately 1.8% of the companies had approved this concept to be implemented. This is lower than the results reported in some of the previous studies. For example, Speckbacher et al. (2003) have reported a 6% approval rate. However, this result conforms to the comments made by several researchers (e.g. Atkinson et al., 1997; Chenhall and Langfield-Smith, 1998a; Malmi, 2001), in which they indicated that the balanced scorecard has attracted considerable interest among companies.

The balanced scorecard (BSC) implementation rate is 30.1% (N = 49). It consists of the sum of rows 5, 6 and 7 of Table 7.11. A comparison with other studies conducted in the UK and USA indicates that they have reported higher results in terms of BSC implementation. Studies in the UK (Anonymous, 2001) and USA (Silk, 1998) have reported implementation rate of 57% and 60% respectively. Another study in the UK (Francis and Minchington, 2000) has reported increasing popularity of the BSC at the divisional level with 24% usage rate in different sectors and 21% usage rate in the manufacturing sector. However, a comparison with European surveys that have focused on BSC indicates similar results. Surveys in Finland (Pere, 1999), Sweden (Kald and Nilsson, 2000), Denmark (Nielsen and Sorensen, 2003) and Germany, Austria and Switzerland (Speckbacher et al., 2003) have all reported that the implementation rate of BSC is 30%, 27%, 32% and 26% respectively.

It can be concluded from the above discussion that despite the popularity of the BSC, only a minority of companies reported using it in their performance measurement systems. In their writings, Kaplan and Norton (2001c) indicated that there are several types of scorecards frequently used by companies. In practice, several empirical studies (e.g. Malmi, 2001; Nielsen and Sorensen, 2003; Speckbacher et al., 2003) have reported that companies are implementing the BSC in different ways. However, to provide further insights into how companies are using the BSC, questions B2-B5 required the respondents (N = 49) to indicate the characteristics and the contents of their BSCs. These are presented in the following sub-sections.

7.5.1 Type of balanced scorecard perspectives

The respondents were asked in question B2 to indicate which perspectives are used in their balanced scorecards. Table 7.12 shows the type of perspectives used by BSC companies.

Table 7.12 Type of perspectives used in the balanced scorecard

Type of perspectives	Frequency	Percent
Financial	49	100
Customer	47	95.9
Internal business process (i.e. operational)	43	87.8
Learning and growth (i.e. innovation)	19	38.8
Supplier	22	44.9
Employee	32	65.3
Environment	13	26.5
Other perspectives	3	6.1
Total	49	100

It can be noted from the above table that most of the BSC companies use the first three perspectives (i.e. financial, customer, internal business process) of the original BSC. Interestingly, only 38.8% of the BSC companies use the learning and growth perspective. However, this result is in line with Speckbacher et al. (2003) findings, in which they reported that almost all of the BSC companies use the first three perspectives of the original BSC and almost half of them use the learning and growth perspective. The table also shows that the BSC companies use additional perspectives. These are employee, supplier and environment (65.3%, 44.9% and 26.5% respectively). This result is in line with Edvinsson and Malone (1997) and Schiemann and Lingle (1999) propositions, but not with those of Kaplan and Norton (1997), who indicated that employee perspective is incorporated within the learning and growth perspective and supplier perspective is incorporated within the internal business process perspective. Noticeably, the above table shows that three BSC companies (6.1%) indicate that they are using a quality perspective in their BSC. Several researchers (e.g. Olve et al., 1999; DeBusk et al., 2003) have indicated that the name and number of perspectives are situational and several performance perspectives may be incorporated within other perspectives. Thus, it should be noted that companies may also use perspectives using different definitions such as including employee as a separate item, rather than naming it as a perspective within the learning and growth perspective (i.e. companies may be using the learning and growth perspective but under a different name). Similarly, quality and supplier may be captured as items within the internal business process perspective.

Consequently, the aforementioned results show that the BSC companies report using several types of perspectives in their BSCs. This suggests that companies who claim to be using the BSC are identifying different perspectives that cope with their objectives. Therefore, it can be concluded that the type and number of perspectives used in the BSCs is different.

However, to provide further insights into how companies are using the perspectives, Table 7.13 shows the number of perspectives used by the BSC companies.

Table 7.13 Number of perspectives used in the balanced scorecard

Number of perspectives	Frequency	Percent
Two perspectives	1	2
Three perspectives	6	12.2
Four perspectives	14	28.6
Five perspectives	19	38.8
Six perspectives	6	12.2
Seven perspectives	3	6.1
Total	49	100

An essential feature of BSC is the number of perspectives used. It can be noted from the above table that only one company uses two perspectives in their BSC, and six companies use only three perspectives. This result is similar to the findings by Malmi (2001) but not with those of Kaplan and Norton (1996c, p. 34) who indicate that they had not identified companies using fewer than the four perspectives. Interestingly, the results show that fourteen companies use only four perspectives in their BSC and six of them have used only the original four perspectives suggested by Kaplan and Norton. The results also indicate that almost half of the BSC companies (N = 28) use more than four perspectives (38.8% five perspectives, 12.2% six perspectives and 6.1% seven perspectives). To perceive the type of perspectives, Table 7.14 shows the components of the perspectives used in each of the BSC companies.

Table 7.14 Components of the perspectives used by the balanced scorecard companies

Types of perspectives used by companies	Frequency	Percent
Financial, environment	1	2
Financial, customer, employee	1	2
Financial, customer, environment	1	2
Financial, customer, supplier	2	4.1
Financial, customer, internal business process	2	4.1
Financial, internal business process, employee, quality	1	2
Financial, customer, learning and growth, supplier	1	2
Financial, customer, internal business process, supplier	1	2
Financial, customer, internal business process, learning and growth	6	12.2
Financial, customer, internal business process, employee	5	10.2
Financial, customer, internal business process, learning and growth, environment	1	2
Financial, customer, internal business process, supplier, environment	1	2
Financial, customer, internal business process, employee, environment	4	8.2
Financial, customer, internal business process, learning and growth, employee	5	10.2
Financial, customer, internal business process, supplier, employee	8	16.3
Financial, customer, internal business process, learning and growth, supplier, environment	1	2
Financial, customer, internal business process, learning and growth, supplier, employee	2	4.1
Financial, customer, internal business process, supplier, employee, environment	3	6.1
Financial, customer, internal business process, learning and growth, supplier, employee, quality	2	4.1
Financial, customer, internal business process, learning and growth, supplier, employee, environment	1	2
Total	49	100

In summary, it can be noted from the above discussion that different views were identified concerning the types and the number of perspectives used in the BSC. Interestingly, 12% of the BSC companies use only the original four perspectives suggested by Kaplan and Norton (1992), while, the majority of those companies use different combinations of financial and non-financial perspectives. Thus, it can be concluded that the content and implementation of the BSC are different between companies. This conclusion is consistent with the BSC literature (e.g. Roest, 1997; Olve et al., 1999; Braam and Nijssen, 2004b; Ax and Bjornenak, 2005).

7.5.2 Number of strategic objectives and measures used in the balanced scorecard

The respondents were asked in question B3 to indicate the number of strategic objectives and the number of performance measures that are incorporated in their scorecard for each perspective used. A total of 43 of 49 BSC companies (87.7%) answered this question indicating the number of strategic objectives and measures used in their scorecards. The six non-responding companies (12.3%) indicated that they are using both strategic objectives and measures in their BSCs, but they were unable to determine the specific number of these objectives and measures. The responses are summarised in Tables 7.15 and 7.16. The first table represents the number of objectives identified for each perspective, while the second table represents the number of performance measures, which are articulated from the objectives of each perspective.

Table 7.15 Analysis of strategic objectives used for each perspective

Perspectives	1 objective		2 – 3		4 – 5		6 – 10		More than 10		Missing		Total	
	N	%	N	%	N	%	N	%	N	%	N	%	N	%
Financial (N = 49)	7	14.3	25	51	9	18.4	1	2	1	2	6	12.2	49	100
Customer (N = 47)	8	17	24	51	7	14.9	1	2.1	-	-	7	14.3	47	100
Internal business process (N = 43)	7	16.2	16	37.2	10	23.2	3	6.9	-	-	7	16.3	43	100
Learning and growth (N = 19)	5	26.3	11	57.8	2	10.5	1	5.2	-	-	-	-	19	100
Supplier (N = 22)	5	22.7	11	50	3	13.6	-	-	-	-	3	13.6	22	100
Employee (N = 32)	12	37.5	10	31.2	2	6.3	-	-	-	-	8	25	32	100
Environment (N = 13)	7	53.8	4	30.7	-	-	-	-	-	-	2	15.3	13	100
Other (N = 3)	2	66.7	1	33.3	-	-	-	-	-	-	-	-	3	100

Table 7.16 Analysis of performance measures used for each perspective

Perspectives	1 measure		2 – 3		4 – 5		6 – 10		More than 10		Missing		Total	
	N	%	N	%	N	%	N	%	N	%	N	%	N	%
Financial (N = 49)	2	4.1	6	12.2	17	34.7	12	24.5	6	12.2	6	12.2	49	100
Customer (N = 47)	3	6.4	22	46.8	8	17	6	12.7	2	4.3	6	12.7	47	100
Internal business process (N = 43)	2	4.6	12	27.9	11	25.6	9	20.9	3	6.9	6	13.9	43	100
Learning and growth (N = 19)	5	26.3	5	26.3	4	21	4	21	-	-	1	5.3	19	100
Supplier (N = 22)	6	27.3	6	27.3	6	27.3	1	4.5	-	-	3	13.6	22	100
Employee (N = 32)	7	21.8	11	34.4	4	12.5	5	15.6	-	-	5	15.6	32	100
Environment (N = 13)	1	7.7	6	46.1	2	15.4	2	15.4	-	-	2	15.4	13	100
Other (N = 3)	1	33.3	1	33.3	1	33.3	-	-	-	-	-	-	3	100

The above tables show that the BSC companies use a wide range of strategic objectives and performance measures (ranging from one to ten for each perspective). This indicates that these companies are combining their strategic objectives and performance measures in their BSCs. This result is similar to the idea suggested by Kaplan and Norton (1992), in which they indicated that BSC companies should articulate the major goals for each of the perspectives, and then translate these goals into specific performance measures. In the same vein, Chow et al. (1997) argued that companies who apply the BSC should recognise the relevant measures for their use dependent on the objectives and strategies they seek to attain. Table 7.17 provides further insights about the total number of strategic objectives and measures used in BSC's.

Table 7.17 Total number of strategic objectives and measures used in the balanced scorecards

1. A total number of strategic objectives	Number of companies	Percent
1 – 5 objectives	4	8.2
6 – 10 objectives	18	36.7
11 – 15 objectives	12	24.5
16 – 20 objectives	6	12.2
More than 20 objectives	3	6.1
Missing	6	12.2
Total	49	100

2. Total number of performance measures	Number of companies	Percent
1 – 10 measures	7	14.3
11 – 20 measures	20	40.8
21 – 30 measures	8	16.3
31 – 40 measures	3	6.1
More than 40 measures	5	10.2
Missing	6	12.2
Total	49	100

The results show that 14.3% of the BSC companies use between 1 to 10 total performance measures, 40.8% use between 11 to 20 measures and 32.6% use more than 20 measures.

Kaplan and Norton (1992) recommend between 16 and 20 measures for the original four perspectives. Salterio and Webb (2003) advocate that the BSC should contain between 16 and 28 measures organised into the original four perspectives. Leauby and Wentzel (2002) found that some companies have used 70 to 80 measures in their scorecard. However, it can be concluded that BSC companies can develop and use performance measures in each of the perspectives that cope with their company's objectives that stem from business strategy. Thus, the wide range of strategic objectives and performance measures is due to the inconsistency between companies' objectives that stem from the different strategies. Consequently, the results presented in Table 7.17 are similar to the aforementioned ideas taking into consideration the number of perspectives⁷ used by BSC companies.

7.5.3 Balanced scorecard components

To recall from Chapter 3, it can be noted that the BSC is a dynamic concept. It was initially introduced as a performance measurement system containing both financial and non-financial performance measures based upon a company's strategy (Kaplan and Norton, 1993). Recent writings on the BSC indicate its development to a strategic management system by linking performance measures into cause-and-effect relationships (Kaplan and Norton, 1996c). More recent writings (e.g. Otley, 1999; Malmi, 2001) stress that the implementation of BSC should include defining objectives, action plans and linking reward system to the BSC performance measures. Based on these developments, Speckbacher et al. (2003) suggest several criteria to identify the components of BSC. First, the BSC should contain strategic measures or strategic objectives. Second, cause-and-effect relationships should be formulated between the performance measures. Third, action plans or targets for strategy implementation should be set and finally BSC measures should be linked to the reward system. To analyse the extent to which the above criteria are considered Table 7.18 presents information relating to the BSC users in respect of their responses to several parts of sections A and B of the questionnaire.

Table 7.18 Components of the balanced scorecards

Components	Number of companies (N = 49)	Percent
Strategic measures or strategic objectives	49	100
Cause-and-effect relationships	46	93.8
Action plans or targets	30	61.2
Linked to reward system	17	34.6

⁷ The results show that 28.6% of the responding companies use only four perspectives and 57.1% use more than four perspectives

It can be noted from the above table that all the analysed BSCs contain strategic performance measures that are linked to the companies' objectives and strategies. This result could be interpreted as BSC companies are able to determine their strategies clearly enough to derive an appropriate set of performance measures. This result is similar to Speckbacher et al. (2003) findings, in which they reported that all of the responding companies are using strategic objectives or/and strategic measures in their scorecards.

The results also show that 30 of 49 companies (61.2%) already use action plans or targets for strategy implementation. Moreover, 17 of the 49 companies (34.6%) have linked reward system to their BSCs. These two results agree with the findings presented by several researchers (e.g. Otley, 1999; Wongrassamee et al., 2003) linking the BSC to targets and the reward system. For example, Speckbacher et al. (2003) found that 73% of the companies use action plans or targets in their BSCs and 47% have directly linked their BSCs to their reward system. Interestingly, the results of this study (see Table 7.18) show that the majority of the BSC companies (93.8%) indicated that they were able to formulate cause-and-effect relationships among their objectives and measures. However, this is one of the main assumptions of the BSC according to Kaplan and Norton (1996c) and recent BSC management accounting research (e.g. Norreklit, 2000; Malmi, 2001). With respect to the 46 companies which claimed to employ cause-and-effect relationships, this study did not actively ask the respondents how they established these relationships.

7.5.4 Results of balanced scorecard implementation

The respondents were asked in question B4 to indicate the results that have been achieved through the use of the BSC. The question listed six results, in addition, an 'other' category was used to allow the respondents to identify other results that were not listed in the question. The findings are presented in Table 7.19.

Table 7.19 Results of balanced scorecard implementation

Balanced scorecard results	Number of companies (N =49)	Percent
We have achieved quantifiable breakthrough financial results	8	16.3
We have achieved operational results (e.g. process improvements, increased efficiency)	27	55.1
We have achieved other organisational benefits (e.g. communication, organisational alignment)	27	55.1
Too early to tell about the results	9	18.4
No results	2	4.1
The program failed	0	0
Other	0	0

It can be noted from the above table that different results have been achieved by companies through the use of the BSC, but operational results and other organisational benefits represent the most widely results achieved with 55.1% for each one. These two results are in line with a variety of purposes and results suggested in the BSC literature (e.g. Kaplan and Norton, 1996c; Norreklit, 2000; Malmi, 2001). Empirically, Lawson et al. (2003b) reported that 72.7% of the respondents agreed that the BSC was used to achieve organisational goals. Moreover, Speckbacher et al. (2003) found that 57% of the respondents agreed on the fact that the BSC improves company results in the long-term.

The above table also shows that quantifiable breakthrough financial results represent the least result achieved through the implementation of BSC (16.3%). This result is similar to the findings presented by several researchers (e.g. Sandt et al., 2001), in which they indicate that there is limited evidence to support the claim that using the BSC leads to improve financial results. Table 7.19 also shows that 18.4% (N = 9) of the responding companies have indicated that it is too early to identify the results of implementing the BSC. It should be noted that six of these companies had only recently started BSC implementation. Finally, 4.1% indicated that no results were achieved from using the BSC.

7.5.5 Level of balanced scorecard implementation

Question B5 asked the respondents to indicate the appropriate organisational levels where the BSC are applied. Table 7.20 shows the percentages of BSC usage in different organisational levels.

Table 7.20 Level of balanced scorecard implementation

Organisational levels	Number of companies (N = 49)	Percent
Corporate level	22	44.9
Business unit level	41	83.7
Plant level	20	40.8
Department level	17	34.7
Team level	7	14.3
Employee level	5	10.2

It can be noted from the above table that the majority of the BSC companies (83.7%) apply this approach at the business unit. This is consistent with Kaplan and Norton's (1996c) idea, in which they argued that the BSC should be primarily applied at the business unit level, where the competitive strategies become essential. Empirically, this result agrees to some extent with the findings of Speckbacher et al. (2003), in which they reported that almost 98%

of the companies apply this approach at the business unit level. Table 7.20 shows that approximately 45% of the BSC companies reported that they had implemented this approach at the corporate level. This result is in line with the recommendation of Lawson et al. (2003a) that companies could implement the BSC for corporate level first and then roll out this approach to other organisational levels. Similar results, however, have been reported in relation to survey studies. For example, Speckbacher et al., (2003) found that 55% of the companies apply the BSC at the corporate level.

The results also show an interesting rate of implementation at several lower organisational levels (40.8% at plant level, 34.7% at department level, 14.3% at team level and 10.2% at employee level). In this vein, Kaplan and Norton (1996c) argue that some companies have applied the BSC on one organisational level, while other companies have been applied this approach on various levels. These results may be interpreted and justified as the BSC can be used to communicate strategy at all parts and members of the organisation (Kaplan and Norton, 1996c; Norreklit, 2000). Empirically, Malmi (2001, p. 211) found that there were BSCs at departmental and activity levels and the intention of these companies is to develop scorecards at lower organisational levels.

7.6 Mean differences between balanced scorecard users and non-users

As reported earlier in this chapter, 49 companies claimed to use the BSC in their performance measurement systems whereas 114 companies do not use it. Therefore, it was decided to examine whether the responses to questions A1 – A27 relating to the importance of performance measurements, extent that strategic goals are set, measurement quality and their corresponding use in performance measurement and evaluation purposes are related to the use of BSC. In other words, it is appropriate to report the mean differences between BSC users and non-users in terms of performance measurement characteristics and practices. Thus, Table 7.21 summarises these differences. The table lists the significant mean rank differences between BSC users and non-users based on Mann-Whitney test. Although no hypotheses have been formulated, the literature review supports the hypothesis that balanced scorecard users would be expected to have higher scores for all performance categories in relation to the responses to questions A1-A27. Given that directional hypotheses have some theoretical justification, Table 7.21 has been derived from using one-tailed significance tests.

Table 7.21 Significant mean differences in performance categories and measurement characteristics between balanced scorecard users and non-users

Performance measurement characteristics	Performance categories	Mean differences	<i>P</i> -value (1-tailed)
Drivers of long-term organisational success	Employee	19.77	0.011
	Supplier	16.1	0.039
Extent goals set	Customer	26.11	0.001
	Innovation	21.13	0.008
	Employee	34.20	0.000
	Supplier	23.49	0.003
	Environment	19.37	0.015
	Community	18.90	0.017
Extent used in managerial performance evaluation	No differences	-	-
Extent used in financial reward	Customer	19.83	0.013
	Employee	23.35	0.003
	Supplier	26.19	0.001
	Quality	16.3	0.040
Measurement quality	Employee	16.64	0.034
	Environment	16.28	0.040
	Community	18.52	0.018
Extent used in problem identification and developing action plans	Customer	17.22	0.028
	Innovation	22.51	0.004
	Employee	27.9	0.000
	Supplier	16.77	0.035

It can be noted from the above table that several differences exist between BSC users and non-users. The mean ranks regarding performance categories as drivers of long-term organisational success are significantly different ($P < 0.05$, 1-tailed) for employee and supplier categories. To recall from our discussion in sub-section 7.5.1, the usage rate of employee and supplier perspectives in the BSC companies' are 65.3% and 44.9% respectively. Thus, this result indicates that companies claiming to use the BSC place greater emphasis on employee and supplier categories as drivers of long-term organisational success than non-users.

The mean ranks regarding goals setting are significantly different ($P < 0.01$, 1-tailed) between BSC users and non-users for customer, innovation, employee, and supplier performance. The mean ranks are also significantly different ($P < 0.05$, 1-tailed) for environment, and community performance. Apart from community⁸, this result indicates that BSC users set strategic goals more extensively for these performance categories than non-users. Noticeably, the mean ranks regarding the performance categories used in managerial performance evaluation did not report any significant differences between BSC users and non-users.

⁸ Companies who claimed to use the BSC did not report using community perspective in their balanced scorecards.

The mean ranks regarding the performance categories used in financial rewarding system are significantly different ($P < 0.05$, 1-tailed) for customer and quality performance. The mean ranks are also significantly different ($P < 0.01$, 1-tailed) for employee and supplier performance. This result indicates that companies claiming to use the BSC place greater emphasis on these four non-financial categories than non-users in rewarding managers. Moreover, the mean ranks regarding measurement quality are significantly different ($P < 0.05$, 1-tailed) for employee, environment and community performance. Apart from community performance, this result indicates that BSC adopters use the information within the employee and environment performance categories more than non-users. Finally, the mean ranks regarding problem identification and developing action plans are significantly different ($P < 0.01$, 1-tailed) for innovation and employee performance. The mean ranks are also significantly different ($P < 0.05$, 1-tailed) for customer and supplier performance. This result indicates that BSC users are depending more extensively on these performance categories for identifying problems and improvement opportunities and developing action plans than non-users.

It can be concluded from the aforementioned discussion that several differences were identified relating to the use or non-use of the BSC. Overall, the evidence in Table 7.21 indicates that differences in non-financial performance categories and performance measurement characteristics tend to be greater between BSC users and non-users. The evidence also indicates that many common perceptions about the non-financial performance measures and measurement characteristics of BSC users are to some extent correct, with BSC users exhibiting several significant differences from non-users. Therefore, the differences in the two groups (i.e. BSC users and non-users) support the idea that companies claiming to use BSCs are using the information in performance measurements and evaluation more than non-users. To provide further insights into these claims, Table 7.22 shows the mean rank differences between BSC users and non-users in terms of linking performance measures to business strategies on one hand, and the degree to which these performance measures are causally linked in cause-and-effect relationships on the other hand. The table lists the significant mean rank differences between BSC users and non-users based on Mann-Whitney test. Although no hypotheses have been formulated the literature review supports the hypothesis that BSC users would be expected to have higher scores in relation to the responses to questions A28-A29. Given that directional hypotheses have some theoretical justification, Table 7.22 has been derived from using one-tailed significance tests.

Table 7.22 Significant mean differences in performance measurement characteristics between balanced scorecard users and non-users

Performance measurement characteristics	Mean differences	P-value (1-tailed)
The link between performance measurement and strategy	32.50	0.000
Cause-and-effect relationships	24.47	0.002

It can be noted from the above table that differences exist between BSC users and non-users. The mean ranks regarding the link between performance measures and business strategy and the cause-and-effect relationships are significantly different ($P < 0.01$, 1-tailed). These results indicate that the idea of linking performance measures to business strategy, and the cause-and-effect relationships is higher for the companies claiming to use the BSC compared with the non-users. However, these two performance measurement characteristics are known as integral components of the BSC. Therefore, these differences between the two groups (i.e. BSC users and non-users) support the idea that companies claiming to use BSCs are using two important assumptions of this approach in their performance measurement systems more than non-users.

7.7 Respondents' satisfaction with performance measurement systems

The respondents were asked in section H (questions H1 – H3) to indicate the level of satisfaction with their performance measurement systems. The three satisfaction questions load on to a single construct (see Chapter 8, sub-section 8.2.10). Therefore, the satisfaction construct represents the average standardised response to the three questions. A summary of the average responses to questions H1-H3 is presented in Table 7.23. This table indicates that 44.9% of the respondents whose companies had used BSC assigned on average scores of 5, 6 or 7 compared with 24.5% for those not using BSC. The differences were significant ($P < 0.01$, 2-tailed) using the Mann Whitney test.

Table 7.23 Respondents' satisfaction with performance measurement systems

Responses	N	Mean	Standard deviation	% rating 1, 2 or 3	% rating 4	% rating 5, 6 or 7
All companies	163	4.23	1.064	36.2	33.1	30.7
Companies that have used BSC	49	4.56	1.000	24.5	30.6	44.9
Companies that have not used BSC	114	4.09	1.063	41.2	34.2	24.5

It can be noted from the above table that all the responding companies, on average, are moderately satisfied with their performance measurement systems. This result is similar to Ittner, Larcker and Randall (2003) findings, in which they reported that companies making extensive use of broad set of financial and non-financial measures have a moderately greater

satisfaction. The results also show that companies claiming to use the BSC have achieved a moderately greater satisfaction compared with non-users. This is consistent with other performance measurement empirical studies (e.g. Rigby, 2001). According to Ittner and Larcker (1998a), Towers and Perrin (i.e. a consulting firm) found from their empirical study that 64% of the responding companies reported that the satisfaction from using the BSC approach was higher than the satisfaction gained from using other performance measurement systems. No effort has been made in this chapter to investigate the influence of possible contingent variables on the BSC usage since this is the main objective of Chapter 9. However, it is crucial at this stage to provide an impression of the industry type for companies who claim that they are using the BSC. Table 7.24 shows the results based on the classifications employed in Chapter 6, sub-section 6.11.1.

Table 7.24 Characteristics of balanced scorecard users in terms of industry type

Industry type	Frequency of BSC users (N = 49)	Total responses (N = 163)	Percent
Plastic products	1	5	20.0
Aerospace & defence equipment	5	8	62.5
Food, drinks & tobacco products	9	34	26.4
Industrial & commercial machinery	3	10	30.0
Chemicals & pharmaceutical products	5	14	35.7
Motor vehicles, shipbuilding & motorcycles	3	8	37.5
Electronics & electrical including IT products	5	18	27.7
Paper & stationery, cartoons, boxes, packaging	4	11	36.3
Steel & fabricated metal including medical devices	1	12	8.3
Domestic products including furniture & electrical pulps	4	12	33.3
Engineering products including automotive parts, engines	4	13	30.7
Other products including printing, beauty, media.....	2	7	28.5
Textile, cotton, wool, clothing	0	6	0.0
Not responded	3	5	60.0

Apart from textile, cotton, wool, and clothing industry, it can be noted from the above table that the usage of the BSC is highly across all types of manufacturing industry. Chi-square test was used to determine if there was a significant difference between the companies that have used the BSC and the companies that have not. The results indicated that there were no significant differences ($P > 0.05$, 2-tailed) in BSC usage across manufacturing industry.

7.8 Summary

This chapter has presented the findings and discussion relating to the first and fourth objectives of the research. In particular, it has presented descriptive findings relating to performance measurement systems (section A of the questionnaire) and the nature, content and usage of the balanced scorecard (section B of the questionnaire). The responses to the

remaining questions are mainly concerned with providing information relating to the contingent variables influencing the nature and content of the performance measurement systems. Therefore, this chapter has not attempted to provide descriptive information relating to these variables. Approximately, all of the responding companies operate performance measurement systems comprising of *financial and non-financial performance measures*. However, the findings indicate that there were differences between the importance of performance measurement categories and their relative use in performance measurements and evaluation thus, indicating a measurement gap. It was observed that financial performance measurements are the dominant measures for the responding companies. In addition, non-financial performance measurements (i.e. operational, customer and quality) had high usage rates whereas employee, supplier, innovation and environment had only moderate usage rates. Noticeably, 78% of the responding companies' link to a considerable extent performance measures to their strategy, and approximately 60% identify cause-and-effect relationships between non-financial measures and future financial outcomes.

Of the 163 respondents, 30.1% had implemented balanced scorecard (BSC) in their performance measurement systems. A greater proportion of the BSC users reported using financial, customer and internal business process perspectives in their BSCs. Also, 12% of the BSC users reported using only the original four perspectives suggested by Kaplan and Norton. In addition, the results show that BSC users employ a wide range of strategic objectives and strategic measures for each perspective. Operational results and organisational benefits are the most important results that have been achieved through the use of the BSC. The BSC usage was applicable at different organisational levels. The dominant level was the business unit level. A significant greater proportion of the BSC users reported that they were satisfied with their performance measurement systems compared with non-BSC users. There was evidence to support the existence of differences between BSC users and non-users thus, supporting the idea that BSC users were using the information in performance measurements and evaluation more than non-users.

The main aim of this chapter has been to present the descriptive findings and the implications of two objectives of this research. In the next chapters, the aim is to explain the measurement model of the research variables applicable to testing the research hypotheses.

Chapter 8

Measurement model analysis

8.1	Introduction.....	8-2
8.2	Measurement analysis of research variables.....	8-2
	8.2.1 Business strategy.....	8-3
	8.2.2 Organisational structure.....	8-5
	8.2.3 Perceived environmental uncertainty.....	8-6
	8.2.4 Intensity of competition.....	8-8
	8.2.5 Organisation size.....	8-9
	8.2.6 Total quality management.....	8-10
	8.2.7 Just in time manufacturing approaches.....	8-11
	8.2.8 The extent of performance measurement diversity usage (PMD).....	8-12
	8.2.9 The extent of balanced scorecard usage (BSCUSE).....	8-14
	8.2.10 Organisational effectiveness.....	8-17
8.3	Descriptive statistics for research variables.....	8-19
8.4	Statistical methods used for testing research hypotheses.....	8-21
	8.4.1 Structural equation modelling assumptions.....	8-21
	8.4.2 Structural equation modelling computer programs.....	8-22
	8.4.3 Dealing with outliers and missing data.....	8-22
	8.4.4 The structural model goodness-of-fit evaluation.....	8-23
	8.4.5 Statistical significance of parameters estimates.....	8-24
	8.4.6 Sample size and model complexity.....	8-25
	8.4.7 The variables used in testing research hypotheses.....	8-27
8.5	Summary.....	8-28

Chapter 8

Measurement model analysis

8.1 Introduction

It was pointed out in Chapter 5 that the theoretical constructs ‘variables’ identified were operationalised based on previous studies. The measurement of these constructs is crucial to ensure the reliability and validity of the expected results in order to achieve the research objectives. It was emphasised in sub-section 5.4.3 that the balanced scorecard (BSC) is applied in different ways, and that different interpretations exist as to what represents the adoption of a BSC performance measurement system. However, the descriptive findings of this study confirmed that companies are using the BSC in different ways (see Chapter 7, section 7.5). Thus, this study contributes to BSC literature by developing several steps to ensure that the responding companies are really BSC users.

The aim of this chapter is to explain how the research variables are measured, and the procedures undertaken to establish the construct validity using both exploratory and confirmatory factor analysis. In addition, the chapter summarises the descriptive statistics of the research variables and the statistical methods used to test the research hypotheses. The next section (section 8.2) presents the measurement analysis of the research variables and the outputs of both the exploratory and confirmatory factor analysis. Section 8.3 describes the descriptive statistics for the variables required for testing the hypotheses developed in Chapter 5. Section 8.4 discusses the statistical methods used for testing research hypotheses. Finally, the chapter summary is presented in section 8.5.

8.2 Measurement analysis of research variables

In Chapter 6 it was indicated that multiple-item questions (based on 7-point scales) were extensively used in this research to measure the contingent variables, which may influence the extent of performance measurement diversity usage (PMD) and the extent of balanced scorecard usage (BSCUSE). These types of questions require a statistical method that can be used to aggregate the multiple-item question responses in order to determine the overall measure for the variable. In this context, Hair et al. (1998) indicate that both exploratory factor analysis (EFA) and confirmatory factor analysis (CFA) are the appropriate methods for assessing construct validity (see sub-section 6.13.1 in Chapter 6 for an explanation of

construct validity). Thus, exploratory factor analysis (EFA)¹ was performed (see sub-section 6.14.2 in Chapter 6 for an explanation of EFA) to operationalise these variables and to test the degree to which the items are tapping the same concept. Moreover, it has been recommended that confirmatory factor analysis (CFA), derived from structural equation modelling (SEM), is a more rigorous test of unidimensionality (Garver and Mentzer, 1999, p. 40). Thus, confirmatory factor analysis (CFA)² was also utilised to confirm or refine the unidimensionality of measurements that resulted from the exploratory factor analysis (see sub-section 6.14.3 in Chapter 6 for an explanation of CFA). Finally, to test the internal consistency, Cronbach's alpha was used to measure the reliability of the variables resulting from the factor analysis. A detailed discussion of the results of the factor analysis and the reliability of the variables used in this research is presented in the next sub-sections.

8.2.1 Business strategy

It was pointed out in Chapter 5 (sub-section 5.4.1.1) that business strategy has been operationalised by using two approaches. The first approach measures Miles and Snow's (1978) strategic types of prospector, defender, analyser and reactor (Olson and Slater, 2002). The second approach measures Porter's types of differentiation and low cost strategies. In Chapter 5 it was indicated that the decision was made to adopt the second approach (i.e. Porter's strategies). This approach was developed by Govindarajan (1988) to measure low cost and differentiation strategies as a continuum. Based on the two dimensions of business strategy, it was decided to separate the items (C4-C10) into two strategies. The first two items (C4 and C5) attempted to measure low cost strategy and the last five items (C6-C10) measure differentiation strategy. Based on Lee and Miller's (1996) method of measuring low cost strategy, reverse scoring for items (C4 and C5) were used to identify this strategy. The results of EFA identified three factors for business strategy that explained 69 percent of variability of business strategy with eigen values greater than one. These factors were

¹ To assess the exploratory factor analysis (EFA), five commonly used assumptions were followed (Hair et al., 1998; Field, 2000): Sampling adequacy (Kaiser-Meyer-Olkin measure greater than 0.5); the minimum eigen value for each factor to be one; considering the sample size, factor loading of .40 for each item was considered as the threshold for retaining items to ensure greater confidence; the determinant of the correlation matrix (more than 0.00001); varimax rotation was used since it is a good general approach that simplifies the interpretations of factors (Field, 2000, p. 449). Once the number of factors have been determined, the next step is to try to interpret them. Statistical Package for Social Sciences (SPSS) shows you, which variables 'clump together'. From your understanding of the contents of variables (and underlying theory and past research), it is up to you to propose possible interpretations (Pallant, 2001, p. 154).

² To assess the confirmatory factor analysis (CFA), goodness of measurement model fit using SEM were followed (see Chapter 6, sub-section 6.14.3) (Chau, 1997, p. 318): Chi-square ($P \geq 0.05$); goodness-of-fit index ($GFI \geq 0.90$); adjusted goodness-of-fit index ($AGFI \geq 0.80$); normed fit index ($NFI \geq 0.90$); non-normed fit index ($NNFI \geq 0.90$); comparative fit index ($CFI \geq 0.90$); and root mean square error of approximation ($RMSEA < 0.10$).

labelled as “low cost strategy” (COSTSTR), “differentiation strategy” (DIFFSTR) and “innovative differentiation” (INNDIFF). All loadings³ were greater than .40, ranging from 0.77 to 0.89. The Bartlett’s test of sphericity (239, $P < 0.001$), the Kaiser-Meyer-Olkin measure of sampling adequacy 0.66 and the determinant of the correlation matrix 0.22 indicated that EFA was appropriate and within the acceptable levels (Field, 2000). In addition, the Cronbach’s alpha for COSTSTR, DIFFSTR and INNDIFF were 0.63, 0.75 and 0.48 respectively, indicating acceptable levels of reliability for COSTSTR and DIFFSTR (Hair et al., 1998) whereas for INNDIFF the level of reliability was unacceptable (see Chapter 6, sub-section 6.13.2). Therefore, it was decided to exclude the INNDIFF (items C6 and C7) from the analysis. Table 8.1 presents the dimensions of business strategy that have been used in this study.

Table 8.1 Exploratory factor analysis for business strategy

Items	Low cost	Differentiation
C4. Product selling prices	.777	
C5. Manufacturing cost	.899	
C8. Product quality		.805
C9. Brand image		.808
C10. Product features		.785

Extraction Method: Principal Component Analysis.

Rotation Method: Varimax with Kaiser Normalisation.

Rotation converged in 5 iterations.

To confirm and validate the findings that emerged from using EFA, business strategy was evaluated by CFA using EQS 5.7 software (Bentler, 1995). The measurement model of the CFA relates the observed variables to their latent variable (see Sub-section 6.14.3 in Chapter 6 for an explanation of latent variable). Figure 8.1 shows the measurement model of business strategy and a summary of the model goodness of fit. As shown in the figure, all measures of fit were met (see Table 6.12 in Chapter 6 for the criteria used). In addition, the path loadings were significant (*) (ranging from 0.50 to 0.95, t-values 5.716 to 6.791; $P < 0.001$). It should be noted from Figure 8.1 that two loadings were not significant. This is due to the measurement model identification⁴. The results emerged from CFA support the findings that emerged from EFA. Thus, business strategy is represented in this study by two dimensions. COSTSTR measured by items (C4 and C5) and DIFFSTR measured by items (C8-C10).

³ Factor loadings are the correlations of the variables with the factor, the weighted combination of variables which best explains the variance (Kline, 1994, p. 36). Higher values (e.g. more than 0.4) making the variable representative of the factor (Hair et al., 1998, p. 106).

⁴ The parameters without (*) in Figure 8.1 are specified as starting values “specified as fixed”. A starting value is needed for each of the parameters’ constructs to be estimated because the fitting algorithm involves iterative estimation, starting from a suitable approximation to the required results and proceeding to their ‘optimum’ values (Dunn et al., 1994, p. 22-24).

Figure 8.1 Confirmatory factor analysis for business strategy

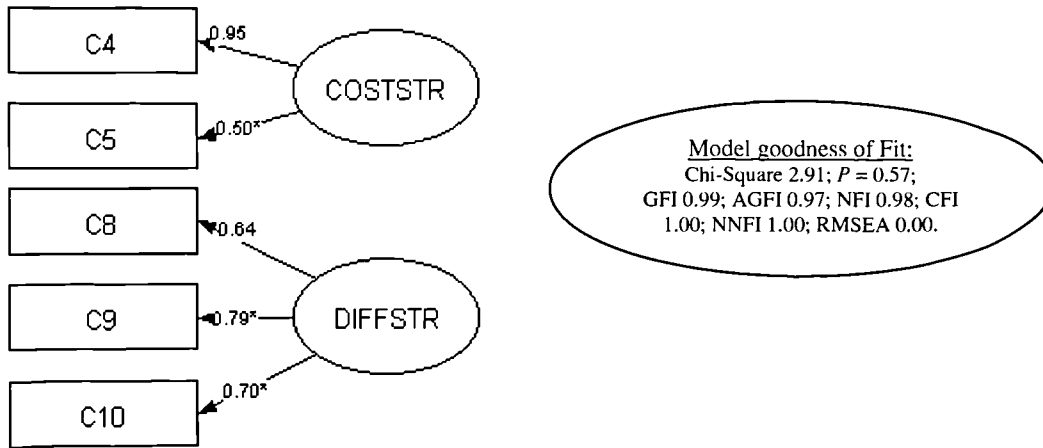

8.2.2 Organisational structure

To recall from the arguments developed in Chapter 5 (sub-section 5.4.1.2) two dimensions of organisation structure (i.e. centralisation and formalisation) are utilised in this study. These dimensions were measured with nine items adopted from Ramamurthy (1990) and Al-Dahiyate (2003). Six items measured centralisation (D1-D6), and three items measured formalisation (D7-D9). The results of EFA presented in Table 8.2 showed two factors for organisational structure explaining 56 percent of variability of this variable with eigen values greater than one. These factors were labelled “centralisation” (CENTRA) and “formalisation” (FORMAL). All loadings were greater than .40, ranging from 0.41 to 0.87.

Table 8.2 Exploratory factor analysis for organisational structure

Items	Centralisation	Formalisation
D1. New product introduction decisions are made only at the highest management level	.824	
D2. Apart from minor investments, capital budgeting decisions are usually made only at the top management level	.705	
D3. Decisions to attempt penetration into new markets generally are made only by top management	.677	
D4. Decisions on major changes (including new introduction of) manufacturing processes are made only at the top management level	.666	
D5. Personnel policy decisions are usually made by top management	.411	
D6. Pricing policies are set only by top management	.638	
D7. Rules and procedures in your business unit are very clearly documented		.801
D8. There is always an extensive reliance on rules and procedures to meet operating emergencies		.873
D9. Violation of the documented procedures is not tolerated		.872

Extraction Method: Principal Component Analysis.

Rotation Method: Varimax with Kaiser Normalisation.

Rotation converged in 3 iterations.

The Bartlett's test of sphericity (426, $P < 0.001$), the Kaiser-Meyer-Olkin measure of sampling adequacy 0.72 and the determinant of the correlation matrix 0.06 indicated that EFA was appropriate and within the acceptable levels (Field, 2000). In addition, the Cronbach's alpha for CENTRA and FORMAL were 0.75 and 0.82 respectively, indicating good levels of reliability for both factors.

To confirm and validate the findings that emerged from EFA, organisational structure was evaluated by CFA. The measurement model of the CFA relates the observed variables to their latent variable. Figure 8.2 shows the measurement model of organisational structure and a summary of the model goodness of fit. As shown in the figure, all measures of fit were met. In addition, the path loading were significant (ranging from 0.33 to 0.86, t-values 3.806 to 8.346; $P < 0.001$). Thus, organisational structure is represented in this research by two dimensions, CENTRA measured by six items (D1-D6) and FORMAL measured by three items (D7-D9).

Figure 8.2 Confirmatory factor analysis for organisational structure

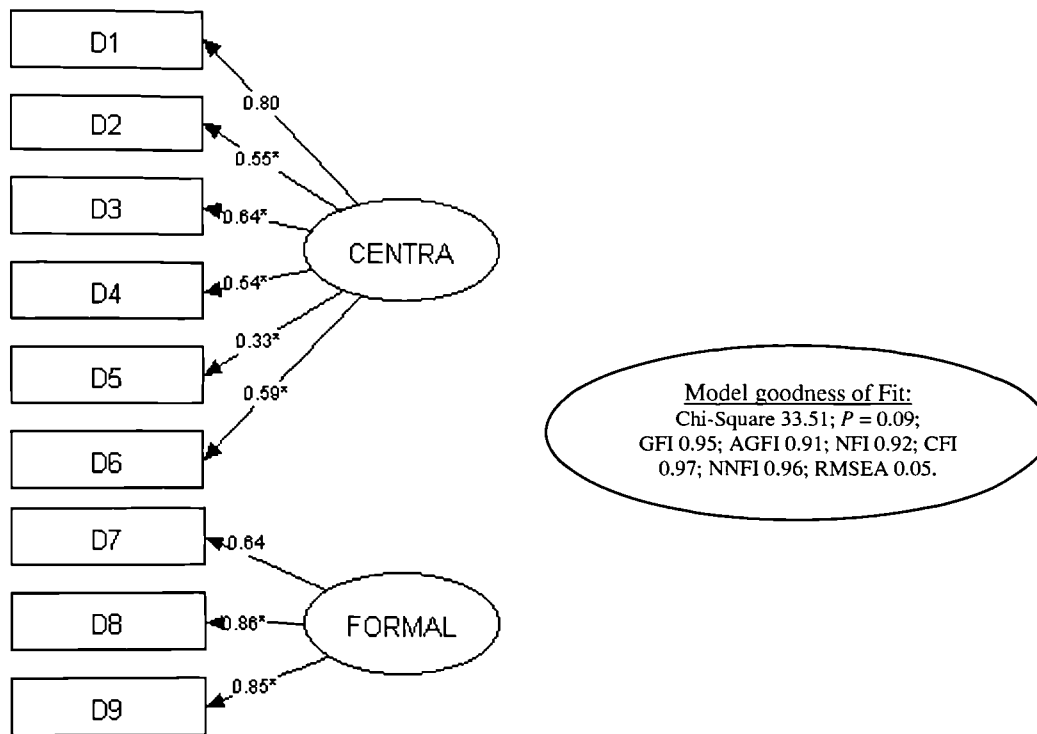

8.2.3 Perceived environmental uncertainty

It was indicated earlier in Chapter 5 (sub-section 5.4.1.3) that perceived environmental uncertainty (PEU) could be measured by different methods including internal factors (e.g.

Duncan, 1972) and external factors (e.g. Khandawalla, 1972). Several instruments to measure perceived environmental uncertainty (PEU) were developed in the literature based on Duncan's and Khandawalla's methods (e.g. Miles and Snow, 1978; Gordon and Narayanan, 1984; Govindarajan, 1984). This research measures perceived environmental uncertainty based on Govindarajan's (1984) instrument (items E1-E8) because it concentrates on external factors. Thus, a seven-point scale ranging from highly predictable to highly unpredictable rate of change was used to identify the factors of perceived environmental uncertainty.

The results of EFA presented in Table 8.3 show three factors for perceived environmental uncertainty explain 66 percent of the variability of PEU with eigen values greater than one. These factors were labelled as "operational-PEU" (OPEPEU), "raw material-PEU" (MATPEU) and "regulatory-PEU" (REGPEU). All loadings were greater than .40, ranging from 0.52 to 0.91. The Bartlett's test of sphericity (305, $P < 0.001$), the Kaiser-Meyer-Olkin measure of sampling adequacy 0.68 and the determinant of the correlation matrix 0.14 indicated that EFA was appropriate and within the acceptable levels (Field, 2000). In addition, the Cronbach's alpha for OPEPEU, MATPEU and REGPEU were 0.68, 0.73 and 0.58 respectively indicating acceptable levels of reliability (Nunnally, 1978).

Table 8.3 Exploratory factor analysis for perceived environmental uncertainty (PEU)

Items	Operational-PEU	Material-PEU	Regulatory-PEU
E1. Manufacturing technology	.801		
E2. Competitors' actions	.730		
E3. Customers' demand	.523		
E4. Product attributes/design	.752		
E5. Raw material availability		.764	
E6. Raw material price		.916	
E7. Government regulation			.787
E8. Labour union actions			.838

Extraction Method: Principal Component Analysis.

Rotation Method: Varimax with Kaiser Normalisation.

Rotation converged in 5 iterations.

The multidimensionality of PEU, which resulted from the EFA, is inconsistent with the original instrument employed in this research on the one hand, and with the commonly held belief in management accounting research that PEU is a unidimensional construct (Sharma, 2002, p. 115). In contrast, Tymon et al. (1998, p. 28) indicated that PEU is not a unidimensional construct. Thus, a confirmatory factor analysis was utilised to check the findings that emerged from EFA. Figure 8.3 shows the measurement model of PEU and a summary of the model goodness of fit. As shown in the figure, all measures of fit exceeded

the acceptable levels. Moreover, the path loading were significant (ranging from 0.41 to 0.88, t-values 4.155 to 7.280; $P < 0.001$). Thus, PEU is represented in this research by three dimensions, OPEPEU measured by four items (E1-E4), MATPEU measured by two items (E5 and E6) and REGPEU measured by two items (E7 and E8).

Figure 8.3 Confirmatory factor analysis for perceived environmental uncertainty (PEU)

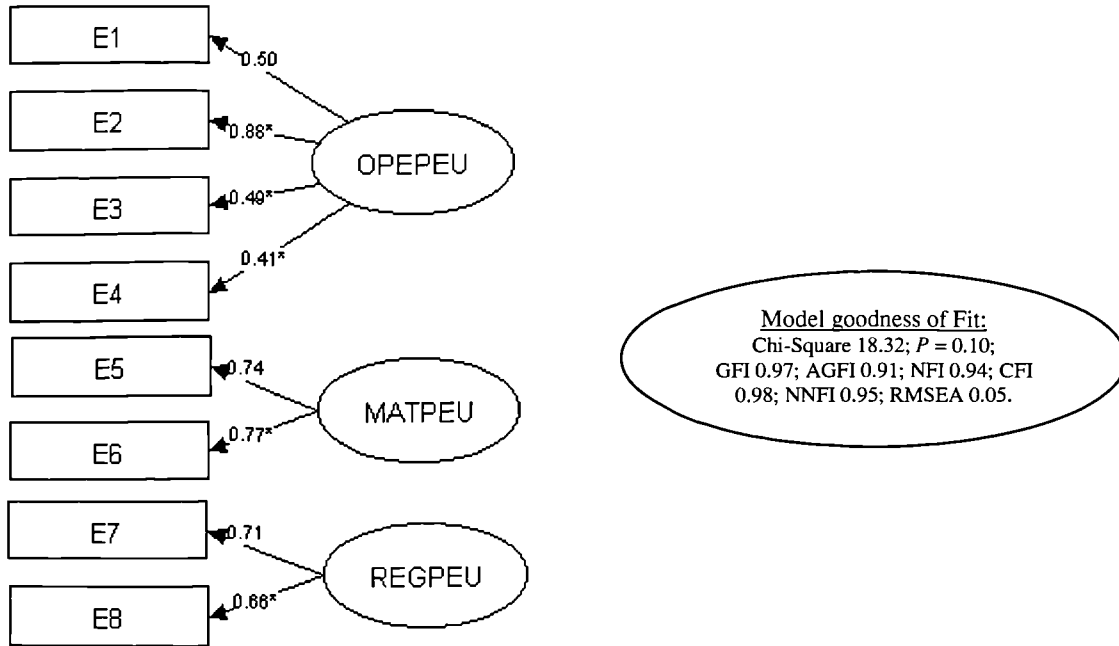

8.2.4 Intensity of competition

To recall from the argument developed in Chapter 5 (sub-section 5.4.1.4) intensity of competition was measured in this study as price, product, marketing and competitors' actions. These dimensions were measured with seven items (G1-G7) adapted from Hoque et al. (2001) and Guilding and McManus (2002). The results of EFA presented in Table 8.4 showed two factors for intensity of competition explaining 55 percent of variability of this variable with eigen values greater than one. These factors were labelled as "market competition" (MARKCOM) and "product competition" (PRODCOM). All loadings were greater than .40, ranging from 0.52 to 0.84. The Bartlett's test of sphericity (212, $P < 0.001$), the Kaiser-Meyer-Olkin measure of sampling adequacy 0.79 and the determinant of the correlation matrix 0.26 indicated that EFA was appropriate and within the acceptable levels (Field, 2000). In addition, the Cronbach's alpha for MARKCOM and PRODCOM were 0.69 and 0.68 respectively, indicating acceptable levels of reliability for both factors (Hair et al., 1998).

Table 8.4 Exploratory factor analysis for intensity of competition

Items	Market competition	Product competition
G1. Price competition	.608	
G2. Competition for selling and distribution	.584	
G4. Competition for market share	.726	
G6. Number of competitors in your market segment	.520	
G7. Competitors' actions	.783	
G3. Competition for quality and variety of products		.848
G5. Competition relating to customer service		.834

Extraction Method: Principal Component Analysis.
 Rotation Method: Varimax with Kaiser Normalisation.
 Rotation converged in 3 iterations.

To confirm and validate the findings that emerged from EFA, intensity of competition was evaluated by CFA. Figure 8.4 shows the measurement model of intensity of competition and a summary of the model goodness of fit. As shown in the figure all measures of fit were met. In addition, the path loadings were significant (ranging from 0.49 to 0.76, t-values 4.541 to 8.272; $P < 0.001$). Thus, intensity of competition is represented in this research by two dimensions, MARKCOM measured by five items (G1, G2, G4, G6 and G7) and PRODCOM measured by two items (G3 and G5).

Figure 8.4 Confirmatory factor analysis for intensity of competition

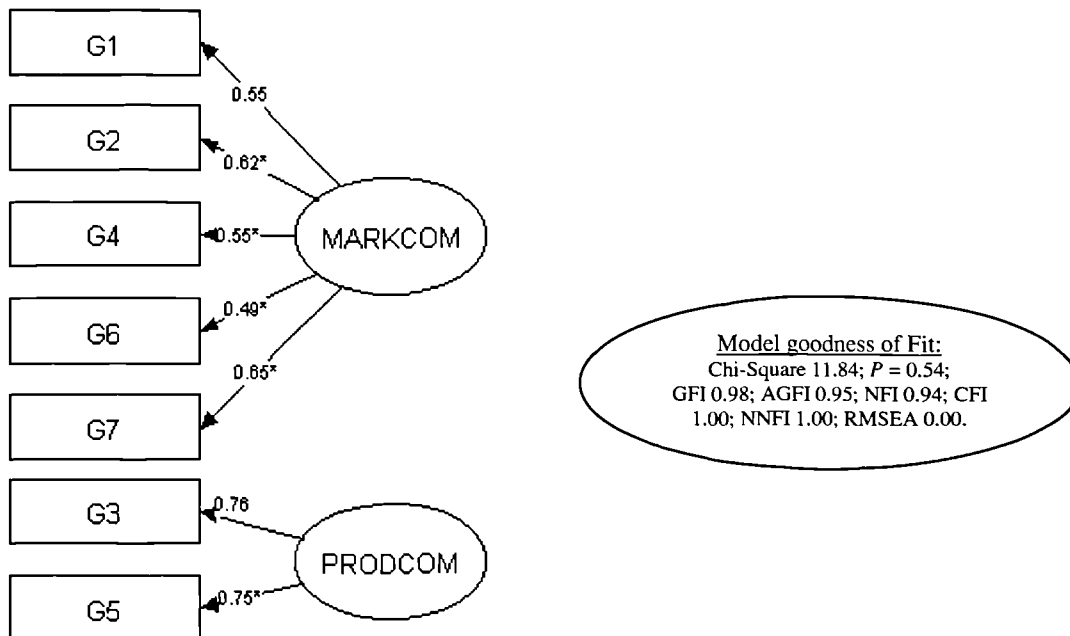

8.2.5 Organisation size

The measure for size (SIZESA) is based on the annual sales turnover for all the responding companies in the past year. However, the decision was made to transform the annual sales turnover to logarithms to adjust for both skewness and kurtosis (see Section 8.3 for an

explanation of skewness and kurtosis). An additional measure for size was included in the questionnaire (number of full time equivalents employees in the companies). The two measures for organisational size were significantly correlated (0.507, $P < 0.01$, 2-tailed) indicating that annual size turnover was an acceptable and reliable measure for size.

8.2.6 Total quality management

It was concluded in Chapter 5 (sub-section 5.4.1.6) that the implementation of quality initiatives is related to the use of non-financial performance measures. Therefore, this study opted to measure quality initiatives (items F1-F5) with the implementation of total quality management (TQM). The exploratory factor analysis showed a one-factor solution of TQM. This result showed clear discriminant validity since all items loaded on one factor. The results of EFA presented in Table 8.5 showed one factor for TQM explaining 60 percent of variability of TQM with eigen values greater than one. The factor was labelled as “total quality management” (TQM). All loadings were greater than .40, ranging from 0.69 to 0.81. The Bartlett’s test of sphericity (284, $P < 0.001$), the Kaiser-Meyer-Olkin measure of sampling adequacy 0.84 and the determinant of the correlation matrix 0.16 indicated that EFA was appropriate and within the acceptable levels (Field, 2000). In addition, the Cronbach’s alpha for TQM was 0.83 indicating good level of reliability (Hair et al., 1998).

Table 8.5 Exploratory factor analysis for total quality management (TQM)

Items	TQM
F1. Workers are awarded for quality improvement	.692
F2. Experiments to improve the quality of processes are frequently conducted	.750
F3. Quality benchmarking with other companies or business units is tracked	.816
F4. Employees teams are functioning and have been effective	.808
F5. Total quality management, whereby most business functions are involved in a process of continuous quality improvement, is an extremely high priority	.809

Extraction Method: Principal Component Analysis.

Rotation Method: Varimax with Kaiser Normalisation.

To further confirm the findings that emerged from EFA, TQM was evaluated by CFA. Figure 8.5 shows the measurement model of TQM and a summary of the model goodness of fit. As shown in the figure, all measures of fit exceeded the acceptable levels. In addition, the path loading were significant (ranging from 0.59 to 0.76, t-values 6.454 to 7.044; $P < 0.001$). These results support the findings that emerged from EFA. Thus, TQM is represented in this research by one dimension (items F1-F5).

Figure 8.5 Confirmatory factor analysis for total quality management (TQM)

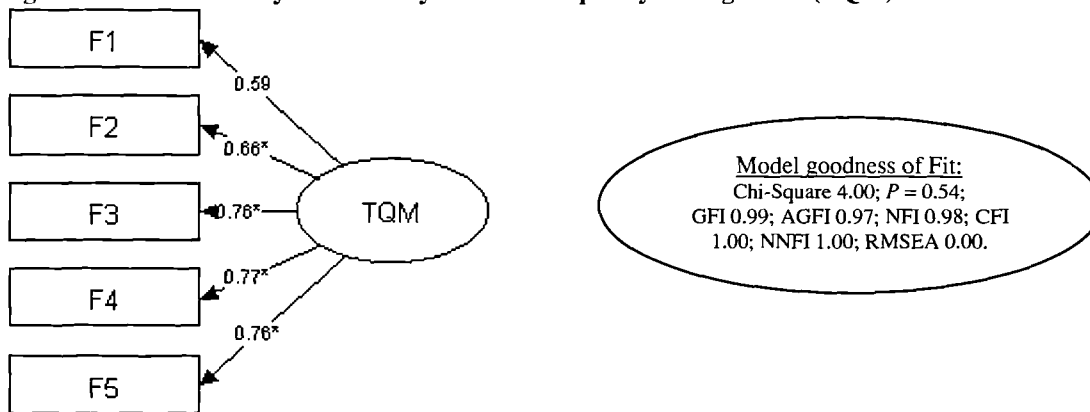

8.2.7 Just in time manufacturing approaches

To recall from the argument developed in Chapter 5 (sub-section 5.4.1.7) implementing new manufacturing approaches is associated with the use of non-financial performance measures. Therefore, this study opted to measure the implementation of just in time (JIT) as a new manufacturing approach (items F6-F10). The exploratory factor analysis showed a one-factor solution of JIT. This result showed clear discriminant validity since all items loaded on one factor. The results of EFA presented in Table 8.6 showed one factor for JIT explaining 49 percent of variability of JIT with eigen values greater than one. The factor was labelled as “just in time” (JIT). All loadings were greater than .40, ranging from 0.64 to 0.80. The Bartlett’s test of sphericity (172, $P < 0.001$), the Kaiser-Meyer-Olkin measure of sampling adequacy 0.73 and the determinant of the correlation matrix 0.33 indicated that EFA was appropriate and within the acceptable levels (Field, 2000). In addition, the Cronbach’s alpha for JIT was 0.73 indicating good level of reliability (Hair et al., 1998).

Table 8.6 Exploratory factor analysis for just in time manufacturing approaches (JIT)

Items	JIT
F6. Materials or component parts are delivered as needed rather than in large batches	.738
F7. Set-up times are frequently reduced	.802
F8. Production is automatically halted if defective work is produced	.660
F9. The plant layout is organised in flexible manufacturing cells	.641
F10. Cross-training and job rotation are required	.659

Extraction Method: Principal Component Analysis.

Rotation Method: Varimax with Kaiser Normalisation.

In addition, Figure 8.6 depicts the measurement model of JIT and a summary of the model goodness of fit. As shown in the figure, all measures of fit exceeded the acceptable levels, and the path loading were significant (ranging from 0.49 to 0.87, t-values 5.029 to 5.993; $P <$

0.001). These results support the findings emerged from EFA. Thus, JIT is represented in this research by one dimension (items F6-F10).

Figure 8.6 Confirmatory factor analysis for just in time manufacturing approaches (JIT)

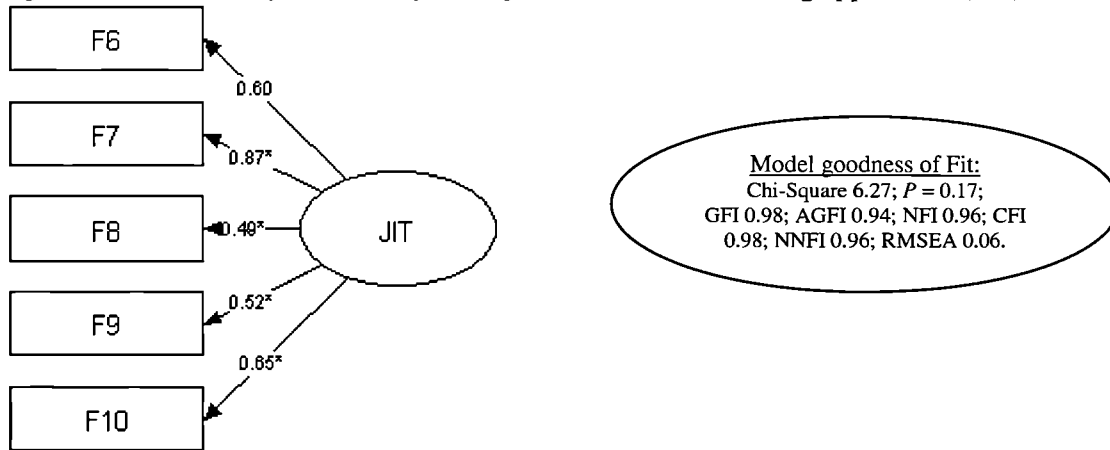

8.2.8 The extent of performance measurement diversity usage (PMD)

It was emphasised in Chapter 5 (sub-section 5.4.2) that supplementing financial performance measures with a diversity of non-financial performance measures is an essential approach of strategic performance measurement systems. To measure the extent of performance measurement diversity usage (PMD), this study depends on the responses provided by the respondents to parts 1-3 in section A of the questionnaire. The extent of PMD usage is calculated through the weighted average of the responses of all financial and non-financial performance categories across all uses (i.e. managerial performance evaluation, financial reward system, and problem identification), strategic goal setting and measurement quality⁵. The higher the value of this variable provides an indication that companies use financial and non-financial performance measures to a greater extent, set more strategic goals and have greater measurement quality for these performance measures. Thus, higher values indicate greater performance measurement diversity usage.

The results of EFA presented in Table 8.7 showed two factors for the extent of PMD usage explaining 59 percent of variability of PMD with eigen values greater than one. These factors were labelled as “the extent of performance measurement diversity usage 1” (PMD1) and “the extent of performance measurement diversity usage 2” (PMD2). All loadings were greater than .40, ranging from 0.60 to 0.82. The Bartlett’s test of sphericity (526, $P < 0.001$),

⁵ See Chapter 7 (section 7.4) for an explanation.

the Kaiser-Meyer-Olkin measure of sampling adequacy 0.84 and the determinant of the correlation matrix 0.03 indicated that EFA was appropriate and within the acceptable levels (Field, 2000). In addition, the Cronbach's alpha for PMD1 and PMD2 were 0.67 and 0.84 respectively, indicating acceptable levels of reliability (Hair et al., 1998).

Table 8.7 Exploratory factor analysis for the extent of performance measurement diversity usage (PMD)

Items	PMD1	PMD2
Financial measurement usage (FMU)	.844	
Customer measurement usage (CMU)	.749	
Innovation measurement usage (IMU)	.639	
Community measurement usage (CUMU)		.827
Environment measurement usage (ENMU)		.797
Employee measurement usage (EMMU)		.732
Quality measurement usage (QMU)		.696
Supplier measurement usage (SMU)		.685
Operational measurement usage (OMU)		.608

Extraction Method: Principal Component Analysis.

Rotation Method: Varimax with Kaiser Normalisation.

Rotation converged in 3 iterations.

To confirm and validate the findings that emerged from EFA, the extent of PMD usage was evaluated by CFA. The measurement model of the CFA relates the observed variables to their latent variable. Figure 8.7 shows the measurement model of the extent of PMD usage and a summary of the model goodness of fit. As shown in the figure, all measures of fit were met, and the path loadings were significant (ranging from 0.50 to 0.80, t-values 5.184 to 7.459; $P < 0.001$). Thus, the extent of PMD usage is represented by two dimensions, PMD1 measured by three items (FMU, CMU, and IMU) and PMD2 measured by six items (CUMU, ENMU, EMMU, QMU, SMU, and OMU) resulting from the first-order factor analysis.

In order to test the research hypotheses relating to the extent of performance measurement diversity usage (PMD), a second-order confirmatory factor analysis was conducted in which two latent variables (i.e. PMD1 and PMD2) define one latent variable (i.e. PMD). In this context, Schumacker and Lomax (1996) indicated that latent variables can be unidimensional, correlated, or defined as a higher-order latent variable. Thus, Figure 8.8 shows the measurement model of the extent of PMD usage and all the goodness-of-fit measures exceeded the recommended cut-off values (Chi-square 25.43, $P = 0.32$; GFI 0.96; AGFI 0.93; NFI 0.95; CFI 0.99; NNFI 0.99; RMSEA 0.02), and the path loadings were significant. These results support the findings that emerged from EFA, first-order confirmatory factor analysis and second-order confirmatory factor analysis. Therefore, performance measurement diversity usage (PMD) is represented in this research by one dimension.

Figure 8.7 Confirmatory factor analysis for the extent of performance measurement diversity usage (PMD)

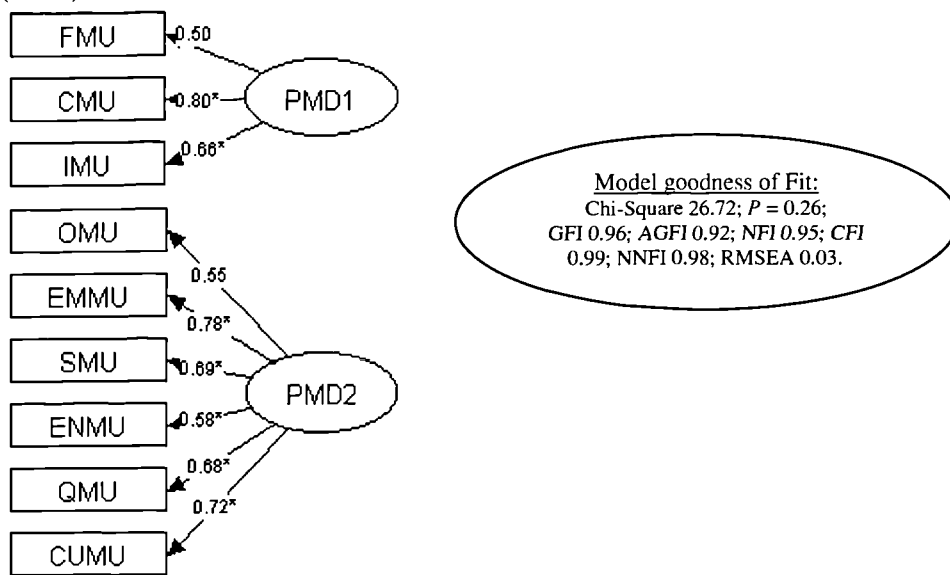
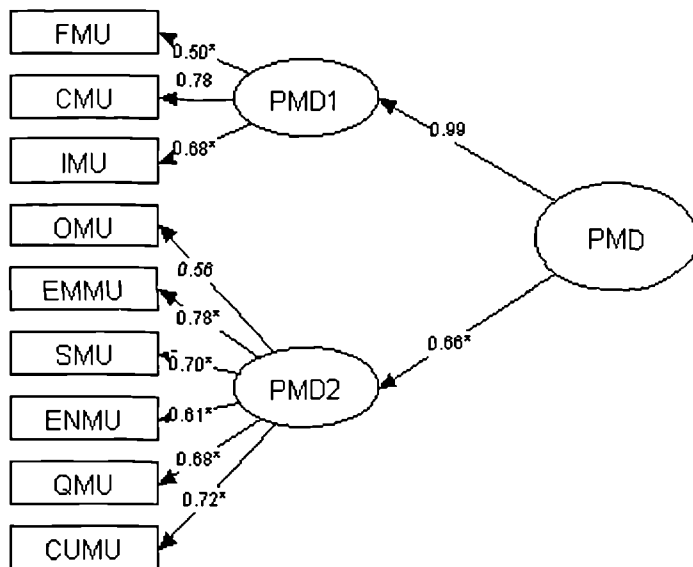

Figure 8.8 Second-order confirmatory factor analysis for the extent of performance measurement diversity usage (PMD)



8.2.9 The extent of balanced scorecard usage (BSCUSE)

It was pointed out in Chapter 5 (sub-section 5.4.3) that the conceptualisation of the extent of balanced scorecard usage is problematic and that the literature lacks an optimal way to determine the degree to which balanced scorecard has been implemented by companies. However, several researchers (e.g. Ittner, Larcker and Randall, 2003; Nielsen and Sorensen, 2003) have measured the level of usage of balanced scorecards in their surveys by asking the respondents to self-specify whether their companies operated a balanced scorecard in their performance measurement system. Other researchers (e.g. Hoque and James, 2000) have

measured the level of usage of balanced scorecard in their surveys by asking the respondents to indicate the extent to which several financial and non-financial performance measures were used based on Kaplan and Norton original four perspectives.

Given the importance of balanced scorecard studies, this research adapts, integrates and updates aspects of the above two streams of studies in order to provide a more coherent measure for the extent of balanced scorecard usage. The reason for developing a measure for the extent of balanced scorecard usage is to overcome the disadvantages of the most widely used approach that is used to measure the balanced scorecard adoption and other management accounting innovation adoptions. This approach treats the adoption of an innovation as a categorical dichotomy (i.e. balanced scorecard users and non-users) thus treating interventions in different companies as homogeneous even though such interventions may differ substantially with respect to degree and breadth of implementation (Schoute, 2002). In this context, Shields (1998) argued that the innovations being used by companies may differ substantially in terms of architecture, purposes and styles of use⁶.

Given that this measure has been used in previous studies, the logistic regression model was performed to examine the statistical differences in the responses for balanced scorecard users and non-users. The output of the logistic regression model indicates that the chi-square statistic is not significant ($P > 0.05$) and the Hosmer and Lemeshow value is significant ($P < 0.05$). This result according to Hair et al. (1998) and Field (2000) indicates that the model does not differ significantly from the observed data, thus the logistic regression model is not suitable. Therefore, it was inappropriate to measure the extent of balanced scorecard usage as a categorical dichotomy.

An alternative method to measure the extent of balanced scorecard usage is as a continuous variable. In this context, Schoute (2002) argued that measuring management accounting innovation as a continuous variable is only relevant if the company is actually using the innovation. Thus, in order to determine if the responding companies are balanced scorecard users, the following initial steps were taken to ensure that the responding companies are really balanced scorecard users:

⁶ For example, the results presented in Chapter 7 (sub-section 7.5.1) show that the balanced scorecard companies (N = 49) use different types of performance perspectives.

- Question B1 was formulated to capture the stages relating to the balanced scorecard current situation in the companies.
- Question B2 contained eight potential types of perspectives that may be used within the balanced scorecard.
- Also, several efforts were made to ensure that the responding companies are balanced scorecard users. These include comparing the responses from question B1 with the responses obtained from questions A28 and A29 which represent the main attributes of the balanced scorecard.

Several management accounting researchers (e.g. Otley, 1999; Malmi, 2001) advocate setting strategic targets to balanced scorecard performance measures. Other researchers (e.g. Speckbacher et al., 2003; Wongrassamee et al., 2003) advocate linking reward system and managerial performance evaluation to the balanced scorecard performance measures and using action plans for business strategy implementation. Moreover, researchers (e.g. Krumwiede, 1999) argue that balanced scorecard companies appear to have higher quality information system. Therefore, of the 163 responding companies with performance measurement systems, 49 companies were classified as balanced scorecard users.

For the purpose of measuring the extent of balanced scorecard usage for each company, the following procedures were taken: First, the types of financial and non-financial perspectives were determined throughout the responses obtained from question B2 in the questionnaire. Second, to check if the types of perspectives (see Chapter 7, sub-section 7.5.1) obtained from question B2 are really used by the responding companies, the weighted average usage of these perspectives were calculated from the responses obtained in section A. Therefore, the extent of balanced scorecard usage is calculated using the same approach to compute PMD by computing the weighted average of the responses of the performance perspectives across all uses: (i.e. managerial performance evaluation, financial reward system, problem identification), strategic goal setting and measurement quality. With this procedure, it is possible to determine the extent of balanced scorecard usage for each company based on their usage of the perspectives identified in question B2. Besides, it should be noted that this measure of balanced scorecard might pick up both the tendency to use financial and non-financial performance measures and the strategic linkages of the real balanced scorecard usage based on the responses obtained from questions A28-A29.

Finally, it was pointed out in Chapter 6 (sub-section 6.14.4) that correlation and multiple regression was utilised in this research to test the hypotheses relating to the contingent variables that may affect the extent of balanced scorecard usage. Thus, the current measure of extent of BSC usage is appropriate for using multiple regression because of its metric nature.

8.2.10 Organisational effectiveness

It was pointed out in Chapter 5 (sub-section 5.4.4) that there is no ideal measure for organisational effectiveness. However, two variables were used in this study to assess organisational effectiveness. These are:

- **Organisational performance (i.e. financial and non-financial metrics):** Following Govindarajan (1984), a two-stage scale approach was used. First, respondents were asked to rate the importance of eight performance measures to their organisations (items H4i-H11i in the questionnaire). Second, respondents were asked to rate how they perceived their organisations actually performed along each of the eight performance measures (items H4ii-H11ii in the questionnaire). To arrive at a measure of overall organisational performance, the weighted average⁷ for each importance scale was calculated and added to the actual performance for each responding company. To test for the validity of this variable (i.e. organisational performance), the correlation coefficient was used, where high and significant correlation indicates the presence of validity⁸ (Oppenheim, 1992). Thus, two steps were used to assess the validity of this instrument. First, a correlation coefficient between the importance weighting (items H4i-H11i) and actual performance (items H4ii-H11ii) showed that these items correlated highly and were significant (0.608, $P < 0.01$; 2-tailed). Second, the respondents were asked in a separate item (H12ii) to indicate the overall performance of their business units compared to their competitors over the last three years. The correlation coefficient between this item and the average overall performance (items H4ii-H11ii) showed that this item correlated highly and significantly with the average actual performance score (0.766, $P < 0.01$; 2-tailed). As a result, the instrument used to measure organisational performance can be assumed to be valid. Thus, organisational performance is represented in this research by one dimension.

⁷ The weighted average for each importance scale = item score/total of all importance scores.

⁸ This method of establishing validity requires correlating the scores with other measures of the variable (Oppenheim, 1992, p. 160).

- Level of satisfaction: Following Ittner, Larcker and Randall (2003) three questions are used to measure company's satisfaction with its performance measurement system (Questions H1-H3 in the questionnaire). The exploratory factor analysis showed a one-factor solution for the responses relating to the satisfaction with the performance measurement system. This result showed clear discriminant validity since all items loaded on one factor. The results of EFA presented in Table 8.8 showed one factor for satisfaction explaining 86 percent of variability of satisfaction with eigen values greater than one. The factor was labelled as "satisfaction" (SATISFAC). All loadings were greater than .40, ranging from 0.92 to 0.94. The Bartlett's test of sphericity (364, $P < 0.001$), the Kaiser-Meyer-Olkin measure of sampling adequacy 0.76 and the determinant of the correlation matrix 0.1 indicated that EFA was appropriate and within the acceptable levels (Field, 2000). In addition, the Cronbach's alpha for SATISFAC was 0.92 indicating good level of reliability (Hair et al., 1998).

Table 8.8 Exploratory factor analysis for satisfaction

Items	Satisfaction
H1. How well the performance measurement system of your business unit currently meets expectations	.926
H2. How well the performance measurement system of your business unit compares to your understanding of the concept of an "ideal" system	.927
H3. The overall satisfaction with the performance measurement system of your business unit	.940

Extraction Method: Principal Component Analysis.

Rotation Method: Varimax with Kaiser Normalisation.

In addition, Figure 8.9 shows the measurement model of satisfaction and a summary of the model goodness of fit. The figure shows a perfect fit⁹, and the path loading were significant (ranging from 0.88 to 0.92, t-values 15.433 to 16.386; $P < 0.001$). These results support the findings that emerged from EFA. Thus, level of satisfaction is represented in this research by one dimension (H1-H3).

⁹ A (X^2) value of zero, which would result from a value of the fitting function equal to zero (i.e. the residual matrix would contain all zeros), indicates a perfect fit (Hoyle, 1995, p. 7).

Figure 8.9 Confirmatory factor analysis for satisfaction

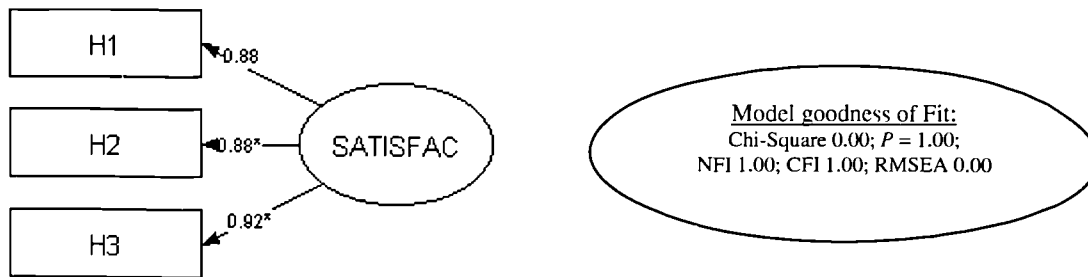

8.3 Descriptive statistics for research variables

It was pointed out in Chapter 5 that this research aims to investigate the relationship between the contingent variables and three dependent variables (i.e. the extent of performance measurement diversity usage, the extent of balanced scorecard usage and the effectiveness of performance measurement diversity usage). Thus, three sets of hypotheses were formulated to examine the relationship between the contingent variables and the dependent variables. Table 8.9 presents the descriptive statistics for the research variables relating to the first set of hypotheses to examine the relationship between the contingent variables and the extent of performance measurement diversity usage. Table 8.9 also represents the descriptive statistics related to the second set of hypotheses to examine the impact of fit ‘internal consistency’ between the contingent variables and the extent of performance measurement diversity usage on organisational effectiveness. The results of the descriptive statistics presented in Chapter 7 (section 7.5) also show that 49 companies were balanced scorecard users. Thus, Table 8.10 presents the descriptive statistics for the research variables relating to the third set of hypotheses to examine the relationship between the contingent variables and the extent of balanced scorecard usage. Both tables include the mean as measure of central tendency, standard deviation as measure of spread of distribution, minimum and maximum values, and skewness¹⁰ and kurtosis¹¹ values to check for normality¹² of each variable. According to Hair et al. (2003, p. 244), skewness values within the range of –1 to +1 and kurtosis values within

¹⁰ Skewness is a measure of symmetry of a distribution. A positively skewed distribution has relatively few large values and tails off to the right, and a negatively skewed distribution has relatively few small values and tails off to the left (Hair et al., 1998, p. 38).

¹¹ Kurtosis is a measure of the peakedness or flatness of a distribution when compared with a normal distribution. A positive value indicates a relatively peaked distribution, and a negative value indicates a relatively flat distribution (Hair et al., 1998, p. 37).

¹² Normality refers to the degree to which the distribution of the sample data corresponds to a normal distribution. Where normal distribution is a theoretical probability distribution in which the horizontal axis represents possible values of a variable and the vertical axis represents the probability of those values occurring. The scores on the variable are clustered around the mean in a symmetrical, unimodal pattern known as the bell-shaped or normal curve (Hair et al., 1998, p. 38).

-3 to +3 indicate an acceptable range for normality whereas values falling outside the range of skewness and kurtosis indicate a substantial departure from a normal distribution. Thus, Tables 8.9 and 8.10 show that skewness and kurtosis values for all variables fall within the acceptable range.

Table 8.9 Descriptive statistics for research variables relating to the extent of performance measurement diversity usage (N = 163)

Research variables	Mean	Std.Dev	Min	Max	Skewness	Kurtosis
Low cost strategy (COSTSTR)	3.641	0.882	1	6	0.121	0.241
Differentiation strategy (DIFFSTR)	5.110	0.845	1.67	7	-0.535	0.962
Centralisation (CENTRA)	5.427	0.913	2.83	7	-0.639	-0.144
Formalisation (FORMAL)	4.388	1.3	1	7	-0.303	-0.307
Operational-PEU (OPEPEU)	3.296	1.063	1.25	6	0.331	-0.501
Raw material-PEU (MATPEU)	3.214	1.293	1	6.5	0.530	-0.601
Regulatory-PEU (REGPEU)	3.343	1.128	1	6.5	0.031	-0.367
Market competition (MARKCOM)	5.033	0.871	2	6.60	-0.658	1.014
Product competition (PRODCOM)	4.914	1.057	1.50	7	-0.714	0.535
Organisation size (SIZESA)	2.01	0.342	1.15	3.00	0.779	0.828
Total quality management (TQM)	4.547	1.211	1.40	6.80	-0.434	-0.412
Just in time manufacturing approaches (JIT)	4.262	1.197	1.40	7	-0.284	-0.225
Performance measurement diversity (PMD)	4.230	0.757	2.27	6.29	0.306	-0.120
Satisfaction (SATISFAC)	4.235	1.064	1	6.33	-0.507	0.149
Effectiveness (EFFECT)	4.691	0.757	2.38	6.38	-0.615	0.953

Table 8.10 Descriptive statistics for research variables relating to the extent of balanced scorecard usage (N = 49)

Research variables	Mean	Std.Dev	Min	Max	Skewness	Kurtosis
Low cost strategy (COSTSTR)	3.551	0.947	1	6	-0.191	1.005
Differentiation strategy (DIFFSTR)	5.299	0.820	3.33	7	-0.140	-0.030
Centralisation (CENTRA)	5.444	0.890	3	7	-0.865	0.556
Formalisation (FORMAL)	4.748	1.313	1	7	-0.640	0.693
Operational-PEU (OPEPEU)	3.362	1.023	1.25	5.50	0.193	-0.453
Raw material-PEU (MATPEU)	3.459	1.215	1.50	6	0.308	-0.591
Regulatory-PEU (REGPEU)	3.489	1.243	1	6.50	0.151	-0.456
Market competition (MARKCOM)	4.889	1.019	2	6.60	-0.550	0.559
Product competition (PRODCOM)	4.867	0.998	2	7	-0.811	1.111
Organisation size (SIZESA)	2.056	0.348	1.60	3	0.997	0.162
Total quality management (TQM)	4.836	1.323	1.40	6.60	0.656	-1.091
Just in time manufacturing approaches (JIT)	4.355	1.111	1.40	6.80	-0.145	0.664
Balanced scorecard usage (BSCUSE)	5.249	0.657	4.04	6.55	0.041	-0.848

8.4 Statistical methods used for testing research hypotheses

Several statistical methods were utilised in this research, however, the decision was made to use parametric tests for testing the research hypotheses (see Chapter 6, section 6.14 for an explanation). Three sets of hypotheses were formulated, first, hypotheses relating to the relationships between the contingent variables and the extent of performance measurement diversity usage, second, hypotheses relating to the fit (i.e. internal consistency) between the contingent variables, the extent of performance measurement diversity usage and organisational effectiveness, third, hypotheses relating to the relationship between the contingent variables and the extent of balanced scorecard usage. Thus, two statistical methods¹³ (i.e. structural equation modelling and multiple regression) were utilised in this research in order to test the research hypotheses. Structural equation modelling (SEM) is utilised to examine the first and second sets of research hypotheses whereas correlation and multiple regression methods are utilised to examine the third set of hypotheses. The rationale for utilising correlation and multiple regression methods instead of SEM to test the third set of hypotheses is due to the limited sample size (N = 49) for the companies who claimed using the balanced scorecard. SEM techniques require a fairly large sample (recommended minimum of 100) for a reliable analysis, which is sometimes hard to obtain in management accounting research when the research focuses on the usage of innovative practices (Sharma, 2002, p. 117). Given the importance of structural equation modelling, it is useful to explain and present its assumptions before testing the hypotheses. These are presented in the following sub-section. The assumptions of multiple regression analysis are presented in Chapter 9 section 9.4.

8.4.1 Structural equation modelling assumptions

According to Hoyle (1995, p. 14) and Hair et al. (1998, p. 601), SEM shares certain assumptions with other multivariate approaches: independence of observations, random sampling of respondents and multivariate normality. Thus, SEM is sensitive to the departure from multivariate normality (i.e. strong kurtosis or skewness in the data). A lack of normality is problematic because it substantially inflates the chi-square statistics and then creates bias in the values of coefficient significance. Therefore, researchers should perform the diagnostic tests on the data before they are used in the estimation procedure (Hair et al., 1998, p. 601-

¹³ The justifications for utilising these statistical methods were presented in Chapter 6.

603). However, a violation of normality assumption has led to a growing interest in developing alternative remedial strategies. In this context, West et al. (1995, p. 64) and Byrne (1995, p. 147) suggested two remedies for the problem of non-normality. One approach to resolving the problem is the development and use of asymptotic (large-sample) distribution-free estimation method (ADF). The second approach is to use an estimation method that assumes the data are normally distributed, but when evaluating the model goodness-of-fit the researchers should base their evaluation on a statistic test called the SCALED X^2 and robust standard error. As shown in Table 8.9, all the research variables based on the values of skewness and kurtosis are within the acceptable range. Thus, the maximum likelihood estimation (MLE) method is used in this research for evaluating the model goodness-of-fit (see Chapter 6, sub-section 6.14.3 for an explanation of MLE).

8.4.2 Structural equation modelling computer programs

When the maximum likelihood estimation technique is selected, it is crucial at this stage to determine the most appropriate SEM software program to estimate the model (Hair et al., 1998). Several SEM programs exist and most of them are run on either the DOS or windows environment. These programs according to Schumacker and Lomax (1996) are AMOS/AMOSDraw, CALIS, EQS, LISREL, LISCOMP, Mx, and SEPATH. In this study, EQS 5.7 software program was utilised for analysing the data. The rationale for using the EQS 5.7 by this research is due to the following:

- It provides several goodness-of-fit indices.
- It is simple to code and easy to understand (Schumacker and Lomax, 1996, p. 50).
- It is unique in its ability to identify multivariate outliers (Byrne, 1995, p. 146).
- It places less stringent assumptions on the multivariate normality of the data (Hair et al., 1998, p. 607).
- It enables users to do robust statistics with all the estimation methods when the assumptions of multivariate normality are violated (Byrne, 1995, p. 148).

8.4.3 Dealing with outliers and missing data

Outliers are extreme data that may affect the results of SEM. These cases occur because of errors in responding by subjects or data recording errors (West et al., 1995, p. 61). In addition, outliers can potentially have effects on the indices of model goodness-of-fit,

parameter estimates and standard errors (Schumacker and Lomax, 1996). However, possible corrective actions for outliers are recommended in the literature. For instance, West et al. (1995) recommend dropping the extreme case, redefinition of the population of interest, or respecification of the model. The EQS programme utilised in this research is able to identify outliers and prints out the five cases that contribute to multivariate kurtosis (Schumacker and Lomax, 1996, p. 6). If the results show that one of these cases have large estimates, then the outlier should probably be deleted. In this research only one case was identified as an outlier and thus was deleted. Details of these procedures are provided in the next chapter.

Missing data is a common problem that often faces researchers and this problem is also associated with other statistical analysis besides structural equation modelling (Schumacker and Lomax, 1996). A number of ways of dealing with the problem of missing data were identified in the literature. A deletion of the cases or variables that have missing data is the simple way, but this may affect the sample size (Hair et al., 1998). Mean substitution is one of the most widely used remedial approaches for solving the problem of missing data because the mean is the best single replacement value (Hair et al., 1998, p. 54). This approach replaces the missing values for a case or variable with the mean value based on all valid responses. In this research, four cases were identified with missing data which came from sections D and F in the questionnaire. Due to the limited sample size, the researcher opted to use the mean substitution method to deal with the problem of missing data.

Finally, it should be noted that the results of SEM can be affected by multicollinearity, and researchers should be aware of the correlations among the variables (Hair et al., 1998). A correlation exceeding 0.80 can be indicative of problems, although no limit has been set that defines what are considered as high correlations (Hair et al., 1998, p. 613). Checking the correlations among the independent variables shows that the highest correlation was 0.48 thus indicating no multicollinearity problem. In addition, the EQS program provides error message if there is multicollinearity between variables (Chou and Bentler, 1995).

8.4.4 The structural model goodness-of-fit evaluation

The determination of model goodness-of-fit in SEM is not as straightforward as with other multivariate statistical approaches (Schumacker and Lomax, 1996). Moreover, it should be noted that SEM has no single statistical test that best describes the strength of the model's

predictions. Instead, researchers have developed a number of goodness-of-fit measures that when used in combination, assess the results from three perspectives: overall fit (e.g. chi-square, GFI, and RMSEA), comparative fit (e.g. NNFI, CFI), and model parsimony (e.g. normed fit index) (Hair et al., 1998, p. 653). Thus, similar fit indices to those presented in Chapter 6 (sub-section 6.14.3) and used in confirmatory factor analysis (see Section 8.2) were utilised to assess the model goodness-of-fit for testing the research hypotheses. They included chi-square, GFI, AGFI, NFI, CFI, NNFI, and RMSEA.

8.4.5 Statistical significance of parameters estimates

The most obvious examination of SEM involves the significance of estimated coefficients (Hair et al., 1998). An overall coefficient of determination (R^2) is calculated as a measure of the entire structural equation. This coefficient determines the predictive power of the structural equation and represents the variance explained in the dependent variable. In addition, SEM provides another aspect for evaluating the estimated relationships. The standardised coefficient (beta) is a means for testing the hypothesised relationship between independent and dependent variables (Field, 2000). Standardised coefficients enable researchers to compare the parameters in the model in order to determine those independent variables that have greater effects on the dependent variables (Hoyle, 1995).

Moreover, SEM provides calculated t-values for each coefficient based on the level of significance (α). In this research, the decision was made to adopt the traditional level of significance ($\alpha = 0.05$). The selection of a critical value also depends on the proposed relationships between variables. In this context, Hair et al. (1998, p. 613) state that:

If a positive or negative relationship is hypothesized, then a one-tailed test of significance can be employed. However, if the researcher cannot pre-specify the direction of the relationship, then a two-tailed significance test must be used.

The critical t-values can be expressed based on the type of test. Apart from organisational structure, directional relationships are hypothesised to address the effect of contingent variables on the extent of performance measurement diversity usage. Therefore, a one-tailed test of significance was used whereas a two-tailed test of significance was used to examine the effect of organisational structure on the extent of performance measurement diversity usage. For the 0.05 significance level, the critical t-values are above 1.645 for a one-tailed test and above 1.96 for a two-tailed test.

8.4.6 Sample size and model complexity

One common feature of multivariate techniques is that there is no single correct way to apply them. Instead, researchers formulate the objectives and apply the appropriate technique, which may include the application of structural equation modelling (Hair et al., 1998, p. 590). Sample size plays an essential role in the estimation and interpretation of SEM results. According to Hair et al. (1998, p. 604-605), there are at least four factors that impact the sample size requirements: (1) model misspecification, (2) model size, (3) the departure from normality, and (4) the estimation procedure utilised.

Model misspecification, refers to the extent that the model suffers from specification error (i.e. the omission of relevant variables from the specified model). However, all structural equation models suffer from specification error because every indicator cannot be included. Considering the model size, the definite minimum sample size that must be at least greater than the number of covariance in input matrix. In this context, Hair et al. (1998, p. 182) argue that several rules of thumb have been proposed, ranging from 10 to 15 observations per independent variable to an absolute minimum of 4 observations per independent variable. These rules would increase as the model complexity increased. As for the departure from normality, researchers are always encouraged to increase the sample size. The ratio of respondents to parameters needs to increase with a generally accepted ratio of 15 respondents for each parameter. Finally, it was pointed out in Chapter 6 that maximum likelihood estimation (MLE) is the most common estimation procedure that provides valid results with small sample sizes. However, it is generally accepted that the minimum sample size to ensure appropriate use of MLE is 100 to 150.

It should be noted at this stage that there are two methods for incorporating the independent and dependent variables in structural equation modelling (Ruyter and Wetzels, 1999). The first method is to use a latent variable model with all indicators (i.e. all items that represent the variable) in the structural model. The second method is to use an aggregate model where all indicators for each variable are constructed in one construct. In this context, several researchers (e.g. Bentler and Chou, 1987; Bagozzi and Heatherton, 1994; Baumgartner and Homburg, 1996) have argued that a latent variable model (first method) with multiple indicators might not be very helpful, since model complexity in terms of the number of constructs and/or indicators might prevent the researcher from finding a model fitting to the data (quoted in Ruyter and Wetzels, 1999, p. 65).

In addition, Ruyter and Wetzels (1999) argued that the two methods basically produce the same results. Thus, composite scales method (second method) was used to reduce the complexity of the model. This method requires multi-item measures for each variable being summed and the total being used as a single-item indicator for the variable (Hair et al., 1998). Measurement error variances can however be estimated from reliability estimates and therefore incorporated into the structural model whereby the measurement error variance of each summated scale¹⁴ for each variable is fixed at 1 minus the value of reliability coefficient (Ruyter and Wetzels 1999; Steenkamp and Baumgartner, 2000). In this context, Hair et al. (1998, p. 586) argue that researchers may incorporate the reliability into the statistical estimation to improve the model. For variables that have two or more indicators the estimation of reliability is possible, while, for variables with only one indicator, the researcher should specify the reliability (Hair et al., 1998). In this study, measurement error terms for single-item variables (i.e. the extent of performance measurement diversity usage, organisation size, and organisational performance) were set at 0.20. In this context, Singhapakdi et al. (1999, p. 27) state that:

The implied reliability value of 0.80 is a more conservative arbitrary value than the 0.85 value recommended by Joreskog and Sorbom (1982) for estimating measurement error in single-item measures.

Due to the model complexity in terms of the number of independent variables and parameters to be estimated and the limitations of the sample size (as recommended by Hair et al., 1998), the model size required at least a minimum of five observations for each estimated parameter. The general hypothesised model shown in Figure 8.10 was divided into 12 sub-models where every independent variable (i.e. COSTSTR, DIFFSTR, CENTRA, FORMAL, OPEPEU, MATPEU, REGPEU, TQM, JIT, PRODCOM, MARKCOM, and SIZESA) is placed separately in a single sub-model based on the hypothesised relationship between these independent variables and the dependent variable (PMD)¹⁵. The second stage of the structural analysis tests the fit or internal consistency between the independent variables and the extent of performance measurement diversity usage (PMD) on organisational effectiveness (i.e. organisational performance and level of satisfaction).

¹⁴ Method of combining several variables that measure the same concept into a single variable in an attempt to increase the reliability of the measurement through multivariate measurement. In most instances, the separate variables are summed and then their total or average score is used in the analysis (Hair et al., 1998, p. 3).

¹⁵ Even though the PMD was represented in Figure 8.10 with two dimensions, the PMD was measured as one construct based on the result emerged from conducting second-order confirmatory factor analysis (see Sub-section 8.2.8 for an explanation).

Figure 8.10 The overall structural model for testing the first set of research hypotheses

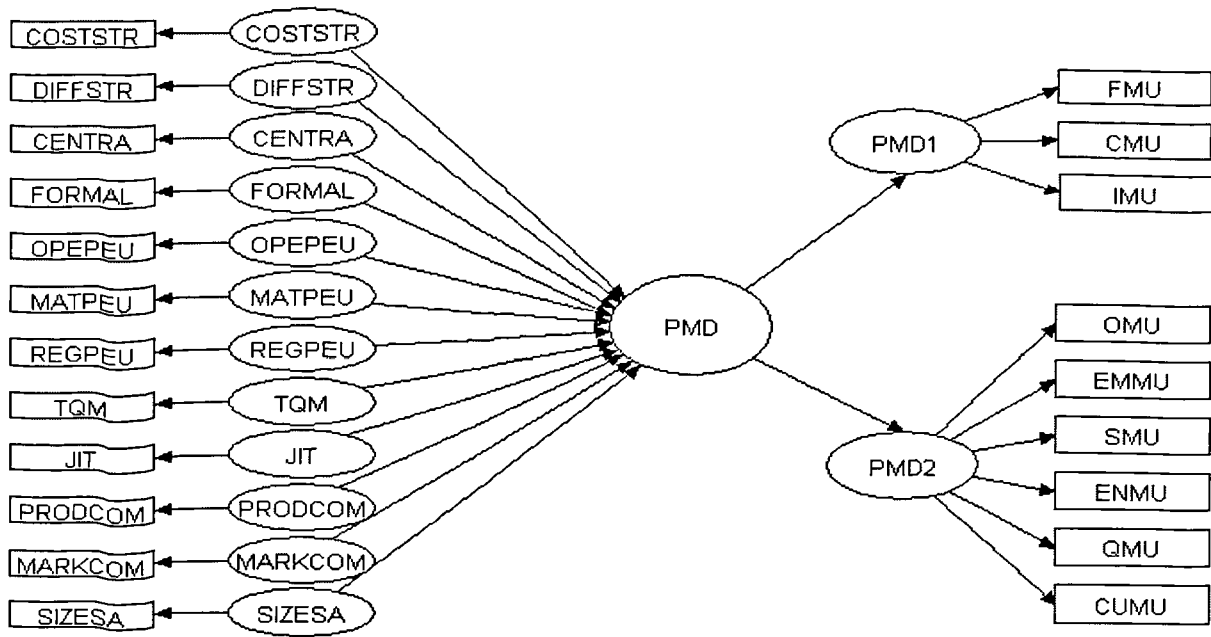

8.4.7 The variables used in testing research hypotheses

To recall from our discussion in section 8.3, three sets of hypotheses were formulated to achieve the second, third and fifth objectives of this research (see Chapter 5, section 5.3). However, the following are the constructs used in testing the three sets of hypotheses:

- Business strategy construct consists of cost strategy (COSTSTR) and differentiation strategy (DIFFSTR).
- Organisational structure construct consists of centralisation (CENTRA) and formalisation (FORMAL).
- Perceived environmental uncertainty construct consists of operational-PEU (OPEPEU), raw material-PEU (MATPEU) and regulatory-PEU (REGPEU).
- Total quality management construct (TQM).
- Just in time manufacturing approaches construct (JIT).
- Intensity of competition construct consists of product competition (PRODCOM) and market competition (MARKCOM).
- Organisation size construct (SIZESA).
- The extent of balanced scorecard usage (BSCUSE)
- The extent of performance measurement diversity usage (PMD) construct is divided into the following two dimensions:
 - The extent of performance measurement diversity usage 1 (PMD1). This variable is divided into three dimensions based on the factor analysis output: financial

measurement usage (FMU); customer measurement usage (CMU); and innovation measurement usage (IMU).

- The extent of performance measurement diversity usage 2 (PMD2). This variable is divided into six dimensions based on the factor analysis output: operational measurement usage (OMU); employee measurement usage (EMMU); supplier measurement usage (SMU); environment measurement usage (ENMU); quality measurement usage (QMU); and community measurement usage (CUMU).
- Organisational effectiveness construct is divided into the following two dimensions:
 - Organisational performance (EFFECT).
 - Level of satisfaction (SATISFAC).

8.5 Summary

This chapter has presented the measurement model analysis of the research variables using both exploratory and confirmatory factor analysis. Summary descriptive statistics of the research variables were presented including the skewness and kurtosis values in order to check for normality. The major features of structural equation modelling that will be utilised to test the first research theoretical model depicted in Figure 5.1 were presented. The model will be used to investigate the impact of the contingent variables on the extent of performance measurement diversity usage (PMD), and the coalignment effect of the contingent variables and PMD on organisational effectiveness. EQS version 5.7 was utilised for performing the structural model since it provided the goodness-of-fit indices required for the acceptance of measurement model. It was pointed out that the maximum likelihood estimation (MLE) was adopted in this research to estimate the model relationships. Also, the summated scale approach was adopted due to the model complexity in terms of a number of variables and parameters to be estimated, and the limitations of the sample size. The general hypothesised model shown in Figure 8.10 will be divided into 12 sub-models where every contingent variable is placed separately each in a single sub-model. Due to the limited sample size, it was pointed out that correlation and multiple regression is utilised to test the second research theoretical model depicted in Figure 5.2 by investigating the impact of the contingent variables on the usage of the balanced scorecard. The results of structural equation modelling as well as the results of multiple regression are presented in the next chapter in order to test and discuss the research hypotheses.

Chapter 9

Testing the research hypotheses

9.1	Introduction.....	9-2
9.2	Testing the hypotheses relating to factors influencing the extent of performance measurement diversity usage (PMD).....	9-2
9.3	Testing the hypotheses relating to the effectiveness of performance measurement diversity usage.....	9-17
9.4	Testing the hypotheses relating to factors influencing the extent of balanced scorecard usage (BSCUSE).....	9-25
9.5	Summary.....	9-36

Chapter 9

Testing the research hypotheses

9.1 Introduction

It was pointed out in the previous chapter that structural equation modelling (SEM) will be performed to investigate the anticipated relationships between various contingent variables and the extent of performance measurement diversity usage. SEM will also be utilised to examine the relationships between the contingent variables, the extent of performance measurement diversity usage and organisational effectiveness, whereas multiple regression will be used to examine the relationships between various contingent variables and the extent of balanced scorecard usage.

The major aim of this chapter is to present and discuss the statistical results relating to the research hypotheses. This chapter covers the following sections: Section 9.2 presents and discusses the findings relating to the hypotheses tests of the relationships between the contingent variables and the extent of performance measurement diversity usage. Section 9.3 presents and discusses the findings relating to the hypotheses tests of the relationship between the contingent variables, the extent of performance measurement diversity usage, and organisational effectiveness. Section 9.4 presents and discusses the findings applicable to the hypotheses tests of the relationships between the contingent variables and the extent of balanced scorecard usage. Finally, the chapter summary is presented in section 9.5.

9.2 Testing the hypotheses relating to factors influencing the extent of performance measurement diversity usage (PMD)

The hypotheses of this section are aimed at investigating the relationships between the independent variables (COSTSTR, DIFFSTR, CENTRA, FORMAL, OPEPEU, MATPEU, REGPEU, TQM, JIT, PRODCOM, MARKCOM, and SIZESA) and the extent of performance measurement diversity usage (PMD). These hypotheses were tested using EQS 5.7 (Bentler, 1995). Due to the model complexity, the decision was made to divide the general hypothesised model into 12 sub-models to test the hypotheses (see Chapter 8, sub-section 8.4.6). The analysis procedures to test the hypotheses of this section require evaluating the model goodness-of-fit to check if the hypothesised model is similar to the

observed data. In addition, the significance of the parameter estimates was evaluated through beta coefficients, the calculated t-values for each coefficient and the coefficient of determination (see Chapter 8, sub-section 8.4.5). Finally, it should be noted that one case was identified as a multivariate outlier and was thus deleted. This is consistent with the recommendation by West et al. (1995) to drop extreme cases (i.e. outliers). Thus, the results of SEM analysis and the discussion are now presented.

H1a: *Low cost strategy has a negative impact on the extent of performance measurement diversity usage.*

The structural model analysis aimed to test H1a was estimated with one path $COSTSTR \rightarrow PMD$ (see Figure 9.1)¹. The review of the goodness-of-fit measures well exceed the recommended cut-off values (Chi-square 33.52; $P = 0.30$; GFI 0.96; AGFI 0.92; NFI 0.94; CFI 0.99; NNFI 0.99; RMSEA 0.02). The coefficient of determination R^2 of the regression path ($COSTSTR \rightarrow PMD$) is 0.25. This means that 25% of the total variance in PMD was accounted for by the COSTSTR. Reviewing the hypothesised model also revealed a beta of 0.50 (t-value = 3.185) thus indicating that the completely standardised coefficient of $COSTSTR \rightarrow PMD$ regression path is significant. This result partially supports H1a (but in the inverse direction). In other words, the extent of performance measurement diversity usage will be affected by a low cost strategy.

Figure 9.1 Hypothesised model of the relationship between cost strategy and PMD

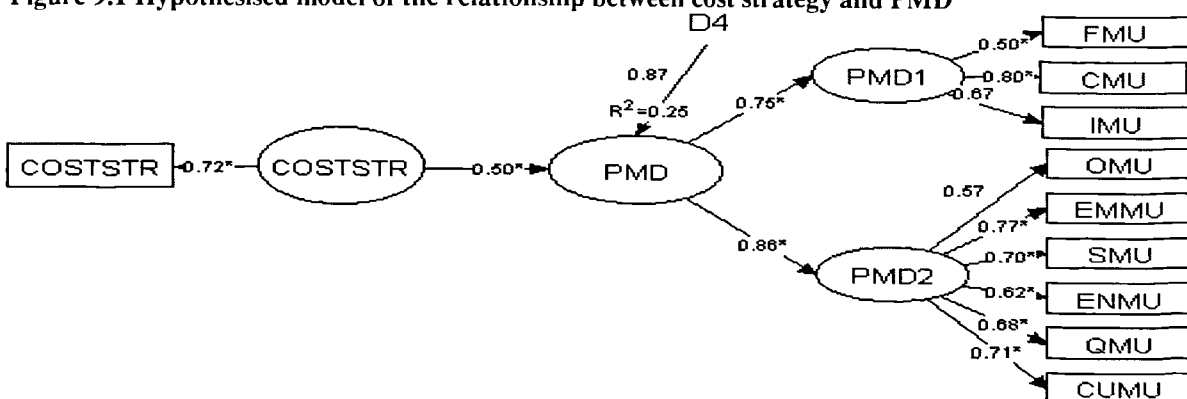

The indirect effect is one of the most important attributes of SEM, which show the effect of an independent variable on a dependent variable through one or more intervening or

¹ The figure shows the relationship between low cost strategy 'COSTSTR' (i.e. which is presented in the figure as a latent variable which consists of ellipse. While, the PMD is presented as only ellipse because it was resulted from the second-order confirmatory factor analysis (see Chapter 8, sub-section 8.2.8 for an explanation). D4 in Figure 9.1 represents the disturbance or the residual of the variable (see Chapter 6, sub-section 6.14.3 for an explanation).

mediating variables (Hoyle, 1995, p. 4). However, the results of the indirect effect confirmed the results of the direct relationship (i.e. COSTSTR→PMD), in which significant relationships were found between COSTSTR and each of FMU, CMU, IMU, OMU, EMMU, SMU, ENMU, QMU, and CUMU (i.e. which is represented as rectangles in Figure 9.1) with a standard coefficient ranging from 0.15 to 0.40 (t-values ranging from 2.756 to 3.646).

The above direct and indirect results imply that a low cost strategy has a positive impact on the extent of performance measurement diversity usage (i.e. financial and non-financial measures). The literature on performance measurement systems supports these results in which the usage of performance measurement is associated with business strategy (Govindarajan and Gupta, 1985). It has been argued that strategic choices affect the design of non-traditional results controls within the management control system. On the other hand, the above result is not expected since companies following a low cost strategy are expected to focus more on financial control. This result may, however, be justified based on Guenther and Gruening's (2002) view that the advanced performance measurement systems have to be adjusted to business strategy, and a low cost strategy also needs non-financial performance measurements. In this context, Smith (1997) indicates that the need for non-financial performance measurements is due to the recognition of customer needs, and these require the simultaneous satisfaction of lower cost, higher quality, faster response time and greater innovation. It has been also argued that many organisations monitor the efficiency and effectiveness of activities performance measures as a means of advancing competitiveness and managing cost (Drury, 1997). Therefore, non-financial performance measures relating to time, cost of activities and the quality of processes and products should complement the financial performance measurements (Cauvin and Bescos, 2002).

H1b: *Differentiation strategy has a positive impact on the extent of performance measurement diversity usage.*

The structural model analysis that aimed to test H1b was estimated with one path DIFFSTR→PMD (see Figure 9.2). The review of goodness-of-fit measures exceeded the recommended cut-off values (Chi-square 37.87; P = 0.15; GFI 0.95; AGFI 0.92; NFI 0.93; CFI 0.98; NNFI 0.97; RMSEA 0.04). The coefficient of determination R² of the regression path (DIFFSTR→PMD) is 0.01. This means that 1% of the total variance in PMD was accounted for by the DIFFSTR. Reviewing the hypothesised model also revealed a beta of

0.08 (t-value = 0.759) resulting in the completely standardised coefficient of DIFFSTR→PMD regression path being not significant. Thus, H1b is rejected at the 0.05 significance level since the calculated t-value is less than the critical t-value of 1.645.

Figure 9.2 Hypothesised model of the relationship between differentiation strategy and PMD

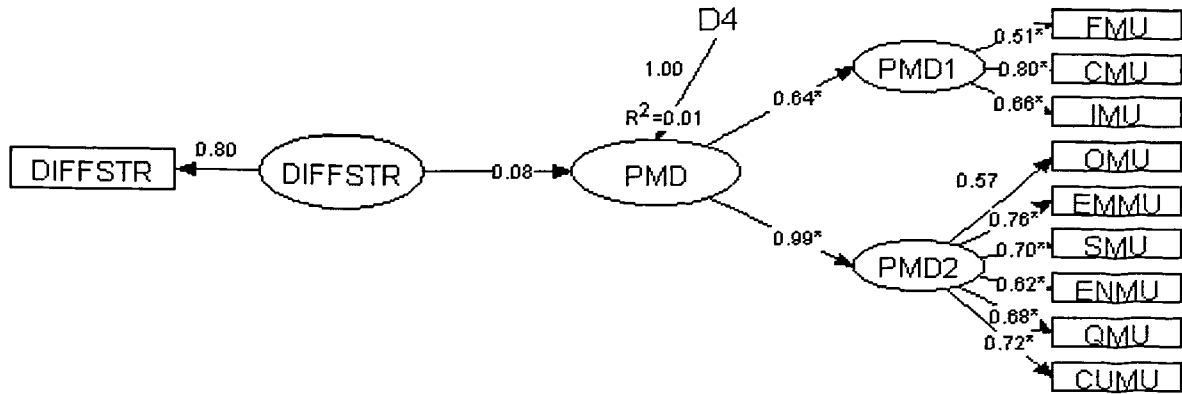

With regard to the indirect effect, the results of SEM confirmed the direct relationship (i.e. DIFFSTR→PMD), in which no significant relationships were found between DIFFSTR and each of FMU, CMU, IMU, OMU, EMMU, SMU, ENMU, QMU, and CUMU with a standard coefficient ranging from 0.03 to 0.11 (t-values ranging from 0.753 to 0.761).

The above direct and indirect results do not support the direct relationship between differentiation strategy and the extent of performance measurement diversity usage. This result was not expected since it may contradict with the literature, which places an emphasis on the relationship between business strategy and the choice of performance measures (e.g. Drucker, 1990; Ittner et al., 1997). Interpretations of this contradictory result is not easy, taking into consideration that previous empirical studies (e.g. Brignall, 1997) have confirmed the positive relationship between differentiation strategy and the greater use of non-financial performance measurements. In contrast, other empirical studies (e.g. Morissette, 1998; Van der Stede et al., 2001) have found no relationship between differentiation strategy and the increased use of non-financial performance measurements. However, the above result may be justified based on Anthony and Govindarajan’s (2001) argument that not all the non-financial performance measurements are applicable to all business strategies. Only those non-financial measurements that reflect key success factors or key performance indicators that will determine the successful implementation of business strategies may be relevant. In general, the results emerged from testing hypotheses H1a and H1b have shown unexpected findings,

thus, it can be noted that this result is consistent with Langfield-Smith's (1997) argument that the effect of business strategy on control system design is controversial and unclear.

Research question 1: *Does the structural dimension of centralisation have a direct impact on the extent of performance measurement diversity usage?*

The structural model analysis was estimated with one path CENTRA→PMD (see Figure 9.3) to test research question 1. The review of goodness-of-fit measures exceeded the recommended cut-off values (Chi-square 34.22; P = 0.23; GFI 0.96; AGFI 0.93; NFI 0.93; CFI 0.99; NNFI 0.98; RMSEA 0.03). The coefficient of determination R^2 of the regression path (CENTRA→PMD) is 0.01. This means that 1% of the total variance in PMD was accounted for by the CENTRA. Reviewing the hypothesised model CENTRA→PMD also revealed a beta of -0.12 (t-value = -1.072), thus indicating a negative direct effect but non-significant between centralisation and PMD. Thus, the findings relating to research question 1, which predicts a direct relationship between the centralisation dimension of structure and the extent of performance measurement diversity usage was not supported at the 0.05 significance level, since the calculated t-value is less than the critical t-value = 1.960.

With regard to the indirect effect, the results of SEM confirmed the results of the negative direct relationship (i.e. CENTRA→PMD), in which no significant relationships were found between CENTRA and each of FMU, CMU, IMU, OMU, EMMU, SMU, ENMU, QMU, and CUMU (with a standard coefficient ranging from -0.03 to -0.08; t-values ranging from -0.909 to -0.951).

Figure 9.3 Hypothesised model of the relationship between centralisation and PMD

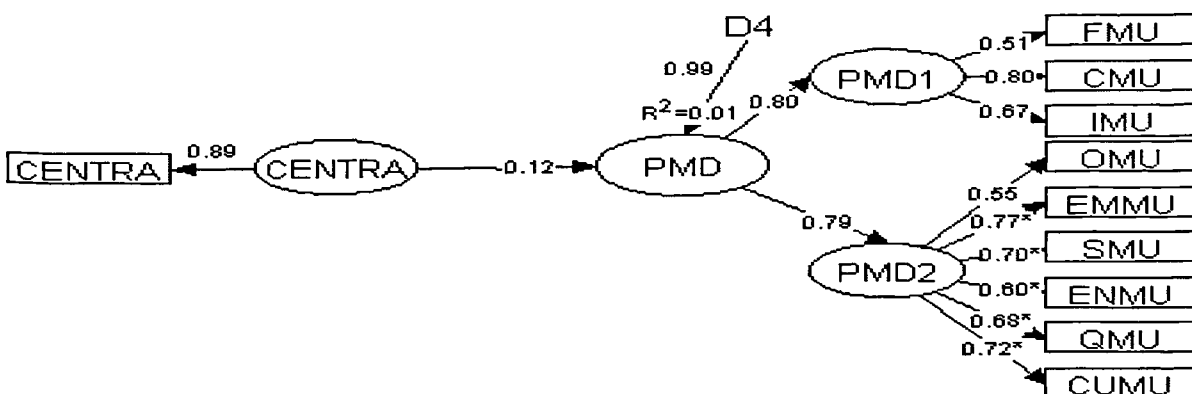

The result of the structural equation model therefore does not support the direct and indirect relationship between centralisation and the extent of performance measurement diversity

usage. Centralisation refers to the hierarchical level that has the authority to make a decision. When decision making is kept at the top management level the organisation is centralised but when decisions are delegated to other levels the organisation is decentralised (Daft, 1992). The negative and non-significant result that emerged may be justified based on the fact that today many companies concentrate on team-working and employee involvement and this may lead to new and flexible approaches to the design of performance measurement system (Johnson and Kaplan, 1987). In addition, Chenhall and Morris (1986) have argued that in centralised as opposed to decentralised organisations, senior managers are more familiar with the overall operations of their organisations, and their decisions are based on formal management control, while the usage of non-financial performance measurements is associated mainly with the operational levels in the organisational hierarchy. Thus, a change in organisation design, with greater use of team-based structures would result in a greater reliance on non-financial information (Baines and Langfield-Smith, 2003).

Research question 2: *Does the structural dimension of formalisation have a direct impact on the extent of performance measurement diversity usage?*

The structural model analysis was estimated with one path FORMAL→PMD (see Figure 9.4) to test research question 2. The review of goodness-of-fit measures well exceed the recommended cut-off values (Chi-square 26.91; P = 0.62; GFI 0.96; AGFI 0.93; NFI 0.95; CFI 1.00; NNFI 1.00; RMSEA 0.00). The coefficient of determination R^2 of the regression path (FORMAL→PMD) is 0.44. This means that 44% of the total variance in PMD was accounted for by the FORMAL. Reviewing the hypothesised model FORMAL→PMD also reveal a beta = 0.66 (t-value = 3.548), thus, indicating a significant direct effect of formalisation on PMD. Thus, the findings relating to research question 2, which predicts a direct relationship between the formalisation dimension of structure and the extent of performance measurement diversity usage was supported at 0.05 significance level, since the calculated t-value is more than the critical t-value = 1.960. The results of SEM indicate indirect relationships between formalisation and the extent of performance measurement diversity usage dimensions. This result confirms the findings that emerged from the direct relationship (i.e. CENTRA→PMD). However, the indirect results show significant relationships between CENTRA and each of FMU, CMU, IMU, OMU, EMMU, SMU, ENMU, QMU, and CUMU with a standard coefficient ranging from 0.17 to 0.60 (t-values ranging from 3.718 to 5.012).

Figure 9.4 Hypothesised model of the relationship between formalisation and PMD

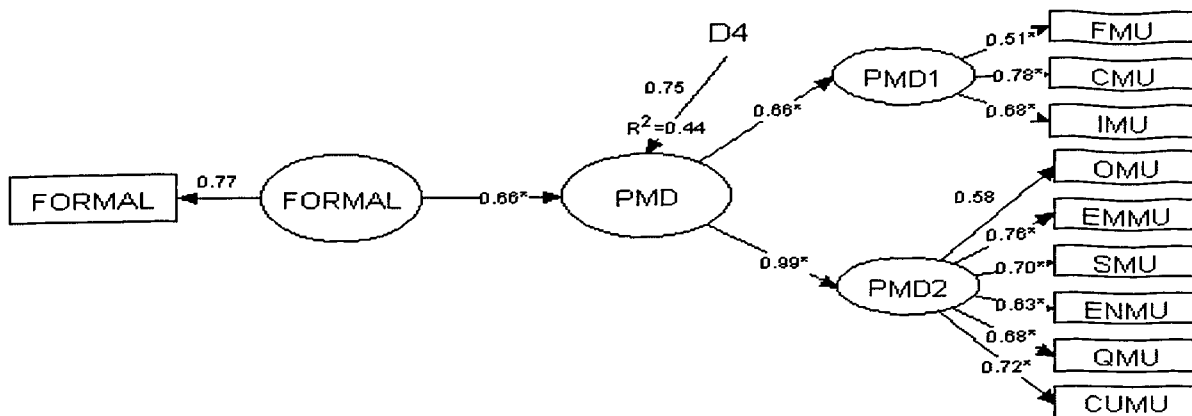

The above direct and indirect results imply that formalisation has a positive impact on the extent of performance measurement diversity usage (i.e. financial and non-financial measures). Formalisation refers to the amount of written documentation in the organisation including procedures, job descriptions, regulations and policies (Daft, 1992). The result indicates that structured and formalised organisations should be complemented with non-financial performance measurements in order to deal with the effects of formalisation. This result may be justified based on the idea that using performance measurements in terms of financial and non-financial are expected to reduce the negative effect of formalisation by increasing managers' flexibility to do what they deem appropriate to meet the specified goals, and in turn, increase their responsibilities and organisational commitment (Agarwal, 1999, p. 363).

H2: *Perceived environmental uncertainty has a positive impact on the extent of performance measurement diversity usage.*

To recall from the discussion in sub-section 8.2.3, PEU was measured in this research by three dimensions, OPEPEU, MATPEU, and REGPEU. Therefore, three structural models of PEU were estimated. The first structural model analysis was estimated with one path OPEPEU→PMD (see Figure 9.5). The review of goodness-of-fit measures well exceed the recommended cut-off values (Chi-square 39.18; P = 0.17; GFI 0.95; AGFI 0.92; NFI 0.92; CFI 0.98; NNFI 0.98; RMSEA 0.03). The coefficient of determination R^2 of the regression path (OPEPEU→PMD) is 0.01. This means that 1% of the total variance in PMD was accounted for by the OPEPEU. Reviewing the hypothesised model OPEPEU→PMD also reveal a beta of -0.10 (t-value = -0.993), thus, indicating a negative but non-significant direct effect between OPEPEU and PMD.

Figure 9.5 Hypothesised model of the relationship between operational-peu and PMD

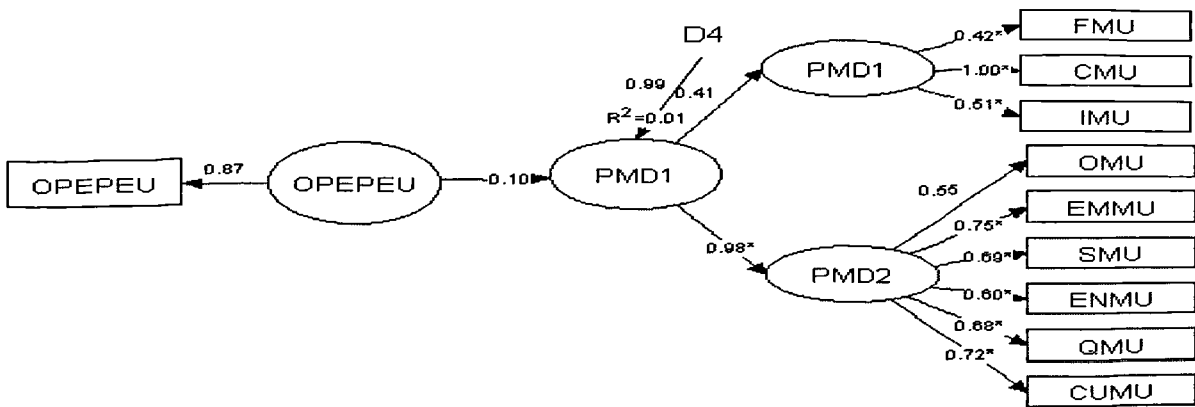

The indirect results show negative non-significant relationships between OPEPEU and each of FMU, CMU, IMU, OMU, EMMU, SMU, ENMU, QMU, and CUMU with a standard coefficient ranging from -0.01 to -0.09 (t-values ranging from -0.979 to -0.995). This result confirms the findings emerged from the direct relationship (i.e. OPEPEU→PMD).

The second structural model was estimated with one path MATPEU→PMD (see Figure 9.6). The review of the goodness-of-fit measures well exceed the recommended cut-off values (Chi-square 39.08; P = 0.15; GFI 0.95; AGFI 0.91; NFI 0.92; CFI 0.98; NNFI 0.97; RMSEA 0.04). The coefficient of determination R^2 of the regression path (MATPEU→PMD) is 0.03. This means that 3% of the total variance in PMD was accounted for by the MATPEU. Reviewing the hypothesised model MATPEU→PMD also revealed a beta of -0.18 (t-value = -1.211), thus indicating a negative but non-significant direct effect between MATPEU and PMD.

Table 9.6 Hypothesised model of the relationship between raw material-peu and PMD

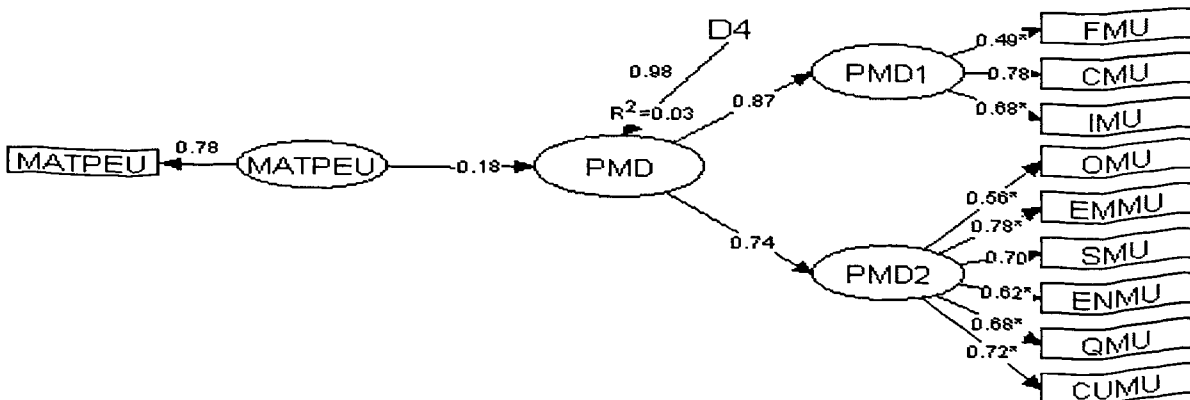

The indirect results also show negative non-significant relationships between OPEPEU and each of FMU, CMU, IMU, OMU, EMMU, SMU, ENMU, QMU, and CUMU with a standard coefficient ranging from -0.06 to -0.14 (t-values ranging from -1.203 to -1.344). This result confirms the findings emerged from the direct relationship (i.e. MATPEU→PMD).

The third and final structural model of PEU was estimated with one path REGPEU→PMD (see Figure 9.7). The review of the goodness-of-fit measures well exceed the recommended cut-off values (Chi-square 34.46; P = 0.35; GFI 0.95; AGFI 0.92; NFI 0.93; CFI 0.99; NNFI 0.99; RMSEA 0.02). The coefficient of determination R^2 of the regression path (REGPEU→PMD) is 0.05. This means that 5% of the total variance in PMD was accounted for by the REGPEU. Reviewing the hypothesised model REGPEU→PMD also revealed a beta of 0.21 (t-value = 2.167), thus indicating a significant direct effect of REGPEU on PMD. The indirect results also show significant relationships between REGPEU and each of FMU, CMU, IMU, OMU, EMMU, SMU, ENMU, QMU, and CUMU with a standard coefficient ranging from 0.05 to 0.19 (t-values ranging from 1.998 to 2.167). This result confirms the findings emerged from the direct relationship (i.e. REGPEU→PMD).

Figure 9.7 Hypothesised model of the relationship between regulatory-peu and PMD

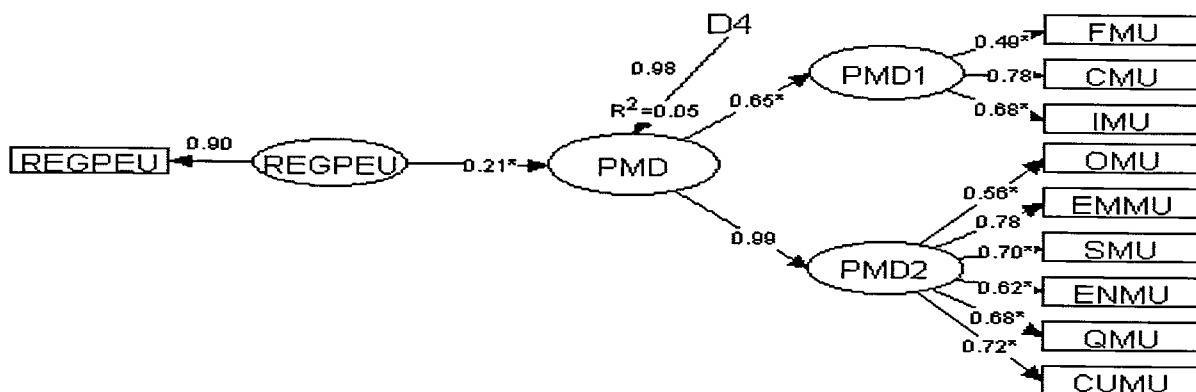

With respect to the effect of perceived environmental uncertainty dimensions of OPEPEU, MATPEU, and REGPEU on the extent of performance measurement diversity usage (PMD), it was hypothesised that PEU will have a positive impact on PMD. Surprisingly, the results showed inverse and non-significant results for OPEPEU and MATPEU dimensions, while REGPEU was found to have a positive and significant impact on the extent of PMD usage. Thus, H2 was partially supported for the effect of REGPEU on PMD.

Interpreting the contradictory results is somewhat difficult, taking into consideration that earlier studies have confirmed the positive relationship between perceived environmental uncertainty and the use of financial and non-financial performance measurements (e.g. Govindarajan, 1984; Gul and Chia, 1994). However, a recent empirical study by Verbeeten (2004) revealed that perceived environmental uncertainty has no impact on the usage of financial and non-financial performance measurements.

The results of the two dimensions of PEU (OPEPEU and MATPEU) may be justified based on the idea that organisations facing high unpredictability (i.e. for both operational oriented and raw material) in their environment may rely on formal systems of control. In contrast, organisations facing high unpredictability in governmental regulations may tend to use financial and non-financial performance measurement to enhance their awareness and responsiveness to environmental uncertainties. This result is consistent with the argument provided by Ittner et al. (1997), in which they indicated that non-financial performance measurements are extensively used in regulated industries, because government intervention in regulated industries may lead companies to place greater emphasis on non-financial performance measurements. Thus, it can be noted that regulated companies tend to rely more on non-financial performance measures than non-regulated companies (Said et al., 2003).

H3: *The intensity of competition has a positive impact on the extent of performance measurement diversity usage.*

To recall from our discussion in sub-section 8.2.4, intensity of competition was measured in this research by two dimensions, MARKCOM and PRODCOM. Therefore, two structural models were estimated. First, the structural model analysis was estimated with one path MARKCOM→PMD (see Figure 9.8). The review of goodness-of-fit measures well exceed the recommended cut-off values (Chi-square 28.17; P = 0.50; GFI 0.96; AGFI 0.93; NFI 0.94; CFI 1.00; NNFI 1.00; RMSEA 0.00). The coefficient of determination R^2 of the regression path MARKCOM→PMD is 0.09. This means that 9% of the total variance in PMD is accounted for by the MARKCOM. Reviewing the hypothesised model also revealed that beta = 0.30, t-value = 2.392, thus, indicating a direct significant effect of MARKCOM on PMD. The indirect results show a significant relationships between MARKCOM and each of OMU, EMMU, SMU, ENMU, QMU, and CUMU with a standard coefficient ranging from 0.24 to 0.38 (t-values ranging from 2.392 to 2.470).

Figure 9.8 Hypothesised model of the relationship between market competition and PMD

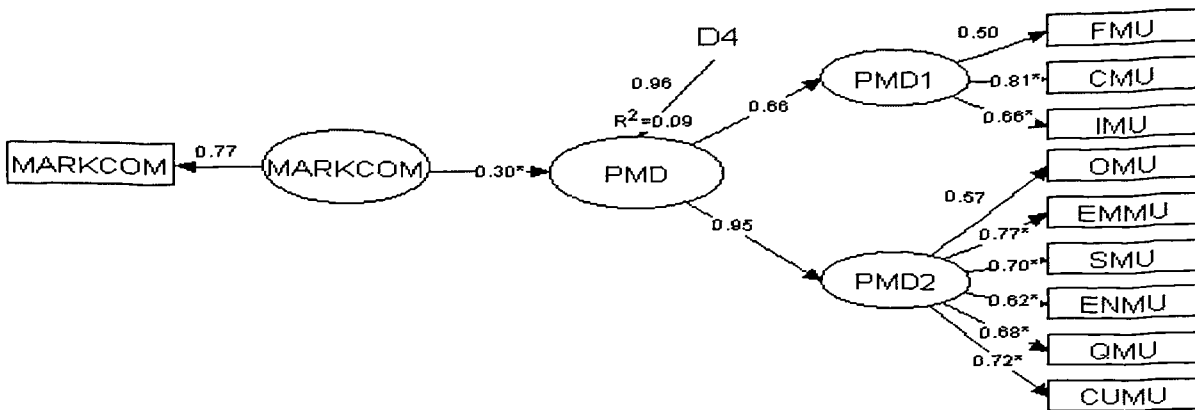

The second structural model was estimated with one path PRODCOM→PMD (see Figure 9.9). The review of goodness-of-fit measures well exceed the recommended cut-off values (Chi-square 37.81; P = 0.15; GFI 0.95; AGFI 0.91; NFI 0.93; CFI 0.98; NNFI 0.97; RMSEA 0.04). The coefficient of determination R^2 of the regression path (PRODCOM→PMD) is 0.05. This means that 5% of the total variance in PMD is accounted for by the PRODCOM. Reviewing the hypothesised model PRODCOM→PMD also revealed a beta of 0.23 (t-value = 2.184), thus indicating a direct significant effect of PRODCOM on PMD. The indirect results also show a significant relationships between PRODCOM and each of FMU, CMU, IMU, OMU, EMMU, SMU, ENMU, QMU, and CUMU with a standard coefficient ranging from 0.09 to 0.18 (t-values ranging from 2.141 to 2.297).

Figure 9.9 Hypothesised model of the relationship between product competition and PMD

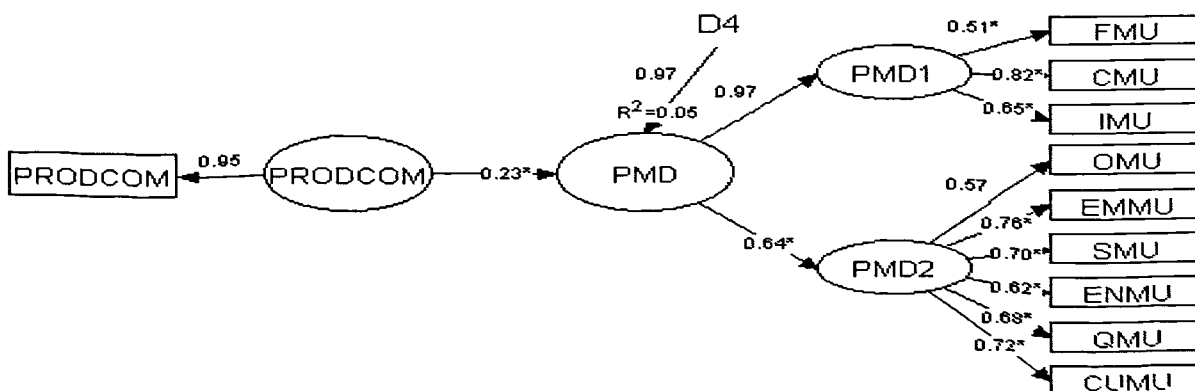

With respect to the effect of intensity of competition dimensions of MARKCOM and PRODCOM on the extent of performance measurement diversity usage (PMD), it was hypothesised that intensity of competition will have a positive impact on PMD. The results showed a positive and significant impact of MARKCOM and PRODCOM dimensions on the

extent of PMD usage. Thus, H3 was accepted at the 0.05 significance level since the calculated t-values are more than the critical t-value = 1.645. This indicates that intensity of competition has a positive impact on the extent of performance measurement diversity usage.

The literature on performance measurement systems supports the above results in which the extent of usage of financial and non-financial performance measurements is necessary for coping with the intensity of market competition. Empirically, Hoque et al. (2001) have found a positive impact of market competition on the usage of financial and non-financial performance measures. It has been argued that multiple performance measures (i.e. financial and non-financial) are crucial not only to track the financial performance of organisations but that non-financial performance measures which track customer satisfaction, innovation together with quality production are essential to achieve competitive advantage in the highly intense markets (Ittner and Larcker, 1998a). Moreover, Bititci et al. (2002) argued that management requires accurate performance information on its customers and market, competitive position, financial performance, customer service performance, operational performance and suppliers' performance. Thus, the usage of both financial and non-financial performance measurements is a necessary step for manufacturing companies to cope with the intensity of market competition (Bhimani, 1994).

H4: *Organisation size has a positive impact on the extent of performance measurement diversity usage.*

The structural model analysis aimed to test H4 was estimated with one path SIZESA→PMD (see Figure 9.10). The review of goodness-of-fit measures well exceed the recommended cut-off values (Chi-square 38.60; P = 0.13; GFI 0.95; AGFI 0.91; NFI 0.93; CFI 0.98; NNFI 0.97; RMSEA 0.04). The coefficient of determination R^2 of the regression path (SIZESA→PMD) is 0.17. This means that 17% of the total variance in PMD is accounted for by the SIZESA. Reviewing the hypothesised model also revealed that beta = 0.41 (t-value = 3.903) of the completely standardised coefficient of SIZESA→PMD regression path is significant. Thus, this result supported H4 at the 0.05 significance level since the calculated t-values are more than the critical t-value of 1.645. With regard to the indirect effect, the results of SEM confirmed the results of the direct relationship (i.e. SIZESA→PMD), in which significant relationships were found between SIZESA and each of FMU, CMU, IMU,

OMU, EMMU, SMU, ENMU, QMU, and CUMU with a standard coefficient ranging from 0.14 to 0.32 (t-values ranging from 3.207 to 3.754).

Figure 9.10 Hypothesised model of the relationship between size and PMD

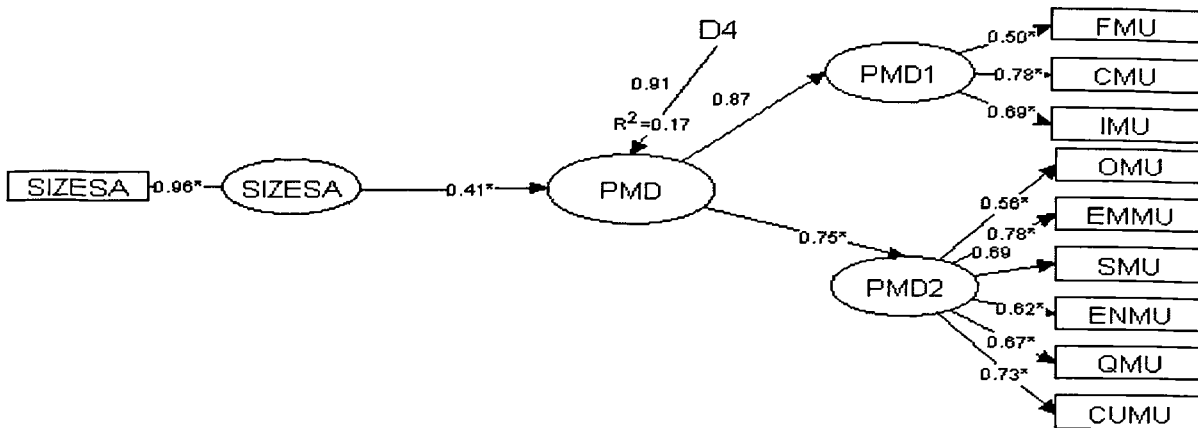

The above result implies that the size of organisations has a positive impact on the usage of performance measurement diversity. In common with this study, previous empirical studies have found that organisation size was a significant variable. For instance, Verbeeten (2004) reported that organisation size is positively associated with the use of non-financial performance measurements. It has been argued in the literature that as the size of an organisation increases, the management control and information systems tend to be more sophisticated. In other words, the usage of financial and non-financial performance measurements in large organisations is relatively high due to the greater access to several resources to experiment with more sophisticated systems (Drury, 2002).

H5: *The extent of the use of total quality management has a positive impact on the extent of performance measurement diversity usage.*

The structural model analysis aimed to test H5 was estimated with one path TQM→PMD (see Figure 9.11). The review of the goodness-of-fit measures well exceed the recommended cut-off values (Chi-square 30.40; P = 0.39; GFI 0.96; AGFI 0.92; NFI 0.94; CFI 0.99; NNFI 0.99; RMSEA 0.01). The coefficient of determination R^2 of the regression path (TQM→PMD) is 0.52. This means that 52% of the total variance in PMD was accounted for by the TQM. Reviewing the hypothesised model also revealed that beta = 0.72 (t-value = 4.926) of the completely standardised coefficient of TQM→PMD so the regression path is significant. Thus, this result supported H5 at 0.05 significance level since the calculated t-values are more than the critical t-value = 1.645. With regard to the indirect effect, the results

of SEM confirmed the results of the direct relationship (i.e. TQM→PMD), in which significant relationships were found between TQM and each of FMU, CMU, IMU, OMU, EMMU, SMU, ENMU, QMU, and CUMU with a standard coefficient ranging from 0.22 to 0.58 (t-values ranging from 3.819 to 5.079).

Figure 9.11 Hypothesised model of the relationship between total quality management and PMD

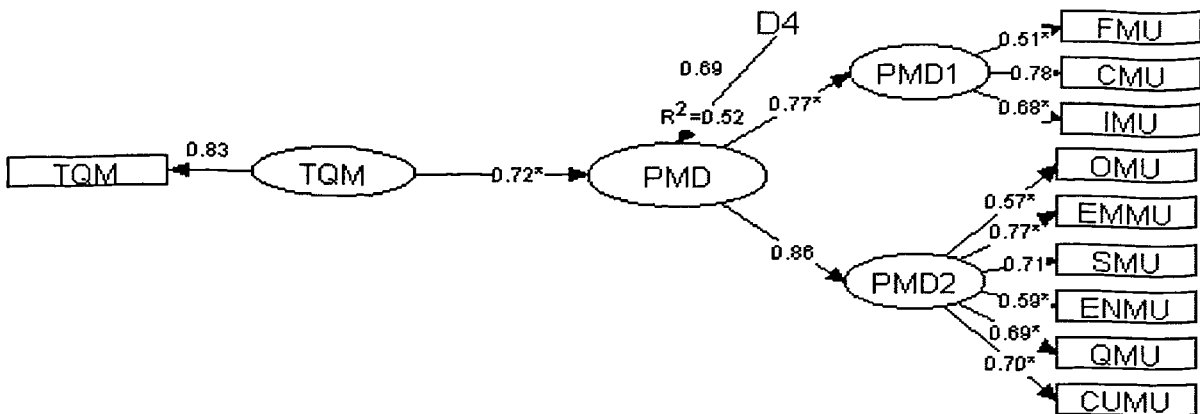

The above result indicates that the use of total quality management has a positive impact on the extent of performance measurement diversity usage. It has been argued that today's global competitive markets require improved quality of products with a focus on the customers. These conditions require a manufacturing enterprise to concentrate more on continuous improvements in terms of their activities. An important issue relating to improvements is total quality management which is considered to be an important component of management practices to simplify products design, interaction with suppliers and the continuous upkeep of production equipment (Johnson and Kaplan, 1987). Total quality management is a prominent issue of fundamental change that many companies are introducing. It has been argued that improvement initiatives such as TQM have influenced the inclusion of more non-financial performance measures within performance measurement systems. In this context, Bhimani (1994) provided evidence from UK manufacturing companies that the adoption of TQM was matched with the usage of non-financial performance measures. In the UK, 20% of the surveyed companies believed that their TQM programs had a significant impact on their performance (McAdam and Bannister, 2001). In the empirical work by Chenhall (1997) and Sim and Killough (1998) the application of total quality management was strongly associated with the use of non-financial performance measures. Based on the above arguments and findings, it can be concluded that the extent of usage of TQM plays a major role in using more non-financial performance measurements.

H6: *The extent of the use of just in time manufacturing approaches has a positive impact on the extent of performance measurement diversity usage.*

The structural model analysis aimed to test H6 was estimated with one path JIT→PMD (see Figure 9.12). The review of goodness-of-fit measures well exceed the recommended cut-off values (Chi-square 35.57; P = 0.22; GFI 0.96; AGFI 0.92; NFI 0.93; CFI 0.98; NNFI 0.98; RMSEA 0.03). The coefficient of determination R^2 of the regression path (JIT→PMD) is 0.15. This means that 15% of the total variance in PMD was accounted for by the JIT. Reviewing the hypothesised model also revealed a beta of 0.38 (t-value = 2.962) of the completely standardised coefficient of the JIT→PMD so the regression path is significant. Thus, this result supports H6 at the 0.05 significance level since the calculated t-values are more than the critical t-value = 1.645. This indicates that the use of just in time manufacturing approaches has a positive impact on the extent of performance measurement diversity usage. With regard to the indirect effect, the results of SEM confirmed the results of the direct relationship, in which significant relationships were found between JIT and each of FMU, CMU, IMU, OMU, EMMU, SMU, ENMU, QMU, and CUMU with a standard coefficient ranging from 0.13 to 0.30 (t-values ranging from 2.509 to 2.962).

Figure 9.12 Hypothesised model of the relationship between just in time and PMD

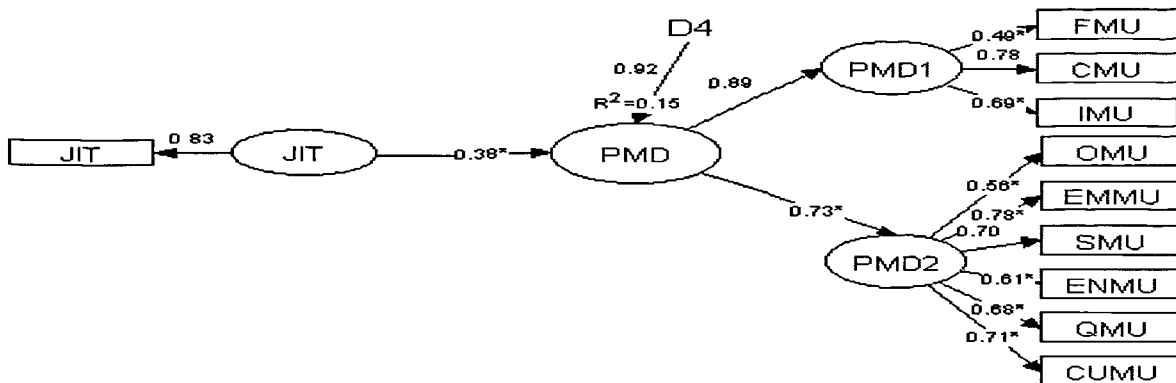

The above results indicate that the use of just in time manufacturing approaches has a positive impact on the extent of performance measurement diversity usage. Just in time manufacturing approaches involve a manufacturing philosophy emphasising excellence through continuous improvements in productivity and elimination of waste (Fullerton and McWatters, 2002). It has been argued in the literature that management accounting systems should be designed contingent on characteristics of production systems. In addition, the adoption of just in time manufacturing approaches should be matched with the usage of non-

financial performance measures in UK manufacturing companies. In the empirical work by Upton (1998) and Fullerton and McWatters (2002), the application of just in time was strongly associated with the use of non-financial performance measures. Thus, it can be concluded that the extent of usage of just in time manufacturing approaches plays a major role in using more non-financial performance measures.

9.3 Testing the hypotheses relating to the effectiveness of performance measurement diversity usage

It was pointed out in Chapter 4, section 4.3 that several approaches relating to fit have been presented in the literature. Effectiveness under the selection and interaction approaches was investigated through moderation and mediation effects. However, the systems approach asserts the need to utilise the multivariate analysis to examine the pattern of internal consistency among the contingent variables, management control system and effectiveness. Therefore, structural equation modelling (SEM) was utilised to test for the internal consistency in terms of the 'coalignment' between the contingent variables and the extent of performance measurement diversity usage on organisational effectiveness. Thus, the analysis procedures to test for coalignment requires evaluating the model goodness-of-fit and the significance of parameter estimates as described in Chapter 8. The statistical significance of the loading of first order factors (i.e. the contingent variables and the extent of performance measurement diversity usage) on the coalignment and, thus the magnitude and significance of path coefficient between coalignment and organisational effectiveness, show the effect of this coalignment 'fit'. The hypotheses of this section are aimed at investigating the effect of coalignment 'fit' between the independent variables (COSTSTR, DIFFSTR, CENTRA, FORMAL, OPEPEU, MATPEU, REGPEU, TQM, JIT, PRODCOM, MARKCOM, and SIZESA) and the extent of performance measurement diversity usage (PMD) on organisational effectiveness. It should be noted that organisational effectiveness was measured in two different ways. First, organisational effectiveness was measured by a multiplicity of financial and non-financial performance measures 'organisational performance' (EFFECT). Second, organisational effectiveness was measured by the level of satisfaction (SATISFAC) (see Sub-section 8.2.10 in Chapter 8 for an explanation of how both EFFECT and SATISFAC have been calculated). Therefore, two hypotheses were formulated to test the coalignment effect of the independent variables and the dependent variable on organisational effectiveness. Finally, both low cost and differentiation strategies

are incorporated in two separate structural models². The rationale behind using two models is due to the fact that businesses are compelled to compete by differentiating their products on the basis of either product characteristics or low price (Porter, 1980; 1985). According to Chenhall and Langfield-Smith (1998b, p. 244), Porter contended that a firm should choose between competing on either product differentiation or low cost.

H1a: *The fit or coalignment among the extent of performance measurement diversity usage, business strategy, organisational structure, perceived environmental uncertainty, intensity of competition, size, total quality management and just in time manufacturing approaches has a positive impact on organisational performance.*

The first structural model aims to investigate the impact of coalignment or fit between the contingent variables and the extent of performance measurement diversity usage on organisational performance. Figure 9.13 represents two coalignment models for PMD³ (i.e. low cost strategy model 1 and differentiation strategy model 2).

Figure 9.13 Coalignment model of contingent variables and PMD on organisational performance

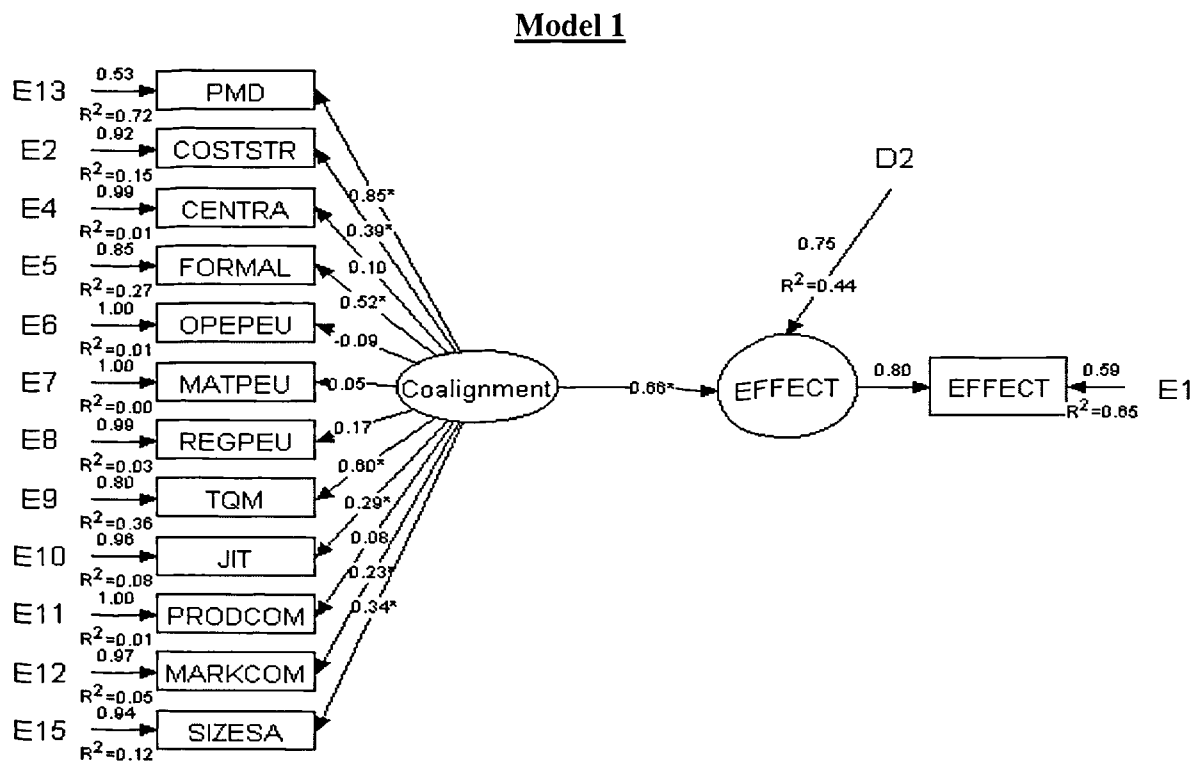

² Evaluating business strategy with separate dimensions was used in the study by Chenhall and Langfield-Smith (1998b).

³ Es in Figure 9.13 represent the measurement error for each variable, while D2 in Figure 9.13 represents the disturbance or the residual of the variable (see Chapter 6, sub-section 6.14.3 for an explanation).

Model 2

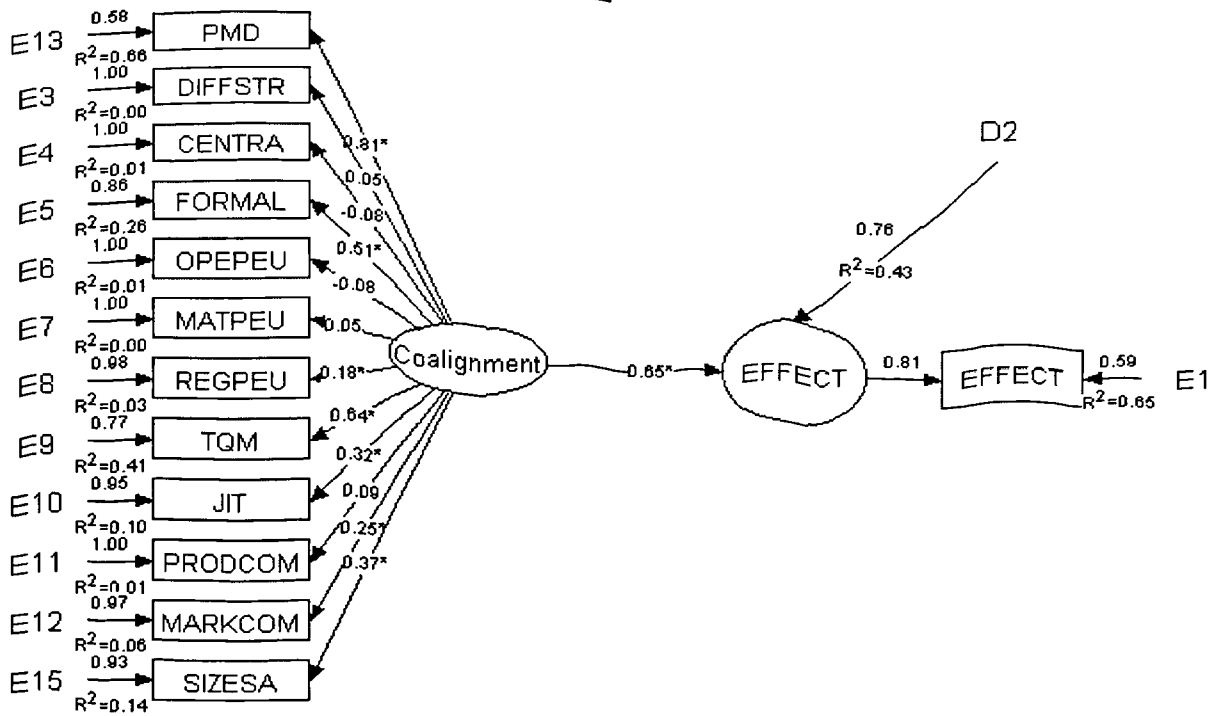

The structural model analysis aimed to test H1a was estimated with the model's fit (see Figure 9.13)⁴. The review of goodness-of-fit measures of model 1 well exceeded the recommended cut-off values (Chi-square 37.37; $P = 0.97$; GFI 0.96; AGFI 0.94; NFI 0.91; CFI 1.00; NNFI 1.00; RMSEA 0.00). The loadings of the contingent variables on the coalignment, as shown in model 1, indicate that PMD, COSTSTR, FORMAL, TQM, JIT, MARKCOM and SIZESA have significant loadings (*) with path coefficients of 0.85, 0.39, 0.52, 0.60, 0.29, 0.23 and 0.34 respectively (t -values = 11.180, 4.604, 6.403, 7.673, 3.370, 2.732 and 4.094 respectively). Thus, it can be concluded that PMD, COSTSTR, FORMAL, TQM, JIT, MARKCOM and SIZESA contribute to the coalignment in model 1. Reviewing the hypothesised model also revealed a significant path coefficient between coalignment and organisational performance ($\beta = 0.66$, t -value = 6.676 $P < 0.05$), thus confirming the positive impact of coalignment on organisational performance (EFFECT). The coefficient of determination R^2 of the regression path (coalignment \rightarrow EFFECT) is 0.44. This means that the coalignment 'fit' between PMD, COSTSTR, FORMAL, TQM, JIT, MARKCOM and SIZESA explains 44% of the variance in organisational performance.

⁴ The explanation of considering PMD as an independent variable in Figure 9.13 is due to utilising the systems approach of fit. This approach is a pattern of covariation or internal consistency among a set of underlying theoretically related variables (Venkatraman, 1989, p. 435). Thus, the coalignment effect of all the contingent variables with the PMD represented in the above model will affect organisational performance, and this coalignment can therefore be directly assessed.

The review of goodness-of-fit measures of model 2 well exceed the recommended cut-off values (Chi-square 40.45; $P = 0.91$; GFI 0.96; AGFI 0.94; NFI 0.90; CFI 1.00; NNFI 1.00; RMSEA 0.00). The loadings of the contingent variables on the coalignment, as shown in model 2, indicated that PMD, FORMAL, REGPEU, TQM, JIT, MARKCOM and SIZESA have significant loading with path coefficients of 0.81, 0.51, 0.18, 0.64, 0.32, 0.25 and 0.37 respectively (t-values = 11.990, 6.154, 2.065, 8.070, 3.664, 2.841 and 4.325 respectively). Thus, it can be concluded that PMD, FORMAL, REGPEU, TQM, JIT, MARKCOM and SIZESA contribute to the coalignment in model 2. Reviewing the hypothesised model also revealed a significant path coefficient between coalignment and organisational performance (beta = 0.65, t-value = 6.425 $P < 0.05$), thus, confirming the positive impact of coalignment on organisational performance (EFFECT). The coefficient of determination R^2 of the regression path (coalignment→EFFECT) is 0.43. This means that the coalignment 'fit' between PMD, FORMAL, REGPEU, TQM, JIT, MARKCOM and SIZESA explains 43% of the variance in organisational performance. Thus, it can be concluded that H1a was partially accepted at 0.05 significance level.

In response to the above results, it should be noted that the fit between the extent of performance measurement diversity usage, cost strategy, formalisation, total quality management, just in time manufacturing approaches, market competition and size (model 1) and between the extent of performance measurement diversity usage, formalisation, regulatory-PEU, total quality management, just in time manufacturing approaches, market competition and size (model 2) results in higher organisational performance.

Thus, in model 1, the extent of performance measurement diversity usage appears to contribute to organisational performance in large organisations following a low-cost strategy with a formalised structure, facing market competition and using both total quality management and just in time manufacturing approaches. In model 2, differentiation strategy does not contribute to organisational performance, thus, the extent of performance measurement diversity usage appears to contribute to organisational performance in large organisations with a formalised structure, facing uncertainty in both regulations and market competition and using both total quality management and just in time manufacturing approaches.

H1b: *The fit or coalignment among the extent of performance measurement diversity usage, business strategy, organisational structure, perceived environmental uncertainty, intensity of competition, size, total quality management and just in time manufacturing approaches has a positive impact on performance measurement system satisfaction.*

The second structural model aims to investigate the impact of coalignment or fit between the contingent variables and the extent of performance measurement diversity usage on the level of satisfaction of performance measurement system. Figure 9.14 represents two coalignment models for PMD (i.e. low cost strategy model 1 and differentiation strategy model 2).

Figure 9.14 Coalignment model of contingent variables and PMD on satisfaction

Model 1

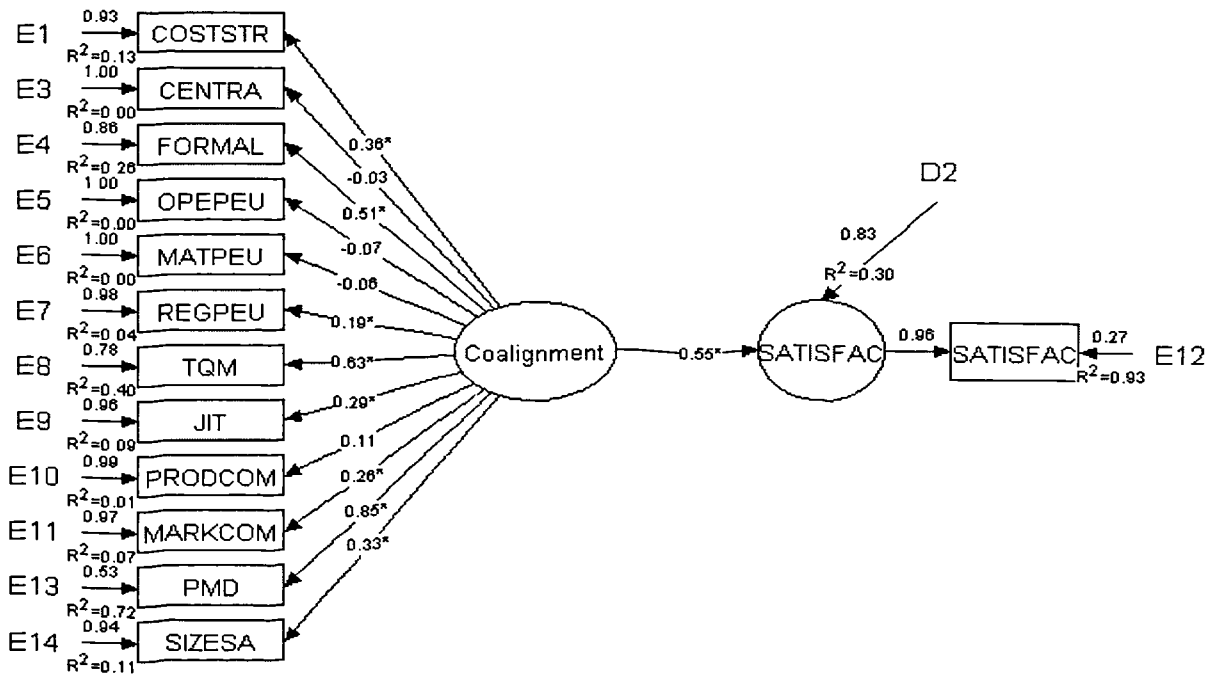

Model 2

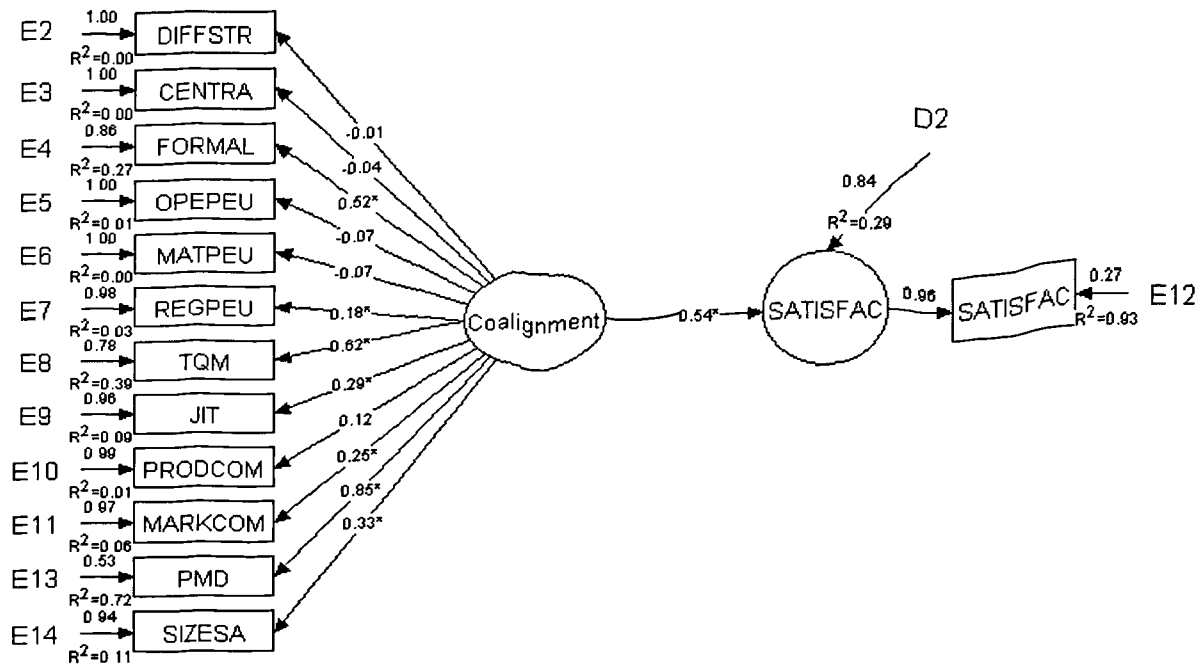

The structural model analysis that aims to test H1b is estimated based on the fit of the two models (see Figure 9.14). The review of goodness-of-fit measures of model 1 well exceeds the recommended cut-off values (Chi-square 59.86; $P = 0.44$; GFI 0.94; AGFI 0.91; NFI 0.91; CFI 0.99; NNFI 0.99; RMSEA 0.01). The loadings of the contingent variables on the coalignment, as shown in model 1, indicate that COSTSTR, FORMAL, REGPEU, TQM, JIT, MARKCOM, PMD and SIZESA have significant loadings with path coefficients of 0.36, 0.51, 0.19, 0.63, 0.29, 0.26, 0.85 and 0.33 respectively (t -values = 4.234, 6.179, 2.187, 7.921, 3.378, 3.001, 11.081 and 3.867 respectively). Thus, it can be concluded that COSTSTR, FORMAL, TQM, JIT, MARKCOM, PMD and SIZESA contribute to the coalignment in model 1. Reviewing the hypothesised model also revealed a significant path coefficient between coalignment and level of satisfaction ($\beta = 0.55$, t -value = 6.540 $P < 0.05$), thus, confirming the positive impact of coalignment on level of satisfaction (SATISFAC). The coefficient of determination R^2 of the regression path (coalignment \rightarrow SATISFAC) is 0.30. This means that the coalignment 'fit' between COSTSTR, FORMAL, TQM, JIT, MARKCOM, PMD and SIZESA explains 30% of the variance in level of satisfaction.

The review of goodness-of-fit measures of model 2 well exceed the recommended cut-off values (Chi-square 61.60; $P = 0.34$; GFI 0.94; AGFI 0.91; NFI 0.90; CFI 0.98; NNFI 0.98; RMSEA 0.02). The loadings of the contingent variables on the coalignment, as shown in model 2, indicate that FORMAL, REGPEU, TQM, JIT, MARKCOM, PMD and SIZESA have significant loadings with path coefficients of 0.52, 0.18, 0.62, 0.29, 0.25, 0.85 and 0.33 respectively (t-values = 6.278, 2.134, 7.728, 3.383, 2.946, 10.895 and 3.866 respectively). Thus, it can be concluded that FORMAL, REGPEU, TQM, JIT, MARKCOM, PMD and SIZESA contribute to the coalignment in model 2. Reviewing the hypothesised model also revealed a significant path coefficient between coalignment and level of satisfaction (beta = 0.54, t-value = 6.308 $P < 0.05$), thus confirming the positive impact of coalignment on level of satisfaction (SATISFAC). The coefficient of determination R^2 of the regression path (coalignment→SATISFAC) is 0.29. This means that the coalignment 'fit' between FORMAL, REGPEU, TQM, JIT, MARKCOM, PMD and SIZESA explains 29% of the variance in level of satisfaction. Thus, it can be concluded that H1b was partially accepted at the 0.05 significance level.

In response to the above results, it should be noted that the fit between cost strategy, formalisation, regulatory-PEU, total quality management, just in time, market competition, the extent of performance measurement diversity usage and size (model 1) and between formalisation, regulatory-PEU, total quality management, just in time manufacturing approaches, market competition, the extent of performance measurement diversity usage and size (model 2) results in higher level of satisfaction of performance measurement system. Thus, in model 1, the extent of performance measurement diversity usage seems to contribute to higher level of satisfaction of performance measurement system in large organisations following a low-cost strategy with a formalised structure, facing uncertainty in regulations and high market competition and using both total quality management and just in time manufacturing approaches. In model 2, a differentiation strategy does not contribute to level of satisfaction. Thus, the extent of performance measurement diversity usage seems to contribute to higher level of satisfaction of performance measurement system in large organisations with formalised structure, facing uncertainty in regulations and high market competition and using both total quality management and just in time manufacturing approaches.

The above results confirm the findings that have emerged in the first stage of analysis (see section 9.2) and provide insights on the relationship between the contingent variables and the extent of performance measurement diversity usage. Interpreting the results that have emerged from testing the hypotheses relating to organisational effectiveness based on comparisons with previous empirical studies is not an easy task because of the lack of consistency in measuring organisational effectiveness, and testing the concept of fit in the previous studies. However, the results of this study show that the extent of performance measurement diversity usage contributes to organisational effectiveness (defined by both organisational performance and level of satisfaction) in organisations employing only a low cost strategy. This finding is not consistent with Govindarajan and Gupta's (1985) argument that the usage of both financial and non-financial performance measures contribute to effectiveness with both business strategies. The results showed that the extent of performance measurement diversity usage contribute to organisational effectiveness (defined by both organisational performance and level of satisfaction) in only formalised organisations. This result contradicts with Chia's (1995) findings, in which he indicated that the sophistication of management accounting in terms of scope, timelines, integration and the level of aggregation contribute to organisational effectiveness in decentralised organisations. The results also showed that the extent of performance measurement diversity usage contribute to organisational effectiveness (defined by both organisational performance and level of satisfaction) in organisations facing uncertainty in regulations. With respect to perceived environmental uncertainty dimensions, this result is partially consistent with Gul's (1991) findings that perceived environmental uncertainty requires broad scope, timely, integrated and aggregated information, and the match between perceived environmental uncertainty and management accounting systems leads to high organisational effectiveness.

The results also indicate that the usage of performance measurement diversity contributes to organisational effectiveness (defined by both organisational performance and level of satisfaction) in organisations facing high market competition. This finding is consistent with the line of argument that multiple performance measures are necessary not only to track the financial performance of the organisation, but that non-financial performance are also required to track customer satisfaction, innovation together with quality production, in order to achieve high effectiveness (Kaplan and Norton, 1996c; Ittner and Larcker, 1998a). The findings also showed that the extent of performance measurement diversity usage contributes to organisational effectiveness (defined by both organisational performance and level of

satisfaction) in large organisations. This result is not consistent with Hoque and James (2000) findings, who did not find a fit between the usage of financial and non-financial performance, organisation size and organisational performance.

Finally, the above results show that the extent of performance measurement diversity usage contributes to organisational effectiveness (defined by both organisational performance and level of satisfaction) in organisations implementing both total quality management and just in time manufacturing approaches. These results confirm the results that have emerged in the literature. For instance, Chenhall (1997) found that the association between total quality management and organisational performance was stronger when using non-financial performance measurements. In addition, Upton (1998) found that the use of non-financial performance measures was significantly greater for just in time organisations, and organisational performance was marginally higher in these organisations.

9.4 Testing the hypotheses relating to factors influencing the extent of balanced scorecard usage (BSCUSE)

In Chapter 4 (section 4.7) studies undertaken to investigate the contingent variables influencing the use of both financial and non-financial performance measures were described. However, the literature review did not identify any similar empirical studies undertaken to examine the influence of various contingent variables on the extent of balanced scorecard usage (see Chapter 5, sub-section 5.2.2). In addition, several efforts were made to ensure that the responding companies were balanced scorecard users and, having done this, the actual extent of balanced scorecard usage was measured through the weighted average usage of the financial and non-financial perspectives that were identified in section B (question B2) of the questionnaire (for further explanations see Chapter 8, sub-section 8.2.9). Thus, Cronbach alpha is not computed for the dependent variable (i.e. the extent of balanced scorecard usage). The potential contingent variables influencing the extent of balanced scorecard usage identified in the hypotheses formulated in Chapter 5 (section 5.5) were also presented in Chapter 8 (section 8.2). Table 9.1 reports Pearson correlation matrix for both the dependent variable (the extent of balanced scorecard usage) and the independent variables.

Table 9.1 Correlation coefficients of the extent of balanced scorecard usage and factors influencing the extent of balanced scorecard usage (Pearson)

	(a)	(b)	(c)	(d)	(e)	(f)	(g)	(h)	(i)	(j)	(k)	(l)	(M)
(a) Balanced scorecard usage (BSCUSE)	1												
(b) Differentiation strategy (DIFFSTR)	.08	1											
(c) Low cost strategy (COSTSTR)	.30*	-.39**	1										
(d) Centralisation (CENTRA)	-.09	-.20	.23	1									
(e) Formalisation (FORMAL)	.46**	.20	.34**	-.07	1								
(f) Operational-PEU (OPEPEU)	-.04	.23	-.19	-.01	-.03	1							
(g) Raw material-PEU (MATPEU)	-.17	.05	.07	-.22	.05	.23	1						
(h) Regulatory-PEU (REGPEU)	.17	.15	.00	.04	-.00	.35**	.36**	1					
(i) Market competition (MARKCOM)	.32*	-.12	.35**	.23*	.11	.25*	-.12	.29*	1				
(j) Product competition (PRODCOM)	.23	-.12	.05	-.01	.03	.05	-.03	.07	.35**	1			
(k) Size (SIZESA)	.40**	.16	.04	-.15	.19	-.05	-.02	.13	.08	-.07	1		
(l) Total quality management (TQM)	.45**	.08	.32*	-.12	.29*	.12	.39**	.49**	.26*	.07	.25*	1	
(m) Just in time (JIT)	.37**	-.18	.30*	-.22	.17	.10	.15	.25*	.29*	.06	.26*	.66**	1

** Correlation significant at $P < 0.01$ (2-tailed)

* Correlation significant at $P < 0.05$ (2-tailed)

The above table shows that formalisation, organisation size, total quality management and just in time manufacturing approaches are significantly correlated ($P < 0.01$) with the extent of balanced scorecard usage, and low cost strategy and market competition are also significantly correlated ($P < 0.05$) with the extent of balanced scorecard usage. Table 9.1 also indicates that differentiation strategy, centralisation, operational-PEU, raw material-PEU, regulatory-PEU, and product competition are not significantly correlated with the extent of balanced scorecard usage. However, it should be noted that correlation coefficients are subject to a number of limitations. In particular, they do not involve a sophisticated exploration of the interrelationships among a set of variables (Pallant, 2001, p. 134). To overcome this limitation, multiple regression analysis⁵ is used to explore the relationship between the extent of balanced scorecard usage (dependent variable) and the contingent variables (independent variables). The 12 independent variables were entered into a regression model with the extent of balanced scorecard usage as the dependent variable. Table 9.2 reports the output from the regression model, which represent the independent variables influencing the extent of balanced scorecard usage.

⁵ See Chapter 6 (sub-section 6.14.4) and Chapter 8 (section 8.4) for an explanation for using the multiple regression analysis.

Table 9.2 Regression analysis for the contingent variables influencing the extent of balanced scorecard usage (BSCUSE)

Independent variables	Unstandardised coefficients		Standardised coefficients	t-value	p-value	Tolerance	VIF
	B	Std. Error	Beta				
Constant	2.849	1.207	-	2.361	.024	-	-
Low cost strategy (COSTSTR)	.090	.111	.131	.819	.418	.477	2.097
Differentiation strategy (DIFFSTR)	.016	.118	.020	.135	.893	.561	1.783
Centralisation (CENTRA)	-.088	.098	-.120	-.902	.373	.687	1.455
Formalisation (FORMAL)	.140	.066	.280	2.126	.040	.702	1.424
Operational-PEU (OPEPEU)	-.003	.087	-.006	-.044	.965	.674	1.484
Raw material-PEU (MATPEU)	-.205	.076	-.379	-2.686	.011	.614	1.630
Regulatory-PEU (REGPEU)	.051	.078	.097	.661	.513	.566	1.767
Market competition (MARKCOM)	.016	.099	.025	.163	.871	.523	1.914
Product competition (PRODCOM)	.123	.081	.186	1.518	.138	.811	1.232
Size (SIZESA)	.350	.149	.147	2.357	.020	.896	1.116
Total quality management (TQM)	.252	.062	.508	4.053	.000	.769	1.301
Just in time (JIT)	.001	.103	.002	.012	.991	.402	2.490
Adjusted R ²	.413						
F	3.816						
Significant	.001						

The overall *F* statistic shown in Table 9.2 is statistically significant at the .001 level. This indicates that the improvement due to fitting the regression model is much greater than the inaccuracy within the model (Field, 2000, p. 147). The adjusted R² indicates that the regression model explains 41.3% of the variance in balanced scorecard usage. R² is influenced by the number of independent variables relative to sample size (Hair et al., 1998). However, several rules have been suggested relating to the number of cases per independent variable. In this context, Hair et al. (1998, p. 182) argued that several rules of thumb have been proposed, ranging from 10 to 15 observations per independent variable to an absolute minimum of 4 observations per independent variable. Therefore, the decision was made to consider the adjusted R².

Multicollinearity causes a problem for multiple regression, since it can affect the parameters of a regression model (Field, 2000). According to Hair et al. (1998, p. 191), there are three recommended methods for assessing multicollinearity: (1) the presence of high correlation (generally 0.90 and above), (2) the tolerance values, (3) the variance inflation factor values. However, the three tests for multicollinearity (see Tables 9.1 and 9.2) showed no high correlation values, the variance inflation factor (VIF) showed no values that exceed the generally accepted maximum level of 10 (an indication of high levels of multicollinearity) and the tolerance values showed no values less than the maximum level of 0.2 (also an indication of high levels of multicollinearity). Thus, no support was found for the existence of multicollinearity problem. In addition, to check for the outliers to determine if the regression model was biased, standardised residuals and Cook's distance were used. The tests indicated that less than 5% of the sample has no standardised residuals with an absolute value more than 2, which is considered acceptable based on Field (2000). The Cook's distance showed no values that exceed the accepted maximum level of 1 (an indication of high level of influential cases). Finally, the Durbin-Watson test was undertaken to test if the residuals were correlated. The test indicated a value of 1.980, which is considered between the acceptable levels (less than 1 or greater than 3 are deemed to be unacceptable).

In addition to the aforementioned there are several decision rules for accepting or rejecting research hypotheses. The most important basis for accepting or rejecting the hypotheses is the significance of the standardised coefficient (beta). This measure shows us the relationship between the dependent variable and each of the independent variables (Field, 2000). The critical t-value based on the level of significance (α). To recall from the discussion in Chapter 8 (sub-section 8.4.5), the decision was made to adopt the traditional level of significance ($\alpha = 0.05$) in this research. Moreover, it should be noted that apart from organisational structure, directional relationships are hypothesised to address the effect of contingent variables on the extent of balanced scorecard usage. Therefore, a one-tailed test of significance was used for all of the variables apart from organisational structure, where a two-tailed test of significance was used, to examine their influence on the extent of balanced scorecard usage.

The hypotheses within this section focus on examining the relationships between the contingent variables (i.e. low cost strategy, differentiation strategy, centralisation, formalisation, operational-PEU raw material-PEU, regulatory-PEU, market competition, product competition, organisation size, total quality management, and just in time

manufacturing approaches) and the extent of balanced scorecard usage (BSCUSE). Thus, the results of multiple regression analysis are now presented.

H1a: *Low cost strategy has a negative impact on the extent of balanced scorecard usage.*

H1b: *Differentiation strategy has a positive impact on the extent of balanced scorecard usage.*

As shown in Table 9.2, the statistics relating to hypothesis H1a reveal that low cost strategy (COSTSTR) has no significant effect on the extent of balanced scorecard usage (BSCUSE) with a beta of 0.131 (t-value = 0.819). Similarly the statistics relating to hypothesis H1b indicate that differentiation strategy (DIFFSTR) has no significant effect on the extent of balanced scorecard usage (BSCUSE) with a beta of 0.020 (t-value = 0.135). Thus, the findings of the regression model indicate that hypotheses H1a and H1b, which predict a direct relationship between each of low cost and differentiation strategies and the extent of balanced scorecard usage, were not supported at 0.05 significance level. Therefore, both hypotheses are fully rejected.

The findings of the regression model imply that differentiation strategy has no significant impact on the extent of balanced scorecard usage. It was argued in the literature that the increasing use of non-financial performance measures is relatively high in differentiator companies. In other words, it is expected that companies will use the balanced scorecard approach if they were differentiators. Therefore, it can be concluded that adopting this type of strategy is not related to the extent of balanced scorecard usage in the UK manufacturing companies. The findings of the regression model also imply that low cost strategy has no significant impact on the extent of balanced scorecard usage. It was argued in the literature that the use of non-financial performance measures is negatively associated with companies adopting low cost strategy. In other words, it is expected that companies will not use the balanced scorecard approach if they were adopting low cost strategy. Therefore, it can be concluded that adopting this type of strategy is also not related to the extent of balanced scorecard usage in the UK manufacturing companies.

The aforementioned results contradict the arguments presented in the management accounting literature. In this vein, Abernethy and Lillis (1995) argued that the choice of

performance measurements is dependent on business strategy, and the nature of performance measurements is different according to business strategy (Cauvin and Bescos, 2002).

An interpretation of these findings could be that different companies experience different sets of managers' decisions to adopt and use management accounting innovation (Gosselin, 1997). In addition, Shank (1989) argues that companies prefer using management accounting techniques under differentiation or low cost strategies, therefore, different managerial decisions underlying both strategies may influence preferences for using particular management accounting techniques. Thus, it can be concluded that different managerial decisions underlying low cost and differentiation strategies may not influence the extent of balanced scorecard usage. Finally, it should be noted that the aforementioned results partially contradict with the findings that emerged in section 9.3, in which only low cost strategy was found to affect the extent of performance measurement diversity usage (financial and non-financial performance measures).

Research question 1: *Does the structural dimension of centralisation have a direct impact on the extent of balanced scorecard usage?*

Research question 2: *Does the structural dimension of formalisation have a direct impact on the extent of balanced scorecard usage?*

As shown in Table 9.2, the statistics relating to research question 1 reveal that centralisation (CENTRA) has a negative but non-significant impact on the extent of balanced scorecard usage (BSCUSE) with a beta of -0.120 (t-value = -0.902). Thus, the findings of the regression model indicate that research question 1, which predicts a direct relationship between the centralisation dimension of structure and the extent of balanced scorecard usage is not supported at the 0.05 significance level. Based on this result, it can be concluded that centralisation has no impact on the extent of balanced scorecard usage. Centralisation refers to the hierarchical level that has the authority to make decisions. Therefore, it can be concluded that manufacturing companies with centralised decision-making has no affect on the extent of balanced scorecard usage. The negative and non-significant effect of centralisation on the extent of balanced scorecard usage contradicts with the argument presented by Braam and Nijseen (2004a) in which they argue that the chance of balanced scorecard adoption is more likely in high centralised companies. In addition, this result

contradicts Gosselin's (1997) findings, who reported that the implementation of activity-based costing system is associated with centralised decision-making.

The statistics relating to research question 2 reveal that formalisation (FORMAL) has a positive impact on the extent of balanced scorecard usage (BSCUSE) with a beta of 0.280 (t-value = 2.126). Thus, the findings of the regression model indicate that research question 2, which predicts a direct relationship between formalisation dimension of structure and the extent of balanced scorecard usage is supported at the 0.05 significance level. The literature on the balanced scorecard supports the above result in which organisation structure provides the infrastructure on which organisations can adopt the balanced scorecard (Letza, 1996). Formalisation refers to the amount of procedures, job descriptions and regulations. Thus, it can be concluded that formalised and structured organisations should be complemented with non-financial performance measurements in order to deal with the negative effects of formalisation. In other words, the balanced scorecard should be derived from an organisation's strategic objectives and designing a balanced scorecard should involve several recommended steps (Kaplan and Norton, 1993). In addition, Burns and Scapens (2000) have argued that management accounting systems and practices are organisational rules and routines, and these rules are the formally recognised way to do things, thus, implementing the balanced scorecard approach for example could be well established in a set of rules to avoid the knowledge being lost, to facilitate training staff, or to exercise control over any modifications. Therefore, it is expected that formalised and structured organisations which rely heavily on the amount of written documentation in the organisation, including regulations and procedures, will use the balanced scorecard. Finally, it should be noted that the aforementioned results are similar to the findings that were reported in section 9.3.

H2: *Perceived environmental uncertainty has a positive impact on the usage of the balanced scorecard.*

With respect to the effect of perceived environmental uncertainty dimensions of operational-PEU (OPEPEU), raw material-PEU (MATPEU) and regulatory-PEU (REGPEU) on the extent of balanced scorecard usage, the statistics relating to hypothesis H2 reveal that OPEPEU has a negative and non-significant effect on the extent of balanced scorecard usage (BSCUSE) with a beta of -0.006 (t-value = -0.044). REGPEU also has a non-significant effect on the extent of balanced scorecard usage (BSCUSE) with a beta of 0.097 (t-value =

0.661), while, MATPEU has a negative and significant effect on the extent of balanced scorecard usage (BSCUSE) with a beta of -0.379 (t-value = -2.686). Thus, H2 was rejected for both OPEPEU and REGPEU, while, H2 was partially supported for the effect of MATPEU on the extent of BSCUSE (but in the inverse direction).

Surprisingly, the results of the regression model (see Table 9.2) showed mixed and inverse results regarding the effect of PEU dimensions on the extent of balanced scorecard usage. However, these negative and lack of significant effects of PEU dimensions are not consistent with Chenhall and Morris (1996) empirical findings that indicate that increasing levels of perceived environmental uncertainty lead to a greater need for management accounting information in terms of non-financial performance measurements. The results are also not consistent with Chow et al. (1997) theoretical argument that the application of the balanced scorecard has been mostly reported in organisations facing turbulent environment.

Interpretations of these results may contradict the early arguments that have confirmed the positive relationship between the use of non-financial performance measurements and perceived environmental uncertainty. However, one could argue that the level of perceived environmental uncertainties makes no difference to the extent of balanced scorecard usage which emphasises using non-financial performance measures. Recent empirical research however, has reported that balanced scorecard users face less uncertainty in their environment (Banker et al., 2001). Finally, it should be noted that the operationalisation of perceived environmental uncertainty represent the perceptions of managers, and this may not perceive the actual level of uncertainties in the external environment (see Chapter 5, sub-section 5.4.1.3). In addition, the aforementioned results raise the question of whether researchers should perceive environment uncertainty as a multidimensional construct.

H3: *The intensity of competition has a positive impact on the extent of balanced scorecard usage.*

With respect to the effect of intensity of competition dimensions of market competition (MARKCOM) and product competition (PRODCOM) on the extent of balanced scorecard usage, the statistics relating to hypothesis H3 reveal that both dimensions of MARKCOM and PRODCOM have no significant effect on the extent of balanced scorecard usage (BSCUSE) with betas of 0.025 and 0.186 respectively (t-values = 0.163 and 1.518

respectively). The results of the regression model show that intensity of competition has no significance impact on the extent of balanced scorecard usage. Thus, hypothesis H3 is fully rejected.

Surprisingly, the literature on balanced scorecard contradicts the above result. In this context, Kaplan and Norton (1992) argued that the balanced scorecard is a more appropriate approach when the level of market competition is high. This result is also not consistent with the empirical work by Banker et al., (2001) who found that companies implementing the balanced scorecard operate in competitive markets and face high competitive pressure. Interpretations of this contradictory result is not an easy task, taking into consideration that earlier studies have confirmed the relationship between intensity of competition and the use of multiple performance measurements (e.g. Euske et al., 1993; Hoque et al., 2001). However, one could argue that companies are using the non-financial performance measurements as a call for using these measures that are the origin of management accounting systems (Johnson and Kaplan, 1987) and not just a response to the increased level of competition. However, this result is similar to the results reported in the previous hypothesis that have confirmed the contradictory results of the impact of perceived environmental uncertainty dimensions⁶. A possible explanation for the non-significant relationship is that companies facing high competition might be more cost conscious and reluctant to invest in costly management accounting systems when it cannot be clearly demonstrated that such decisions will yield positive short-term returns. Finally, it should be noted that the aforementioned results contradict with the findings that emerged in section 9.3, in which intensity of competition dimensions were found to affect the extent of performance measurement diversity usage (financial and non-financial measures).

H4: *Organisation size has a positive impact on the extent of balanced scorecard usage.*

The statistics relating to H4 revealed that organisation size (SIZESA) has a positive impact on the extent of balanced scorecard usage (BSCUSE) with a beta of 0.147 (t-value = 2.357). Thus, the findings of the regression model revealed that H4, which predicts a direct relationship between organisation size and the extent of balanced scorecard usage was supported at the 0.05 significance level. The literature on balanced scorecard supports the

⁶ Competition was one of the operational-PEU dimensions.

above result in which balanced scorecard usage is significantly associated with larger organisations. It has been argued that the possible reason for the positive relationship between organisation size and the adoption of management accounting innovation is that larger organisations have relatively more resources to use new systems (Drury, 2002). In the empirical work by Hoque and James (2000), Lawson et al. (2003b) and Speckbacher et al. (2003), organisation size is positively associated with balanced scorecard usage.

As this result is significant with a positive direction, it can be concluded that larger organisations have more abilities and capabilities to deal with management accounting innovation. In contrast, smaller organisations require less elaborate performance evaluation techniques because the strategy setters are more likely to be directly assess the extent to which strategy is being achieved (Hoque and James, 2000, p. 3). Thus, it can be concluded that larger organisations are likely to make more use of the balanced scorecard. This suggests that as organisations size increase, managers find it more useful and practical to place greater emphasis on the balanced scorecard that supports their strategic decisions, as this approach incorporates both financial and non-financial performance measurements. Finally, it should be noted that the aforementioned result is similar to the findings that emerged in section 9.3.

H5: *Extent of the use of total quality management has a positive impact on the extent of balanced scorecard usage.*

The statistics relating to H5 revealed that extent of the use of total quality management (TQM) has a positive impact on the extent of balanced scorecard usage (BSCUSE) with a beta of 0.508 (t-value = 4.053). Thus, the findings of the regression model indicate that H5, which predicts a direct relationship between extent of the use of total quality management and the extent of balanced scorecard usage is supported at 0.05 significance level.

It has been argued in Chapter 4 (sub-section 4.7.6.1) that non-financial performance measurements are appropriate in total quality management settings. In addition, the management accounting literature has supported the idea that organisations implementing total quality management initiatives are associated with a greater use of non-financial performance measurements. Total quality management refers to the ability to achieve and sustain a continuous improvement through customer satisfaction, quality and participation (Dale et al., 1997). The literature on the balanced scorecard supports the above result in

which the use of total quality management has a positive impact on the extent of balanced scorecard usage. It has been argued that today's manufacturing environment can be characterised by intensified competition, market changes and high customer demand. These conditions require a manufacturing company to concentrate more on continuously improving quality and the aspects of total quality management (Johnson and Kaplan, 1987). The TQM concept and implications are consistent with the increasing use of non-financial performance measurements (Banker et al., 1993; Perera et al., 1997). Thus, it can be expected that companies that pursue TQM are more likely to use the balanced scorecard approach. Empirical work by Malmi (2001) supported the proposition that one of the important initiatives that encourage the adoption of the balanced scorecard is the use of total quality management. Finally, it should be noted that the aforementioned result is similar to the findings that emerged in section 9.3.

H6: *The extent of the use of just in time manufacturing approaches has a positive impact on the extent of balanced scorecard usage.*

The statistics relating to H6 reveal that extent of the use of just in time manufacturing approaches (JIT) has no significant effect on the extent of balanced scorecard usage (BSCUSE) with a beta of 0.002 (t-value = 0.012). Thus, the findings of the regression model indicate that H6, which predicts a direct relationship between extent of the use of just in time and the extent of balanced scorecard usage is not supported at 0.05 significance level.

In sub-section 4.7.6, it has been argued that non-financial performance measurements are appropriate for organisations applying advanced manufacturing technologies. In contrast with the positive direct effect of total quality management on the extent of balanced scorecard usage, the extent of use of just in time manufacturing approaches has no effect on the extent of balanced scorecard usage. Surprisingly, the literature on balanced scorecard contradicts the above result. In this context, Clinton and Hus (1997) argued that the balanced scorecard approach can systemise the management control system to cope with the changes in activities that relate to the implementation of a JIT manufacturing approach. However, the interpretations of this contradictory result is not an easy task, taking into consideration that earlier studies have confirmed the relationship between just in time manufacturing approach and the increasing use of non-financial performance measurements (e.g. Upton, 1998; Fullerton and McWatters, 2002). Thus, one could argue that implementing just in time

manufacturing approach is not related to using the balanced scorecard but this does not imply that companies are not using the non-financial performance measures in their performance measurement systems. In other words, JIT companies are not using the balanced scorecard to significantly greater extent than non-JIT companies. Finally, it should be noted that the aforementioned result contradicts with the findings that emerged in section 9.3, in which JIT manufacturing approaches was found to affect the extent of performance measurement diversity usage.

9.5 Summary

This chapter has presented the procedures, findings and discussion emerging from the data analysis of this research. The first stage of analysis (using SEM) focused on investigating the relationship between the contingent variables and the extent of performance measurement diversity usage (PMD) represented in the first research theoretical model (Figure 5.1) and discussed in Chapter 5. Due to the complexity of the model, twelve structural model analyses were constructed to investigate the direct and indirect effects of the contingent variables on PMD usage. The second stage of analysis (using SEM) was concerned with investigating the fit between all the contingent variables and the extent of performance measurement diversity usage on organisational effectiveness (i.e. in terms of organisational performance and level of satisfaction). The data were screened to check for missing values and outliers. Out of 163 cases, one case was identified as outlier, and then was deleted from the analysis.

The third and final stage of analysis was concerned with investigating the relationship between the contingent variables and the extent of balanced scorecard usage (BSCUSE) represented in the second research theoretical model (Figure 5.2) and discussed in Chapter 5. Correlations and multiple regression were conducted under this stage to investigate these relationships. Based on the related literature, a thorough discussion for each finding was presented in this chapter to justify the logic behind all the results that emerged from the data analysis of the aforementioned stages. However, a summary and a discussion of the research findings that has emerged from the three stages of analysis and their implications for theory and practice will be presented in the next chapter.

Chapter 10

Conclusions and implications

10.1	Introduction.....	10-2
10.2	Summary of the research findings.....	10-4
10.2.1	The results of the descriptive statistics.....	10-4
10.2.2	The results of hypotheses testing relating to factors influencing the extent of performance measurement diversity usage.....	10-10
10.2.3	The results of hypotheses testing relating to the effectiveness of performance measurement diversity usage.....	10-12
10.2.4	The results of hypotheses testing relating to factors influencing the extent of balanced scorecard usage.....	10-12
10.3	Implications of research findings to knowledge.....	10-14
10.3.1	Implications for academics.....	10-14
10.3.2	Implications for managers.....	10-17
10.4	Limitations and further research agenda.....	10-18
10.5	Conclusion.....	10-23

Chapter 10

Conclusions and implications

10.1 Introduction

It should be recognised at the outset that the environment in which management accounting is practised has changed arising from advances in information technology, competitive markets, different organisational structures and new management practices (Burns and Scapens, 2000, p. 3). In response to these changes, organisations are now placing more emphasis on incorporating non-financial performance measures into their performance measurement systems and this has been a major motivation to examine this process by conducting this study.

This study is an attempt to provide a better understanding of performance measurement implications and uses through several dimensions (i.e. importance to long-term success, setting strategic goals, managerial performance evaluation, financial rewards system, identification of improved opportunities and the development of action plans, and measurement quality). An effort was made in this study to provide a better understanding of how UK manufacturing companies are dealing with the balanced scorecard concept. In addition, this study has utilised the contingency theory theoretical framework to examine the contingent relationships between business strategy, organisational structure, perceived environmental uncertainty, intensity of competition, organisation size, total quality management, just in time manufacturing approaches and the extent of usage of both performance measurement diversity and balanced scorecard. Furthermore, this study has examined the implications of the internal consistency 'fit' between the contingent variables and the extent of performance measurement diversity usage on organisational effectiveness.

In addition, the study has utilised and redefined and then expanded the previous work presented in the field of management accounting by several researchers relating to performance measurement diversity. An examination of the literature indicated that the determination of the extent of balanced scorecard usage varies between researchers. In this context, researchers (e.g. Ittner, Larcker and Randall, 2003; Speckbacher et al., 2003) have measured the extent of balanced scorecard usage by using a self-rating question of the stages of balanced scorecard implementation. Other researchers (e.g. Hoque and James, 2000;

Olson and Slater, 2002) have defined the extent of balanced scorecard usage as multi-perspective sets of both financial and non-financial performance measures. Therefore, it can be noted that no reliable statement can be made from previous research about how this approach has been implemented by companies because many of balanced scorecard concepts and relationships are open to several interpretations (e.g. types and number of perspectives). Thus, developing a valid measure of the extent of balanced scorecard usage would be useful to both academic and researchers to further explore its context (Chenhall, 2003; Norreklit, 2003).

This study builds on the works of the aforementioned researchers in terms of developing a wider, accurate and comprehensive view of the extent of balanced scorecard usage. Thus, three stages have been utilised to determine the actual extent of balanced scorecard usage. The first stage was used to identify if the responding companies are really adopting the balanced scorecard concept. The second stage was designed to determine the actual perspectives that have been used by the responding companies in their balanced scorecard. The third stage was utilised to ensure that the selected perspectives are really used in performance measurement and evaluation purposes, the weighted average of these perspectives was then calculated¹. Finally, this study is one of the first to incorporate several contingent variables in one model and investigate their effect on the extent of balanced scorecard usage.

It was pointed out in Chapters 1 and 5 that the major objectives of this research were:

1. To ascertain the extent of usage of a broader set of financial and non-financial performance measures and their implications in UK manufacturing companies.
2. To determine the relationship between various contingent variables and the extent of performance measurement diversity usage.
3. To examine the relationship between the contingent variables, the extent of performance measurement diversity usage and organisational effectiveness.
4. To ascertain how UK manufacturing companies apply the balanced scorecard approach.
5. To determine the relationship between various contingent variables and the extent of balanced scorecard usage.

¹ See Chapter 8 (sub-section 8.2.9) for an explanation.

To achieve the above objectives, a questionnaire survey was performed to quantify the factors of interests and to examine the hypothesised relationships between the independent variables (i.e. contingent variables) and the dependent variables (i.e. the extent of usage of both performance measurement diversity and balanced scorecard), and to examine whether the fit between the contingent variables and the extent of performance measurement diversity usage is associated with greater organisational effectiveness.

Descriptive statistical analysis using means and percentages were utilised to achieve the first and fourth objectives of the research. Multivariate statistical techniques using structural equation modelling (SEM) and multiple regression were also utilised in this research to achieve the remaining three objectives (i.e. the second, third and fifth). This chapter presents a summary of the major findings emerging from this research arising from the descriptive and analytical statistics. Also, the major contributions of this research to both academics and managers are presented. In addition, the limitations of this research are outlined followed by suggestions relating to future research agenda.

10.2 Summary of the research findings

Two types of results have been reported in this study. First, the descriptive results which show how UK manufacturing companies are using financial and non-financial performance measures (i.e. financial, customer, operational, innovation, employee, supplier, environment, quality and community) in their performance measurements and evaluation, and how these companies are dealing with the balanced scorecard concept. Second, the analytical results which have supported the research theoretical models (see Chapter 5, sub-sections 5.2.1 and 5.2.2). The results are presented in the following sub-sections.

10.2.1 The results of the descriptive statistics

It has been mentioned in the previous section that descriptive statistics were used to meet the first and fourth objectives of this study. This was achieved by extending previous studies along several dimensions:

- Examining the importance of a broader set of performance measurements to long-term organisational success and their corresponding use in performance measurement and evaluation purposes (i.e. managerial performance evaluation, financial rewards and the

identification of improvement opportunities and development of action plans), setting strategic goals and quality of these performance measurements.

- Investigating how manufacturing companies are dealing with the balanced scorecard approach.

For the purposes of the first objective, the results suggest that financial performance categories are the most important drivers of long-term success in the UK manufacturing companies. The results indicate that the responding companies emphasise the importance of the following non-financial performance categories to long-term success of businesses: customer, quality, operational, innovation, supplier, employee and the environment as drivers of long-term organisational success. The responding companies also emphasise setting strategic goals relating to financial, quality, customer, operational, innovation, supplier, and employee performance measurements. The results also indicate that the companies highly rate the quality of their performance measures relating to financial, quality, customer, operational, employee, and supplier performance categories.

In terms of using financial and non-financial performance categories in performance measurements and evaluation, the results indicate that financial, operational, quality and customer performance categories are the only categories that have been widely used in the overall evaluation of managerial performance. However, only financial and operational performance categories were found to be widely used in the financial reward system in manufacturing companies. The results also indicate that financial, quality, customer, operational, employee, and supplier performance categories are used to identify problems and improvement opportunities and develop action plans.

In addition to the aforementioned results, the following indicators give a strong insight into the performance measurement categories operated by UK manufacturing companies:

- Financial and operational performance categories are the only performance categories that have been used by the responding companies in all performance measurement and evaluation purposes (i.e. managerial performance evaluation, financial rewards and the identification of improvement opportunities and development of action plans), setting strategic goals and considering these performance measurements to be of a high quality.

- Environment and community are the only performance categories that have not been used by the responding companies in all performance measurement and evaluation purposes (i.e. managerial performance evaluation, financial rewards and identification of improvement opportunities and development of action plans), setting strategic goals and measurement quality.
- Customer and quality performance categories are used by the responding companies in the following performance measurement and evaluation purposes (i.e. managerial performance evaluation and identification of improvement opportunities and development of action plans), setting strategic goals and considering these performance measurements to be of a high quality.
- Employee and supplier performance categories are used by the responding companies in the following performance measurement and evaluation purposes (i.e. identification of improvement opportunities and development of action plans), setting strategic goals and considering these performance measurements to be of a high quality.

The results show that the importance of all performance measurement categories to long-term organisational success listed in section 10.2 is significantly correlated with their perceived use in performance measurement and evaluation purposes, setting strategic goals and quality of these performance measurements. The results also show a clear indication that the use of all performance categories in all performance measurement and evaluation purposes, setting strategic goals and the level of quality of these performance measurements are significantly correlated. Even when there are significant correlations, the results provide information on the differences (i.e. the measurement gap) between the perceived importance of the financial and non-financial performance measurements, the corresponding use, setting strategic goals and the level of quality of these performance measurements. Not surprisingly, the average scores of (1) the use of each performance measurements in performance measurement and evaluation purposes, (2) strategic goals are established for each performance measurement, and (3) the level of quality of measurements are lower than the importance scores for each performance measurement. Thus, with no exceptions to any performance measurement category, it can be concluded that substantial measurement gaps exist for all performance measurement categories, indicating that the use of performance measurements for one purpose does not imply that the measurements are used for other purposes. These differences are consistent with the measurement gaps identified in several empirical studies (e.g. Stivers et al., 1998). Consequently, the following notions can be concluded from the above results:

- Financial performance categories are viewed as important for long-term success of businesses, thus they are widely used by the responding companies in all performance measurements and evaluation.
- Non-financial performance measures falling within each performance category are viewed as important for long-term organisational success, but they may not be used in all performance measurements and evaluation. However, customer, operational and quality performance measurements are identified as the most predominant non-financial performance measurements used by the responding companies in performance measurements and evaluation. Innovation, employee, supplier, and environment performance measurements have also been moderately used by the responding companies in performance measurements and evaluation.

Thus, it can be concluded that financial performance measures continue to be an important aspect of performance measurements and evaluation. These measures are supplemented with several non-financial performance measures. However, the type of non-financial performance measures used by the companies depends on the perceived usefulness of the information that may result from using these measures in performance measurements and evaluation. Finally, the majority of the respondents support the notion that performance measures used in performance measurements and evaluation are linked to their business unit's strategies. Also, the majority of the respondents indicate that these performance measures are linked to each other and to future financial outcomes. However, it should be noted that in this study the respondents were not asked how their companies actually link performance measures to business unit's strategies on the one hand, and how they establish the connections between non-financial performance measures and financial performance on the other hand. Therefore, these two results should be treated with caution.

For the purposes of the second research objective, the results show that approximately 42% of the responding companies had not considered the balanced scorecard approach in their performance measurement system and 23% are now considering this approach. In addition, the results also report that 2.5% of the responding companies had implemented and abandoned this approach, while, 1.8% had approved this approach for implementation. Despite its popularity, only 30.1% of the responding companies (N = 49) had implemented the balanced scorecard approach. This result may be justified based on the idea that there are companies frequently using several types of scorecards. In addition, different opinions exist

on the characteristics of the balanced scorecard approach. However, to provide further insights on these issues, the following indicators show the characteristics and contents relating to how UK manufacturing companies are implementing this approach:

- An essential feature of balanced scorecard approach is the type of performance perspectives. However, the results indicate that the majority of the balanced scorecard companies are using the first three perspectives of Kaplan and Norton's balanced scorecard (i.e. financial, customer, and internal business process/operational) in their balanced scorecards. Approximately 38% of the balanced scorecard companies use the learning and growth/innovation perspective. Interestingly, the balanced scorecard companies also use additional perspectives (i.e. employee, supplier, environment and quality with a percentage usage of 65.3%, 44.9%, 26.5%, and 6.1% respectively). These results support the idea that companies are using different types of performance perspectives that mainly cope with their objectives.
- Another core feature of balanced scorecard approach is the number of perspectives used. Approximately one quarter of the balanced scorecard companies are using only four performance perspectives, while, more than fifty percent of the balanced scorecard companies declared using more than four performance perspectives. Interestingly, 14.2% of the balanced scorecard companies declared using less than four perspectives. These results suggest that the majority of the balanced scorecard companies use different combinations of performance perspectives. This is consistent with the idea suggested by researchers such as Olve et al. (1999) and Malmi (2001) that the number of performance perspectives used by companies is always situational.
- The results indicate that all the balanced scorecard companies use a wide range of strategic objectives and performance measures ranging from one to ten for each perspective. Thus, it can be concluded that balanced scorecard companies can formulate and use performance measures that stem from business strategy to achieve companies' objectives.
- It has been argued in the literature that there are several attributes associated with implementing the balanced scorecard, however, this study has classified these attributes into four components. First, the usage of strategic measures and/or objectives. The results indicate that all balanced scorecard companies are using strategic measures or strategic objectives. Second, the cause-and-effect relationships. The results indicate that most of the balanced scorecard companies are able to formulate cause-and-effect

relationships among their objectives and measures. Third, the usage of action plans and targets. The results indicate that approximately half of the balanced scorecard companies already use action plans or targets for their strategy implementation. Finally, the results indicate that 34.6% of balanced scorecard companies have linked their reward system to balanced scorecard measures.

- The findings indicate that approximately half of the balanced scorecard companies agreed with the notion that using this approach sustains companies in achieving operational results as well as several organisational benefits (e.g. process improvements and communications), while, 16.3% of balanced scorecard companies indicated that they have achieved quantifiable financial results. Not surprisingly, 18.4% of balanced scorecard companies indicate that it's too early to ascertain its impact on the results and 4.1% of the balanced scorecard companies assert on the idea that there is no results associated with using this approach.
- The results indicate that the balanced scorecard approach is implemented within several organisational levels. However, the majority of balanced scorecard companies are applying this approach at the business unit level. Also, approximately half of the balanced scorecard companies are applying this approach at the corporate level. The results also indicate an increasing rate of implementation at several lower organisational levels such as plant level, department level, team level, and employee level. Thus, it can be concluded that this approach can be applied at different levels to communicate strategy between organisational members.

The results suggest that there are several significant differences between balanced scorecard users and non-users in terms of the perceived importance of the financial and non-financial performance categories and their corresponding uses in performance measurement and evaluation purposes (i.e. financial reward system and problem identification and developing action plans) setting strategic goals and the quality of performance measures. These significant differences relate only to employee, supplier, customer, innovation, environment, community, and quality performance categories. Thus, it can be concluded that companies claiming to use the balanced scorecard are using the information relating to these performance categories in performance measurements and evaluation more than non-users. In addition, the results suggest that the idea of linking performance measures to business strategy and the cause and effect relationships is higher across the balanced scorecard companies compared with non-balanced scorecard companies. The findings thus suggest that

balanced scorecard companies are placing more emphasis on the two important assumptions of the balanced scorecard more than companies who do not use this approach. The results also suggest that balanced scorecard companies have achieved a moderately greater satisfaction of their performance measurement system compared with non- balanced scorecard companies. Finally, the results show that apart from textile, cotton, wool, and clothing industry, the usage of the balanced scorecard is high across all types of manufacturing industries. In addition, the results suggest that there are no significant differences in the usage of the balanced scorecard across the manufacturing industry. Thus, it can be concluded that the usage of the balanced scorecard tends to be fairly uniform across manufacturing industry.

10.2.2 The results of hypotheses tests relating to factors influencing the extent of performance measurement diversity usage

Structural equation modelling was utilised to test this set of hypotheses to achieve the second objective of this research (the investigation of the impact of business strategy, organisational structure, perceived environmental uncertainty, intensity of competition, organisation size, total quality management and just in time manufacturing approaches on the extent of performance measurement diversity usage). A summary of this set of hypotheses and their results is presented in Table 10.1. These results suggest that several contingent variables have different effects on the extent of performance measurement diversity usage (PMD).

Table 10.1 Summary of the research hypotheses relating to factors influencing the extent of performance measurement diversity usage

Hypotheses relating to factors influencing the extent of performance measurement diversity usage	The extent of performance measurement diversity usage (PMD)			
	Expected	Beta	t-value	Comment
<u>Business strategy</u>				
- Low cost strategy (H1a)	-	0.50*	3.185	Accepted
- Differentiation strategy (H1b)	+	0.08	0.759	Rejected
<u>Organisational structure</u>				
- Centralisation (Research question 1)	N/A	-0.12	-1.072	Rejected
- Formalisation (Research question 2)	N/A	0.66*	3.548	Accepted
<u>Perceived environmental uncertainty</u>				
- Operational-peu (H2)	+	-0.10	-0.993	Partially accepted
- Material-peu (H2)	+	-0.18	-1.211	
- Regulatory-peu (H2)	+	0.21*	2.167	
<u>Intensity of competition</u>				
- Market competition (H3)	+	0.30*	2.392	Accepted
- Product competition (H3)	+	0.23*	2.184	
<u>Organisation size (H4)</u>	+	0.41*	3.903	Accepted
<u>Total quality management (H5)</u>	+	0.72*	4.926	Accepted
<u>Just in time manufacturing approaches (H6)</u>	+	0.38*	2.962	Accepted

* $P < 0.05$; N/A = Not hypothesised/research question

The results summarised in Table 10.1 are presented as follows:

- Low cost strategy has a positive impact on the extent of using performance measurement diversity (i.e. financial and non-financial performance measures).
- The results indicate a direct, positive and non-significant impact of differentiation strategy on the extent of performance measurement diversity usage.
- The results indicate a direct, negative, and non-significant impact of centralisation on the extent of performance measurement diversity usage.
- A positive significant relationship was found between formalised organisations and the extent of performance measurement diversity usage.
- The results summarised in Table 10.1 indicate a negative, non-significant impact in respect of both operational and raw-material dimensions of perceived environmental uncertainty on the extent of performance measurement diversity usage. However, a positive significant relationship was found between the regulatory dimension of perceived environmental uncertainty and the extent of performance measurement diversity usage.
- A significant positive relationship was found between the intensity of competition dimensions and the extent of performance measurement diversity usage.
- Organisation size has a positive significant impact on the extent of performance measurement diversity usage.
- Total quality management has a positive significant impact on the extent of performance measurement diversity usage.
- Just in time manufacturing approaches has a positive significant impact on the extent of performance measurement diversity usage.

It should be noted that all the results presented in Table 10.1 were confirmed through the indirect relationships between the aforementioned contingent variables and each of performance measurement categories (i.e. financial, customer, innovation, operational, employee, supplier, environment, quality, community). These results were presented and discussed in Chapter 9 (section 9.2).

10.2.3 The results of the hypotheses tests relating to the effectiveness of performance measurement diversity usage

It was pointed out that this study employed the systems approach of fit to achieve the third research objective concerned with investigating the internal consistency among dimensions of business strategy, organisational structure, perceived environmental uncertainty, intensity of competition, organisation size, total quality management, just in time manufacturing approaches and the extent of performance measurement diversity usage and organisational effectiveness. It was indicated in Chapter 5 (sub-section 5.4.4) that this study operationalised organisational effectiveness through organisational performance (i.e. financial and non-financial performance measures) and the level of satisfaction of performance measurement system. The results of this analysis were presented and discussed in Chapter 9 (section 9.3). The major findings indicate that greater performance measurement diversity contributes to organisational performance in large organisations following a low cost strategy with formalised structures facing both high uncertainty in regulations and market competition and using both total quality management and just in time manufacturing approaches to a great extent. The results from the analysis also indicate that greater performance measurement diversity in large organisations following a low cost strategy with formalised structures facing high uncertainty in regulations and high market competition and using both total quality management and just in time manufacturing approaches to a great extent results in higher levels of performance measurement system satisfaction.

10.2.4 The results of the hypotheses tests relating to factors influencing the extent of balanced scorecard usage

It was pointed out in Chapter 8 (section 8.4) that multiple regression was utilised instead of structural equation modelling to test this set of hypotheses to achieve the fifth and final objective of this research (the investigation of the impact of business strategy, organisational structure, perceived environmental uncertainty, intensity of competition, organisation size, total quality management, and just in time manufacturing approaches on the extent of balanced scorecard usage). A summary of this set of hypotheses and their results is presented in Table 10.2. These results suggest that several contingent variables have different effects on the extent of balanced scorecard usage. It should be noted that all the results presented in Table 10.2 were presented and discussed in Chapter 9 (section 9.4).

Table 10.2 Summary of the research hypotheses relating to factors influencing the extent of balanced scorecard usage

Hypotheses relating to factors influencing the extent of balanced scorecard usage	The extent of balanced scorecard usage (BSCUSE)			
	Expected	Beta	t-value	Comment
Business strategy				
- Low cost strategy (H1a)	-	0.131	0.819	Rejected
- Differentiation strategy (H1b)	+	0.020	0.135	Rejected
Organisational structure				
- Centralisation (Research question 1)	N/A	-0.120	-0.902	Rejected
- Formalisation (Research question 2)	N/A	0.280*	2.126	Accepted
Perceived environmental uncertainty				
- Operational-peu (H2)	+	-0.006	-0.044	Partially accepted
- Material-peu (H2)	+	-0.379*	-2.686	
- Regulatory-peu (H2)	+	0.097	0.661	
Intensity of competition				
- Market competition (H3)	+	0.025	0.163	Rejected
- Product competition (H3)	+	0.186	1.518	
Organisation size (H4)	+	0.147*	2.357	Accepted
Total quality management (H5)	+	0.508*	4.053	Accepted
Just in time manufacturing approaches (H6)	+	0.002	0.012	Rejected

* $P < 0.05$; N/A = Not hypothesised/research question

The results summarised in Table 10.2 are presented as follows:

- The results indicate a direct, positive and non-significant impact of both low cost and differentiation strategies on the extent of balanced scorecard usage.
- The results indicate a direct, negative and non-significant impact of centralisation on the extent of balanced scorecard usage.
- A positive significant relationship was found between formalisation and the extent of balanced scorecard usage.
- The results summarised in Table 10.2 indicate a negative, non-significant impact of the operational dimension of perceived environmental uncertainty (PEU) on the extent of balanced scorecard usage. The results also show a positive non-significant impact of regulatory dimension of perceived environmental uncertainty on the extent of balanced scorecard usage. A negative significant relationship was found between raw material dimension of PEU and the extent of balanced scorecard usage.
- The results indicate a direct, positive and non-significant impact of both dimensions of intensity of competition on the extent of balanced scorecard usage.
- Organisation size has a significant impact on the extent of balanced scorecard usage.
- Total quality management has a positive significant impact on the extent of balanced scorecard usage.
- The results indicate a direct, positive, and non-significant impact of the extent of use of just in time manufacturing approaches on the extent of balanced scorecard usage.

10.3 Implications of research findings to knowledge

The findings of this research have two implications to knowledge relating to performance measurement systems in UK manufacturing companies. The first relates to the implications for academics and second relates to the implications for practitioners and managers. These implications are discussed in the following sub-sections.

10.3.1 Implications for academics

Academically, the findings of this study raise important issues and implications for management accounting researchers. From the perspective of the contingency theory literature, the measurement of contingency variables remains controversial (Larcker, 1981). The results of this study indicated that business strategy, organisational structure, perceived environmental uncertainty, and intensity of competition are multidimensional concepts. Thus, researchers employing contingent variables should utilise factor analysis to assess whether the items used can be aggregated into a single or more than one variable. However, the results presented in Chapter 8 support and provide further evidence for the above argument. For instance, the measurement model analysis of the business strategy concept indicated the multidimensionality of this concept, which consists of two dimensions (i.e. low cost and differentiation). This is different from previous studies (e.g. Govindarajan, 1988) that have measured this concept as a simple continuum between firms following a low cost strategy and those following differentiation strategy (Dent, 1990). Such a continuum neglects the multidimensionality of strategy because a single measure is unlikely to capture many relevant strategic distinctions therefore a low score on low cost strategy does not essentially indicate a high score on the differentiation strategy (Ittner and Larcker, 2001).

In addition, the measurement model analysis of the organisational structure concept indicated the multidimensionality of this concept, which consists of two dimensions (i.e. centralisation and formalisation). However, to confirm the importance of these two dimensions, the results of this study indicated a different impact of these dimensions on the extent of both performance measurement diversity usage and balanced scorecard usage. Therefore, these dimensions do not necessarily represent the continuum from organic to mechanistic structure. Thus, researchers should consider organisational structure as a multidimensional concept.

Moreover, the measurement model analysis of the perceived environmental uncertainty concept indicated the multidimensionality of this concept. This result contradicts with the common norm in management accounting research that perceived environmental uncertainty is a unidimensional concept. In contrast, this result is in line with another argument suggested by several researchers (e.g. Tymon et al., 1998) that perceived environmental uncertainty is not unidimensional. Therefore, the multidimensionality of perceived environmental uncertainty resulted in three dimensions (i.e. operational, raw material, and regulatory). However, each dimension was found to have a different impact on other concepts in the research theoretical models. Thus, if this study had neglected the multidimensionality of perceived environmental uncertainty the results may have produced weak relationships between perceived environmental uncertainty and the extent of both performance measurement diversity usage and balanced scorecard usage. Besides, the intensity of competition concept has been usually considered in the contingency theory research (e.g. Gordon and Narayanan, 1984) as one dimension of the perceived environmental uncertainty concept. Other studies (e.g. Hoque et al., 2001; Guilding and McManus, 2002) have considered the intensity of competition concept as a unidimensional concept. However, the results that emerged from the measurement model analysis conducted in this study and discussed in Chapter 8 indicated that intensity of competition is a multidimensional concept rather than unidimensional concept. To validate the multidimensionality of intensity of competition, each dimension was found to have a different impact on other concepts in the research theoretical models.

This study extends previous research concerning the implications and practices of performance measurement systems (e.g. Anderson, 1994; Nagar and Rajan, 2001) by investigating the importance of several financial and non-financial performance categories to long-term organisational success and their use in performance measurement and evaluation purposes, setting strategic goals and the level of quality of these performance measurements. It also extends the research on the contingency approach used in management accounting (e.g. Sim and Killough, 1998; Hoque et al., 2001) through investigating the impact of several contingent variables on the extent of financial and non-financial performance measurements usage. In addition, this study addresses important implication relating to organisational effectiveness and different approaches to fit. It has been argued in Chapter 5 (sub-section 5.4.4) that organisational effectiveness was measured in contingency research by several dimensions. Thus, this study extends previous contingency research by considering two

dimensions of organisational effectiveness (i.e. organisational performance and level of satisfaction). It has also been argued that theoretical and methodological advances are needed to determine which of the many approaches for measuring fit is most appropriate (Ittner and Larcker, 2001, p. 390). The use of two approaches to fit (i.e. bivariate and systems) in this study has produced useful findings (see Chapter 9, sections 9.2 and 9.3). There have also been calls for increased rigor in management accounting research and this research has responded to this by utilising structural equation modelling to assess construct validity.

Most of the previous studies that have examined the extent of balanced scorecard usage have defined the extent of usage in questionable ways. For instance, several studies (e.g. Ittner, Larcker and Randall, 2003) have relied on the respondents self-rating their systems as balanced scorecard users or non-users. Other studies (e.g. Hoque and James, 2000) have relied on the respondents self-rating if their companies are using financial and non-financial performance measures. This study suggests that there is a need for more valid measures of what represents the extent of balanced scorecard usage because there is no reliable statement that can be used to indicate the degree to which this approach has been implemented. Thus, this study provides researchers with detailed steps and procedures for ensuring if the companies are really balanced scorecard users. Adopting this approach in future research has the potential to provide a greater level of confidence in determining the extent of balanced scorecard usage. Also, the study provides future balanced scorecard researchers with a broader conceptualisation of balanced scorecard through the detailed explanation of the components and contents of this approach. Finally, it should be noted that this study is one of the first studies to empirically investigate the impact of several contingent variables on the extent of balanced scorecard usage.

This study has empirically investigated the relationships between several contingent variables and the extent of both balanced scorecard usage and performance measurement diversity usage (financial and non-financial measures). Thus, the study has developed two theoretical models which explain these relationships (an explanation for these two theoretical models is presented in Chapter 5). The results that emerged from testing the research hypotheses for the two theoretical models and discussed in Chapter 9 showed contradictory results. Such results could not have been reached from a sole reliance on previous definitions and measurements of balanced scorecard extent of usage. Therefore, it can be suggested that the definition and measurement of balanced scorecard extent of usage is to some extent different from relying

only on financial and non-financial performance measures even though the latter has been widely used in earlier balanced scorecard studies (e.g. Hoque and James, 2000) as a measure of balanced scorecard extent of usage. Thus, some of the confusion in balanced scorecard findings may be attributable to not acknowledging the way that balanced scorecard should be defined and measured in management accounting studies.

Finally, it should be noted that this study has used two different approaches suggested by Wallace and Mellor (1988) for checking questionnaire non-response bias. The first method was used to compare early and late respondents in terms of business sector, number of employees and annual sales turnover. The second method is to compare the characteristics of respondents with non-respondents from the sample (see Chapter 6 section 6.12). As a result, utilising these two approaches provides increased confidence to suggest that the limitation of a non-response bias may not be applicable in this research, and therefore, researchers may attach greater confidence to generalising the findings.

10.3.2 Implications for managers

The results of this study have some useful practical implications for managers in large UK manufacturing companies. These are summarised as follow:

- Non-financial performance measurements such as operational, quality and customers are the most widely used measures for performance measurement and evaluation purposes. Managers, however, are encouraged to use other performance measurements such as supplier, employee, innovation and environment in order to enhance several stakeholders' needs.
- Managers should consider paying more attention to analysing and linking their performance measurement systems to business strategy in order to increase and enhance their company's ability to achieve the required objectives.
- Managers need to analyse if their non-financial performance measurements are causally linked to each other and also to future financial performance outcomes.
- Managers should consider analysing the external environment in terms of its unpredictability in terms of industrial regulations. In particular, government intervention may lead to the need to place more emphasis on using different types of non-financial performance measures.

- Managers should give increasing emphasis to tracing both financial and non-financial performance of their companies in order to achieve competitive advantage in highly intensive competitive markets.
- Where manufacturing practices such as total quality management and just in time manufacturing approaches are used managers should identify and emphasise an appropriate set of non-financial performance measures in their performance measurement systems. In other words, the increasing use of these non-financial performance measures is higher in companies using these manufacturing practices.
- It can be suggested that internally consistent and concurrent efforts by large UK manufacturing companies to (1) enhance their strategic orientation, (2) formalise their structures, (3) use both total quality management and just in time manufacturing approaches, (4) deal with the unpredictability in regulations and high market competition and (5) use a diversity of financial and non-financial performance measures to provide managers with relevant information have the potential to contribute to higher organisational performance and higher level of satisfaction of performance measurement system.
- There was little consistency between UK manufacturing companies in applying the balanced scorecard approach in their performance measurement systems. This inconsistency includes: type and number of performance perspectives, number of objectives and measures and the level of implementation. However, half of the balanced scorecard companies agreed on the importance of this approach in achieving operational results and organisational benefits. This also was supported through the level of satisfaction from using this approach. Thus, this study provides managers with a better understanding of how balanced scorecards are used in the UK manufacturing companies.
- Finally, this study provides senior managers responsible for the design of performance measurement system with a better understanding of the contextual factors (e.g. internal organisational processes and external factors) that should be considered when designing effective performance measurement system.

10.4 Limitations and further research agenda

As with all management accounting research, this research is subject to a number of limitations and these might be explored in future research. The study adopted the quantitative approach to test the research theoretical models, thus limiting the choice of methodology to a

cross-sectional survey, which is only concerned with employing quantitative methods of data collection. Thus, a postal questionnaire survey was adopted in this research and the researcher was not able to question the respondents to ascertain in more details the exact nature of the responses. Therefore, extra care and caution is essential when interpreting questionnaire findings. However, the problems relating to postal questionnaire surveys can be minimised by undertaking a number of post-questionnaire interviews. However, a time constraint, interview accessibility, the availability of interviewees for a significant amount of time and transportation difficulties constrains overseas PhD researchers from undertaking interviews. Nevertheless, interviews to pursue issues raised by the survey results (see below for a further discussion) is a fruitful area for future research.

In addition, the results of this study apply only to large manufacturing companies operating in the UK. Thus, these results may not be generalisable to small manufacturing companies or to other companies operating in other industrial sectors such as the service sector. Future research however needs to be extended to other industry sectors in order to generalise the results. It has also been argued in the management accounting literature (e.g. Drury, 2004) that the use of management accounting techniques generally do not differ across countries. Therefore, an interesting area of research would be to examine if this assertion is true by examining the application of the balanced scorecard approach in other countries.

It has been argued that all multivariate data analysis approaches (e.g. structural equation modelling and multiple regression) do actually signify causality between the independent and dependent variables (e.g. Hoyle, 1995). Despite the advantages of using these approaches, the causal relationships between variables should be treated with caution due to the cross-sectional methodology of this study. Thus, it may be preferable not to draw any fixed conclusions about the directions of relationships being applicable to specific individual companies, because in reality, multivariate data analysis does nothing more than test the relations among the aggregation of the variables as they were assessed. Therefore, these methods cannot overcome the limitations associated with non-experimental data gathered in a single session (Hoyle, 1995).

With respect to management accounting research, much of the research on the balanced scorecard has focused on explaining how and why the balanced scorecard should be adopted as part of management accounting innovation research. However, this study has not taken

into consideration the motives for implementing balanced scorecard approach, and the extent to which other accounting innovations are associated with the adoption of balanced scorecard approach. In contrast, this study is one of the first on the extent of balanced scorecard implementation stages. As a result, this study has not focused in depth on how companies are actually using the balanced scorecard approach. For example, the results that have emerged from this study have indicated inconsistency between balanced scorecard companies in the way this approach was used. In addition, little attention was given in this study to examining how the balanced scorecard companies are dealing with the main assumptions of this approach (i.e. linking measures to strategy and cause-and-effect relationships).

Thus, to obtain a more complete picture, attention should be focused on using more in depth case studies to provide a greater understanding of how and why these companies are dealing with this approach and its assumptions. It has also been argued in Chapter 3 that Kaplan and Norton have suggested several steps for designing a balanced scorecard in companies. Thus, case studies may be conducted to examine if the balanced scorecard companies have designed their balanced scorecard based on Kaplan and Norton's designing steps. Also, case studies should be conducted to explain why some companies have not seriously considered if the balanced scorecard would be appropriate. For those companies that have implemented the balanced scorecard and then rejected it, interviews to identify the factors leading to rejection would be of interest. Future research using case studies that seeks to identify and explain the perceived deficiencies of the balanced scorecard would also be appropriate.

It has been indicated in Chapter 1 that there are many alternative management accounting research approaches and this research has adopted the contingency theory approach. Therefore, future balanced scorecard research would be enhanced by incorporating theories derived from social science, particularly those that involve studying balanced scorecard adoption within the management accounting change process. Such research may involve the use of longitudinal case studies drawing off a wide range of theoretical frameworks including social theory. For example, the institutional framework² presented by Burns and Scapens (2000) might be used to understand the problems that may occur during the introduction and

² Burns and Scapens (2000) describe an institutional framework that might be used for the conceptualization of management accounting change. They have argued that management accounting practices constitute organizational rules and routines. These rules and routines are an integral part of the relationship between action and institution in the organization. In the context of management accounting, rules comprise the accounting systems as set out in the procedure manuals, whereas routines are the management accounting practices actually in use (Burns et al., 2003, p. 18).

implementation process of the balanced scorecard approach. Further longitudinal case studies may also concentrate on the influencing forces (i.e. barriers and advanced forces of change) of implementing the balanced scorecard as a management accounting change.

Based on the experiences of Kaplan and Norton, the balanced scorecard approach is most successful when it used to drive the process of change. Therefore, case studies may be conducted in organisations which have successfully implemented the balanced scorecard approach to ascertain the factors and implementation approaches which have made this successful change (i.e. the balanced scorecard approach) possible. In the same vein, Burns et al. (2003) have argued that the implementation of management accounting change involves important behavioural and cultural issues. Thus, further case studies could explain how employees understand the nature and significance of the balanced scorecard, and does the balanced scorecard approach fit the established rules and routines in the organisation. Such case studies could also focus on the nature and forms of resistance to balanced scorecard implementation in individual organisations.

This study also contributes to management accounting literature by adopting the contingency theory theoretical framework to examine the potential exploratory factors that may influence the extent of balanced scorecard usage. In terms of applying this framework the extent of balanced scorecard usage has been measured in the previous literature by two discrete methods, either a self-rating question (i.e. dichotomous) to measure the implementation stages, or the extent of usage of financial and non-financial performance measures. Such measures do not adequately capture the extent of balanced scorecard usage in performance measurements and evaluation. Similarly, the balanced scorecard approach can also vary in usage between companies (see Chapter 7, section 7.5). Because of such diversity, this study has developed a measure for the extent of balanced scorecard usage by depending on the above methods of measuring the balanced scorecard extent of usage (see Chapters 5 and 8 for explanation). Thus, future research adopting a contingency approach should consider validating the balanced scorecard extent of usage measure used in this study. Other research may also consider developing alternative measures of the extent of balanced scorecard usage.

With regards to the four stages of the contingency theory theoretical framework (discussed in Chapter 4), this study has not incorporated organisational effectiveness in the second research theoretical model (see Chapter 5, sub-section 5.2.2) to assess whether the fit

between the identified contingent variables and balanced scorecard extent of usage has any effect on organisational effectiveness. Thus, future research may assess the effectiveness from applying the balanced scorecard. Another interesting research issue is to determine the situation where subjective measures (e.g. perceived benefits or the level of satisfaction) and objective measures (e.g. financial performance) of effectiveness of the extent of balanced scorecard usage would provide similar or conflicting results. In addition, future research involving longitudinal studies to examine the improvement in performance within companies before and after the implementation of balanced scorecard is also considered to be appropriate.

In addition to the above limitations, most of the remaining limitations relate to the application of the contingency theory theoretical framework (see Chapter 4, section 4.5 for a review of these limitations). These limitations are not confined to this study since they also apply to other contingency theory studies. In terms of this study, several limitations were identified. First, this study has only examined one control system attribute (i.e. performance measurement systems). Thus it has neglected other control systems. In this vein, Fisher (1995) argued that one of the major weaknesses of contingency control research is that it examines only one contingent variable and one control attribute at a time. Second, this study has neglected the indirect relationships 'interaction' between the contingent variables and their simultaneous effect on both the extent of performance measurement diversity usage and the extent of balanced scorecard usage. For example, intensity of market competition might have a direct and indirect influence on the choice of business strategy, organisational structure and the extent of performance measurement diversity usage. Therefore, the extent of both performance measurement diversity usage and balanced scorecard usage may be influenced by the indirect effects (i.e. interaction) between the contingent variables. Third, although contingent variables were identified based on the literature review (see Chapters 4 and 5) and the extent of both performance measurement diversity usage and balanced scorecard usage were examined, a potential limitation in this study relates to the level of variance explained by the contingent variables (see Chapter 9 for a detailed discussion on the values of R^2 which show how much variance the suggested models explain of the dependent variables). The results of the analytical statistics presented and discussed in Chapter 9 suggest that the presence of the contingent variables incorporated in the research theoretical models do not provide a complete explanation of the results. Omitted variables are also likely to influence the results.

Therefore, there is an opportunity for future research to identify and examine the impact of other contingent variables (e.g. culture, management style). Such research could also consider the interaction between these contingent variables and other dimensions of management control system. Moreover, future research could also extend this study by investigating a broader set of performance measurement system attributes that have not been included in this study. Examples include the level of aggregation, integration and timelines that other studies have found to be determinants of the perceived usefulness of performance measurement systems (e.g. Chenhall and Morris, 1986).

10.5 Conclusion

Despite the limitations that have been identified in the previous section, this research has provided several important insights into issues relating to performance measurement system and the balanced scorecard approach. This research is one of the first to investigate how UK manufacturing companies are dealing with the balanced scorecard approach. Also, this study is one of the first to examine the impact of several contingent variables on the extent of balanced scorecard usage. It also contributes to the management accounting literature by providing some guidance for future balanced scorecard research. Hopefully, this research will encourage management accounting researchers to conduct further empirical studies about the balanced scorecard approach to clarify some of the complexity and confusion that is accompanied with this approach. Through this research, both researchers and managers will be better able to understand how the balanced scorecard approach is effectively implemented.

References

- AAA. (1971) "Report of the committee on non-financial measures of effectiveness", *The Accounting Review*, Vol. 46, No. 4, pp. 165-211.
- AAA. (1975) "Report of the committee on non-financial measures of effectiveness", *American Accounting Association*, Sarasota, Flo.
- Abernethy, M. and Lillis, A. (1995) "The impact of manufacturing flexibility on management control system design", *Accounting, Organizations and Society*, Vol. 20, No. 4, pp. 241-258.
- Abran, A. and Buglione, L. (2003) "A multidimensional performance model for consolidating balanced scorecards", *Advances in Engineering Software*, Vol. 34, No. 6, pp. 339-349.
- Agarwal, S. (1999) "Impact of job formalization and administrative controls on attitudes of industrial salespersons", *Industrial Marketing Management*, Vol. 28, No. 4, pp. 359-368.
- Ahn, H. (2001) "Applying the balanced scorecard concept: An experience report", *Long Range Planning*, Vol. 34, No. 4, pp. 441-461.
- Al-Dahiyat, M. (2003) "Towards an effective design of management control systems: A contingency approach", Unpublished PhD Thesis (University of Huddersfield).
- Al-Omiri, M. (2003) "The diffusion of management accounting innovations: A study of the factors influencing the adoption, implementation levels and success of ABC", Unpublished PhD Thesis (University of Huddersfield).
- Amaratunga, D. and Baldry, D. (2003) "A conceptual framework to measure facilities management performance", *Property Management*, Vol. 21, No. 2, pp. 171-189.
- Amaratunga, D., Baldry, D. and Sarshar, M. (2001) "Process improvement through performance measurement: the balanced scorecard methodology", *Work Study*, Vol. 50, No. 5, pp. 179-188.
- Amaratunga, D., Baldry, D., Sarshar, M. and Newton, R. (2002) "Quantitative and qualitative research in the built environment: application of mixed research approach", *Work Study*, Vol. 51, No. 1, pp.1-19.
- Amir, E. and Lev, B. (1996) "Value-relevance of non-financial information: The wireless communications industry", *Journal of Accounting and Economics*, Vol. 22, No. 1-3, pp. 3-30.
- Anderson, E., Fornell, C. and Lehmann, D. (1994) "Customer satisfaction, market share, and profitability: Findings from Sweden", *Journal of Marketing*, Vol. 58, No. 3, pp. 53-66.
- Anderson, S. and Lanen, W. (1999) "Economic transition, strategy and the evolution of management accounting practices: the case of India", *Accounting, Organizations and Society*, Vol. 24, No. 5-6, pp. 379-412.

Anonymous (2001) "Balanced scorecard is fast becoming a must have process for corporate change", *Management Services*, Vol. 45, No. 8, pp. 5-6.

Anthony, R. (1965) "*Management planning and control systems: A framework for research*" (Boston, MA: Harvard Graduate School of Business).

Anthony, R. and Govindarajan, V. (2001) "*Management control systems*", 10th edition (Boston: McGraw-Hill).

Anthony, R., Dearden, J. and Bedford, N. (1989) "*Management control systems*", 6th edition (Homewood, III: Irwin).

Atkinson, A., Balakrishnan, R., Booth, P., Cote, J., Groot, T., Malmi, T., Roberts, H., Uliana, E. and Wu, A. (1997) "New directions in management accounting research", *Journal of Management Accounting Research*, Vol. 9, pp. 79-109.

Atkinson, A., Waterhouse, J. and Wells, R. (1997) "A stakeholder approach to strategic performance measurement", *Sloan Management Review*, Vol. 38, No. 3, pp. 25-37.

Ax, C. and Bjornenak, T. (2005) "Bundling and diffusion of management accounting innovations-the case of the balanced scorecard in Sweden", *Management Accounting Research*, Vol. 16, No. 1, pp. 1-20.

Azofra, V., Prieto, B. and Santidrian, A. (2002) "The use of performance measures for knowledge management: a case study", The 25th Annual Congress of the European Accounting Association (Copenhagen-Denmark).

Baber, W., Daniel, P. and Roberts, A. (2002) "Compensation to managers of charitable organisations: An empirical study of the role of accounting measures of program activities", *The Accounting Review*, Vol. 77, No. 3, pp. 679-693.

Bagozzi, R. and Heatherton, T. (1994) "A general approach to representing multifaceted personality constructs: application to state self-esteem", *Structural Equation Modeling*, Vol. 1, pp. 35-67.

Bailey, A. Chow, C. and Haddad, K. (1999) "Continuous improvement in business education: Insights from the for-profit sector and business school Deans", *Journal of Education for Business*, Vol. 74, No. 3, pp. 165-181.

Baines, A. and Langfield-Smith, K. (2003) "Antecedents to management accounting change: a structural equation approach", *Accounting, Organizations and Society*, Vol. 28, No. 7-8, pp. 675-698.

Balanced Scorecard Collaborative. (2000) "About the balanced scorecard", Balanced Scorecard Collaborative Website (<http://www.bscol.com>).

Banerjee, J. and Kane, W. (1996) "Informing the accountant", *Management Accounting (UK)*, Vol. 74, No. 9, pp. 30-37.

- Banker, R., Chang, H., Janakiraman, S. and Konstans, C. (2004) "A balanced scorecard analysis of performance metrics", *European Journal of Operational Research*, Vol. 154, No. 2, pp. 423-436.
- Banker, R., Janakiraman, S. and Konstans, C. (2001) "Balanced scorecard: linking strategy to performance", FEI, Research Foundation.
- Banker, R., Potter, G. and Schroeder, R. (1993) "Reporting manufacturing performance measures to workers: An empirical study", *Journal of Management Accounting Research*, Vol. 5, Fall, pp. 34-55.
- Banker, R. Potter, G. and Srinivasan, D. (2000) "An empirical investigation of an incentive plan that includes non-financial performance measures", *The Accounting Review*, Vol. 75, No. 1, pp. 65-92.
- Baumgartner, H. and Homburg, C. (1996) "Applications of structural equation modeling in marketing and consumer research: A review", *International Journal of Research in Marketing*, Vol. 13, No. 2, pp. 139-161.
- Bentler, P. (1995) "*EQS Structural Equations Program Manual*", (Encino, CA: Multivariate Software, Inc.).
- Bentler, P. and Chou, C. (1987) "Practical issues in structural modeling", *Sociological Methods and Research*, Vol. 16, pp. 78-117.
- Bergeron, F., Raymond, L. and Rivard, S. (2001) "Fit in strategic information technology management research: an empirical comparison of perspectives", *The International Journal of Management Science*, Vol. 29, pp. 125-142.
- Bhimani, A. (1994) "Monitoring performance measures in UK manufacturing companies", *Management Accounting (UK)*, Vol. 72, No. 1, pp. 34-37.
- Bierman, H. (1988) "Extending the usefulness of accrual accounting", *Accounting Horizons*, Vol. 2, No. 3, pp. 10-14.
- Bisbe, J. and Otley, D. (2004) "The effects of the interactive use of management control systems on product innovation", *Accounting, Organizations and Society*, Vol. 29, No. 8, pp. 709-737.
- Bititci, U., Nudurupati, S., Turner, T. and Creighton, S. (2002) "Web enabled performance measurement systems", *International Journal of Operations & Production Management*, Vol. 22, No.11, pp. 1273-1287.
- Bjornenak, T. (1997) "Diffusion and accounting: the case of ABC in Norway", *Management Accounting Research*, Vol. 8, No. 1, pp. 3-17.
- Booth, R. (1997) "Performance management: making it happen", *Management Accounting (UK)*, Vol. 75, No. 10, pp. 28-30.

Bourguignon, A., Malleret, V. and Norreklit, H. (2004) "The American balanced scorecard versus the French tableau de bord: the ideological dimension", *Management Accounting Research*, Vol. 15, No. 2, pp. 107-134.

Bourne, M., Mills, J., Wilcox, M., Neely, A. and Platts, K. (2000) "Designing, implementing and updating performance measurement systems", *International Journal of Operations & Production Management*, Vol. 20, No.7, pp. 754-771.

Bourne, M., Neely, A., Platts, K. and Mills, J. (2002) "The success and failure of performance measurement initiatives: Perceptions of participating managers", *International Journal of Operations & Production Management*, Vol. 22, No.11, pp. 1288-1310.

Braam, G. and Nijssen, E. (2004a) "Exploring determinants of balanced scorecard adoption", The 27th Annual Congress of the European Accounting Association (Prague-Czech Republic).

Braam, G. and Nijssen, E. (2004b) "Performance effects of using the balanced scorecard: a note on the Dutch experience", *Long Range Planning*, Vol. 37, No. 4, pp. 335-349.

Braam, G., Heusinkveld, S., Benders, J. and Aubel, A. (2002) "The reception pattern of the balanced scorecard: Accounting for interpretative viability", The 25th Annual Congress of the European Accounting Association (Copenhagen-Denmark).

Bremser, W. and White, L. (2000) "An experiential approach to learning about the balanced scorecard", *Journal of Accounting Education*, Vol. 18, No. 3, pp. 241-255.

Brignall, S. (1997) "A contingent rationale for cost system design in services", *Management Accounting Research*, Vol. 8, No. 3, pp. 325-346.

Bromwich, M. and Bhimani, A. (1989) "Management Accounting: Evolution not Revolution", *CIMA*, London.

Bromwich, M. and Bhimani, A. (1994) "Management accounting pathways to progress", *CIMA*, London.

Bromwich, M. and Walker, M. (1998) "Residual income past and future", *Management Accounting Research*, Vol. 9, No. 4, pp. 391-419.

Browne, J. and Devlin, J. (2002) "Performance measurement: The ENAPS approach", The 25th Annual Congress of the European Accounting Association (Copenhagen-Denmark).

Bruns, W. and Waterhouse, J. (1975) "Budgetary control and organizational structure", pp. 115-138, in R. Chenhall, G. Harrison and D. Watson (eds.) (1981) *The Organizational Context of Management Accounting* (Boston: Pitman).

Bryman, A. and Cramer, D. (2001) *Quantitative Data Analysis with SPSS Release 10 for Windows*, (Routledge).

Burchell, S., Clubb, C., Hopwood, A., Hughes, J. and Nahapiet, J. (1980) "The roles of accounting in organizations and society", *Accounting, Organizations and Society*, Vol. 5, No. 1, pp. 5-27.

Burns, J. and Scapens, R. (2000) "Conceptualizing management accounting change: an institutional framework", *Management Accounting Research*, Vol. 11, No. 1, pp. 3-25.

Burns, J. and Vaivio, J. (2001) "Management accounting change", *Management Accounting Research*, Vol. 12, No. 4, pp. 389-402.

Burns, J. and Yazdifar, H. (2001) "Trick or treats", *Financial Management*, March, pp. 33-35.

Burns, J., Ezzamel, M. and Scapens, R. (2003) "The challenge of management accounting change: Behavioural and cultural aspects of change management", CIMA/Elsevier publishing.

Burns, T. and Stalker, G. (1961) *The Management of Innovation*, (London: Tavistock).

Butler, A., Letza, S. and Neale, B. (1997) "Linking the balanced scorecard to strategy", *Long Range Planning*, Vol. 30, No. 2, pp. 242-253.

Byrne, B. (1995) "One application of structural equation modeling from two perspectives: Exploring the EQS and LISREL strategies", pp. 138-157, in R. Hoyle (ed.) *Structural Equation Modeling: Concepts, Issues and Applications* (Thousand Oaks, CA: Sage).

Cagwin, D. and Bouwman, M. (2002) "The association between activity-based costing and improvement in financial performance", *Management Accounting Research*, Vol.13, No. 1, pp. 1-39.

Cauvin, E. and Bescos, P. (2002) "Performance measurement practices: Comparing French start-ups to French and American traditional firms", The 25th Annual Congress of the European Accounting Association (Copenhagen-Denmark).

Chang, L., Lin, S. and Northcott, D. (2002) "Preliminary analysis of the cause and effect relationship within the NHS "Balanced Scorecard" performance measurement system", The 25th Annual Congress of the European Accounting Association (Copenhagen-Denmark).

Chapman, C. (1997) "Reflections on a contingent view of accounting", *Accounting, Organizations and Society*, Vol. 22, No. 2, pp. 189-205.

Chau, P. (1997) "Reexamining a model for evaluating information center success using a structural equation modeling approach", *Decision Sciences*, Vol. 28, No. 2, pp. 309-333.

Chenhall, R. (1997) "Reliance on manufacturing performance measures, total quality management and organisational performance", *Management Accounting Research*, Vol. 8, No. 2, pp. 187-206.

Chenhall, R. (2003) "Management control systems design within its organizational context: findings from contingency-based research and directions for the future", *Accounting, Organizations and Society*, Vol. 28, No. 2/3, pp. 127-168.

Chenhall, R. (2005) "Integrative strategic performance measurement systems, strategic alignment of manufacturing, learning and strategic outcomes: an exploratory study", *Accounting, Organizations and Society*, Vol. 30, No. 5, pp. 395-422.

Chenhall, R. and Langfield-Smith, K. (1998a) "Adoption and benefits of management accounting practices: an Australian study", *Management Accounting Research*, Vol. 9, No. 1, pp. 1-19.

Chenhall, R. and Langfield-Smith, K. (1998b) "The relationship between strategic priorities, management techniques and management accounting: an empirical investigation using a systems approach", *Accounting, Organizations and Society*, Vol. 23, No. 3, pp. 243-264.

Chenhall, R. and Morris, D. (1986) "The impact of structure, environment and interdependence on perceived usefulness of management accounting systems", *The Accounting Review*, Vol. 61, No. 1, pp. 16-35.

Chia, Y. (1995) "Decentralization, management accounting system (MAS) information characteristics and their interaction effects on managerial performance: A Singapore study", *Journal of Business Finance and Accounting*, Vol. 22, No. 6, pp. 811-830.

Chou, C. and Bentler, P. (1995) "Estimates and tests in structural equation modeling", pp. 37-55, in R. Hoyle (ed.) *Structural Equation Modeling: Concepts, Issues and Applications* (Thousand Oaks, CA: Sage).

Chow, C., Haddad, K. and Williamson, J. (1997) "Applying the balanced scorecard to small companies", *Management Accounting (USA)*, Vol. 79, No. 2, pp. 21-27.

CIMA. (1993) "Performance measurement in the manufacturing sector", *Chartered Institute of Management Accountants*, London.

Clarke, P. and Tyler, F. (2002) "Implementing a balanced scorecard: An Irish example", *Journal of the Irish Academy of Management*, pp. 137-155.

Clinton, B. and Hsu, K. (1997) "JIT and the balanced scorecard: Linking manufacturing control to management control", *Management Accounting (USA)*, Vol. 79, No. 3, pp. 18-24.

Coates, J., Davis, E., Longden, S., Stacey, R. and Emmanuel, C. (1993) "Corporate Performance Evaluation in Multinationals", *CIMA*, London.

Cohen, J. (1988) *Statistical power analysis for the behavioural sciences*, 2nd edition (New Jersey: Hillsdale, Erlbaum).

Cohen, J. and Holliday, M. (1982) *Statistics power for social sciences*, (London: Harper & Row).

Cooper, D. and Ezzamel, M. (2004) "A social analysis of the assumptions of the balanced scorecard: Towards a more integrated strategic performance measurement system", The 27th Annual Congress of the European Accounting Association (Prague-Czech Republic).

Cooper, D. and Schindler, P. (2001) "*Business Research Methods*", 7th edition, (New York: Irwin/McGraw-Hill).

Creswell, J. (1994) "*Research Design: Quantitative and Qualitative Approaches*", (Thousand Oaks, CA, Sage).

Creswell, J. (2003) "*Research design-qualitative, quantitative, and mixed methods and approaches*", 2nd edition, (Thousand Oaks, Sage Publications, California).

Crowley, S. and Fan, X. (1997) "Structural equation modeling: Basic concepts and applications in personality assessment research", *Journal of Personality Assessment*, Vol. 68, No. 3, pp. 508-531.

Cumby, J. and Conrod, J. (2001) "Non-financial performance measures in the Canadian biotechnology industry", *Journal of Intellectual Capital*, Vol. 2, No. 3, pp. 261-272.

Daft, R. (1992) "*Organization Theory and Design*", 4th edition, (West).

Daft, R. and Macintosh, N. (1978) "A new approach to design and use of management information", *California Management Review*, Vol. 21, No. 1, pp. 82-92.

Dale, B., Cooper, C. and Wilkinson, A. (1997) "*Managing quality and human resources, a guide to continuous improvement*", (Blackwell Publishers Ltd).

Dalton, D., Todor, W., Spendolini, M., Fielding, G. and Porter, L. (1980) "Organization structure and performance: A critical review", *Academy of Management Review*, Vol. 5, No. 1, pp. 49-64.

Damanpour, F. (1991) "Organizational innovation: a meta-analysis of effects of determinants and moderators", *Academy of Management Journal*, Vol. 34, No. 3, pp. 555-590.

Davis, S. and Albright, T. (2004) "An investigation of the effect of balanced scorecard implementation on financial performance", *Management Accounting Research*, Vol. 15, No. 2, pp. 135-153.

De Toni, A. and Tonchia, S. (2001) "Performance measurement systems: Models, characteristics and measures", *International Journal of Operations & Production Management*, Vol. 21, No. 1/2, pp. 46-70.

De Waal, A. (2003) "Behavioural factors important for the successful implementation and use of performance management systems", *Management Decision*, Vol. 41, No. 8, pp. 688-697.

DeBusk, G., Brown, R. and Killough, L. (2003) "Components and relative weights in utilization of dashboard measurement systems like the balanced scorecard", *British Accounting Review*, Vol. 35, No. 3, pp. 215-231.

Dent, J. (1990) "Strategy, organization and control: Some possibilities for accounting research", *Accounting, Organizations and Society*, Vol. 15, No. 1/2, pp. 3-25.

Drucker, P. (1964) "Control, controls and management", in C. Bonini, R. Jaedicke, and H. Wagner (eds.) *Management Controls: New Directions in Basic Research* (New York: McGraw-Hill).

Drucker, P. (1990) "The emerging theory of manufacturing", *Harvard Business Review*, Vol. 68, No. 3, pp. 94-102.

Drury, C. (2004) *Management and Cost Accounting*, 6th edition (London: Thomson).

Drury, C. (2002) *Management and Cost Accounting*, 5th edition (London: Thomson).

Drury, C. (1997) *Management accounting for business decisions*, (London: Thomson).

Drury, C., Braund, S., Osborne, P. and Tayles, M. (1993) "A survey of management accounting practices in UK manufacturing companies", *ACCA Research Occasional Paper*, Chartered Association of Certified Accountants.

Dumond, E. (1994) "Making best use of performance measures and information", *International Journal of Operations & Production Management*, Vol.14, No. 9, pp. 16-31.

Duncan, R. (1972) "Characteristics of organizational environments and perceived environmental uncertainty", *Administrative Science Quarterly*, Vol. 17, No. 3, pp. 313-327.

Dunk, A. (2003) "Financial and non-financial performance: The influence of quality of information, corporate environmental integration, product innovation, and product quality", The 26th Annual Congress of the European Accounting Association (Sevilla-Spain).

Dunn, G., Everitt, B. and Pickles, A. (1994) *Modelling Covariances and Latent Variables using EQS*, (Chapman & Hall, London).

Easterby-Smith, M., Thorpe, R. and Lowe, A. (2002) *Management research*, 2nd edition, (California: Sage Publications).

Eccles, R. (1991) "The performance measurement manifesto", *Harvard Business Review*, Vol. 69, No. 1, pp. 131-137.

Edvinsson, L. and Malone, M. (1997) *Intellectual capital: realizing your companies true value by finding its hidden brain power*, (New York: Harper Business).

Elmore, P. and Beggs, D. (1975) "Salience of concepts and commitment to extreme judgements in response pattern of teachers", *Education*, Vol. 95, No. 4, pp. 325-334.

Epstein, M. and Manzoni, J. (1997) "The balanced scorecard and tableaux de bord: Translating strategy into action", *Management Accounting (USA)*, Vol. 79, No. 2, pp. 28-36.

Epstein, M. and Manzoni, J. (1998) "Implementing corporate strategy: From tableaux de bord to balanced scorecards", *European Management Journal*, Vol. 16, No. 2, pp. 190-203.

Euske, K., Lebas, M. and McNair, C. (1993) "Performance management in an international setting", *Management Accounting Research*, Vol. 4, No. 4, pp. 275-299.

- Ezzamel, M. (1990) "The impact of environmental uncertainty, managerial autonomy and size on budget characteristics", *Management Accounting Research*, Vol. 1, No. 2, pp. 181-197.
- Ezzamel, M., Lilley, S. and Willmott, H. (1993) "Changes in management practices in UK companies", *CIMA Research Report*, London.
- Ezzamel, M., Lilley, S. and Willmott, H. (1996) "The view from the top: senior executives' perceptions of changing management practices in UK companies", *British Journal of Management*, Vol. 7, No. 2, pp. 155-168.
- Field, A. (2000) "*Discovering Statistics using SPSS for Windows-Advanced Techniques for the Beginner*", (London: Sage Publications).
- Fisher, J. (1995a) "Use of non-financial performance measures", in Young, S. (Ed), *Management Accounting*, Prentice Hall, Englewood Cliffs, NJ, pp. 329-335.
- Fisher, J. (1995b) "Contingency-based research on management control systems: Categorisation by level of complexity", *Journal of Accounting Literature*, Vol. 14, pp. 24-53.
- Fisher, J. (1998) "Contingency theory, management control systems and firm outcomes: Past results and future directions", *Behavioural Research in Accounting*, Vol. 10, pp. 47-64.
- Fitzgerald, L., Johnston, R., Brignall, S., Silvestro, R. and Voss, C. (1991) "Performance measurement in service business", *CIMA*, London.
- Foster, G. and Young, S. (1997) "Frontiers of management accounting research", *Journal of Management Accounting Research*, Vol. 9, pp. 63-77.
- Francis, G. and Minchington, C. (2000) "Value-based management in practice", *Management Accounting (UK)*, Vol. 78, No. 2, pp. 46-47.
- Frigo, M. and Krumwiede, K. (1999) "Balanced scorecards: A rising trend in strategic performance measurement", *Journal of Strategic Performance Measurement*, Februray/March, pp. 42-48.
- Frigo, M. and Krumwiede, K. (2000) "The balanced scorecard: a winning performance measurement system", *Management Accounting (USA)*, Vol. 81, No. 7, pp. 50-54.
- Fullerton, R. and McWatters, C. (2002) "The role of performance measures and incentive systems in relation to the degree of JIT implementation", *Accounting, Organizations and Society*, Vol. 27, No. 8, pp. 711-735.
- Garver, M. and Mentzer, J. (1999) "Logistics research methods: Employing structural equation modeling to test for construct validity", *Journal of Business Logistics*, Vol. 20, No. 1, pp. 33- 47.
- Gautreau, A. and Kleiner, B. (2001) "Recent trends in performance measurement systems-the balanced scorecard approach", *Management Research News*, Vol. 24, No. 3/4, pp. 153-156.

Gehrke, I. and Horvath, P. (2002) "Implementation of performance measurement: a comparative study of French and German organizations", in M. Epstein, and J. Manzoni (Eds.) *Performance Measurement and Management Control: A Compendium of Research, Studies in Financial and Management Accounting*, Vol. 9, JAI Press, London, pp. 159-180.

Gerdin, J. and Greve, J. (2004) "Forms of contingency fit in management accounting research-a critical review", *Accounting, Organizations and Society*, Vol. 29, No. 3/4, pp. 303-326.

Ghalayini, A. and Noble, J. (1996) "The changing basis of performance measurement", *International Journal of Operations & Production Management*, Vol.16, No. 8, pp. 63-80.

Giannetti, R., Marelli, A. and Vitali, P. (2002) "A survey on non financial measure practices in Italian management accounting systems", The 25th Annual Congress of the European Accounting Association (Copenhagen-Denmark).

Globerson, S. (1985) "Issues in developing performance criteria system for an organisation", *International Journal of Production Research*, Vol. 23, No. 4, pp. 639-646.

Gordon, L. and Miller, D. (1976) "A contingency framework for the design of accounting information systems", *Accounting, Organizations and Society*, Vol. 1, No. 1, pp. 59-69.

Gordon, L. and Narayanan, V. (1984) "Management accounting systems, perceived environmental uncertainty and organization structure: An empirical investigation", *Accounting, Organizations and Society*, Vol. 9, No. 1, pp. 33-47.

Gosselin, L. (1997) "The effects of strategy and organizational structure on the adoption and implementation of activity-based costing", *Accounting, Organizations and Society*, Vol. 22, No. 2, pp. 105-122.

Govindarajan, V. (1984) "Appropriateness of accounting data in performance evaluation: An empirical examination of environmental uncertainty as an intervening variable", *Accounting, Organizations and Society*, Vol. 9, No. 2, pp. 125-135.

Govindarajan, V. (1988) "A contingency approach to strategy implementation at the business-unit level: Integrating administrative mechanisms with strategy", *Academy of Management Journal*, Vol. 31, No. 4, pp. 828-853.

Govindarajan, V. and Fisher, J. (1990) "Strategy, control systems and resource sharing: Effects on business unit performance", *Academy of Management Journal*, Vol. 33, No. 2, pp. 259-285.

Govindarajan, V. and Gupta, A. (1985) "Linking control systems to business unit strategy: impact on performance", *Accounting, Organizations and Society*, Vol. 10, No. 1, pp. 51-66.

Guenther, T. and Gruening, M. (2002) "Measuring performance: A cross-sectional empirical survey", The 25th Annual Congress of the European Accounting Association (Copenhagen-Denmark).

- Guilding, C. (1999) "Competitor-focused accounting: an exploratory note", *Accounting, Organizations and Society*, Vol. 24, No. 7, pp. 583-595.
- Guilding, C. and McManus, L. (2002) "The incidence, perceived merit and antecedents of customer accounting: an exploratory", *Accounting, Organizations and Society*, Vol. 27, No. 1/2, pp. 45-59.
- Gul, F. (1991) "The effects of management accounting systems and environmental uncertainty and decentralization on managerial performance", *Accounting and Business Research*, Vol. 21, No. 85, pp. 57-61.
- Gul, F. and Chia, Y. (1994) "The effects of management accounting systems, perceived environmental uncertainty and decentralization on managerial performance: A test of three-way interaction", *Accounting, Organizations and Society*, Vol. 19, No. 4/5, pp. 413-426.
- Gupta, A. (1987) "SBU strategies, corporate-SBU, and SBU effectiveness in strategy implementation", *Academy of Management Journal*, Vol. 30, No. 3, pp. 477-500.
- Hair, J., Anderson, R., Tatham, R. and Black, W. (1998) "*Multivariate Data Analysis*", 5th edition, (Upper Saddle River, NJ: Prentice-Hall).
- Hair, J., Babin, B., Money, A. and Samouel, P. (2003) "*Essentials of Business Research Methods*", (John Wiley & Sons, Inc.).
- Hayes, D. (1977) "The contingency theory of managerial accounting", *The Accounting Review*, Vol. 52, No. 1, pp. 22-39.
- Hepworth, P. (1998) "Weighing it up-a literature review for the balanced scorecard", *Journal of Management Development*, Vol. 17, No. 7/8, pp. 559-563.
- Hirst, M. (1981) "Accounting information and the evaluation of subordinate performance: A situational approach", *The Accounting Review*, Vol. 56, No. 4, pp. 771-784.
- Hopwood, A. (1972) "An empirical study of the role of accounting data in performance evaluation", *Journal of Accounting Research*, Vol. 10, No. 3, pp. 156-182.
- Hopwood, A. (1976) "*Accounting and Human Behavior*", (Englewood Cliffs, NJ: Prentice-Hall).
- Hoque, Z. (2003) "Total quality management and the balanced scorecard approach: A critical analysis of their potential relationships and directions for research", *Critical Perspectives on Accounting*, Vol. 14, No. 5, pp. 553-566.
- Hoque, Z. and James, W. (2000) "Linking balanced scorecard measures to size and market factors: Impact on organizational performance", *Journal of Management Accounting Research*, Vol. 12, pp. 1-17.
- Hoque, Z., Mia, L. and Alam, M. (2001) "Market competition, computer-aided manufacturing and use of multiple performance measures: An empirical study", *British Accounting Review*, Vol. 33, No. 1, pp. 23-45.

Horngrén, C. (1995) "Management accounting this century and beyond", *Management Accounting Research*, Vol. 6, No. 3, pp. 281-286.

Hoyle, R. (1995) "The structural equation modeling approach, basic concepts and fundamental issues", pp. 1-15, in R. Hoyle (ed.) *Structural Equation Modeling: Concepts, Issues and Applications* (Thousand Oaks, CA: Sage).

Hughes, A. and Halsall, D. (2002) "Comparison of the 14 deadly diseases and the business excellence model", *Total Quality Management*, Vol.13, No. 2, pp. 255-263.

Hughes, K. (2000) "The value relevance of non-financial measures of air pollution in the electric utility industry", *The Accounting Review*, Vol. 75, No. 2, pp. 209-228.

Hussain, M. and Gunasekaran, A. (2002) "An institutional perspective of non-financial management accounting measures: a review of the financial services industry", *Managerial Auditing Journal*, Vol. 17, No. 9, pp. 518-536.

Hussey, J. and Hussey, R. (1997) "*Business Research: A practical guide for undergraduate and postgraduate students*", (Macmillan Press Ltd).

Ittner, C. and Larcker, D. (1995) "Total quality management and the choice of information and reward systems", *Journal of Accounting Research*, Vol. 33, pp. 1-34.

Ittner, C. and Larcker, D. (1998a) "Innovations in performance measurement: trends and research implications", *Journal of Management Accounting Research*, Vol. 10, pp. 205-238.

Ittner, C. and Larcker, D. (1998b) "Are non-financial measures leading indicators of financial performance? An analysis of customer satisfaction", *Journal of Accounting Research*, Vol. 36, No. 3, pp. 1-35.

Ittner, C. and Larcker, D. (2001) "Assessing empirical research in managerial accounting: a value-based management perspective", *Journal of Accounting and Economics*, Vol. 32, No. 1/3, pp. 349-410.

Ittner, C. and Larcker, D. (2003) "Coming up short on nonfinancial performance measurement", *Harvard Business Review*, Vol. 81, No. 11, pp. 88-95.

Ittner, C., Larcker, D. and Meyer, M. (2001) "The anatomy of a balanced scorecard bonus plan", Unpublished Working paper, (University of Pennsylvania).

Ittner, C., Larcker, D. and Meyer, M. (2003) "Subjectivity and the weighting of performance measures: Evidence from a balanced scorecard", *The Accounting Review*, Vol. 78, No. 3, pp. 725-758.

Ittner, C., Larcker, D. and Rajan, M. (1997) "The choice of performance measures in annual bonus contracts", *The Accounting Review*, Vol. 72, No. 2, pp. 231-255.

Ittner, C., Larcker, D. and Randall, T. (2003) "Performance implications of strategic performance measurement in financial services firms", *Accounting, Organizations and Society*, Vol. 28, No. 7/8, pp. 715-741.

- Jensen, M. (1983) "Organization theory and methodology", *The Accounting Review*, Vol. 58, No. 2, pp. 319-339.
- Johnsen, A. (2001) "Balanced scorecard: theoretical perspectives and public management implications", *Managerial Auditing Journal*, Vol. 16, No. 6, pp. 319-330.
- Johnson, H. (1992) "*Relevance Regained: From top-down control to bottom-up empowerment*", (New York: The Free Press).
- Johnson, H. and Kaplan, R. (1987) "*Relevance lost: the rise and fall of management accounting*", (Boston, MA: Harvard Business School Press).
- Joreskog, K. and Sorbom, D. (1982) "Recent developments in structural equation modeling", *Journal of Marketing Research*, Vol. 19, No. 4, pp. 404-416.
- Kald, M. and Nilsson, F. (2000) "Performance measurement at Nordic companies", *European Management Journal*, Vol. 18, No. 1, pp.113-127.
- Kandawalla, P. (1972) "The effects of different types of competition on the use of management controls", *Journal of Accounting Research*, Vol. 10, No. 2, pp. 275-285.
- Kaplan, R. (1983) "Measuring manufacturing performance: A new challenge for managerial accounting research", *The Accounting Review*, Vol. 58, No. 4, pp. 686-705.
- Kaplan, R. (1984) "The evolution of management accounting", *The Accounting Review*, Vol. 59, No. 3, pp. 390-418.
- Kaplan, R. (1994) "Management accounting (1984-1994): development of new practice and theory", *Management Accounting Research*, Vol. 5, No. 3/4, pp. 247-260.
- Kaplan, R. (1998) "Innovation action research: Creating new management theory and practice", *Journal of Management Accounting Research* Vol. 10, pp. 89-118.
- Kaplan, R. and Norton, D. (1992) "The balanced scorecard measures that drive performance", *Harvard Business Review*, Vol. 70, No. 1, pp. 71-79.
- Kaplan, R. and Norton, D. (1993) "Putting the balanced scorecard to work", *Harvard Business Review*, Vol. 71, No. 5, pp. 134-147.
- Kaplan, R. and Norton, D. (1996a) "Using the balanced scorecard as a strategic management system", *Harvard Business Review*, Vol. 74, No. 1, pp. 75-85.
- Kaplan, R. and Norton, D. (1996b) "Linking the balanced scorecard to strategy", *California Management Review*, Vol. 39, No. 1, pp. 53-79.
- Kaplan, R. and Norton, D. (1996c) "*The balanced scorecard*", (Harvard Business School Press).
- Kaplan, R. and Norton, D. (1997) "Why does business need a balanced scorecard?", *Journal of Cost Management*, May/June, pp. 5-10.

Kaplan, R. and Norton, D. (2000) "Having trouble with your strategy? Then map it", *Harvard Business Review*, Vol. 78, No. 5, pp. 167-176.

Kaplan, R. and Norton, D. (2001a) "Transforming the balanced scorecard from performance measurement to strategic management", *Accounting Horizons*, Vol. 15, No. 1, pp. 87-104.

Kaplan, R. and Norton, D. (2001b) "Transforming the balanced scorecard from performance measurement to strategic management", *Accounting Horizons*, Vol. 15, No. 2, pp. 147-160.

Kaplan, R. and Norton, D. (2001c) *The Strategy-Focused Organization: How balanced scorecard companies thrive in the new business environment*, (Boston: Harvard Business School Press).

Kasperskaya, Y. and Oliveras, E. (2003) "The analysis of the balanced scorecard assumptions on empirical evidence from dynamic enterprises", The 26th Annual Congress of the European Accounting Association (Sevilla-Spain).

Keegan, D., Eiler, R. and Jones, C. (1989) "Are your performance measures obsolete", *Management Accounting (USA)*, June, pp. 45-50.

Kennedy, T. and Graves, J. (2001) "The impact of activity-based costing techniques on firm performance", *Journal of Management Accounting Research*, Vol. 13, pp. 19-45.

Kennerley, M. and Neely, A. (2002) "A framework of the factors affecting the evolution of performance measurement systems", *International Journal of Operations & Production Management*, Vol. 22, No.11, pp. 1222-1245.

Kennerley, M. and Neely, A. (2003) "Measuring performance in a changing business environment", *International Journal of Operations & Production Management*, Vol. 23, No. 2, pp. 213-229.

Kim, G., Park, C. and Yoon, P. (1997) "Identifying investment opportunities for advanced manufacturing systems with comparative-integrated performance measurement", *International Journal of Production Economics*, Vol. 50, No. 1, pp. 23-33.

Kloot, L. and Martin, J. (2000) "Strategic performance management: A balanced approach to performance management issues in local government", *Management Accounting Research*, Vol. 11, No. 2, pp. 231-251.

Kreitner, R. (1998) *Management*, 7th edition, (Boston: Houghton Mifflin).

Krumwiede, K. (1998) "The implementation stages of activity-based costing and the impact of contextual and organizational factors", *Journal of Management Accounting Research*, Vol. 10, pp. 239-277.

Laitinen, E. (2002) "A dynamic performance measurement system: evidence from small Finnish technology companies", *Scandinavian Journal of Management*, Vol. 18, No. 1, pp. 65-99.

- Langfield-Smith, K. (1997) "Management control systems and strategy: a critical review", *Accounting, Organizations and Society*, Vol. 22, No. 2, pp. 207-232.
- Larcker, D. (1981) "The perceived importance of selected information characteristics for strategic capital budgeting decisions", *The Accounting Review*, Vol. 56, No. 3, pp. 519-538.
- Lawrence, P. and Lorsch, J. (1967) "*Organization and Environment*" (Boston: Harvard Business School, Division of Research).
- Lawson, R., Stratton, W. and Hatch, T. (2003a) "The benefits of a scorecard system", *CMA Management*, Vol. 77, No. 4, pp. 24-26.
- Lawson, R., Stratton, W. and Hatch, T. (2003b) "The tactical advantage", *CMA Management*, Vol. 77, No. 5, pp. 31-33.
- Leauby, B. and Wentzel, K. (2002) "Know the score: The balanced scorecard approach to strategically assist clients", *Pennsylvania CPA Journal*, Vol. 73, No. 1, pp. 28-32.
- Lebas, M. (1994) "Managerial accounting in France: Overview of past tradition and current practice", *European Accounting Review*, Vol. 3, No. 3, pp. 471-487.
- Lee, J. and Miller, D. (1996) "Strategy, environment and performance in two technological contexts: Contingency theory in Korea", *Organization Studies*, Vol. 17, No. 5, pp. 729-750.
- Letza, S. (1996) "The design and implementation of the balanced business scorecard: An analysis of three companies in practice", *Business Process Re-engineering and Management Journal*, Vol. 2, No. 3, pp. 54-76.
- Libby, T. and Waterhouse, J. (1996) "Predicting change in management accounting systems", *Journal of Management Accounting Research*, Vol. 8, pp. 137-150.
- Lillis, A. (2002) "Managing multiple dimensions of manufacturing performance-an exploratory study", *Accounting, Organizations and Society*, Vol. 27, No. 6, pp. 497-529.
- Lingle, J. and Schiemann, W. (1996) "From balanced scorecard to strategic gauges: Is measurement worth it", *Management Review*, Vol. 85, No. 3, pp.56-61.
- Lipe, M. and Salterio, S. (2000) "The balanced scorecard: Judgmental effects of common and unique performance measures", *The Accounting Review*, Vol. 75, No. 3, pp. 283-298.
- Lipe, M. and Salterio, S. (2002) "A note on the judgemental effects of the Balanced scorecard's information organizations", *Accounting, Organizations and Society*, Vol. 27, No. 6, pp. 531-540.
- Littlewood, F. (1999) "Battle of the scorecard tests", *Times*, 7 December.
- Lohman, C., Fortuin, L. and Wouters, M. (2004) "Designing a performance measurement system: A case study", *European Journal of Operational Research*, Vol. 156, No. 2, pp. 267-286.

Lord, F. (1953) "On the statistical treatment of football numbers", *American Psychologist*, Vol. 8, pp. 750-1.

Lovata, L. and Costigan, M. (2002) "Empirical analysis of adopters of economic value added", *Management Accounting Research*, Vol. 13, No. 2, pp. 215-228.

Lynch, R. and Cross, K. (1995) "*Measure up! How to measure corporate performance*", (USA: Blackwell).

MacCallum, R. (1995) "Model specification: Procedures, strategies, and related issues", pp. 16-36, in R. Hoyle (ed.) *Structural Equation Modeling: Concepts, Issues and Applications* (Thousand Oaks, CA: Sage).

Macintosh, N. and Daft, R. (1987) "Management control systems and departmental interdependence: An empirical study", *Accounting, Organizations and Society*, Vol. 12, No. 1, pp. 49-61.

Maiga, A. and Jacobs, F. (2003) "Balanced scorecard, activity-based costing and company performance: An empirical analysis", *Journal of Managerial Issues*, Vol. 15, No. 3, pp. 283-301.

Maines, L., Bartov, E., Fairfield, P., Hirst, E., Iannaconi, T., Mallett, R., Schrand, C., Skinner, D. and Vincent, L. (2002) "Recommendations on disclosure of nonfinancial performance measures", *Accounting Horizons*, Vol. 16, No. 4, pp. 353-362.

Maisel, L. (1992) "Performance measurement: The balanced scorecard approach", *Journal of Cost Management*, Summer, pp.47-52.

Malina, M. and Selto, F. (2001) "Communicating and controlling strategy: An empirical study of the effectiveness of the balanced scorecard", *Journal of Management Accounting Research*, Vol. 13, pp. 47-89.

Malina, M. and Selto, F. (2004) "Choice and change of measures in performance measurement models", *Management Accounting Research*, Vol. 15, No. 4, pp. 441-469.

Malmi, T. (2001) "Balanced scorecards in Finnish companies: A research note", *Management Accounting Research*, Vol. 12, No. 2, pp. 207-220.

Maltz, A., Shenhar, A. and Reilly, R. (2003) "Beyond the balanced scorecard: Refining the search for organizational success measures", *Long Range Planning*, Vol. 36, No. 2, pp. 187-204.

Marcela, P., Marisol, B. and Javier, A. (2003) "Balanced scorecard: Limitations of its use for performance evaluation purposes", The 26th Annual Congress of the European Accounting Association (Sevilla-Spain).

Marr, B. (2001) "Scored for life", *Financial Management*, April, pp. 30.

Marr, B. and Schiuma, G. (2003) "Business performance measurement-past, present and future", *Management Decision*, Vol. 41, No. 8, pp. 680-687.

Marshall, M., Wray, L., Epstein, P. and Grifel, S. (1999) "21st century community focus: better results by linking citizens, government and performance measurement", *Public Management*, Vol. 81, No.10, pp. 12-19.

Martinsons, M., Davison, R. and Tse, D. (1999) "The balanced scorecard: a foundation for the strategic management of information systems", *Decision Support Systems*, Vol. 25, No. 1, pp. 71-88.

Maruyama, G. (1998) "*Basics of Structural Equation Modeling*", (Thousand Oaks, CA: Sage).

Maskell, B. (1989) "Performance measurement for world class manufacturing", *Manufacturing Horizons*, Part. 3, September, pp. 36-41.

McAdam, R. and Bailie, B. (2002) "Business performance measures and alignment impact on strategy", *International Journal of Operations & Production Management*, Vol. 22, No. 9, pp. 972-996.

McAdam, R. and Bannister, A. (2001) "Business performance measurement and change management within a TQM framework", *International Journal of Operations & Production Management*, Vol. 21, No. 1/2, pp. 88-107.

McCunn, P. (1998) "The balanced scorecard: the eleventh commandment", *Management Accounting (UK)*, Vol. 76, No. 11, pp. 34-36.

McMann, P., Alfred, J. and Nanni, A. (1994) "Is your company really measuring performance", *Management Accounting (USA)*, November, pp. 55-58.

Medori, D. and Steeple, D. (2000) "A framework for auditing and enhancing performance measurement systems", *International Journal of Operations & Production Management*, Vol. 20, No. 5, pp. 520-533.

Medori, G. (1998) "Establishment of non-financial performance measures in medium to large sized organisations", Unpublished PhD Thesis (Coventry University).

Merchant, K. (1981) "The design of the corporate budgeting system: Influences on managerial behaviour and performance", *The Accounting Review*, Vol. 56, No. 4, pp. 813-829.

Merchant, K. (1984) "Influences on departmental budgeting: An empirical examination of a contingency model", *Accounting, Organizations and Society*, Vol. 9, No. 3/4, pp. 291-307.

Merchant, K. (1985) "*Control in Business Organizations*", (Boston: Pitman).

Merchant, K. (1998) "*Modern management control systems: text and cases*", (Upper Saddle River, NJ: Prentice Hall).

Miles, R. and Snow, C. (1978) "*Organizational strategy, structure, and processes*", (New York: McGraw-Hill).

Miller, P. and O'Leary, T. (1993) "Accounting expertise and the politics of the product: economic citizenship and modes of corporate governance", *Accounting, Organizations and Society*, Vol. 18, No. 2/3, pp. 187-206.

Mintzberg, H. (1979) "*The structuring of organizations*", (Upper Saddle River, NJ: Prentice-Hall).

Monden, Y. (1993) "*Toyota Production System*", 2nd edition, (Norcross, GA: Industrial Engineering and Management Press).

Mooraj, S., Oyon, D. and Hostettler, D. (1999) "The balanced scorecard: a necessary good or an unnecessary evil?", *European Management Journal*, Vol. 17, No. 5, pp. 481-491.

Morisette, R. (1998) "Financial and non-financial towards an integrative theory of information choices in organizations", Working Paper (University of Waterloo).

Nagar, V. and Rajan, M. (2001) "The revenue implications of financial and operational measures of product quality", *The Accounting Review*, Vol. 76, No. 4, pp. 495-513.

Nanni, A., Dixon, J. and Vollmann, T. (1992) "Integrated performance measurement: Management accounting to support the new manufacturing realities", *Journal of Management Accounting Research*, Vol. 4, pp. 1-19.

Neely, A. (1999) "The performance measurement revolution: why now and what next", *International Journal of Operations & Production Management*, Vol. 19, No. 2, pp. 205-228.

Neely, A., Adams, C. and Crowe, P. (2001) "The performance prism in practice", *Measuring Business Excellence*, Vol. 5, No. 2, pp. 6-12.

Neely, A., Adams, C. and Kennerley, M. (2002) "*The Performance Prism: The Scorecard for Measuring and Managing Business Success*", (Financial Times-Prentice Hall, London).

Neely, A. and Adams, C. (2001) "The performance prism perspective", *Journal of Cost Management*, Vol. 15, No. 1, pp. 7-15.

Neely, A., Gregory, M. and Platts, K. (1995) "Performance measurement system design: a literature review and research agenda", *International Journal of Operations & Production Management*, Vol. 15, No. 4, pp. 80-116.

Neely, A., Mills, J., Platts, K., Gregory, M. and Richards, H. (1996) "Performance measurement system design: Should process based approaches be adopted?" *International Journal of Production Economics*, Vol. 46/47, No. 3, pp. 423-431.

Neely, A., Mills, J., Platts, K., Richards, H., Gregory, M., Bourne, M. and Kennerley, M. (2000) "Performance measurement system design: developing and testing a process-based approach", *International Journal of Operations & Production Management*, Vol. 20, No.10, pp. 1119-1145.

Nielsen, S. and Sorensen, R. (2003) "Motives, diffusion and utilization of the balanced scorecard in Denmark", The 26th Annual Congress of the European Accounting Association (Sevilla-Spain).

Nilson, F. and Kald, M. (2002) "Recent advances in performance management: The Nordic case", *European Management Journal*, Vol. 20, No. 3, pp. 235-245.

Norreklit, H. (2000) "The balance on the balanced scorecard-a critical analysis of some of its assumptions", *Management Accounting Research*, Vol. 11, No. 1, pp. 65-88.

Norreklit, H. (2003) "The balanced scorecard: what is the score? A rhetorical analysis of the balanced scorecard", *Accounting, Organizations and Society*, Vol. 28, No. 6, pp. 591-619.

Nunnally, J. (1978) "*Psychometric Theory*", (New York: McGraw-Hill).

Oakland, J. (1999) "Boardroom briefing, wining performance through business excellence", *Credit Control*, Vol. 43, No. 7, pp. 23-31.

Oliveras, E. and Amat, O. (2002) "The balanced scorecard assumptions and the drivers of business growth", The 25th Annual Congress of the European Accounting Association (Copenhagen-Denmark).

Olson, E. and Slater, S. (2002) "The balanced scorecard, competitive strategy, and performance", *Business Horizons*, Vol. 45, No. 3, pp. 11-16.

Olve, N., Roy, J. and Wetter, M. (1999) "*Performance Drivers: A Practical Guide to Using the Balanced Scorecard*", (John Wiley & Sons, Chichester, England).

Oppenheim, A. (1992) "*Questionnaire Design, Interviewing and Attitude Measurement*", new edition, (New York: Printer Publishers).

Otley, D. (1978) "Budget use and managerial performance", *Journal of Accounting Research*, Vol. 16, No. 1, pp. 122-149.

Otley, D. (1980) "The contingency theory of management accounting: achievement and prognosis", *Accounting, Organizations and Society*, Vol. 5, No. 4, pp. 413-428.

Otley, D. (1987) "Accounting for divisional planning and control", in *Management Planning and Control*, revised edition, edited by K. Ferris, and J. Livingstone, pp. 83-119. Beaver Creek, OH: Century VIII.

Otley, D. (1994) "Management control in contemporary organisations: towards a wider framework", *Management Accounting Research*, Vol. 5, No. 3/4, pp. 289-299.

Otley, D. (1997) "Better performance management", *Management Accounting (UK)*, Vol. 75, No. 1, pp. 44-45.

Otley, D. (1999) "Performance management: a framework for management control systems research", *Management Accounting Research*, Vol. 10, No. 4, pp. 363-382.

Otley, D. (2001) "Extending the boundaries of management accounting research: Developing systems for performance management", *British Accounting Review*, Vol. 33, No. 3, pp. 243-261.

Otley, D. and Wilkinson, C. (1988) "Organizational behaviour: strategy, structure, environment and technology", in K. Ferris (ED.), *Behavioural accounting research: a critical analysis* (pp. 147-170), (New York: Century Publications Co.).

Otley, D., Broadbent, J. and Berry, A. (1995) "Research in management control: An overview of its development", *British Journal of Management*, Vol. 6, No. 6, pp. 31-44.

Ouchi, W. (1977) "The relationship between organizational structures and organizational control", *Administrative Science Quarterly*, Vol. 22, No. 1, pp. 95-112.

Ouchi, W. (1979) "A conceptual framework for the design of organizational control mechanisms", *Management Science*, Vol. 25, No. 9, pp. 833-849.

Pallant, J. (2001) "*SPSS Survival manual: A step by step guide to data analysis using SPSS for windows*", *Versions 10 and 11*, (Open University Press).

Paulsen, K. (2001) "Bringing the score up-by taking it down", *Agency Sales*, Vol. 31, No. 9, pp. 15-17.

Pere, T. (1999) "How the execution of strategy is followed in large organisations located in Finland", Masters Thesis (Helsinki School of Economics and Business Administration).

Perera, S., Harrison, G. and Poole, M. (1997) "Customer-focused manufacturing strategy and the use of operation-based non-financial performance measures: A research note", *Accounting, Organizations and Society*, Vol. 22, No. 6, pp. 557-572.

Perrow, C. (1967) "A framework for the comparative analysis of organizations", *American Sociological Review*, Vol. 32, No. 2, pp. 194-208.

Phillips, P. (1999) "Hotel performance and competitive advantage: a contingency approach", *International Journal of Contemporary Hospitality Management*, Vol. 11, No. 7, pp. 359-365.

Porter, M. (1980) "*Competitive Strategy Techniques for Analyzing Industries and Competitors*", (New York: Free Press).

Porter, M. (1985) "*Competitive Advantage: Creating and Sustaining Superior Performance*", (New York: Free Press).

Protti, D. (2002) "A proposal to use a balanced scorecard to evaluate information for Health: an information strategy for the modern NHS (1998-2005)", *Computers in Biology and Medicine*, Vol. 32, No. 3, pp. 221-236.

Pugh, D. (1973) "The measurement of organization structures: does context determine form?", *Organizational Dynamics*, Vol. 1, No. 4, pp. 19-34.

- Radnor, Z. and Lovell, B. (2003) "Success factors for implementation of the balanced scorecard in a NHS multi-agency setting", *International Journal of Health Care Quality Assurance*, Vol. 16, No. 2, pp. 99-108.
- Ramamurthy, K. (1990) "Role of environmental, organizational and technological factors in information technology implementation in advanced manufacturing: An innovation adoption-diffusion perspective", Unpublished PhD Thesis (University of Pittsburgh).
- Rangone, A. (1997) "Linking organisational effectiveness, key success factors and performance measures: an analytical framework", *Management Accounting Research*, Vol. 8, No. 2, pp. 207-219.
- Rappaport, A. (1999) "New thinking on how to link executive pay with performance", *Harvard Business Review*, Vol. 77, No. 2, pp. 91-101.
- Rigby, D. (2001) "Management tools and techniques: A survey", *California Management Review*, Vol. 43, No. 2, pp. 139-160.
- Ritter, M. (2003) "The use of balanced scorecards in the strategic management of corporate communication", *Corporate Communications*, Vol. 8, No. 1, pp. 44-59.
- Roest, P. (1997) "The golden rules for implementing the balanced business scorecard", *Information Management & Computer Security*, Vol. 5, No. 5, pp. 163-165.
- Rouse, P., Putterill, M. and Ryan, D. (2002) "Integrated performance measurement design: insights from an application in aircraft maintenance", *Management Accounting Research*, Vol. 13, No. 2, pp. 229-248.
- Rucci, A., Kirn, S. and Quinn, R. (1998) "The employee-customer profit chain at Sears", *Harvard Business Review*, Vol. 76, No. 1, pp. 82-97.
- Ruyter, K. and Wetzels, M. (1999) "Commitment in auditor-client relationships: antecedents and consequences", *Accounting, Organizations and Society*, Vol. 24, No. 1 pp. 57-75.
- Ryan, B., Scapens, R. and Theobald, M. (2002) "*Research method and methodology in finance and accounting*", 2nd edition, (Thompson).
- Said, A., HassabElnaby, H. and Wier, B. (2003) "An empirical investigation of the performance consequences of nonfinancial measures", *Journal of Management Accounting Research*, Vol. 15, pp. 193-223.
- Salterio, S. and Webb, A. (2003) "The balanced scorecard", *CA magazine*, Vol. 136, No. 6, pp. 39-41.
- Sandstorm, J. and Toivanen, J. (2002) "The problem of managing product development engineers: Can the balanced scorecard be an answer?", *International Journal of Production Economics*, Vol. 78, No. 1, pp. 79-90.

Sandt, J., Schaffer, U. and Weber, J. (2001) "Balanced performance measurement systems and manager satisfaction-empirical evidence from a German study", Working paper (WHU-Otto Beisheim Graduate School of Management).

Sanger, M. (1998) "Supporting the balanced scorecard", *Work Study*, Vol. 47, No. 6, pp.197-200.

Saunders, M., Lewis, P. and Thornhill, A. (2000) "*Research Methods for Business Students*", 2nd edition, (London: Prentice Hall).

Scapens, R. (1991) "*Management accounting: a review of contemporary developments*", (Macmillan).

Scapens, R. and Arnold, J. (1986) "Economics and management accounting research", pp. 78-102 in Bromwich, M. and Hopwood, A. (eds) *Research and current issues in management accounting*, (Pitman: London).

Schiemann, W. and Lingle, J. (1999) "*Bullseye!: hitting your strategic targets through high-impact measurement*", (New York: The Free Press).

Schoute, M. (2002) "Evaluating the performance consequences of management accounting innovations: Theoretical and methodological issues", The 25th Annual Congress of the European Accounting Association (Copenhagen-Denmark).

Schumacker, R. and Lomax, R. (1996) "*A Beginner's Guide to Structural Equation Modeling*", (New Jersey: Lawrence Erlbaum Associates).

Scott, T. and Tiessen, P. (1999) "Performance measurement and managerial teams", *Accounting, Organizations and Society*, Vol. 24, No. 3, pp. 263-285.

Sekaran, U. (1992) "*Research methods for business: a skill-building approach*", 2nd edition, (John Wiley & Sons, Inc, Singapore).

Sekaran, U. (2003) "*Research methods for business: a skill-building approach*", 4th edition, (John Wiley & Sons, Inc).

Shank, J. (1989) "Strategic cost management: New wine or just new bottles?", *Journal of Management Accounting Research*, Vol. 1, pp. 47-65.

Sharma, D. (2002) "The differential effect of environmental dimensionality, size and structure on budget system characteristics in hotels", *Management Accounting Research*, Vol. 13, No. 1, pp. 101-130.

Shields, M. (1998) "Management accounting practices in Europe: A perspective from the states", *Management Accounting Research*, Vol. 9, No. 4, pp. 501-513.

Silk, S. (1998) "Automating the balanced scorecard", *Management Accounting (USA)*, Vol. 79, No. 11, pp. 38-44.

Sim, K. and Killough, L. (1998) "The performance effects of complementarities between manufacturing practices and management accounting systems", *Journal of Management Accounting Research*, Vol. 10, pp. 325-346.

Simons, R. (1987) "Accounting control systems and business strategy: An empirical analysis", *Accounting, Organizations and Society*, Vol. 12, No. 4, pp. 357-374.

Simons, R. (1990) "The role of management control systems in creating competitive advantage: new perspectives", *Accounting, Organizations and Society*, Vol. 15, No. 1/2, pp. 127-143.

Simons, R. (2000) "*Performance Measurement & Control Systems for Implementing Strategy*", (Prentice Hall, Upper Saddle River, NJ).

Singhapakdi, A., Vitell, S. and Franke, G. (1999) "Antecedents, consequences, and mediating effects of perceived moral intensity and personal moral philosophies", *Journal of the Academy of Marketing Science*, Vol. 27, No. 1, pp. 19-36.

Sisaye, S. (1998) "An overview of the social and behavioral sciences approaches in management control research", *Behavioral Research in Accounting*, Vol. 10, Supplement, pp. 11-26.

Smith, D. and Langfield-Smith, K. (2002) "Structural equation modeling in management accounting: Critical analysis and opportunities", Unpublished paper (Monash University, Australia).

Smith, M. (1997) "Putting NFIs to work in a balanced scorecard environment", *Management Accounting (UK)*, Vol. 75, No. 3, pp. 32-35.

Smith, M. (2002) "Gaming non-financial performance measures", *Journal of Management Accounting Research*, Vol. 14, pp. 119-133.

Sohn, M., You, T., Lee, S. and Lee, H. (2003) "Corporate strategies, environmental forces, and performance measures: a weighting decision support system using the k-nearest neighbour technique", *Expert Systems with Applications*, Vol. 25, No. 3, pp. 279-292.

Southern, G. (2002) "From teaching to practice, via consultancy, and then to research", *European Management Journal*, Vol. 20, No. 4, pp. 401-408.

Speckbacher, G., Bischof, J. and Pfeiffer, T. (2003) "A descriptive analysis on the implementation of balanced scorecards in German-speaking countries", *Management Accounting Research*, Vol. 14, No. 4, pp. 361-387.

Srinivasan, D. (1997) "Relation between financial and non-financial measures of performance", Unpublished Doctoral Thesis (University of Minnesota, Minneapolis, MN).

Steenkamp, J. and Baumgartner, H. (2000) "On the use of structural equation models for marketing modeling", *International Journal of Research in Marketing*, Vol. 17, No. 2/3, pp. 195-202.

- Stivers, B., Covin, T., Hall, N. and Smalt, S. (1998) "How non-financial performance measures are used", *Management Accounting (USA)*, Vol. 79, No. 8, pp. 44-49.
- Thompson, J. (1967) "*Organizations in Action*", (New York: McGraw-Hill).
- Tiessen, P. and Waterhouse, J. (1983) "Towards a descriptive theory of management accounting", *Accounting, Organizations and Society*, Vol. 8, No. 2/3, pp. 251-267.
- Tillema, S. (2005) "Towards an integrated contingency framework for MAS sophistication: Case studies on the scope of accounting instruments in Dutch power and gas companies", *Management Accounting Research*, Vol. 16, No. 1, pp. 101-129.
- Tosi, H., Aldag, R. and Storey, R. (1973) "On the measurement of the environment: An assessment of the Lawrence and Lorsch environmental uncertainty questionnaire", *Administrative Science Quarterly*, Vol. 18, No. 1, pp. 27-37.
- Tosi, H. and Slocum, J. (1984) "Contingency theory: Some suggested directions", *Journal of Management*, Vol. 10, No. 1, pp. 9-26.
- Tymon, W., Stout, D. and Shaw, K. (1998) "Critical analysis and recommendation regarding the role of perceived environmental uncertainty in behavioural accounting research", *Behavioral Research in Accounting*, Vol. 10, pp. 23-46.
- Upton, D. (1998) "Just-in-time and performance measurement systems", *International Journal of Operations & Production Management*, Vol. 18, No. 11, pp. 1101-1110.
- Vaivio, J. (1999) "Exploring a non-financial management accounting change", *Management Accounting Research*, Vol. 10, No. 4, pp. 409-437.
- Van de Ven, A. and Drazin, R. (1985) "The concept of fit in contingency theory", *Research in Organizational Behavior*, Vol. 7, pp. 333-365.
- Van der Stede, W., Chow, C. and Lin, T. (2001) "Strategy, choice of performance measures, and performance", Working Paper (University of Southern California and San Diego State University).
- Veen-Dirks, P. and Wijn, M. (2002) "Strategic control: Meshing critical success factors with the balanced scorecard", *Long Range Planning*, Vol. 35, No. 4, pp. 407-427.
- Venkatraman, N. (1989) "The concept of fit in strategy research: Toward verbal and statistical correspondence", *Academy of Management Review*, Vol. 14, No. 3, pp. 423-444.
- Verbeeten, F. (2004) "Performance measurement and long-term managerial contracts: An empirical investigation", The 27th Annual Congress of the European Accounting Association (Prague-Czech Republic).
- Wachtel, T., Hartford, C. and Hughes, J. (1999) "Building a balanced scorecard for a burn centre", *Burns*, Vol. 25, No. 5, pp. 431-437.

Wallace, R. and Mellor, C. (1988) "Nonresponse bias in mail accounting surveys: A pedagogical note", *British Accounting Review*, Vol. 20, No. 2, pp. 131-139.

Waterhouse, J. and Tiessen, P. (1978) "A contingency framework for management accounting systems research", *Accounting, Organizations and Society*, Vol. 3, No. 1, pp. 65-76.

Watts, R. and Zimmerman, J. (1986) *Positive accounting theory*, (Englewood Cliffs: Prentice Hall).

Wenisch, S. (2003) "Introducing the balanced scorecard in a divisionalized company: A study of organizational change from a diffusion perspective", The 26th Annual Congress of the European Accounting Association (Seville-Spain).

West, S., Finch, J. and Curran, P. (1995) "Structural equation models with nonnormal variables: Problems and remedies", pp. 56-75, in R. Hoyle (ed.) *Structural Equation Modeling: Concepts, Issues and Applications*, (Thousand Oaks, CA: Sage).

Westlund, A. (2001) "Measuring environmental impact on society in the EFQM system", *Total Quality Management*, Vol.12, No.1, pp. 125-135.

Widener, S. (2004) "An empirical investigation of the relation between the use of strategic human capital and the design of the management control system", *Accounting, Organizations and Society*, Vol. 29, No. 3/4, pp. 377-399.

Williams, S. (2001) "Drive your business forward with the balanced scorecard", *Management Services*, Vol. 45, No. 6, pp. 28-30.

Wonggrassamee, S., Gardiner, P. and Simmions, J. (2003) "Performance measurement tools: the Balanced Scorecard and the EFQM Excellence Model", *Measuring Business Excellence*, Vol. 7, No.1, pp.14-29.

Woodward, J. (1965) *Industrial Organization: Theory and Practice*, (London: Oxford University Press).

Wouters, M., Kokke, K., Theeuwes, J. and Donselaar, K. (1999) "Identification of critical operational performance measures-a research note on a benchmarking study in the transportation and distribution sector", *Management Accounting Research*, Vol. 10, No. 4, pp. 439-452.

Yeniyurt, S. (2003) "A literature review and integrative performance measurement framework for multinational companies", *Marketing Intelligence & Planning*, Vol. 21, No. 3, pp. 134-142.

Young, S. and Selto, F. (1991) "New manufacturing practices and cost management: A review of the literature and directions for research", *Journal of Accounting Literature*, Vol. 29, No. 3, pp. 265-298.

Zmud, R. (1982) "Diffusion of modern software practices: Influence of centralization and formalization", *Management Science*, Vol. 28, No. 12, pp.1421-1431.

Appendices

Appendix A: Research questionnaire.....	A1
Appendix B: Questionnaire covering letter.....	B1
Appendix C: Questionnaire first reminder letter.....	C1
Appendix D: Questionnaire second reminder letter.....	D1



University of
HUDDERSFIELD

Appendix A: Research questionnaire

**Performance measurement systems in UK manufacturing companies
(With specific emphasis on factors influencing their effective usage)**

Questionnaire Survey

Dear participant:

We are currently undertaking a research project relating to performance measurement systems in UK manufacturing companies. The research aims to describe the nature, content and use of performance measures. A major objective of the research is to examine the factors influencing the effective use of performance measurement systems.

Your response is extremely important to the success of this study and will be treated as **strictly confidential**. The information shown in the top right hand corner will be used only to identify who has returned the questionnaire. It will not be disclosed to third parties under any circumstances. Please answer the questionnaire from the perspective of the business unit that most clearly defines where you work (e.g. a head office of a divisionalised company, a division of a divisionalised company, a non-divisionalised company, etc). Also please note that the questions have been written to ensure that they are applicable to many types of businesses. Therefore, it is possible that they may not all exactly apply to your situation. Nevertheless, please attempt to answer all questions. However, if you are unsure about a response, or think it would be misleading, please leave the specific question unanswered. When you have completed the questionnaire, please return it in the enclosed postage-paid envelope.

Thank you very much for your help and co-operation

Professor Colin Drury
Huddersfield University Business School
Department of Accountancy and Finance
Queensgate
Huddersfield
HD1 3DH
E-mail: j.c.drury@hud.ac.uk
Tel. 01484 472299

Mr. Majdy Zuriekat
Huddersfield University Business School
Department of Accountancy and Finance
Queensgate
Huddersfield
HD1 3DH
E-mail: m.zuriekat@hud.ac.uk
Tel. 01484 473804

SECTION A: THE PERFORMANCE MEASUREMENT SYSTEM WITHIN YOUR BUSINESS UNIT

Part 1. For each of the categories listed below, please indicate (i) the importance of performance indicators falling within each category as drivers of the long-term success of your business unit and (ii) the extent to which strategic goals are set for each performance category. Using the scales below, please circle the most appropriate responses respectively for (i) importance as drivers of long-term success and (ii) extent strategic goals set.

<u>Performance categories</u>	<u>(i) Importance to long-term success</u>							<u>(ii) Extent strategic goals set</u>						
	Not at all important		Moderate importance			Extremely important		No goals established		Moderately established			Explicit goals established	
A1. Financial (e.g. annual earnings, return on assets, cost reduction, etc)	1	2	3	4	5	6	7	1	2	3	4	5	6	7
A2. Customer (e.g. market share, customer satisfaction, customer retention, etc)	1	2	3	4	5	6	7	1	2	3	4	5	6	7
A3. Operational performance (e.g. cycle time, productivity, safety, etc)	1	2	3	4	5	6	7	1	2	3	4	5	6	7
A4. Innovation (e.g. new product development success, development cycle time, etc)	1	2	3	4	5	6	7	1	2	3	4	5	6	7
A5. Employee (e.g. turnover, employee satisfaction, workforce capabilities, etc)	1	2	3	4	5	6	7	1	2	3	4	5	6	7
A6. Supplier (e.g. on-time delivery, input into product design, etc)	1	2	3	4	5	6	7	1	2	3	4	5	6	7
A7. Environment (e.g. government citations, certification, etc)	1	2	3	4	5	6	7	1	2	3	4	5	6	7
A8. Quality (e.g. defect rates, quality awards, etc)	1	2	3	4	5	6	7	1	2	3	4	5	6	7
A9. Community (e.g. public image, community involvement, etc)	1	2	3	4	5	6	7	1	2	3	4	5	6	7

Part 2. For each of the categories listed below, please indicate (i) the extent to which relevant indicators within each category are used to evaluate managerial performance and (ii) the extent to which performance indicators falling within each category are linked to the managerial financial reward system. Using the scales below, please circle the most appropriate responses respectively for (i) extent used for managerial performance evaluation and (ii) financial reward system.

<u>Performance categories</u>	<u>(i) Managerial performance evaluation</u>							<u>(ii) Financial reward system</u>						
	Not used at all		Moderately used			Used extensively		Not at all linked		Moderately linked			Extensively linked	
A10. Financial (e.g. annual earnings, return on assets, cost reduction, etc)	1	2	3	4	5	6	7	1	2	3	4	5	6	7
A11. Customer (e.g. market share, customer satisfaction, customer retention, etc)	1	2	3	4	5	6	7	1	2	3	4	5	6	7
A12. Operational performance (e.g. cycle time, productivity, safety, etc)	1	2	3	4	5	6	7	1	2	3	4	5	6	7
A13. Innovation (e.g. new product development success, development cycle time, etc)	1	2	3	4	5	6	7	1	2	3	4	5	6	7
A14. Employee (e.g. turnover, employee satisfaction, workforce capabilities, etc)	1	2	3	4	5	6	7	1	2	3	4	5	6	7
A15. Supplier (e.g. on-time delivery, input into product design, etc)	1	2	3	4	5	6	7	1	2	3	4	5	6	7
A16. Environment (e.g. government citations, certification, etc)	1	2	3	4	5	6	7	1	2	3	4	5	6	7
A17. Quality (e.g. defect rates, quality awards, etc)	1	2	3	4	5	6	7	1	2	3	4	5	6	7
A18. Community (e.g. public image, community involvement, etc)	1	2	3	4	5	6	7	1	2	3	4	5	6	7

Part 3. For each of the categories listed below, please (i) rate how well your business unit measures performance within each category and (ii) the extent to which performance indicators within each category are used to identify problems and improvement opportunities and developing action plans. Using the scales below, please circle the most appropriate responses respectively for (i) measurement quality and (ii) problem identification.

Performance categories	(i) Measurement quality							(ii) Problem identification						
	Extremely poor quality		Neutral			Extremely high quality		Not used at all		Moderately used			Used extensively	
	1	2	3	4	5	6	7	1	2	3	4	5	6	7
A19. Financial (e.g. annual earnings, return on assets, cost reduction, etc)	1	2	3	4	5	6	7	1	2	3	4	5	6	7
A20. Customer (e.g. market share, customer satisfaction, customer retention, etc)	1	2	3	4	5	6	7	1	2	3	4	5	6	7
A21. Operational performance (e.g. cycle time, productivity, safety, etc)	1	2	3	4	5	6	7	1	2	3	4	5	6	7
A22. Innovation (e.g. new product development success, development cycle time, etc)	1	2	3	4	5	6	7	1	2	3	4	5	6	7
A23. Employee (e.g. turnover, employee satisfaction, workforce capabilities, etc)	1	2	3	4	5	6	7	1	2	3	4	5	6	7
A24. Supplier (e.g. on-time delivery, input into product design, etc)	1	2	3	4	5	6	7	1	2	3	4	5	6	7
A25. Environment (e.g. government citations, certification, etc)	1	2	3	4	5	6	7	1	2	3	4	5	6	7
A26. Quality (e.g. defect rates, quality awards, etc)	1	2	3	4	5	6	7	1	2	3	4	5	6	7
A27. Community (e.g. public image, community involvement, etc)	1	2	3	4	5	6	7	1	2	3	4	5	6	7

A28. Using the scale below, please indicate the extent to which the performance measurement system incorporates performance measures that can be directly linked to the strategies of your business unit.

Not at all	To a moderate extent			To a considerable extent		
1	2	3	4	5	6	7

A29. For the purpose of this study a cause-and-effect relationship is defined as a method that links the non-financial performance measures and also links these measures to financial performance outcomes. Using the scale below, please indicate the extent to which the eight non-financial performance categories listed in parts 1-3 above are causally linked to each other and also to future financial performance outcomes of your business unit.

(e.g. *innovation* → *operational* → *customer* → *financial categories*)

Not at all	To a moderate extent			To a considerable extent		
1	2	3	4	5	6	7

SECTION B: QUESTIONS RELATED TO BALANCED SCORECARD (BSC)

In this section, we would like to obtain a general understanding of how companies are dealing with the concept of Balanced Scorecard (BSC).

B1. Regarding Balanced Scorecard (BSC), please circle one of the following stages that best describes your business unit's current situation.

Not considered	Implemented & abandoned	Considering	Approved for implementation	Implementing now	Used	Used extensively
1	2	3	4	5	6	7

Note: If you have answered (1 or 2 or 3), please omit questions B2-B5, and complete sections (C, D, E, F, G, H, and I).

B2. Please tick which of the following are included as separate perspectives within your Balanced Scorecard (BSC).

- Financial
- Customer
- Internal business process (i.e. operational)
- Learning and growth (i.e. innovation)
- Supplier
- Employee
- Environment
- Other (please specify)-----

B3. For the perspectives that you have ticked in your response to question B2, please enter (i) the number of strategic objectives and (ii) the number of performance measures that are incorporated in the scorecard for each perspective.

Perspective	(i) Number of strategic objectives	(ii) Number of performance measures
Financial		
Customer		
Internal business process		
Learning and growth		
Supplier		
Employee		
Environment		
Other (please specify)		
.....		

B4. Please tick which of the following best describes the results your business unit has achieved through the use of the Balanced Scorecard (BSC).

- We have achieved quantifiable breakthrough financial results
- We have achieved operational results (e.g. process improvements, increased efficiency)
- We have achieved other organisational benefits (e.g. communication, organisational alignment)
- Too early to tell about the results
- No results
- The program failed
- Other (please specify)-----

B5. Please tick the appropriate levels within your company where the Balanced Scorecard has/will be applied.

- At the corporate level
- At the business unit level
- At the plant level
- At the department level
- At the team level
- At the employee level

SECTION C: ABOUT YOUR BUSINESS UNIT

Part 1. The following questions help us to categorise your business unit by type and activities. For each question, please write your answer in the space provided.

- C1. Please specify the approximate number of employees (full-time equivalents) currently employed in your business unit -----employees
- C2. Please specify the approximate annual sales turnover for your business unit for the last financial year £-----million
- C3. In what type of business/industry is your business unit engaged? (please be specific: e.g. steel manufacturing, textiles, food processing) -----

Part 2. The following statements help us to develop a greater understanding of your business unit type. Using the scale below, please indicate for each item your estimate of the position of your business unit relative to its leading competitors in the following areas (please circle one number for each statement).

	Significantly lower 1	Lower 2	Slightly lower 3	About the same 4	Slightly higher 5	Higher 6	Significantly higher 7				
C4. Product selling prices					1	2	3	4	5	6	7
C5. Manufacturing costs					1	2	3	4	5	6	7
C6. Percent of sales spent on research and development					1	2	3	4	5	6	7
C7. Percent of sales spent on marketing expenses					1	2	3	4	5	6	7
C8. Product quality					1	2	3	4	5	6	7
C9. Brand image					1	2	3	4	5	6	7
C10. Product features					1	2	3	4	5	6	7

SECTION D: ABOUT YOUR INTERNAL OPERATING ENVIRONMENT

The following statements relate to the internal operating environment of your business unit. Using the scale below, please circle for each statement the appropriate response relating to the extent to which you agree or disagree with each of the following. Please note if any of the decisions specified in questions D1 - D6 are not applicable to your business unit enter the term 'N/A' next to the question number.

	Strongly disagree 1	Disagree 2	Slightly disagree 3	Neutral 4	Slightly agree 5	Agree 6	Strongly agree 7				
D1. New product introduction decisions are made only at the highest management level					1	2	3	4	5	6	7
D2. Apart from minor investments, capital budgeting decisions are usually made only at the top management level					1	2	3	4	5	6	7
D3. Decisions to attempt penetration into new markets generally are made only by top management					1	2	3	4	5	6	7
D4. Decisions on major changes to (including new introduction of) manufacturing processes are made only at the top management level					1	2	3	4	5	6	7
D5. Personnel policy decisions are usually made by top management					1	2	3	4	5	6	7
D6. Pricing policies are set only by top management					1	2	3	4	5	6	7
D7. Rules and procedures in your business unit are very clearly documented					1	2	3	4	5	6	7
D8. There is always an extensive reliance on rules and procedures to meet operating emergencies					1	2	3	4	5	6	7
D9. Violation of the documented procedures is not tolerated					1	2	3	4	5	6	7

SECTION E: ABOUT YOUR INDUSTRY ENVIRONMENT

The following statements describe some of the factors that are constantly in the process of changing in the external environment. Using the scale below, please circle for each statement the number that corresponds to the predictability or unpredictability of the rate of change within your business unit.

Highly predictable rate of change	Fairly predictable	Slightly predictable	Neutral	Slightly unpredictable	Fairly unpredictable	Highly unpredictable rate of change
1	2	3	4	5	6	7

- E1. Manufacturing technology 1 2 3 4 5 6 7
- E2. Competitors' actions 1 2 3 4 5 6 7
- E3. Customers' demand 1 2 3 4 5 6 7
- E4. Product attributes/design 1 2 3 4 5 6 7
- E5. Raw material availability 1 2 3 4 5 6 7
- E6. Raw materials price 1 2 3 4 5 6 7
- E7. Government regulation 1 2 3 4 5 6 7
- E8. Labour unions actions 1 2 3 4 5 6 7

SECTION F: ABOUT YOUR MANUFACTURING PRACTICES

Part 1. On the scale below, please circle for each statement one of the numbers to indicate the extent to which you agree or disagree with the following statements relating to the quality initiatives that have taken place within your business unit.

Strongly disagree	Disagree	Slightly disagree	Neutral	Slightly agree	Agree	Strongly agree
1	2	3	4	5	6	7

- F1. Workers are rewarded for quality improvement 1 2 3 4 5 6 7
- F2. Experiments to improve the quality of processes are frequently conducted 1 2 3 4 5 6 7
- F3. Quality benchmarking with other companies or business units is tracked 1 2 3 4 5 6 7
- F4. Employee teams are functioning and have been effective 1 2 3 4 5 6 7
- F5. Total quality management, whereby most business functions are involved in a process of continuous quality improvement, is an extremely high priority 1 2 3 4 5 6 7

Part 2. On the scale below, please circle for each statement one of the numbers to indicate the extent to which you agree or disagree with the following statements which relate to just in time initiatives within your business unit.

Strongly disagree	Disagree	Slightly disagree	Neutral	Slightly agree	Agree	Strongly agree
1	2	3	4	5	6	7

- F6. Materials or component parts are delivered as needed rather than in large batches 1 2 3 4 5 6 7
- F7. Set-up times are frequently reduced 1 2 3 4 5 6 7
- F8. Production is automatically halted if defective work is produced 1 2 3 4 5 6 7
- F9. The plant layout is organised in flexible manufacturing cells 1 2 3 4 5 6 7
- F10. Cross-training and job rotation are required 1 2 3 4 5 6 7

SECTION G: ABOUT YOUR MARKET COMPETITION

The following statements relate to the level of competition in the market place. Using the scale below, please circle for each statement the appropriate response to the intensity of your business unit's market competition.

Of negligible intensity	Moderately intense					Extremely intense
1	2	3	4	5	6	7
G1. Price competition						
G2. Competition for selling and distribution						
G3. Competition for quality and variety of products						
G4. Competition for market share						
G5. Competition relating to customer service						
G6. Number of competitors in your market segment						
G7. Competitors' actions						

SECTION H: ABOUT THE EFFECTIVENESS OF YOUR PERFORMANCE MEASUREMENT SYSTEM

Part 1. The following statements help us to develop a greater understanding of the satisfaction of the current performance measurement system.

H1. On the scale below, please circle the appropriate number to indicate how well the performance measurement system of your business unit currently meets expectations.

Does not meet expectations	Moderately meets expectations				Exceeds expectations	
1	2	3	4	5	6	7

H2. On the scale below, please circle the appropriate number to indicate how well the performance measurement system of your business unit compares to your understanding of the concept of an "ideal" system.

Not at all ideal	Moderately ideal			Very close to ideal		
1	2	3	4	5	6	7

H3. On the scale below, please circle the appropriate number to indicate your overall satisfaction with the performance measurement system of your business unit.

Not at all satisfied	Moderately satisfied			Completely satisfied		
1	2	3	4	5	6	7

Part 2. The following statements help us to develop a greater understanding of your business unit performance. For each of the dimensions listed below, please indicate (i) how important you perceive each is in determining the success of your business unit as a whole and (ii) how well you perceive your business unit actually performed over the last three years relative to your competitors. Using the scales below, please circle the most appropriate responses respectively for (i) importance and (ii) performance for each of items H4 to H11.

	i) <u>Importance</u>							ii) <u>Performance</u>						
	Not Important		Uncertain			Vitaly important		Poor		Average			Outstanding	
H4. Cash flow	1	2	3	4	5	6	7	1	2	3	4	5	6	7
H5. Market share	1	2	3	4	5	6	7	1	2	3	4	5	6	7
H6. Return on investment	1	2	3	4	5	6	7	1	2	3	4	5	6	7
H7. New product development	1	2	3	4	5	6	7	1	2	3	4	5	6	7
H8. Market development	1	2	3	4	5	6	7	1	2	3	4	5	6	7
H9. Cost reduction	1	2	3	4	5	6	7	1	2	3	4	5	6	7
H10. Research and development	1	2	3	4	5	6	7	1	2	3	4	5	6	7
H11. Personnel development	1	2	3	4	5	6	7	1	2	3	4	5	6	7

H12. Using the right hand scale above, please indicate the overall performance of your business unit compared to your competitors over the last three years. 1 2 3 4 5 6 7

SECTION I: GENERAL QUESTIONS

The following questions are designed to enable us to classify your answers. We reiterate that all information you provide is strictly **CONFIDENTIAL** and any information identifying the respondent will not be disclosed under any circumstances.

I1. Please insert your job title/position in the organisational structure -----

I2. How many years have you been in this current position? ----- years

I3. How many years of working experience do you have? ----- years
(including experience prior to joining this business unit)

I4. Please alter the label on the front of the questionnaire if your name, job title and company name and address are not correct. Also please provide us with the following information which will only be used to contact you in exceptional circumstances to clarify any responses.

E-mail ----- Telephone number -----

I5. Would it possible for a short meeting to be arranged to discuss some of the issues in questionnaire
Meeting possible () Meeting not possible ()

I6. Please tick the box if you wish to receive a copy of the aggregated results of this study ()

No More Questions. Thank you very much for your assistance in completing this questionnaire. We would appreciate any comments or suggestions you may care to make about any subject mentioned in the questionnaire. You may use the space below, or use a separate sheet and return it with the completed questionnaire or separately -----

Please use the enclosed prepaid envelope to return the questionnaire. In the event of having misplaced the prepaid envelope, please return the questionnaire to: Professor Colin Drury, Huddersfield University Business School, Department of Accountancy and Finance, Queensgate, Huddersfield, HD1 3DH.



University of
HUDDERSFIELD

Appendix B: Questionnaire covering letter

Date:

Dear

We are currently undertaking research relating to performance measurement systems. The research aims to describe the nature, content and use of performance measures within today's changing environment. A major objective of the research is to examine the factors influencing the effective use of performance measurement systems in UK manufacturing companies.

The research objectives can only be achieved and the role of management accounting enhanced with your co-operation. Therefore we are writing to ask you if you would be prepared to participate in the research and complete the enclosed questionnaire. In return for your participation, you will receive a report of the research findings. Our plan is to provide you with the report within the next 6 months. We believe that the report will provide useful information that will enable you to benchmark your performance measurement system with your industry and all responding companies.

We undertake to ensure the confidentiality of all information received. The names of individual respondents and their companies will not be released under any circumstances. If you feel you have been incorrectly identified because you do not have sufficient knowledge relating to the content of the questionnaire we would be grateful if you could pass the documentation to the appropriate colleague within your company. It would be most helpful if you could return the completed questionnaire by 17th February.

Finally, brief information is provided about ourselves to indicate our ability to produce a quality report. Colin is the author of Europe's best selling management accounting textbook. He has also acted as adviser on cost management to one of the UK's leading firms of management consultants and is the co-author of a recent report titled 'Cost systems design in UK companies' published by CIMA. Majdy is a university lecturer and the content of the survey forms part of the PhD that he is currently undertaking. The success of his PhD will be dependent on a sufficient questionnaire response rate.

We hope you will agree to participate. Thank you for your co-operation.

Yours sincerely



Professor Colin Drury ACMA,BA, MBA
E-mail: j.c.drury@hud.ac.uk
Tel. 01484 472299



Mr. Majdy Zuriekat BA, MBA, Ph.D Candidate
E-mail: m.zuriekat@hud.ac.uk
Tel. 01484 473804

B-1

Appendix C: Questionnaire first reminder letter

Date:

Dear

On 27th of January, we sent you a letter requesting your participation in a research project to study performance measurement systems, and the factors that influence their effective usage in UK manufacturing companies. About three weeks ago, we also sent you a reminder letter.

We realise that your busy schedule may have delayed your response to completing the questionnaire that was enclosed with the letter. However, we are writing to you again because of the significance of your participation to the successful completion of this study. Your response would also be very much appreciated since Mr. Zuriekat's PhD dissertation is dependent upon a satisfactory response rate.

As mentioned in our earlier letter, we assure you that any information provided by you will be treated with utmost confidence, as only aggregate results will be reported. There will be no linking of the individual responses, or the firm's name to the published results, and we undertake to ensure the confidentiality of all information received.

Your contribution to the success of this study and the completion of the PhD dissertation is greatly appreciated. We look forward to receiving your completed questionnaire, preferably by 7th March if possible. If by some chance you did not receive the questionnaire, or misplaced it, please call either of us and we will send you another one. Alternatively, you can obtain a printed copy from the following website:

<http://www.hud.ac.uk/schools/hubs/question/questionnaire.doc>

The completed questionnaire can either be mailed to us or downloaded and returned as an E-mail attachment.

Yours sincerely

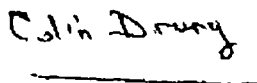

Professor Colin Drury ACMA, BA, MBA
E-mail: j.c.drury@hud.ac.uk
Tel. 01484 472299



Mr. Majdy Zuriekat BA, MBA, Ph.D Candidate
E-mail: m.zuriekat@hud.ac.uk
Tel. 01484 473804

C-1



University of HUDDERSFIELD

Appendix D: Questionnaire second reminder letter

Date:

Dear

On 27th of January, we sent you a letter requesting your participation in a research project to study performance measurement systems, and the factors that influence their effective usage in UK manufacturing companies. We realise that your busy schedule may have delayed your response to completing the questionnaire that was enclosed with the letter. However, we are writing to you again because of the importance of your participation to the successful completion of this study. Your response would also be very much appreciated since Mr. Zuriekat's PhD dissertation is dependent upon a satisfactory response rate.

As mentioned in our earlier letter, we assure you that any information provided by you will be treated with utmost confidence, as only aggregate results will be reported. There will be no linking of the individual responses, or the firm's name to the published results, and we undertake to ensure the confidentiality of all information received.

Your contribution to the success of this study and the completion of the PhD dissertation is greatly appreciated. We look forward to receiving your completed questionnaire, preferably by 7th April if possible. If by some chance you did not receive the questionnaire, or misplaced it, please call either of us and we will send you another one. Alternatively, you can obtain a printed copy from the following website: <http://www.hud.ac.uk/schools/hubs/question/questionnaire.doc>

The completed questionnaire can either be mailed to us or downloaded and returned to Mr. Zuriekat as an E-mail attachment. In the event of you not being prepared to complete the full questionnaire it would be most helpful if you could spend about one minute providing the information below which will assist us in testing whether non-respondents are significantly different in terms of size and industry. If you choose this latter option could you either please return this letter or E-mail the information to Mr. Zuriekat.

1. Please specify the approximate number of employees (full-time equivalents) currently employed in your business unit	-----employees
2. Please specify the approximate annual sales turnover for your business unit for the last financial year	£-----million
3. In what type of business/industry is your business unit engaged? (please be specific: e.g. steel manufacturing, textiles, food processing)	-----

Yours sincerely

Professor Colin Drury ACMA, BA, MBA
E-mail: j.c.drury@hud.ac.uk
Tel. 01484 472299

Mr. Majdy Zuriekat BA, MBA, Ph.D Candidate
E-mail: m.zurickat@hud.ac.uk
Tel. 01484 473804

D-1

